

OPERATOR'S MANUAL

TC5040

TC5050

TC5060

TC5070

TC5080

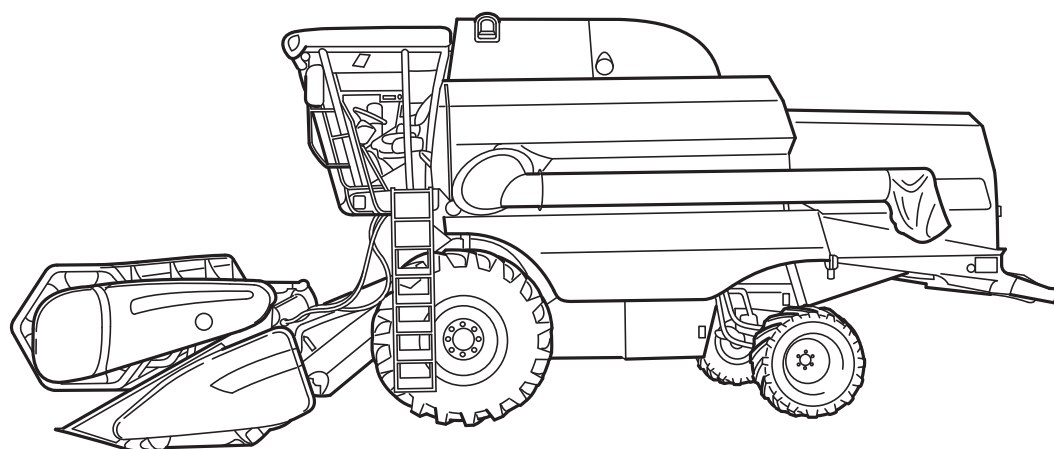

Print No. 87640842

1st edition
English 09/07

from serial no. 9442





GENERAL

This manual has been prepared to assist you in the correct procedure for running in, driving, operating, adjusting and maintaining your new machine.

This machine has been designed and built to give maximum performance, economy and ease of operation under a wide variety of crops and conditions.

Prior to delivery, your machine was carefully inspected both at the factory and by your dealer to ensure that it reaches you in optimum condition. To maintain this condition and ensure trouble-free operation it is important that routine services, as specified in this manual, are carried out at the recommended intervals.

Before attempting to drive or operate your machine, read this manual carefully (especially the chapter covering the Safety Precautions) and keep it in a convenient place for future reference.

"Left" and "right" used throughout this manual are determined from the rear, facing in the direction of travel of the machine during operation.

If at any time you require advice concerning your machine, do not hesitate to contact your authorised dealer. He has factory-trained personnel, genuine service parts and the necessary equipment to carry out your service requirements.

IMPORTANT:

This machine has been designed and built according to the European Directive 98/37/EC. Always use genuine New Holland Service parts or parts matching at least the same quality, reliability and functionality as the equivalent original Service Parts when servicing and repairing your machine and do not modify your machine without a written permission of the manufacturer. Failure to do so will void the responsibility of the manufacturer.

An EC Declaration of Conformity is separately delivered with your machine. Store this EC Declaration into the storage space for your Operator's Manual (refer to section 2 – Controls, Instruments and Operation).

The maximum road speed of your machine is limited. Do not try to change it.

Check local road legislation before driving the machine on public roads.

When operating interchangeable New Holland built equipment, ensure the equipment is CE approved.

As this publication is distributed throughout our international network, the equipment illustrated, either as standard or as an accessory, may vary according to the country in which the equipment is to be used. Low cost configurations, as chosen by the customer, may deviate from the specifications given.

Several figures in this manual show the safety guarding or the additional guards, legally required by certain countries, open or removed to illustrate better a particular feature or adjustment. The machine must not be used in this condition. For your own safety, ensure that all guards are closed or replaced before operating the machine.

OWNER ASSISTANCE

We at New Holland and your New Holland dealer want you to be completely satisfied with your investment. Normally your dealer's Service Department will handle any problems with your equipment. Sometimes, however, misunderstanding can occur. If your problem has not been handled to your satisfaction, we suggest contacting the owner or General Manager of the dealership, explaining the problem, and requesting assistance. When additional assistance is needed, your dealer has direct access to our branch office.

COMPANY POLICY

Company policy, which is one of continuous improvement, reserves the right to make changes in design and specification at any time without notice and without obligation to modify units previously built.

All data given in this book is subject to production variations.

Operating and service messages displayed on the electronic operating panel (monitor), may vary from what is shown in the Operator's Manual. Should this occur adhere to the latest instruction on the electronic operating panel (monitor).

Dimensions and weights are approximate only and the illustrations do not necessarily show the machine in standard condition. For exact information about any particular machine please consult your Dealer.

ACCESSORIES AND OPTIONS

Your machine has been designed to operate in a wide variety of crops and conditions. Nevertheless additional equipment may, in certain cases, be required to improve the machine performance. A list of this additional equipment is given in the "Accessories" section in this manual.

PARTS AND ACCESSORIES

Genuine New Holland parts and accessories have been specifically designed for New Holland machines.

We would like to point out that "nongenuine" parts and accessories have not been examined and released by New Holland. The installation and/or use of such products could have negative effects upon the design characteristics of your machine and thereby affect its safety. New Holland is not liable for any damage caused by the use of "nongenuine" parts and accessories.

Rely on your authorised dealer to supply you with genuine New Holland parts only. These parts are covered by our warranty and will give you the best performance.

When ordering service parts, always quote the model and serial number, as well as the year of manufacture printed on the manufacturer's identification plate (refer to the section "General Information and Safety" in this manual).

LUBRICANTS

Your dealer sells a selection of specially formulated lubricants based on own engineering specifications.

Recommended lubricants for your machine are listed on the inside back cover of this manual.

WARRANTY

Your machine is warranted according to legal rights in your country and the contractual agreement with the selling dealer. No warranty shall, however, apply if the machine has not been used, adjusted and maintained according to the instructions given in this Operator's Manual.

It is prohibited to carry out any modifications to the machine unless specifically authorised, in writing, by a New Holland representative.

CLEANING YOUR MACHINE

Your machine is a state-of-the-art machine with sophisticated, electronic controls. Even though every precaution has been taken to safeguard electronic components and connections, the pressure generated by some pressure washers is such that complete protection against water ingress cannot be guaranteed.

When using a high pressure washer, do not stand too close to the machine and avoid directing the jet at electronic components, electrical connections, breathers, seals, filler caps, etc.

IMPORTANT ENVIRONMENTAL CONSIDERATIONS

Soil, air and water are vital factors of agriculture and of life in general. Where legislation does not yet rule the treatment of some of the substances, which are required by advanced technology, common sense should govern the use and the disposal of the products of a chemical and a petrochemical nature.

The following are recommendations, which may be of assistance:

Become acquainted with and respect the relative legislation applicable in your country.

Where no legislation exists, obtain information from suppliers of oils, fuels, antifreeze, cleaning agents, etc. for their effect on man and nature and for safe ways of storage, usage and disposal. Agricultural consultants will, in many cases, be able to help you as well.

HELPFUL HINTS

Avoid filling fuel tanks using jerrycans or inappropriate pressurized fuel delivery systems which may cause considerable spillage.

In general, avoid skin contact with all oils, acids, solvents, etc. Most of them contain substances which can be harmful to your health.

Use biodegradable oils for chain lubrication where oils cannot be recuperated. In many countries rapeseed oils or other agro-based lubricants have become available.

Modern oils contain additives. Do not burn contaminated fuels and/or waste oils in ordinary heating systems.

Avoid spillage when draining off used engine coolant mixtures, engine, gearbox and hydraulic oils, brake fluids, etc. Do not mix drained brake fluids, fuels or coolant mixtures with lubricants. Store them safely until they can be disposed of in a proper way to comply with local legislation and available resources. They should not be allowed to get into the soil but should be collected and disposed of safely.

Do not open the air-conditioning system yourself; it contains gases, which should not be released into the air. Your dealer has a special extractor for this purpose and will have to do the recharging of the system anyway.

Repair any leaks or defects in the engine cooling or the hydraulic system immediately.

Do not increase the pressure in a pressurized circuit as this may lead to bursting of the components.

Protect hoses during welding as penetrating weld splatter may burn a hole or weaken them, causing the loss of oils, coolant, etc.

Battery recycling

Batteries and electric accumulators contain various components which can damage the environment if they are not properly recycled after usage. New Holland strongly recommends that you return all used batteries (starting batteries and small "dry" batteries which may be used in electric or electronic systems) to your New Holland dealer who will ensure proper disposal or recycling. In certain countries this is a legal requirement.

SECTION QUICK REFERENCE

- 1 – General Information and Safety**
- 2 – Controls, Instruments and Operation**
- 3 – Field and Site Operation**
- 4 – Lubrication and Maintenance**
- 5 – Fault Finding**
- 6 – Vehicle Storage**
- 7 – Accessories**
- 8 – Specification**
- 9 – 1st 50 Hour Service Sheets**
- 10 – Index**

TABLE OF CONTENTS

SECTION 1 – GENERAL INFORMATION AND SAFETY

Intended use	1-1
Product identification	1-1
Base unit	1-1
Engine	1-2
High-Capacity Grain Header	1-2
Maize Header	1-2
Record below the serial numbers of your machine for quick reference	1-2
Safety precautions	1-3
Precautionary statements	1-3
Personal safety	1-3
Machine safety	1-3
General recommendations	1-4
Starting up the combine	1-5
Travelling on public roads	1-6
Operating the combine	1-7
Operating the attachments	1-8
Stopping the combine	1-8
Maintenance	1-9
Engine	1-11
Diesel fuel	1-12
Biodiesel fuel	1-12
Battery warning	1-13
Illustrations	1-13
Legal obligations	1-14
Safety requirements for fluid power systems and components – hydraulics (European Standard EN 982)	1-14
Airborne noise emission	1-15
Electromagnetic compatibility (EMC)	1-15
Vibration level information	1-15
safety decals	1-16
Protective devices	1-25
Cylinder safety latch on straw elevator	1-25
Header additional safety latch	1-25
Straw elevator additional support	1-25
Wheel chock	1-26
Safety guard for straw elevator	1-26
Signal plates	1-27
Reverse driving buzzer	1-27
Safety guards	1-28
Straw chopper spreader chute	1-28
Fire extinguisher (if installed)	1-29
Access to machine components	1-30
Right-hand side covers	1-34
Left-hand side covers	1-34
Attaching a trailer	1-36
Towing the combine	1-36
Lifting the combine	1-37
Tie downs for shipping	1-38
Adjustment of the dimmed lights	1-39
Attachment compatibility	1-40

SECTION 2 – CONTROLS, INSTRUMENTS AND OPERATION

Cab and controls	2-1
Cab door	2-1
Emergency exit	2-1
Clutch pedal (TC5040 – TC5060)	2-1
Operator's seat and surroundings	2-2
Steering column and control pedals	2-5
Right-hand module	2-6
Alarm control module	2-14
Multi-function handle	2-15
Cab roof controls	2-17
Lighting and mirrors	2-19
Right-hand side components	2-22
Left-hand side components	2-23
Other components	2-25
Performance monitor (if installed)	2-26
Display with keyboard functions	2-28
Monitor settings	2-29
Full header width	2-30
Ground speed constant adjustment	2-31
Automatic ground speed calibration	2-32
Straw chopper availability	2-33
Metric / Imperial setting	2-34
Area counter	2-35
Area indication	2-35
Partial area	2-36
Stored area	2-36
Total area	2-37
Storing partial area	2-38
Software version	2-39
Audible alarm	2-40
Machine error messages	2-41
Engine error messages	2-42
Automatic shut-off	2-44

SECTION 3 – FIELD AND SITE OPERATION

Before driving the combine	3-1
Starting the engine	3-2
Daily start-up procedure	3-2
Stopping the engine	3-3
Driving the combine	3-3
Mechanical drive units	3-3
Hydrostatic drive units	3-3
Combine functions	3-4
Feeding	3-5
Threshing	3-6
Separation	3-6
Cleaning	3-6
Grain storage and unloading	3-9
To change from grain to maize, the following modifications need to be done	3-14
Combine performance check	3-15
Kill stall	3-15
Performance indicators	3-15

Grain tank sample	3-15
Grain pan/upper sieve distribution	3-16
Return sample	3-16
Losses	3-16
How to obtain an idea on loss level	3-18
Header	3-19
Attaching the header to the combine	3-19
In case of quick-coupling	3-20
Detaching the header from the combine	3-21
Header levelling	3-22
Header and straw elevator reversing system	3-23
Manual clearing of the header and straw elevator blockage	3-24
Stubble height indicator (if applicable)	3-24
Header compensation gauge	3-24
Header height control	3-25
Operation modes	3-26
Transport operation	3-26
Compensation operation	3-27
Autofloat™ or Controlfloat™ operation [if sensors are fitted]	3-28
Stubble height operation	3-29
Header height control calibration	3-31
Purpose	3-31
Ground level calibration	3-32
Maximum cylinder pressure calibration	3-33
Ground level calibration through the Autofloat™ sensors	3-34
Auto-diagnostics	3-35
Straw elevator	3-36
Straw elevator adjustment	3-36
Adjustment for harvesting maize (with or without lateral flotation)	3-37
Straw elevator	3-38
Installation	3-41
Drum concave	3-43
Removal	3-43
Stone trap	3-49
Anti-dust plate	3-50
Access to the grain pan	3-50
Drum and concave	3-51
Adjustment values	3-51
Fundamentals of adjustment	3-51
Drum speed	3-51
Access to the drum and to the concave	3-52
Access from the front	3-52
Access from the left-hand side	3-52
Access from the right-hand side	3-53
Drum blockage	3-53
Concave clearance	3-54
Basic settings	3-54
Concave clearance mechanical adjustment	3-55
Concave position for harvesting maize	3-55
De-awning plates	3-56
De-awning slats (accessory)	3-57
Drum and concave type use	3-57
Beater	3-58
Rotary separator [if installed]	3-59

Rotary separator speed	3-59
Speed adjustment	3-59
Rotary separator wear plates	3-59
Straw-retaining curtain	3-60
To change the position of the straw retarding curtain, proceed as follows	3-60
Straw walkers	3-61
Sieve types (available)	3-62
Lower sieve	3-63
Sieve opening adjustment	3-63
Positioning, removal, installation	3-63
Upper sieve	3-64
Sieve opening adjustment	3-64
Positioning, removal, installation	3-65
Self-levelling cleaning system (if installed)	3-66
Grain pan dividers	3-66
Cleaning fan	3-67
Fan speed adjustment	3-67
Returns system	3-69
Cleaning access	3-69
Returns	3-70
How to limit the returns	3-70
Grain storage/unloading	3-71
Grain tank filling system	3-71
Grain tank cover	3-72
Grain sample	3-72
Grain tank unloading auger	3-73
Unloading tube	3-73
Grain tank level sensor (if installed)	3-74
Straw handling	3-75
Straw chopper (if installed)	3-75
Transport position	3-75
Swath-forming position	3-75
Swathing rake	3-76
Chopping position	3-77
Manual adjustable deflector plates (if installed)	3-78
Remote adjustable deflector plates (if installed)	3-78
Straw chopper operation	3-79
Straw chopper clutch	3-79
Access to the straw chopper rotor	3-80
Straw chopper rotor knives	3-80
Counter knives	3-81
Chopping maize	3-82
Chaff spreader (if installed)	3-84
Disengaging and removing the chaff spreader	3-87
To install, proceed as follows	3-90

SECTION 4 – LUBRICATION AND MAINTENANCE

General	4-1
Grease fittings and intervals	4-1
Grease specification	4-1
10 hours interval (daily) – left-hand side	4-2
10 hours interval (daily) – right-hand side	4-3
50 hours interval – left-hand side	4-5
50 hours interval – right-hand side	4-8
100 hours interval – left-hand side	4-11
100 hours interval – right-hand side	4-12
Engine	4-13
Oil level	4-13
Engine sump and filter capacity (total)	4-14
Oil and filter change	4-14
Oil specification	4-15
Engine cooling system	4-16
Coolant level	4-16
Coolant change	4-16
Coolant system capacity	4-18
Coolant specification	4-18
Fuel tank drain plug	4-19
Fuel prefilter / water separator	4-19
Fuel filter	4-20
Bleeding the fuel system (TC5040 - TC5050 - TC5060)	4-21
Bleeding the fuel system (TC5070 - TC5080)	4-21
Fuel specification	4-22
Fuel storage	4-22
Rotary dust screen and cooling system	4-23
Air intake system	4-24
Hydraulic and hydrostatic system	4-26
Oil reservoir	4-26
Oil level	4-26
Oil and filter change	4-27
Oil capacity	4-29
Hydraulic oil specifications	4-29
Accumulator	4-29
Hydraulic remote control valves	4-30
Hydrostatic system	4-30
Hydrostatic control cable adjustment	4-30
Traction gearbox	4-31
Oil level	4-31
Oil change	4-31
Oil capacity	4-31
Oil specifications	4-31
Oil level	4-32
Oil change	4-32
Oil capacity	4-32
Oil specification	4-32
Final drive gearboxes	4-33
Oil level	4-33
Oil change	4-33
Oil capacity	4-33
Oil specifications	4-33

Chains, threaded rods and pivot points	4-34
Chains	4-34
Threaded rods	4-34
Pivot points	4-34
Brake system	4-35
Brake fluid level	4-35
Fluid change	4-35
Capacity	4-36
Fluid specification	4-36
Clutch fluid level (TC5040 - TC5050)	4-36
Fluid specification	4-36
Lubrication schedule	4-37
Drive chain and belts (left-hand side)	4-38
Header drive belt	4-39
Straw elevator and header engaging drive belt	4-39
Unloading system engaging belt	4-41
Ground speed vari-drive belts	4-42
Belt tension adjustment	4-42
Traction variator adjustment	4-42
Variator support position	4-43
Hydrostatic pump drive belt	4-44
Cleaning shoe drive belt	4-44
Main engaging drive belt	4-45
Grain cross auger and elevator drive belt	4-46
Grain returns cross auger and elevator drive chain	4-46
Straw chopper front drive belt (if installed)	4-46
Straw chopper rear drive belt (if installed)	4-46
Chaff spreader drive belt (if installed)	4-47
Chaff spreader discs drive belt (if installed)	4-47
Drive chain and belts (right-hand side)	4-48
Drum variator belt	4-49
Check and adjustment of variator	4-49
Grain tank bottom auger drive chain	4-50
Returns top auger drive chain	4-51
Grain tank filling auger drive chain	4-51
Cleaning fan variator drive belt	4-51
Fan variator adjustment	4-52
Straw walker drive belt	4-52
Rotary separator drive belt (if installed)	4-53
Drive belts - engine compartment	4-54
Rotary dust screen drive belt	4-55
Alternator, water pump and air conditioning compressor drive belt (TC5070 - TC5080)	4-55
Rotary dust screen intermediate shaft drive belt	4-55
Engine cooling fan drive belt	4-56
Hydraulic pump drive belt (TC5070 - TC5080)	4-56
Alternator and water pump drive belt (TC5040 - TC5050 - TC5060)	4-56
Air conditioning compressor drive belt (If installed) (TC5040 - TC5050 - TC5060)	4-56
Straw elevator	4-57
Chain tension	4-57
Straw elevator slip clutch	4-57
Elevator chains	4-58
Grain elevator	4-58

Returns elevator	4-59
Elevator slip clutch	4-59
Self-levelling system calibration	4-60
self-levelling system blockage	4-61
Brakes	4-62
Foot brakes	4-63
Foot brake “bedding-in” procedure	4-63
Parking brake	4-64
Traction clutch	4-66
Steering axle	4-67
Toe-in adjustment	4-67
Fixed steering axle	4-68
Adjustment	4-68
Steering wheel stops	4-68
Steering ball joints	4-69
Adjustable steering axle (if installed)	4-70
Adjustment	4-70
Steering wheel stops	4-71
Steering axle ball joint	4-71
Electrical system	4-72
Fuses and relays	4-72
Batteries	4-77
Important tips	4-78
Battery charge warning light	4-79
Alternator	4-79
Cab/climate control	4-80
Cab air filter	4-80
A/C system (if installed)	4-81
Condenser	4-81
Evaporator	4-82
Filter-drier	4-82
Air compressor (if installed)	4-83
Air reservoir specification	4-84
Maintenance schedule	4-85

SECTION 5 – FAULT FINDING

Header height control – Error messages	5-16
Machine – Error messages	5-18
Engine – Error messages	5-19

SECTION 6 – VEHICLE STORAGE

End-of-season service	6-1
Ordering parts and/or accessories	6-3
Pre-season service	6-4

SECTION 7 – ACCESSORIES

Feeding	7-1
Grain header illumination kit	7-1
Quick release coupler	7-1
Straw elevator	7-2
Anti-wrap shields	7-2
Rice kit for fixed straw elevator	7-2
Rice kit for lateral float straw elevator	7-2
Third header lift cylinder	7-2
Threshing and separation	7-3
Straw walker vertical cover plates	7-3
De-awning slats	7-3
De-awning plates	7-4
Beater pins	7-4
Cereal threshing rebuild kit	7-5
Rice threshing rebuild kit	7-5
Maize threshing rebuild kit	7-5
Maize special dry conditions	7-5
Cleaning system	7-6
Upper sieve HC 1-5/8" (FS+SL)	7-6
Round hole sieves	7-6
Graepel sieve extension (fixed cleaning shoe)	7-6
Graepel sieve extension (self-levelling cleaning shoe)	7-6
Cleaning fan bottom shield	7-7
Grass seed equipment	7-7
Extended dividers (only for units with fixed upper sieve)	7-7
Clean grain, grain tank and unloading	7-8
Perforated covers under augers and elevators	7-8
Grain tank level sensor	7-8
Grain elevator high speed kit	7-8
Straw handling	7-9
Straw walker protection	7-9
Straw chopper with manually adjustable deflectors	7-9
Remote adjustable spreader plates rebuild kit	7-9
Straw chopper slow-down kit	7-10
Straw chopper guards for maize	7-10
Chaff spreader (TC5060 - TC5070 - TC5080)	7-11
Straw spreader	7-11
Swathing rake	7-11
Traction and tyres	7-12
Ladder extension	7-12
Hinging ladder extension (TC5080)	7-12
Steering platform extension	7-12
Engine	7-13
Air compressor kit (TC5070 - TC5080)	7-13
Air gun and hose (TC5070 - TC5080)	7-13
Rotary dust screen brush	7-14
Grid heater	7-14
Cab	7-15
Sun canopy	7-15
Additional mirrors	7-15
Screen washer kit	7-15
Heating	7-15

Electrical and electronic equipment	7-16
Revolving flash light	7-16
Adjustable light on grain tank	7-16
Portable operating light and stubble lights	7-17
Performance monitor	7-17
Miscellaneous	7-18
Header trailer hitch	7-18
Wheel counterweights	7-18
Signal plates	7-19
Signal plates for Germany	7-19
Specs Germany	7-19
Fire extinguisher	7-19

SECTION 8 – SPECIFICATIONS

Wheels and tyres	8-1
Wheel nuts torque	8-1
Technical data	8-7
Dimensions	8-16
Grain tank unload tube position	8-17
Dimensions	8-18

SECTION 9 – 1ST 50 HOUR SERVICE SHEETS

Check and adjust, as required (Customer copy)	9-1
Check and adjust, as required (Dealer copy)	9-3

SECTION 10 – INDEX

SECTION 1 – GENERAL INFORMATION AND SAFETY

INTENDED USE

The TC combine harvesters are designed as self propelled units and powered by an onboard diesel engine.

These machines are intended to be used for agricultural purposes on cultivated land to harvest cereal crops, small seed crops, maize, soya beans, etc., by cutting or picking up from a swath, threshing and separating the grain from the straw and temporarily storing it until it is unloaded into vehicles for transport.

PROHIBITED USAGE

No parts or attachments should be fitted to this machine, which have not been released by NEW HOLLAND. They might affect machine operation, safety of the user or other people, stability or wear characteristics of the machine. They may also void the homologation approval obtained for your country.

PRODUCT IDENTIFICATION

The serial number of combine, engine and attachments, can be found in the following locations:

Base unit

On a plate, positioned on the right-hand side of the operator's platform.

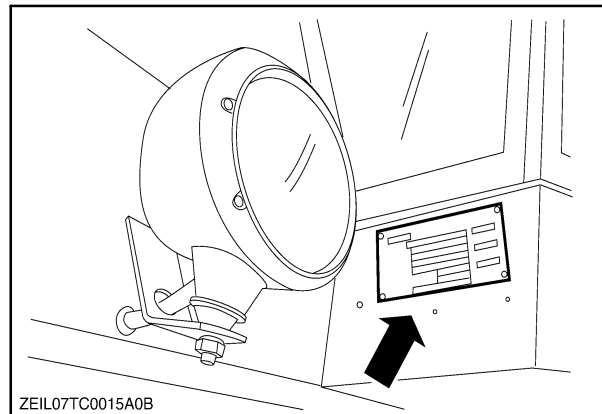

1

Stamped on the right-hand side of the combine above the front axle.

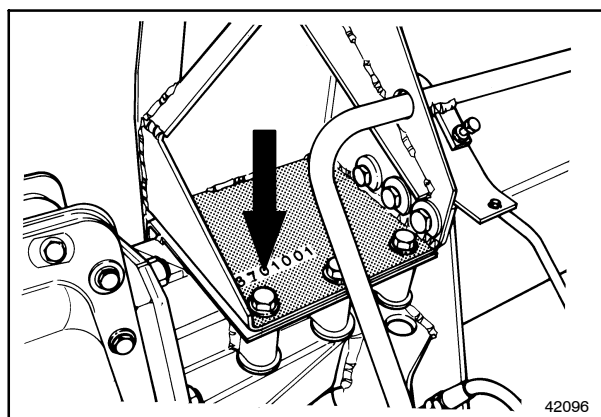

2

Engine

On a plate positioned on the cylinder block.

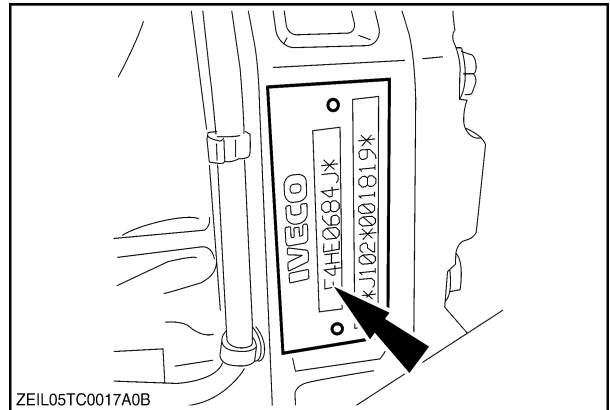

3

■ **High-Capacity Grain Header**

In the right-hand upper corner, and also on a plate.

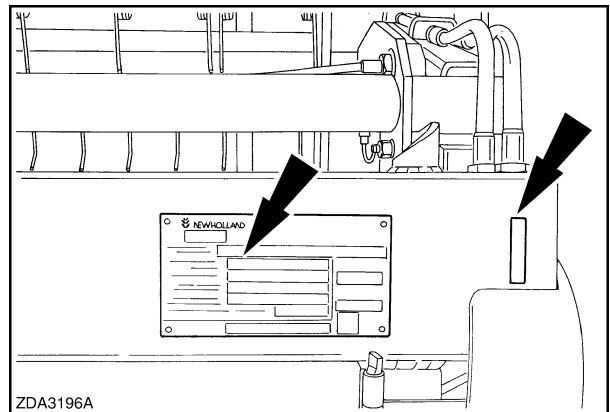

4

Maize Header

On a plate positioned on the left-hand upper corner.

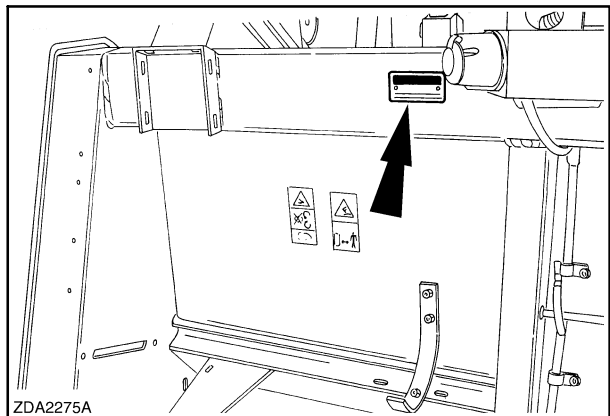

5

Record below the serial numbers of your machine for quick reference:

Combine model.....

Combine serial number.....

Engine serial number.....

Grain header serial number.....

Maize header serial number.....

Date machine first used.....

Dealer's telephone number.....

SAFETY PRECAUTIONS

Farm accidents can be prevented with your help.

No accident prevention programme can be successful without the wholehearted cooperation of the person who is directly responsible for the operation of the equipment.

Farm machinery can create hazards if not used in the proper way.

Further in this Section you will find a list of the most important safety precautions.

CAUTION

This symbol is used throughout this manual whenever your personal safety is involved.

Take time to read and follow the instructions and furthermore, be careful!

Some pictures in this manual may show the safety guarding open or removed to better illustrate a particular feature or adjustment.

Ensure to close or replace all guards before operating the machine.

PRECAUTIONARY STATEMENTS

Personal safety

Throughout this manual and on machine decals, you will find precautionary statements ("CAUTION", "WARNING", and "DANGER") followed by specific instructions. These precautions are intended for the personal safety of you and bystanders. Please take the time to read them.

CAUTION

The word "CAUTION" is used where a safe behavioural practice according to operating and maintenance instructions and common safety practices will protect the operator and bystanders from accident involvement.

WARNING

The word "WARNING" denotes a potential or hidden hazard which could possibly cause serious harm. It is used to warn operators and others to exercise due care and attention to avoid a surprise accident with machinery.

DANGER

The word "DANGER" denotes a forbidden practice in connection with a serious hazard.

FAILURE TO FOLLOW THE "CAUTION", "WARNING", AND "DANGER" INSTRUCTIONS MAY RESULT IN SERIOUS BODILY HARM OR DEATH.

Machine safety

Additional precautionary statement ("IMPORTANT") is followed by specific instructions. This statement is intended for machine safety.

IMPORTANT: *The word "IMPORTANT" is used to inform the reader of something he needs to know to prevent minor machine damage if a certain procedure is not followed.*

GENERAL RECOMMENDATIONS

Most farm machinery accidents can be avoided by the observance of a few simple safety precautions.

1. The machine must only be used by a skilled operator familiar with all the controls and harvesting techniques on cultivated land with slopes up to maximum 26% (15°) uphill and downhill and maximum 36% (19°) sideways [provided good even ground and sufficient tyre adherence conditions exist].
2. Never permit anyone other than the operator to ride on the combine.

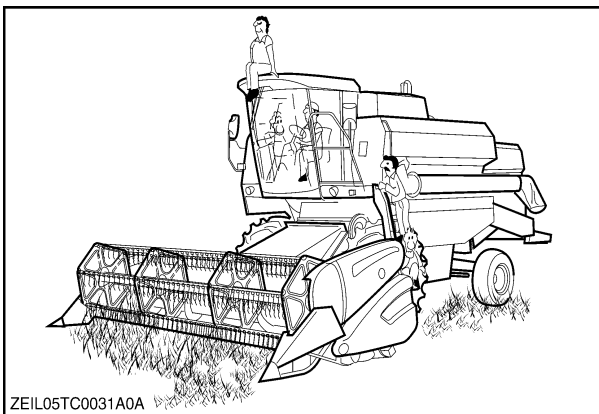

3. Before starting the engine, ensure everyone is clear of the combine.

Warn bystanders by sounding the horn several times.

4. Keep children away from and off the combine at all times.
5. No-one should be standing on the ladders or platforms when the machine is moving.
6. Never brake abruptly to avoid tipping of the machine.

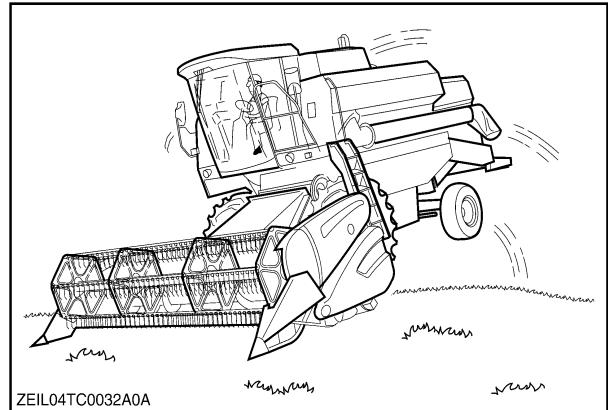

7. Never exceed 20 km/h when driving downhill. If necessary, change into a lower gear before starting the descent.

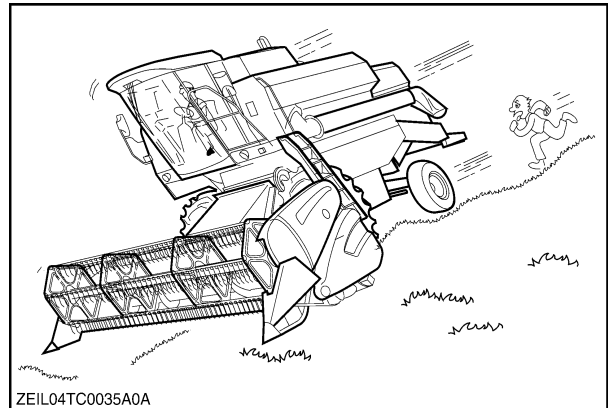

8. Avoid making turns at high speed.
9. Before operating the combine ensure that all safety guards are installed.
10. Never step on places on the machine which are not foreseen with anti-slip strips.
11. Check the wheel nuts torque daily during the first week of operation and thereafter on a weekly basis. Tighten as described in "SECTION 8 - SPECIFICATIONS".

SECTION 1 – GENERAL INFORMATION AND SAFETY

- The life and performance of the tyres depends largely upon maintaining the correct pressure. Keep the tyres inflated to the pressures given in “SECTION 8 – SPECIFICATIONS”.
- Never enter the grain tank while the combine engine is running. Use a wooden clearing club if the grain tank unloading auger becomes clogged. Take utmost care not to be pulled into the grain tank in case unplugging is required.

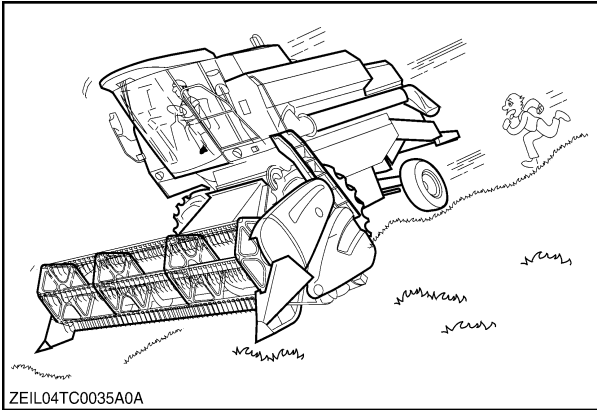

- Never work around the combine in loose clothing that might catch in any of the moving parts.
- Never change or tamper the engine software as this will invalidate the warranty and the homologation of your machine.

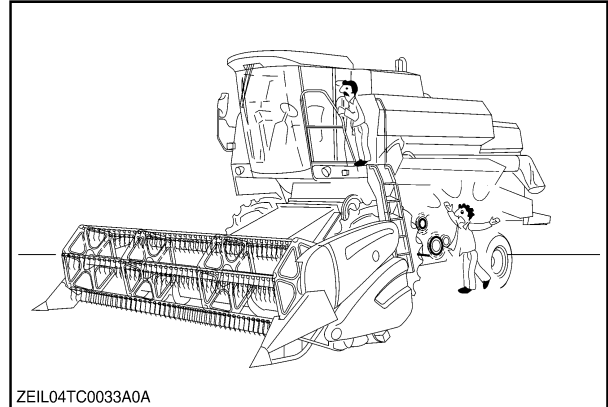

- Keep hands away from moving parts of the combine.
- Keep the fire extinguisher within easy reach of the operator. Ensure to replace it by a similar type of extinguisher or have it checked or refilled after every usage and/or date of expiry.
- Never step on the cab roof.
- Combine dust can cause “farmer’s lung” disease. It may also contain nocive spraying residues. Keep the cab door and window closed during operation. Wear a dust mask when cleaning the air filters or accumulated dust in the combine.

STARTING UP THE COMBINE

- Never attempt to start up or manoeuvre the combine unless you are sitting in the operator’s seat.
- Before starting up the combine (e.g. the first time after a long standstill period), make sure that there are no detached loose part in the attachment, the drive line area and/or on the rotary dust screen.
- Before starting the engine, always make sure that the multifunction handle and the gearshift selector switch are in NEUTRAL position, and the safety-on-the-road tumbler switch is in ROAD position.
- Never run the engine in an enclosed area without ensuring adequate ventilation as exhaust fumes are toxic and, if inhaled, may be fatal.

TRAVELLING ON PUBLIC ROADS

1. Make sure the safety-on-the-road tumbler switch is in ROAD position.
2. Always observe the local regulations. Should the width of the attachment be wider than the permitted road width, contact the local authorities for assistance or licences.
3. Observe traffic regulations, adapt your speed to road and traffic conditions and ensure all lights are working properly.
4. Where required by local traffic regulations, ensure the hazard warning plates are fitted at the front and the rear of the machine.
5. Use the revolving flash lights to indicate the vehicle has abnormal size and is slow-moving.
6. Never drive on public roads with the operating lights and spotlight switched on.
7. Dip the headlights when meeting a vehicle at night. Make sure the lights are adjusted to prevent blinding the driver of an oncoming vehicle.
8. Avoid taking corners at high speed.

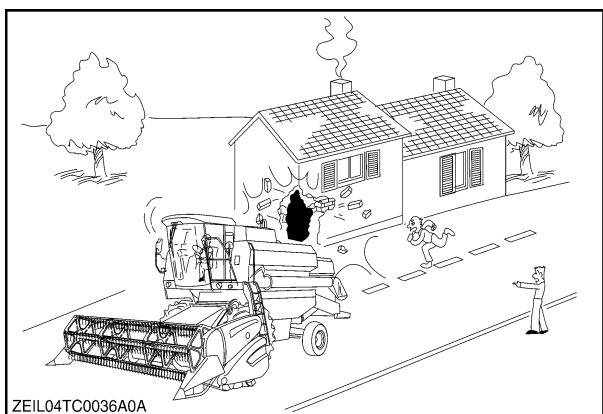

9. Before travelling on the road, link the brake pedals together with the coupling provided. Braking with the pedals uncoupled may cause the machine to swerve or yaw. Also, avoid excessive use of the brakes.

10. Always depress the brake pedal gently to avoid tipping of the machine.

CAUTION

Before driving on the road with a header attached smaller than 4 meter (foldable grain header or flip-up maize header), contact your local dealer for:

- Counterweights
- Additional headlights

11. Never rest your feet on the brake pedals when the machine is in motion.
12. When manoeuvring the machine off the field, always raise the attachment fully to avoid contact with obstructions.
13. The grain tank must be empty when driving on the road. Ensure that the unloading tube is locked in its closed position.
14. When driving on public roads, either with the grain header loaded on a trailer and attached to the rear of the combine, or with the grain header still attached to the combine (provided local legislation allows), the knife should be safeguarded by means of a knife guard, available as an accessory (refer to the Grain Header Operator's Manual).
15. When driving on public roads, either with the grain header loaded on a trailer and attached to the rear of the combine, or with the grain header still attached to the combine (provided local legislation allows), always be aware and conscious of its size.

OPERATING THE COMBINE

1. Before operating the combine ensure that all safety guards are properly fitted and secured.
2. Never attempt to clean, lubricate or carry out any adjustments on the combine while it is in motion or while the engine is running.
3. For safety's sake never leave the operator's platform without first disengaging the combine drive mechanism, lowering the header, stopping the engine, applying the parking brake and removing the ignition key.
4. Never climb on or off the machine when it is in motion as there is a risk of being run over.
5. Use extreme caution when operating close to the edge of a ditch, a canal or a steep bank.
6. Avoid changing direction abruptly, especially when reversing, to avoid dangerous pitching of the machine. Lower the attachment if the machine tends to lift at the rear.
7. Always operate the combine at a safe speed in accordance with the ground conditions. On uneven ground, proceed with the utmost caution to ensure proper stability.
8. When operating on gradients, never drive too fast, especially when turning.

9. Danger of death by electrocution!

Pay special attention to the overhead power lines. Make sure the machine has sufficient clearance to pass in all directions (also with raised or opened machine components). Also think of the radio aerial(s) or any other accessory or parts which may have been added afterwards. A decal in the cab indicates the height of the unloading tube in open position.

Should a contact between the machine and an electric power line occur, then the following precautions must be taken: Stop the machine movement immediately, stop the engine and apply the handbrake.

Check if you can safely leave the cab or your actual position without direct contact with electric wires. If not, stay in your position and call for help. If you can leave your position without touching the lines, jump off the last step or support position to ensure that there is no contact between any part of your body and the ground at any time. Never touch the machine afterwards until power to the lines has been shut off. When people approach the machine, warn them not to touch the machine but to ask the electric power supply company to shut off the power to the lines.

10. Never apply the differential lock when turning. When engaged, the differential lock will prevent the combine from turning.
11. Ensure the engine is shut off and wait until the machine has completely stopped before opening any of the guards.

THERE ARE ROTATING PARTS UNDER THE GUARDS WHICH MAY CONTINUE ROTATING AFTER THE MACHINE HAS BEEN STOPPED.

Look and listen for evidence of rotating parts before opening any of the guards.

OPERATING THE ATTACHMENTS

1. When coupling an attachment to the base unit, never stand between the machine and the attachment.
2. Make sure that no one is standing in front of the machine when detaching an attachment.
3. Before operating the attachment, make sure that there is no one on or near the machine.
4. Never attempt to remove crop or residues from a plugged attachment while the machine is running. Such an imprudence could cost life or limb. In the event of a blockage, always disengage the threshing mechanism, switch off the harvester engine and apply the parking brake before clearing the blockage.

STOPPING THE COMBINE

1. Always lower the attachment to the ground when parking the machine.
2. For safety's sake never leave the operator's platform without first returning the ground speed control lever to neutral, switching off the threshing mechanism, engaging the parking brake and stopping the engine. Furthermore, if leaving the machine unattended, always remove the ignition key and switch off the switch on the battery key.
3. When parking, always try to leave the machine on level ground and apply the parking brake. If the ground is sloping, apply the parking brake and wedge the wheels. In an emergency, when this is not possible, position the machine sideways on in relation to the slope, engage first gear, operate the parking brake. If it is not possible to stop according to the above instructions, observe the following instructions:
 - Machine on a downward slope: gently pull back the hydrostatic control lever, until you can feel the traction effect of the transmission; shut off the engine and apply the parking brake. Get down from the machine and position the chock (if available) or a solid body of suitable size in front of the traction wheels.
 - Machine on an upward slope: put into first gear, push the hydrostatic control lever forward, until you can feel the traction effect of the transmission, switch off the engine and apply the parking brake. Get down from the machine and position the chock (if available) or a solid body of a suitable size behind the traction wheels.

MAINTENANCE

1. Follow the maintenance schedule with regard to the machine servicing intervals. Remember that the machine requires minor attention from time to time. Also remember that the time taken on maintenance will greatly extend the life of the machine.
2. Never attempt to clean, lubricate or carry out any adjustments on the combine while it is in motion or while the engine is running.
3. Keep hands, feet and/or garments away from moving parts. Check that all rotating parts are correctly guarded.
4. Never work under the attachment without first ensuring that the straw elevator hydraulic cylinder safety latch is engaged or that it is securely supported on wooden blocks.
5. Always use suitable jack stands when carrying out maintenance on the traction or the steering axle.
6. Keep the combine, particularly the brakes and steering, maintained in a reliable and satisfactory condition to ensure your safety and compliance with legal requirements. Regularly check the efficiency of the brakes and replace the brake pads before they are totally worn out.
7. Any leakage of hydraulic oil or fuel under pressure may cause severe harm, so always use a shield, goggles and gloves when tracing oil or fuel leaks.

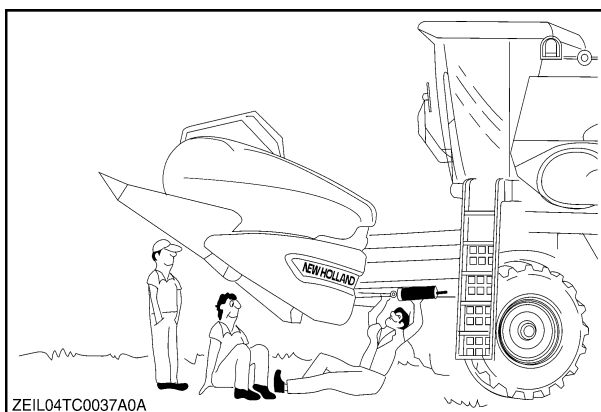

SECTION 1 – GENERAL INFORMATION AND SAFETY

8. Never construct flexible hose assemblies from hoses which have been previously used as part of a hose assembly.
9. Never weld to the piping.
10. When flexible hoses or pipings are damaged, replace them immediately.
11. Always replace worn or frayed belts before they fail.
12. Always disconnect the battery earth lead before carrying out any work on the electrical system.
13. Disconnect the alternator wires and the battery cables before carrying out any electrical welding on the machine. In addition, attach the earth cable of the electric welder as close as possible to the area to be welded.
14. Remove all tools from the machine after carrying out any lubrication, maintenance or repair work. Also, make sure that all components have been securely tightened and all guards properly fitted. Replace or repair damaged guards immediately.
15. Combine wheels are very heavy. Handle with care and ensure, when stored, that they cannot topple over and cause injury.
16. Never work on the tyres unless you have the special tools and the necessary experience. Incorrect fitting could be a serious safety hazard. If in doubt, call in qualified personnel.

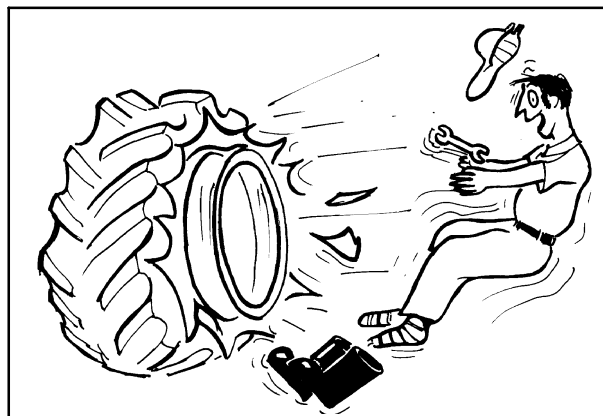

17. Never attempt to service the air conditioning system. You may be severely frost bitten or injured by escaping refrigerant. Special equipment and instruments are required to service the air conditioning system. Contact an authorised dealer for service.
18. Adhere to all recommendations that are mentioned in this manual such as service intervals, torques, lubricants, etc.

ENGINE

1. Keep the engine area clean of dust, chaff and straw to prevent the possibility of fires.

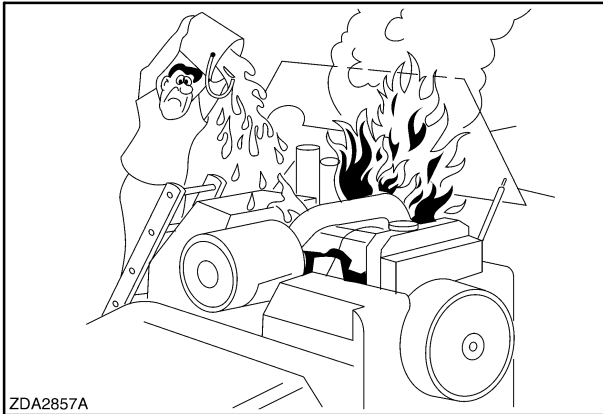

2. Never idle the engine in an enclosed area as harmful exhaust gases may build up.
3. Wear a suitable hearing protective device, such as ear muffs or ear plugs, if you are exposed to noise which you feel is uncomfortable.



4. The cooling system operates under pressure which is controlled by the radiator cap. It is dangerous to remove the cap while the engine is hot.
 - Switch off the engine and wait until it has cooled. Even then use extreme care when removing the cap. Cover the cap with a rag and turn it slowly to the first stop to allow the pressure to escape before removing the cap completely. Stand clear of the radiator opening as hot coolant may splash out.
 - Never add cold water to a hot radiator.

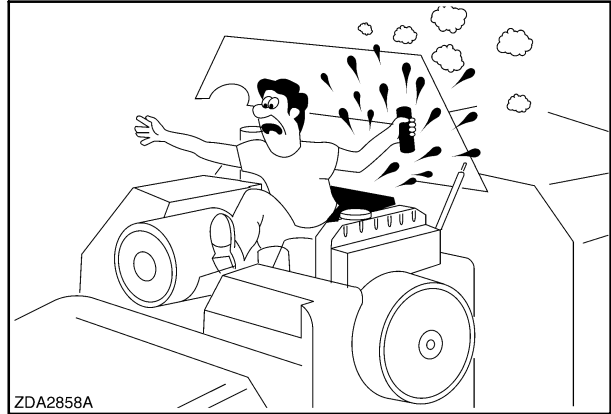

Failure to follow these instructions may result in serious personal injury from hot coolant or steam blowout and/or damage to the cooling system or engine.

5. Antifreeze contains monoethylene glycol and other chemicals which are toxic if taken internally and can be absorbed in toxic amounts through repeated or prolonged skin contact. Follow these precautions when working with antifreeze:
 - Never take antifreeze internally. If antifreeze is swallowed accidentally, obtain medical attention immediately.
 - Keep antifreeze in sealed containers out of reach of children, livestock or pets.
6. The fuel oil in the injection system is under high pressure and can penetrate the skin. Unqualified persons should not remove or attempt to adjust any part of the fuel injection system. Failure to follow these instructions may result in serious harm.

If fuel is injected through the skin, medical assistance should be obtained.
7. Be very careful to avoid contact with hot engine oil. If the engine oil is extremely hot, allow the oil to cool to a moderately warm temperature for safe removal.
8. Never handle a hot oil filter with bare hands.
9. Continuous and prolonged contact with used engine oil may cause skin cancer. Protect your skin by wearing heavy plastic gloves. If oil gets onto the skin, wash promptly with soap and water.

DIESEL FUEL

1. Under no circumstances should gasoline, alcohol or blended fuels be added to diesel fuel. These combinations can create an increased fire or explosive hazard. In a closed container, such as a fuel tank, such blends are more explosive than pure gasoline. **Never use these blends.**
2. Never remove the fuel tank cap or refuel with the engine running or hot. Refuel the combine fuel tank only when the engine has been turned off. Never smoke or use a naked flame when refueling or when standing near fuel tanks.
3. Maintain control of the fuel filler pipe nozzle when filling the tank.
4. Never fill the fuel tank to capacity. Allow room for some expansion.
5. Wipe up spilled fuel immediately.
6. Always tighten the fuel tank cap securely.
7. If the original fuel tank cap is lost, replace it with an approved cap. A non approved, proprietary cap may not be safe.

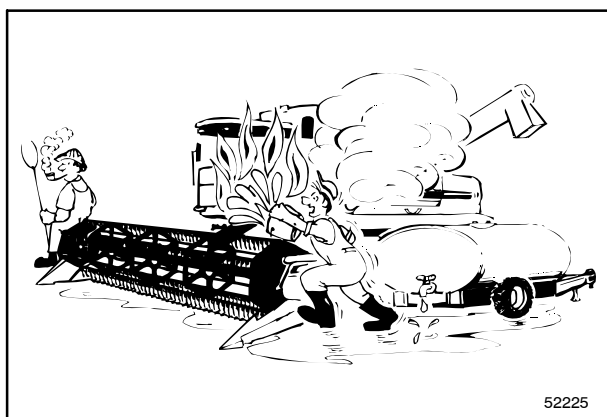

8. Keep fuel equipment clean and properly maintained.
9. Never drive equipment near open fires.
10. Never use fuel for cleaning purposes.
11. Fuel quality must meet EN590.

BIODIESEL FUEL

The use of biodiesel blends meeting Specification Standards EN14214 is approved for your engine up to B20 (20% blend ratio) for TC5070 and TC5080, up to B100 for TC5040, TC5050 and TC5060. It is highly recommended that you use biodiesel fuel from accredited suppliers to maintain the quality and consistency of the fuel.

Biodiesel does not have a long term stability and should not be left in engines or stored for more than four months. Prior to storing your machine for more than 4 months, the engine should be flushed by running for a minimum of 30 minutes with conventional diesel fuel.

Biodiesel fuel has a higher cloud point than conventional diesel fuels and is not recommended for use in winter months. Consult your fuel dealer for winter fuel requirements for your area.

Biodiesel fuel attracts moisture and may contain a higher water content than conventional diesel fuel. It may be necessary to drain the fuel filter water trap more frequently.

BATTERY WARNING

—  **CAUTION**  —

The battery contains a sulphuric acid electrolyte which may cause severe burns and produce explosive gases. Avoid contact with the skin, eyes or clothing. Never take internally.

The essential precautions listed must be observed:

- *Never use a naked flame to check the electrolyte level. Keep sparks, flames and lighted tobacco away.*
- *Never produce sparks with cable clamps when charging the battery or starting the engine with a slave battery.*
- *Wear eye protection when working near batteries.*
- *Provide ventilation when charging or using in an enclosed space.*
- *Ensure the vent plugs are correctly installed and tight.*

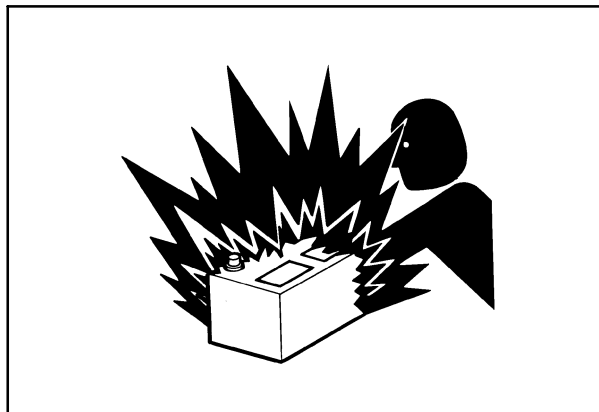

If the electrolyte comes into contact with the skin, eyes or is taken internally, treat as follows:

- | | |
|-----------|--|
| Skin: | Flush with cold water. |
| Eyes: | Flush with cold water for 10 minutes and get prompt medical attention. |
| Internal: | Call a doctor immediately. |

ILLUSTRATIONS

NOTE: *Some of the illustrations in this Manual have been obtained by photographing prototypes. Standard production machines may differ in some details.*

—  **CAUTION**  —

In some of the illustrations in this Manual the guards or covers have been removed for clarity. Never operate the machine with these protective guards or covers removed.

LEGAL OBLIGATIONS

Your machine may be equipped with special guarding or other devices in compliance with local legislation. Some of these require active action by the operator.

Therefore, check local legislation on the usage of this machine.

SAFETY REQUIREMENTS FOR FLUID POWER SYSTEMS AND COMPONENTS – HYDRAULICS (EUROPEAN STANDARD EN 982)

Flexible hose assemblies may not be constructed from hoses which have been previously used as part of a hose assembly.

Never weld hydraulic piping.

When flexible hoses or piping are damaged, replace them immediately.

It is forbidden to modify a hydraulic accumulator by machining, welding or any other means.

Before removing hydraulic accumulators for servicing, the liquid pressure in the accumulator must be reduced to zero.

Pressure check on hydraulic accumulators shall be carried out by method recommended by the accumulator manufacturer.

Care must be taken not to exceed the maximum allowable pressure of the accumulator. After any check of adjustment there must be no leakage of gas.

AIRBORNE NOISE EMISSION

In line with the European directive (2003/10/EC) and national legislation, the noise levels at the operator's ear are measured in dBa, according to the ISO 5131 standard.

The noise is measured with the engine and all mechanisms engaged and running at normal operating speed for the specified use of the product and without crop flow through the machine. These are maximum values which in normal operating conditions will never be exceeded.

It should be noted that the noise level may exceed 85 dBa if the machine is operating with the doors open.

In this case, the use of ear protection equipment is compulsory.

Machine model	Engine model	Noise level (dBa) Cab doors closed
TC5040	New Holland (*)	82.5
TC5050	New Holland (*)	82.5
TC5060	New Holland (*)	82.5
TC5070	New Holland (*)	82.5
TC5080	New Holland (*)	82.5

(*) developed by CNH engine corporation

ELECTROMAGNETIC COMPATIBILITY (EMC)

This product complies with the EEC directive 2004/108/EC and its amendments on Electromagnetic Interferences on electronic equipment if it is used in conjunction with equipment which bears the CE mark.

New Holland will take no liability for any problem arising as a result of its product working in an environment of other equipment which does not comply with the EEC directive.

Disturbances remain possible if added non New Holland equipment does not meet the standards. As these interferences may result in serious malfunction of the machine and/or create unsafe situations the following instructions must be observed:

Each element of non New Holland equipment added to this New Holland product must bear a CE mark.

The maximum power of emission equipment (radio, telephones, etc.) must not exceed the limits imposed by the national authorities of the country of usage of the machine.

The electromagnetic field generated by the added system must not exceed 24 V/m at any moment and at any location in the proximity of electronic components and the network between them over the entire machine.

VIBRATION LEVEL INFORMATION

The vibration level for the arms to which the operator of this machine is exposed under normal operating conditions is below the 2.5 m/sec² weighted root mean square (RMS) value. The vibration level for the whole body is below the 0.5 m/sec² RMS value.

This information and measuring methods are in line with the European Machinery Directive 98/37/EC paragraph 3.6.3.

SAFETY DECALS

The following safety decals have been placed on your machine in the areas indicated. They are intended for your personal safety and for bystanders.

Safety decals are designed according to ISO 11684.

Please take this manual and walk around your machine, noting the location of the decals and their significance.

Review these decals and the operating instructions detailed in this Manual with the machine operators.

Keep the decals clean and legible. If they become damaged or illegible, obtain replacements from your New Holland dealer.

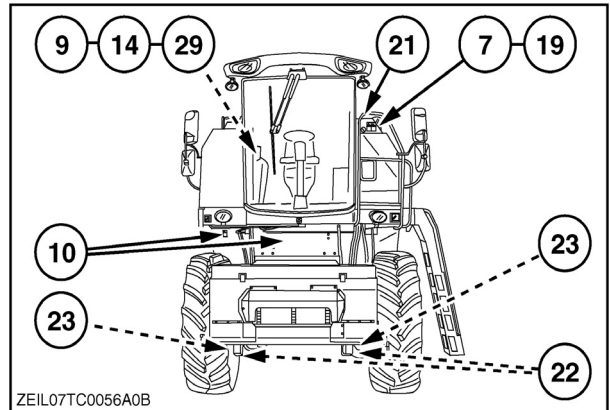

6

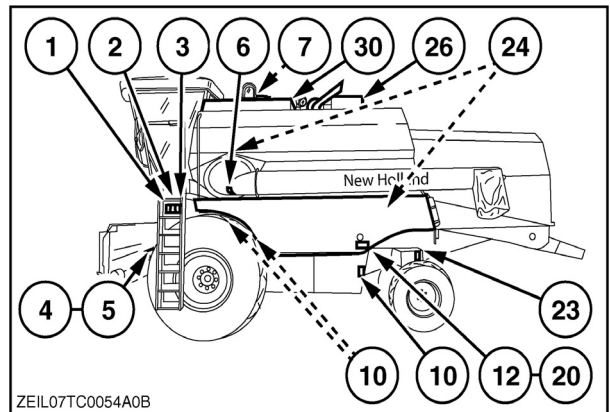

7

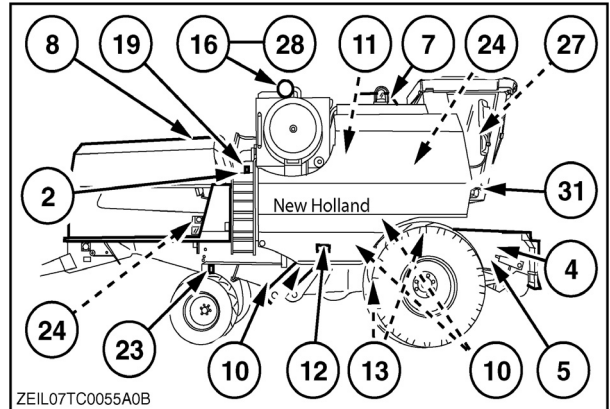

8

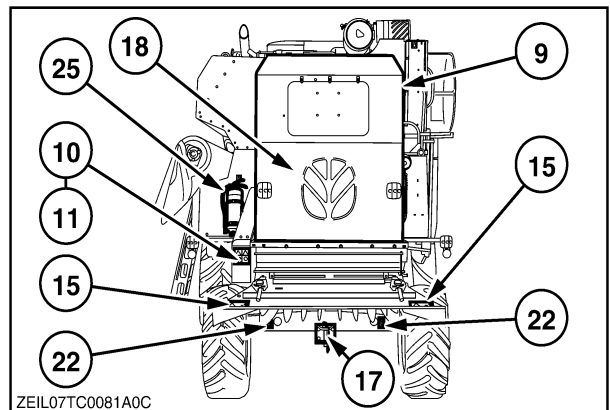

9

Decal 1



Carefully read the Operator's Manual before operating the machine. Observe instructions and safety rules when operating.

Decal 3



Disengage all drives, stop the engine and wait until moving parts have stopped before cleaning or servicing the machine.

Decal 2



Never ride on platform or ladder.

Decal 4

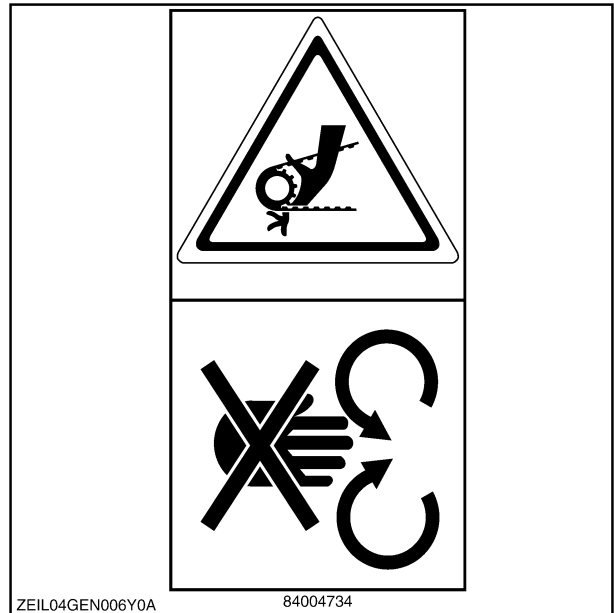

Never open or remove the safety shields while engine is running.

Decal 5

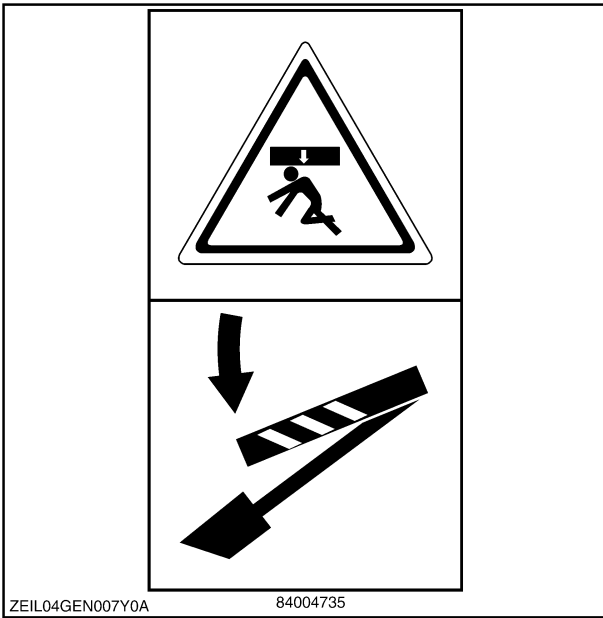

Secure lift cylinder locking device before getting in dangerous area.

Decal 6

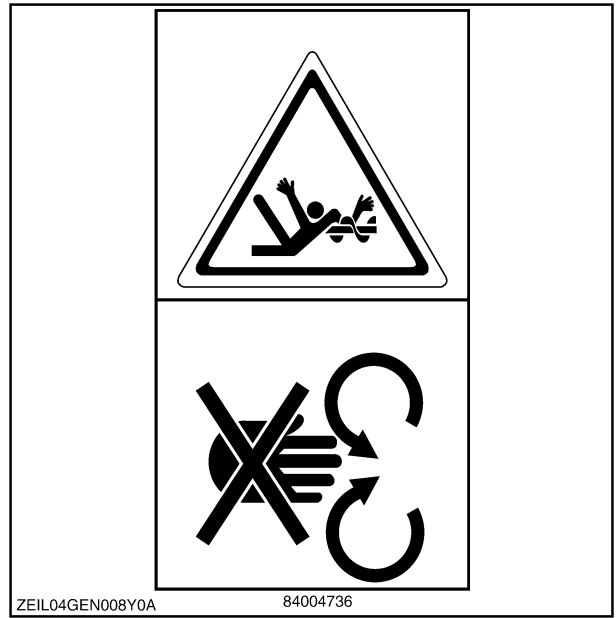

Never reach into rotating auger.

Decal 7



Never reach or climb into grain tank while engine is running.

Decal 8

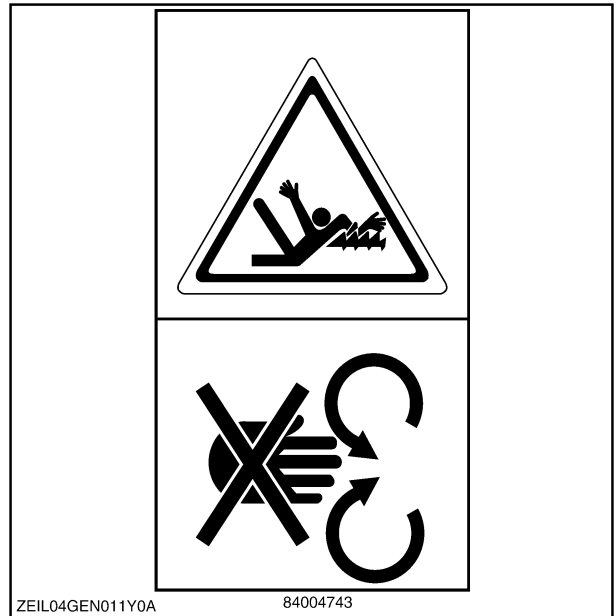

Never reach into straw walker while engine is running.

Decal 9



Shut off engine and remove ignition key before performing maintenance or repair work.

Decal 10

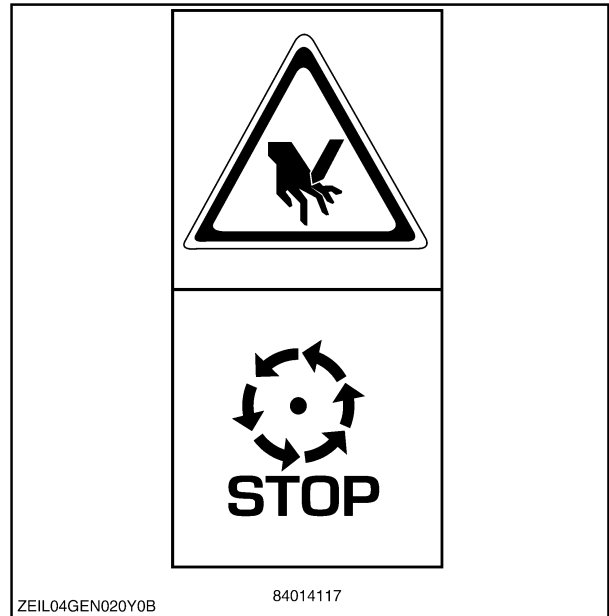

Wait until all machine components have stopped completely before touching them.

Decal 11

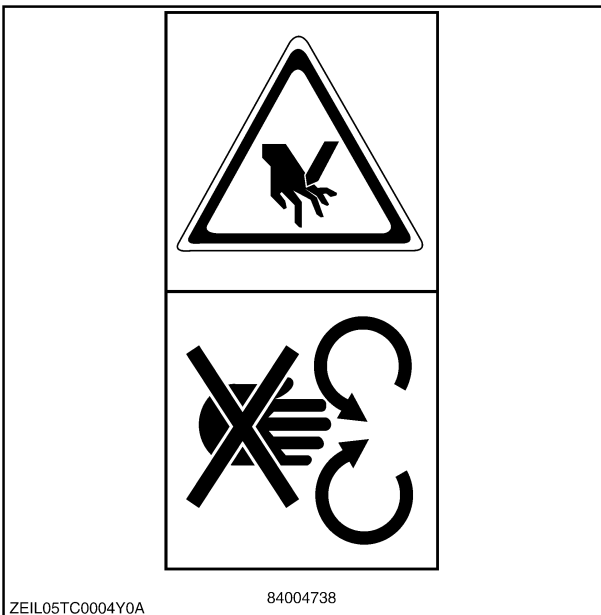

DANGER:
keep far from machine moving parts.

Decal 12

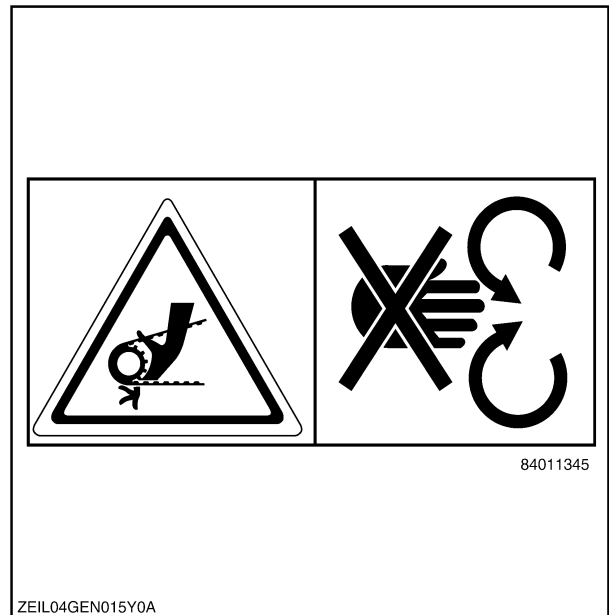

Never open or remove safety shields while engine is running.

Decal 13

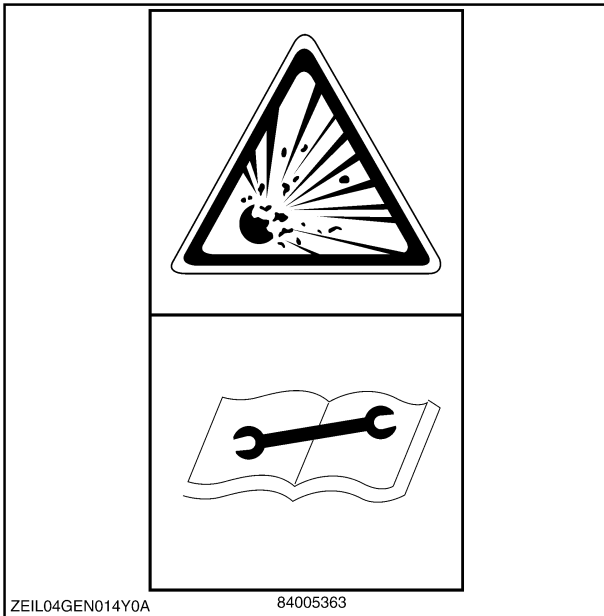

Hydraulic accumulators contain gas and oil under pressure. For removal and repair, contact your local New Holland dealer.

Decal 14

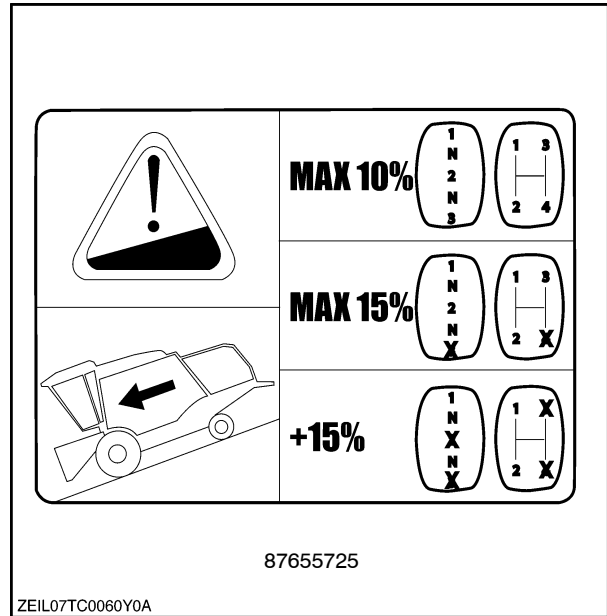

To prevent runaway of the combine (i.e. when the ground speed increases during downhill driving and it is impossible to reduce speed with the ground speed control lever), it is necessary to shift into a lower gear appropriate to steepness of the hill before starting the descent.

Decal 15

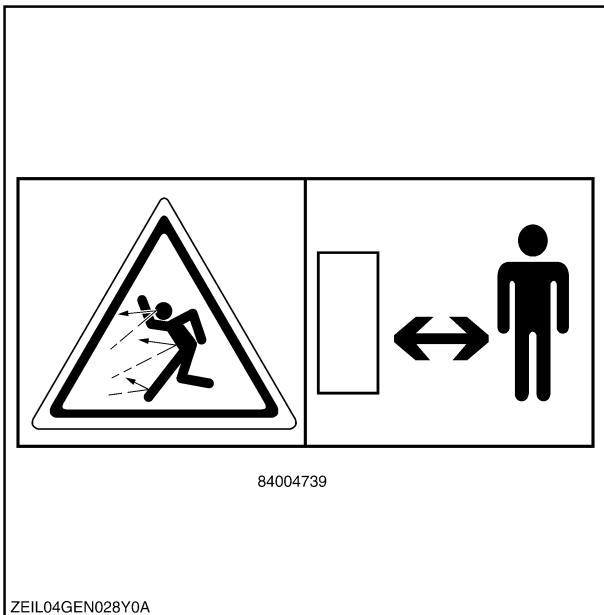

DANGER:
Stay clear while the engine is running.

Decal 16

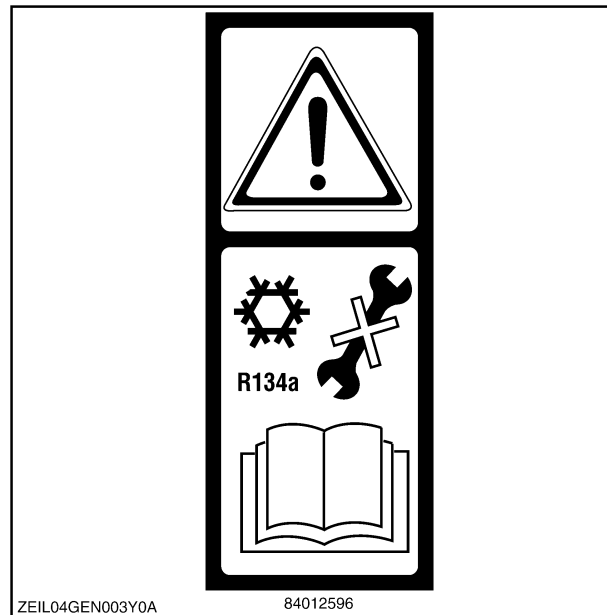

R134a cooling gas. For removal and repair contact your local New Holland dealer.

Decal 17

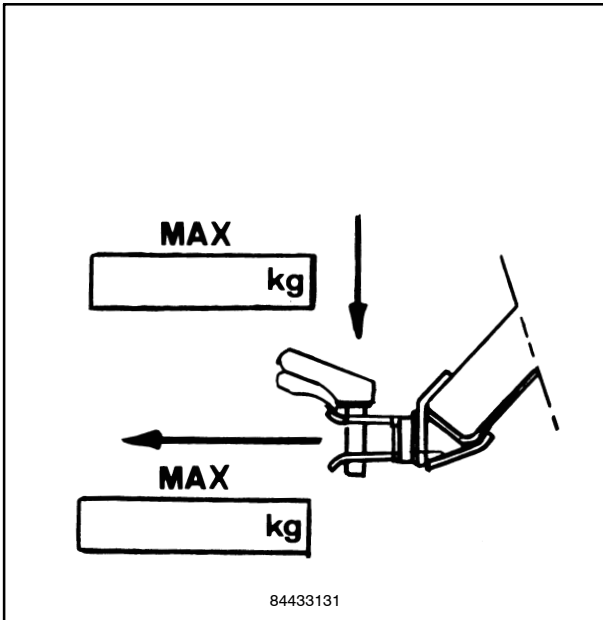

51894

This plate indicates:

1. The maximum allowed vertical force.
2. The maximum allowed horizontal pull force of the hitch.

Decal 18

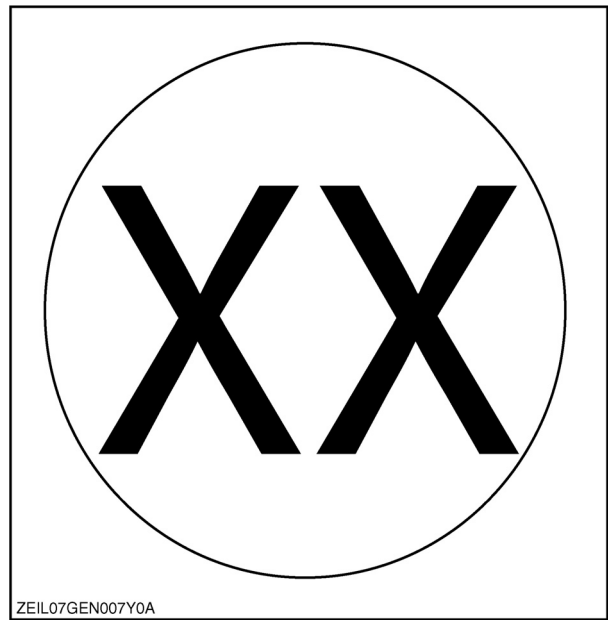

Maximum road speed limitation of the vehicle: "XX".

Decal 19



ZEIL05TC0005Y0A

Danger – Keep sufficiently far from electrical lines.

Decal 20

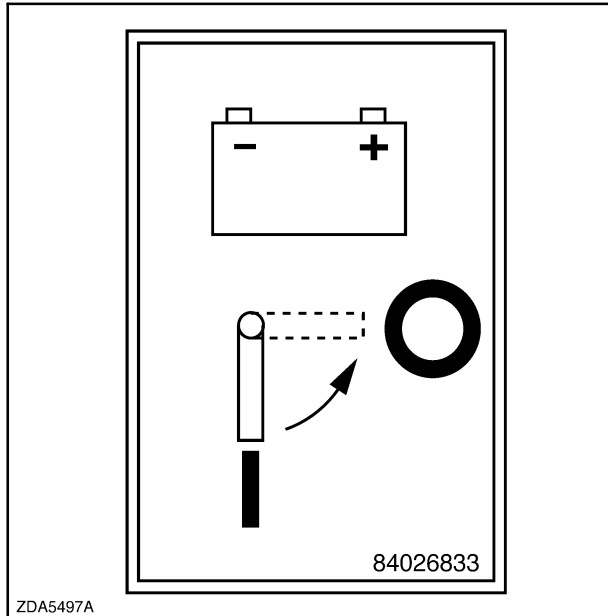

ZDA5497A

Battery key

Decal 21



Don't place foot.

Decal 22

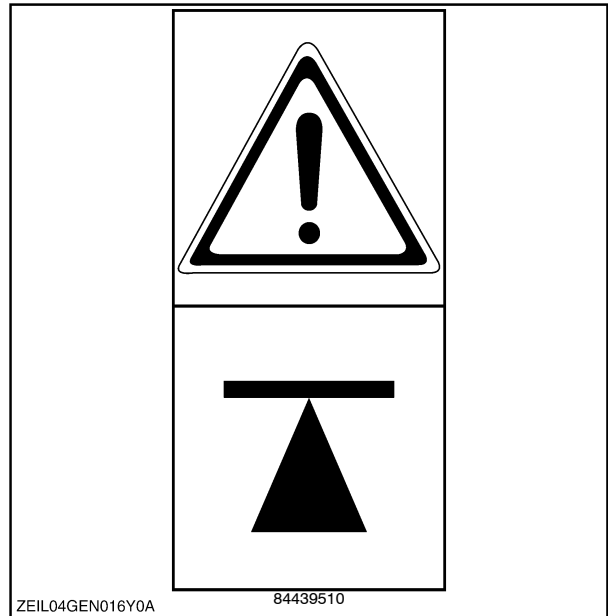

Jack-up point.

Decal 23

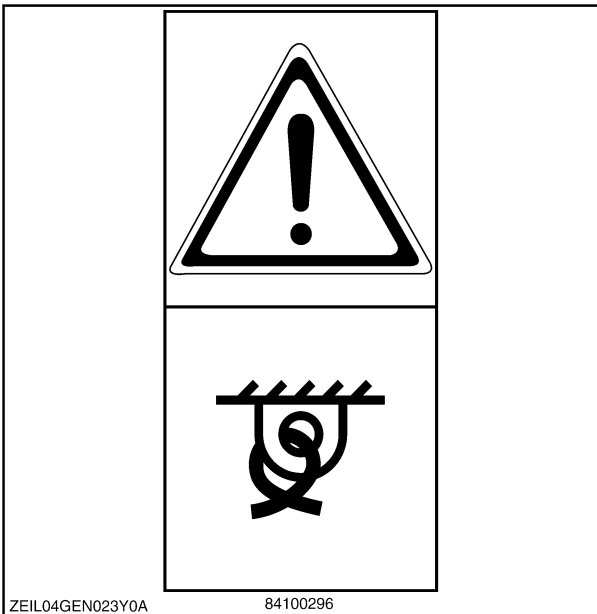

Tie-down eye.

Decal 24

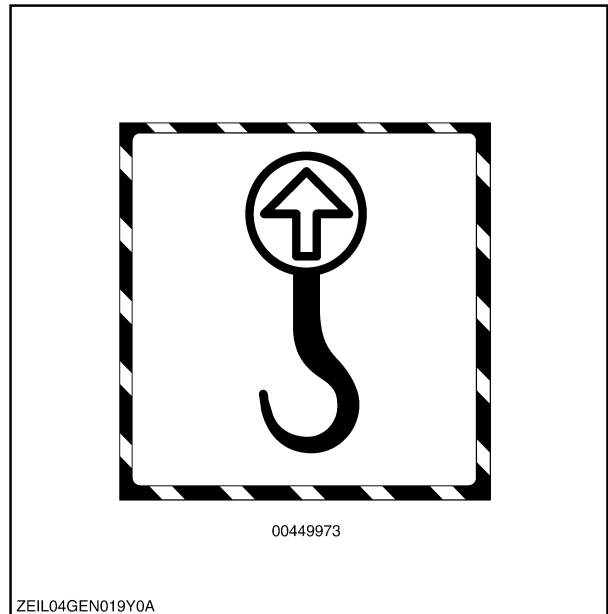

Lifting eye or pull eye.

Decal 25



Only operate when approved fire extinguisher is installed.

Decal 26



Stay clear of hot surface.

Decal 27

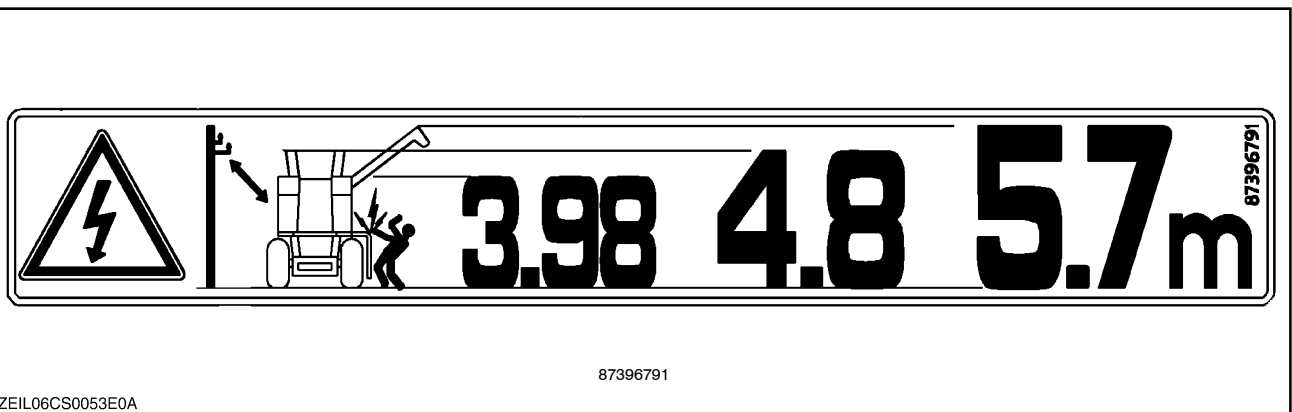

Overhead powerlines + height indication.
(Not for all countries)

Decal 28

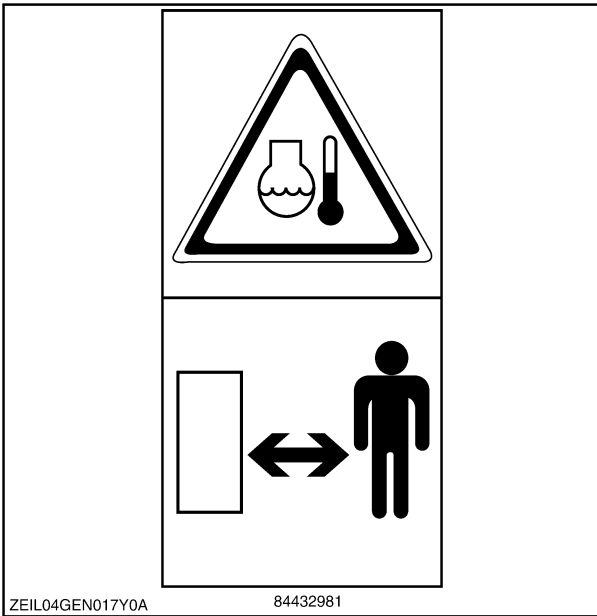

Hot coolant

Decal 29

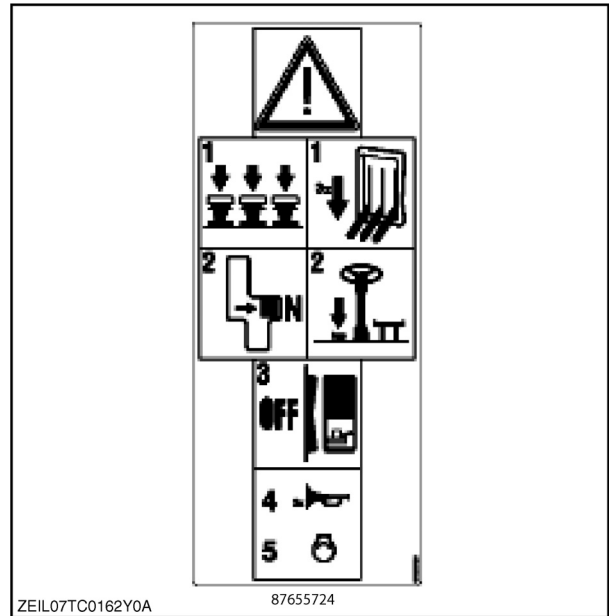

1. Disengage header, threshing mechanism and unloading system.
2. Place the hydrostatic handle in neutral or press down on the clutch pedal.
3. Set the unloading tube position tumbler switch in neutral position.
4. Sound the horn 3 times and wait for 10 seconds before starting the engine.
5. Start the engine.

Decal 30

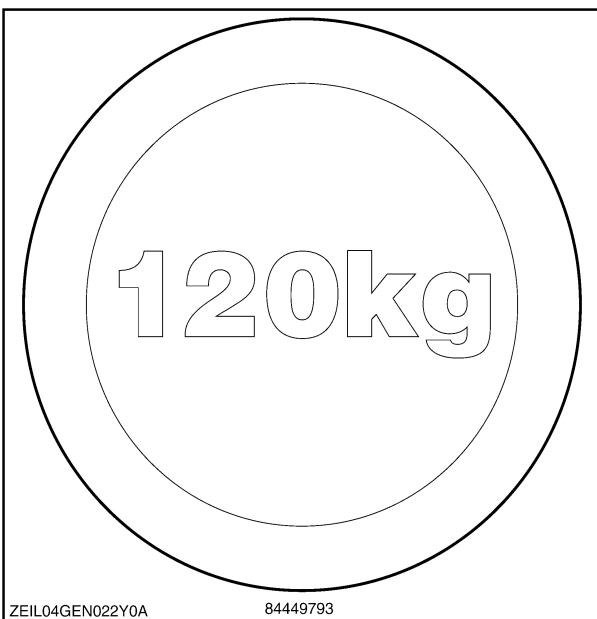

Maximum allowed weight to step on

Decal 31



Certification decal for Russia

PROTECTIVE DEVICES

Cylinder safety latch on straw elevator

The left-hand header cylinder is standard fitted with a safety latch which must be lowered onto the cylinder rod to prevent accidental lowering of the header.

For operations to be carried out under the lifted header, the cylinder safety latch must be moved from position (2) on the plunger to position (1).

After the use, place the cylinder safety latch in position (2) again.

IMPORTANT: Do not use the cylinder safety latch in position (1) as header support, when travelling along public roads otherwise damage may occur to the cylinder.

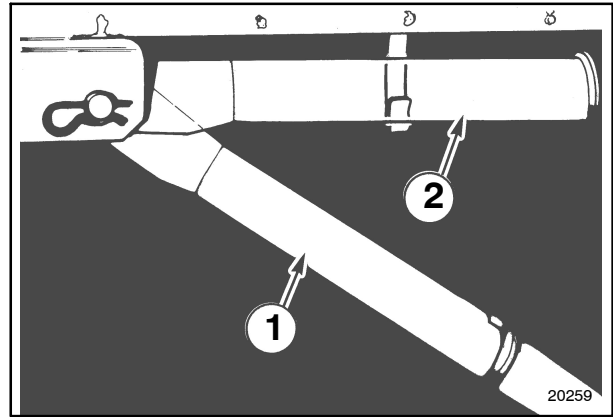

10

Header additional safety latch

In some countries a small safety latch (3) is fitted onto the right-hand side cylinder. It must be lowered onto the cylinder rod when driving on public roads to prevent accidental lowering of the straw elevator.

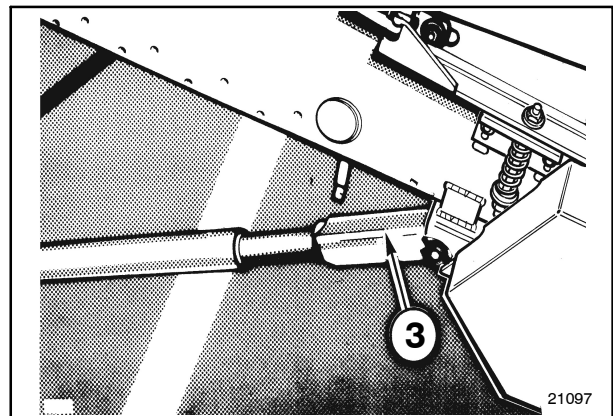

11

Straw elevator additional support

In some countries, there is a legal obligation to have an additional support (6) installed on the right-hand side of the straw elevator. This support must be placed in position (4) whenever the machine is driving on public roads.

After using it, the support (6) can be stored in the latch (5).

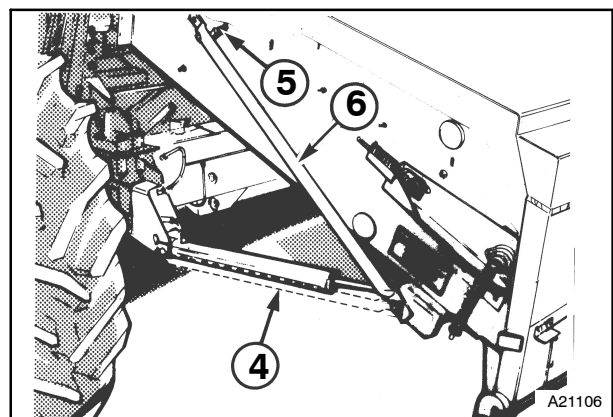

12

Wheel chock

In some countries, the metal wedges (7) are stored on the right-hand side of the straw elevator.

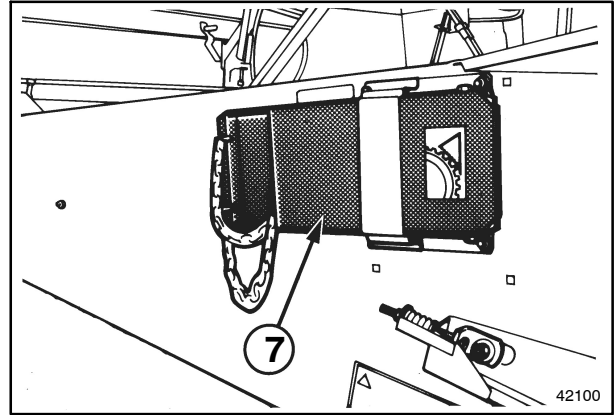

13

When the machine is parked on a nonlevel surface, the wedge (7) has to be placed at the lowest side against the traction wheel.



CAUTION



Never position the wedges against the steering wheels.

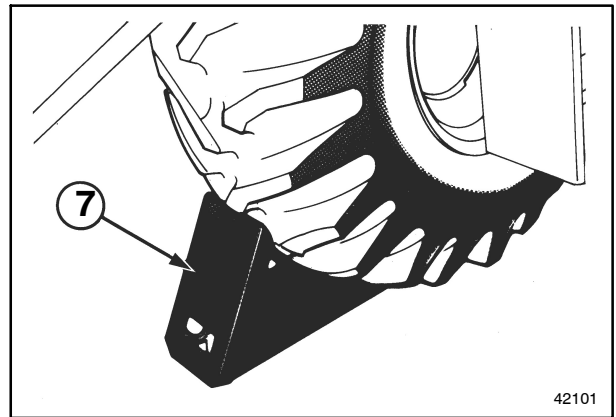

14

Safety guard for straw elevator

For some countries, the safety railing (8) must be installed for road transport and secured to the front of the straw elevator.

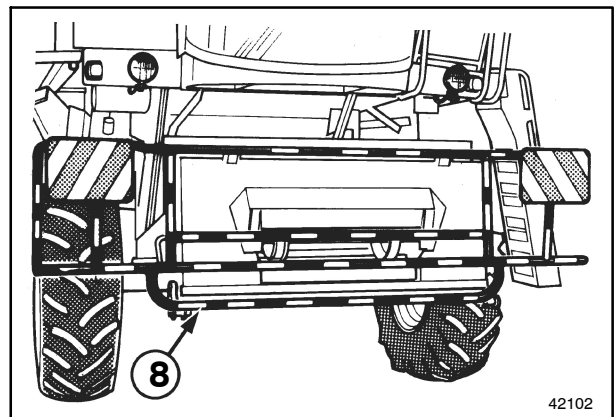

15

Signal plates

For some countries, signal plates (9) must be installed for road transport.

- At the front to the safety railing (8), if installed.

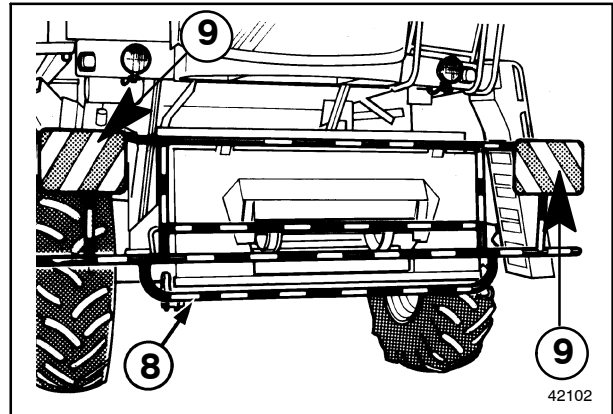

16

- To a profile fitted to the straw elevator.

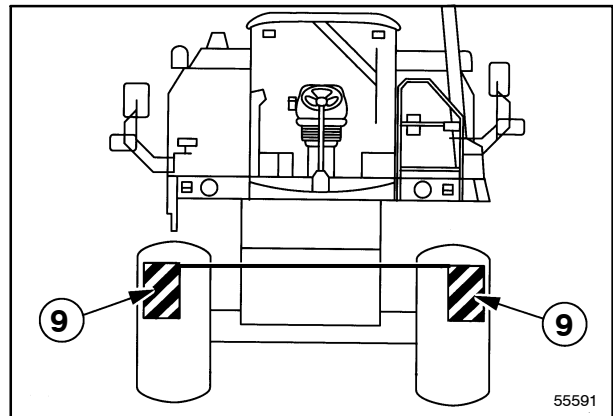

17

- At the rear to the light supports on both sides.

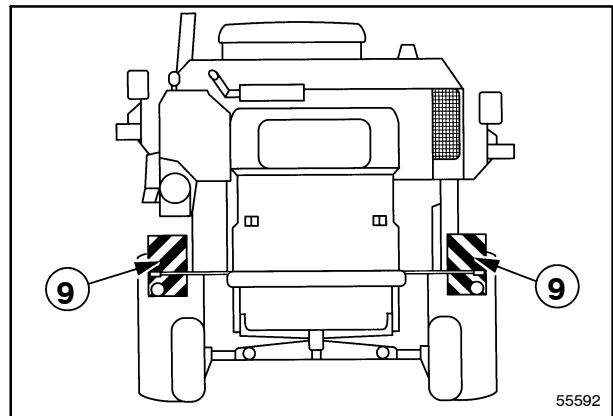

18

Reverse driving buzzer

At the right-hand side a buzzer is installed to inform people that there will follow an action with the combine.

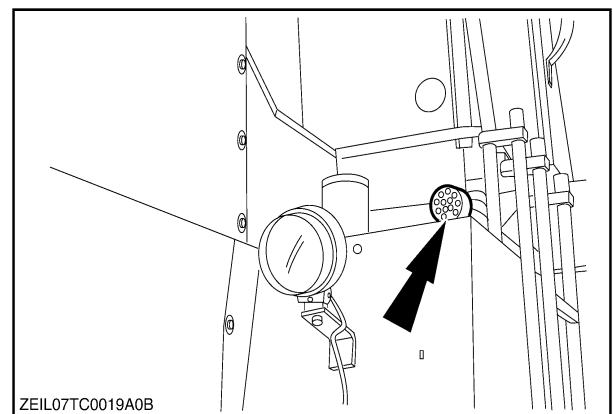

ZEIL07TC0019A0B

19

Safety guards

For safety reasons and according to the European directives, safety guards are now equipped with locking devices which can only be opened by means of the special tool (1) located on the left-hand side of the straw elevator.



CAUTION



DO NOT modify the guards and the locking devices.

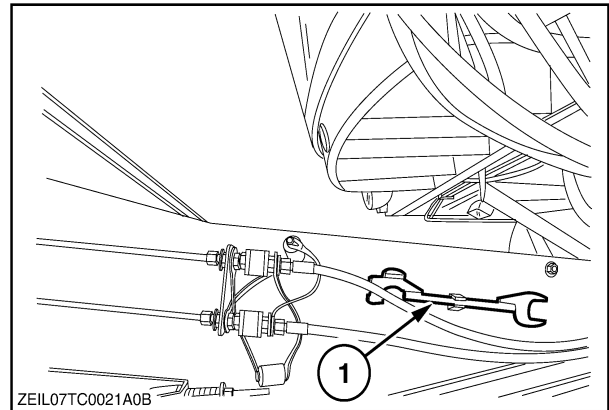

20

Straw chopper spreader chute

While driving on public roads, the straw chopper spreader chute must be kept in operation position (as shown), if the combine is not pulling a header trailer.

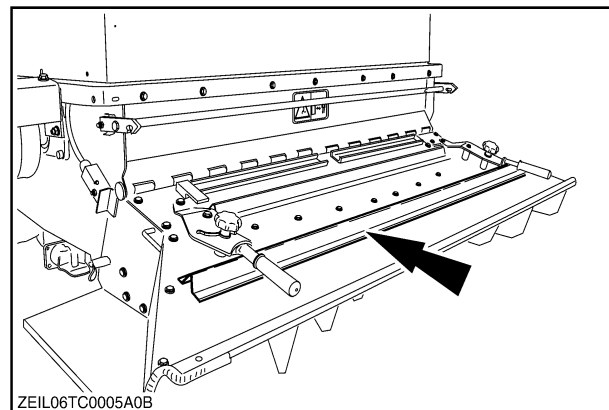

21

Fire extinguisher (if installed)

The fire extinguisher is located on the left-hand side near the straw hood.

Check the extinguisher pressure at least once a year before the start of the season.

To check if the extinguisher is still under pressure, proceed as follows:

1. Unscrew the pressure gauge from the valve.
2. The needle will go from the green area to "0" in the red area.
3. Rescrew the pressure gauge on the valve. The needle will go from "0" in the red field to the green field.

If the needle remains in the "0" of the red field, the extinguisher has a leakage. The extinguisher has to be repaired by a recognised extinguisher dealer.

Once the extinguisher is discharged, no matter for how long, it must be recharged.

The decal on the fire extinguisher is explained below:

- The extinguisher can be used and has been tested at temperatures of -20°C (-68°F) and $+60^{\circ}\text{C}$ ($+140^{\circ}\text{F}$).
- The type of the extinguisher "PKD 6", this means: Dry chemical powder and the capacity is 6 kg (13.2 lbs).

1. Remove the safety pin.
2. Aim nozzle at base of fire.
3. Press on the handle.

The extinguisher can be used on

- "A" class fires = dry fires
- "B" class fires = liquid fires
- "C" class fires = gas fires

- After use of the extinguisher on a fire, the pressure gauge needle will go to zero pressure.
- Do not try to repair or refill the extinguisher yourself. Bring the used or leaking extinguisher to a recognised extinguisher dealer.
- Do not use the extinguisher on objects under electrical tension of more than 1000 Volt and at less than one meter (3,3 ft) distance.

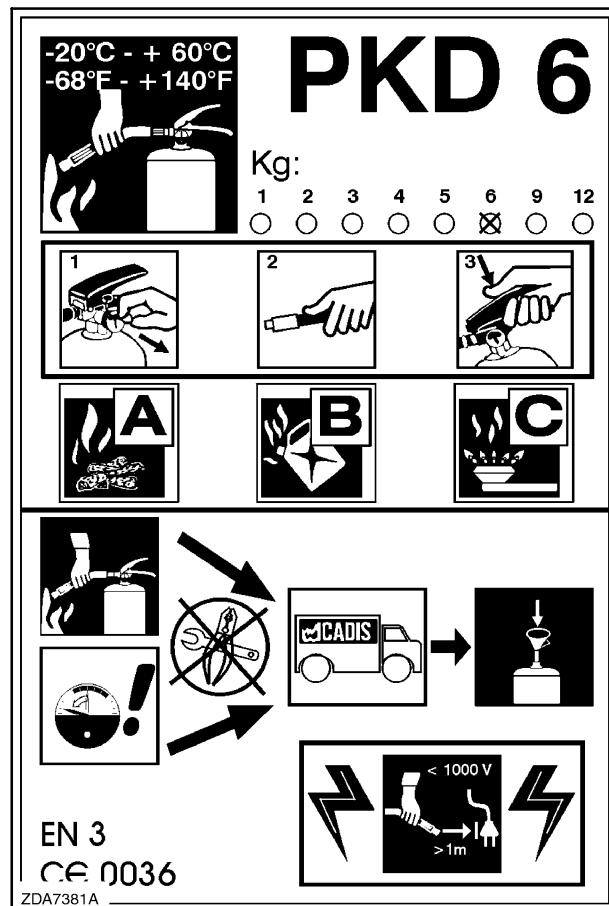
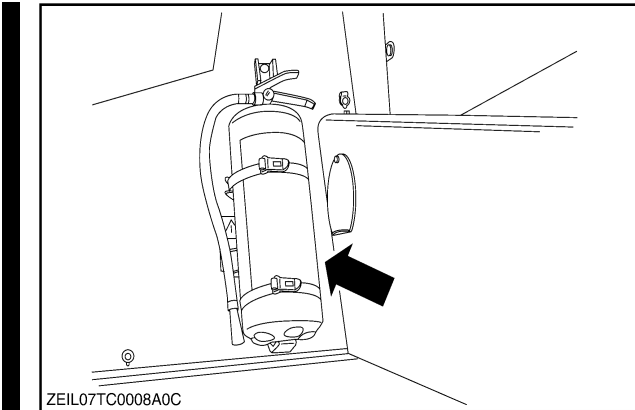

ACCESS TO MACHINE COMPONENTS

- Access to operator's platform

! DANGER !

Never allow anyone to stand or hang on the combine access ways while the combine is in motion. These access ways are only provided for entering and servicing the (stopped) combine in a safe way.

! CAUTION !

Always mount and leave the combine in a safe way, i.e. use the steps and guard rails provided and maintain a 3-point contact at all times.

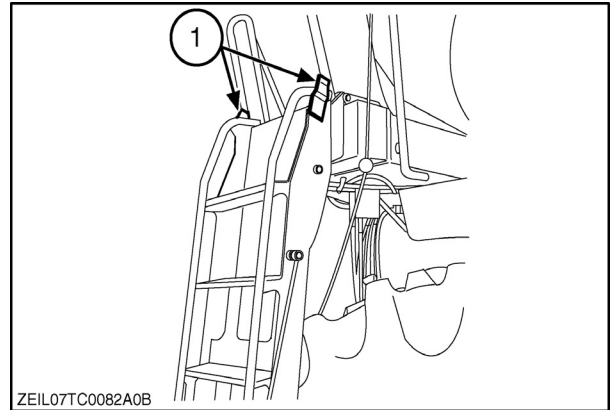

24

Pull up the ladder for road transport and secure it with the hook (2) provided on the operator's platform.

The bracket (1) can be adjusted by loosening the bolts so that the ladder stands vertical in the pulled-up position.

! DANGER !

Make sure bystanders cannot be hit when lowering the ladder.

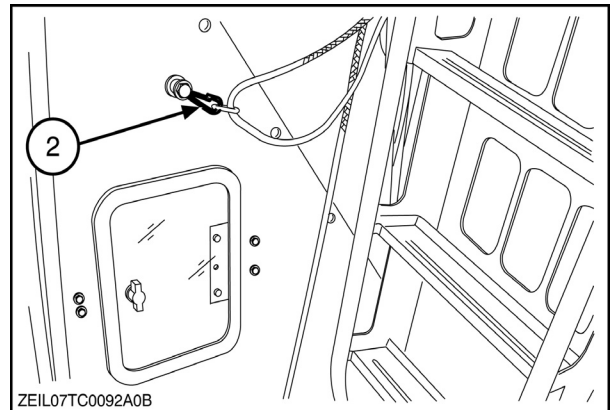

25

The ladder can pivot at (1) when the combine is advancing or reversing and the ladder contacts an obstacle. The pivoting force is adjusted with the springs (2). The spring length should be 63 mm (2 - 1/2").

! DANGER !

Never jump on the ladder when the combine is advancing as the ladder may pivot away.

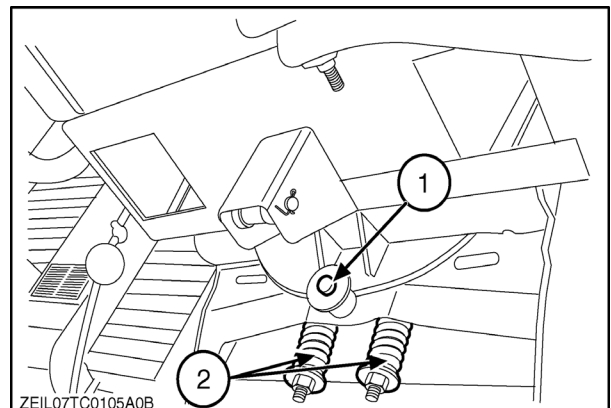

26

SECTION 1 – GENERAL INFORMATION AND SAFETY

- Step (1) provided to allow opening of the grain tank cover at the front side. (If installed)

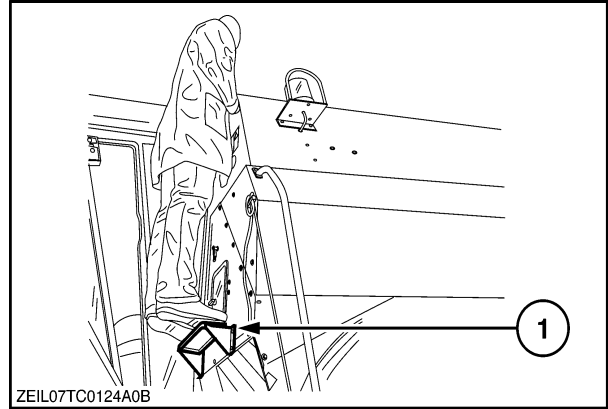

27

- Access to the straw elevator to enable cleaning of the cab windscreen.

Raise the header to its highest position and engage the header safety latch. Step on the straw elevator and keep your hand on the rail (1) on top of the cab.

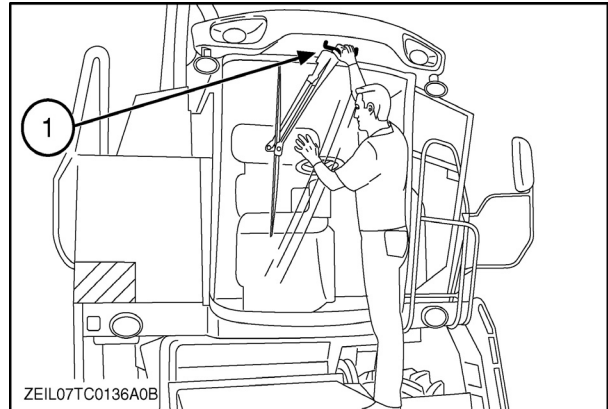

28

- Access to the engine compartment, to the fuel tank filler cap and to the straw walkers.

Proceed as follows:

1. Pull the latch (1) out of the clamp (2) and ensure latch (1) falls down in support (3).

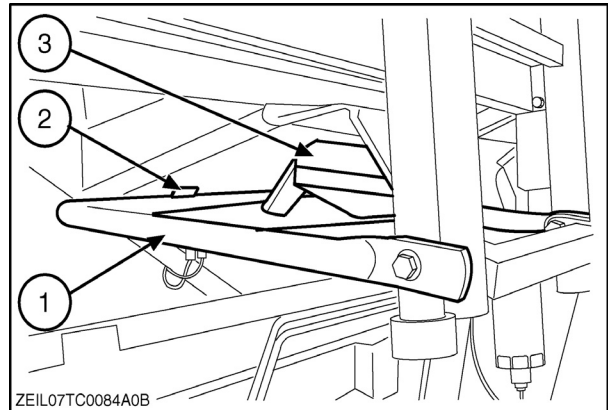

29

2. Lower the lowest part (4) of the ladder.



CAUTION



Raise the ladder and ensure latch (1) is secured by the clamp (2) when travelling on public roads and also when working in the field.

IMPORTANT:

If mechanical control: Lowering the rear ladder when the engine is running will cause to stop the engine. Be aware that if the engine is running with the rear ladder in lowered position, the engine protection is not working.

If remote control: Lowering the rear ladder when the threshing is engaged will cause to stop the threshing mechanism.

3. Step on the engine compartment and antislip strips on the grain tank are provided to have access to the grain tank at the rear side. Use the hand grip to step on to the engine compartment.



CAUTION



Never stand up on the engine.

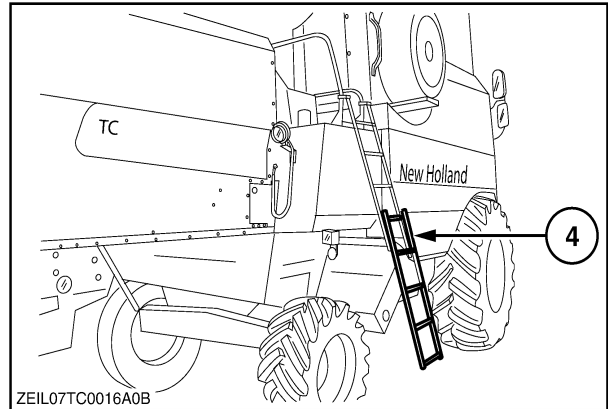

30

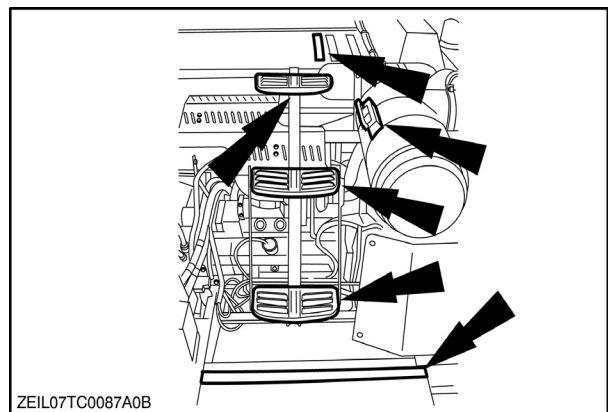

31

- To reach the grain tank, proceed as follows:
 1. Stop the engine, remove the ignition key and engage the parking brake.
 2. Access to the grain tank cover from the engine platform getting on the anti-slip steps.
 3. Open the grain tank cover by tilting it rearwards.
 4. Lift the safety guard (1) out of the hooks (2). Push the safety guard rearwards and let it hang down in the grain tank.
 5. In case of five straw walker combine, use the steps to climb inside the grain tank.

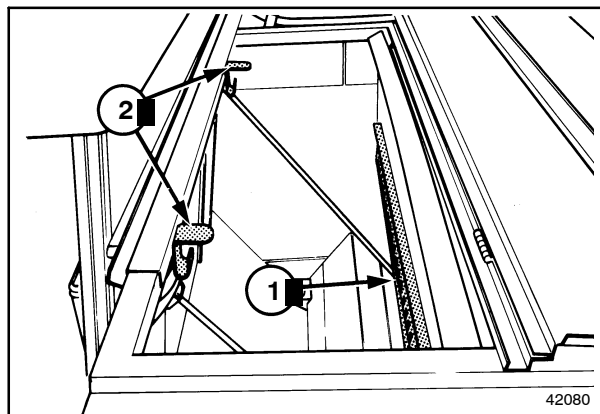

32

- Shielding (left and right-hand side)
Open the shielding (1) by using the special tool. To open: Turn first the nut a quarter counter clockwise with the special tool to unlock the shielding.

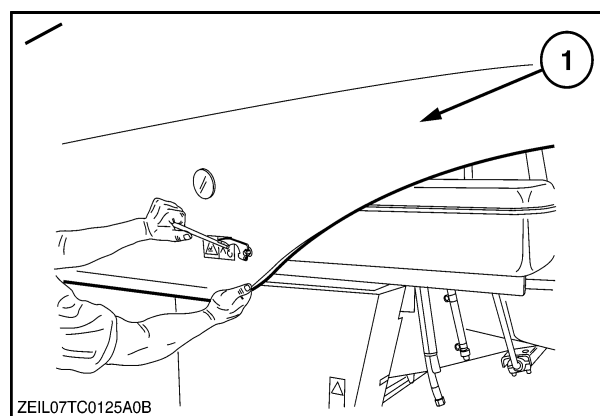

33

Right-hand side covers

- Access to adjust the grain elevator transport chain (only TC5070 and TC5080)
Remove the cover (1) by turning the four slots (2).



CAUTION



Adjust the drive chain tension from inside the grain tank.

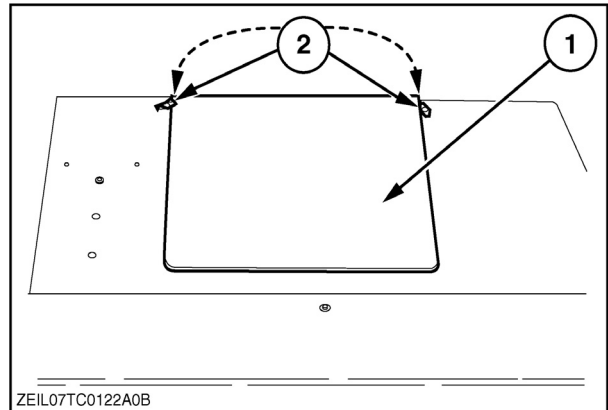

34

Left-hand side covers

- To have access to the grain returns cross auger and elevator drive chain.
Open the cover (1), by unlocking the lever (2).

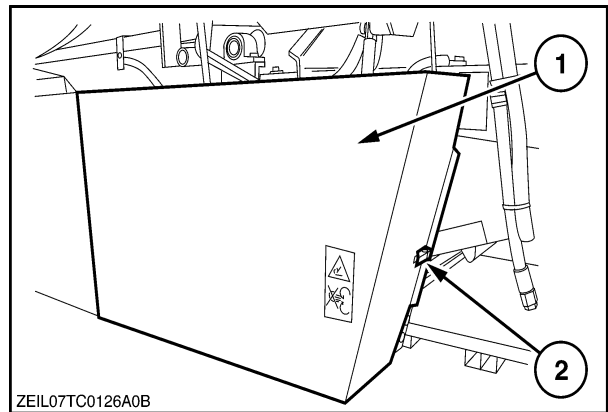

35

- Open the cover (1) (if rotary separator installed) to have access to the grain pan and rotary separator concave.

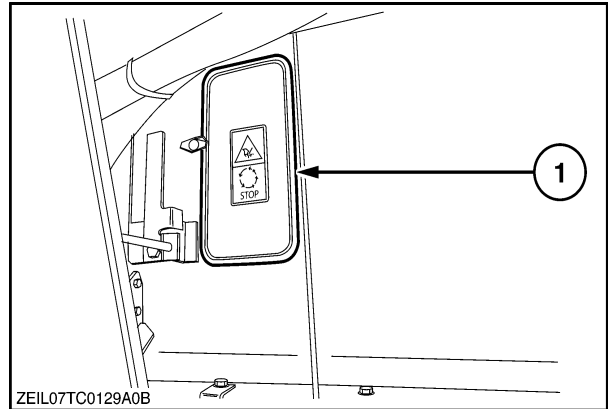

36

■ To open the cab roof, proceed as follows:

1. When pulling the handle (1) down (in the cab), the cab roof (2) (fig. 38) will open.

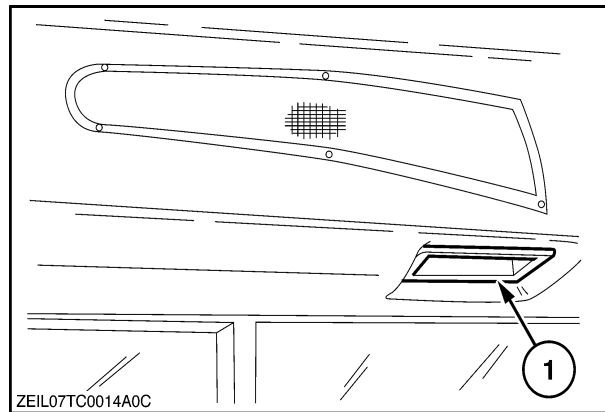

37

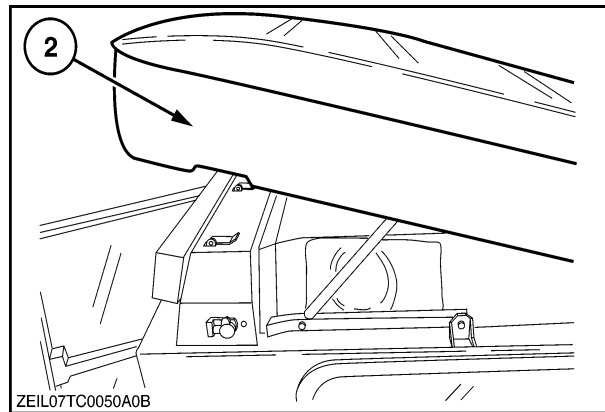

38

2. Push the cab roof further up until the supports (3) open the cab roof completely.

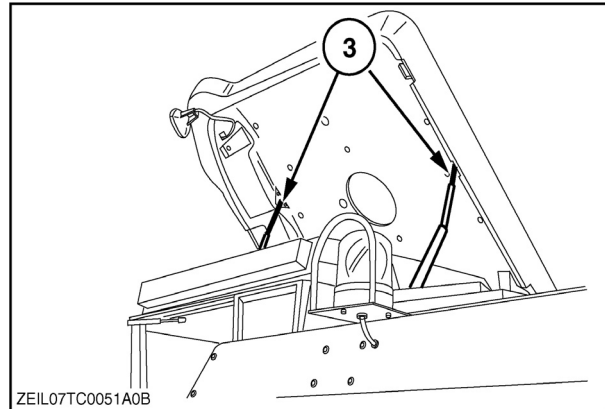

39

■ To close the cab roof, proceed as follows:

1. Pull back both supports (3) and push down the cab roof (2).
2. The cab roof (2) is completely closed when you hear it lock in place.

ATTACHING A TRAILER

A hook is foreseen on the top of the trailer hitch support to pull a trailer with a cable to the combine to attach.

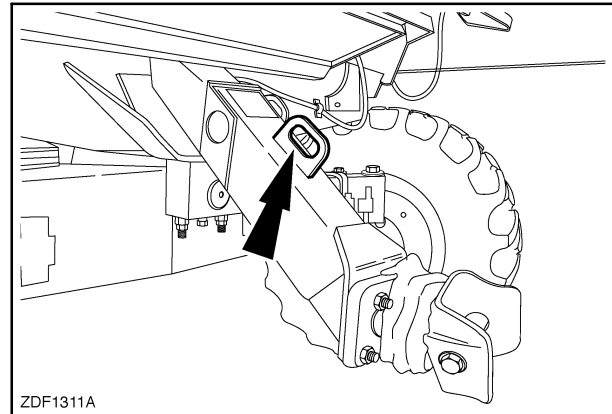

40

TOWING THE COMBINE

Towing the combine is not recommended, but if it must be towed, the following steps must be taken:

1. In case of hydrostatic drive: Move the multi-function handle into neutral position.
2. Select neutral gear.
3. Release the parking brake.
4. Provide adequate warning signals to make other road users aware that the combine is being towed.
5. Tow at a maximum speed of 16 km/h (10mph).

NOTE:

1. *Towing the combine with hydrostatic drive and selected gear will immediately lead to irreparable hydrostatic damage.*
2. *Should the combine become stuck in the mud, always tow the combine with a cable or chain attached to the traction axle. Do not tow the combine with a cable attached to the steering axle.*

LIFTING THE COMBINE

To lift the combine (for example to load the combine on a trailer for road transport) there are lifting hooks:

- At the front

Two lifting hooks are located in the grain tank.

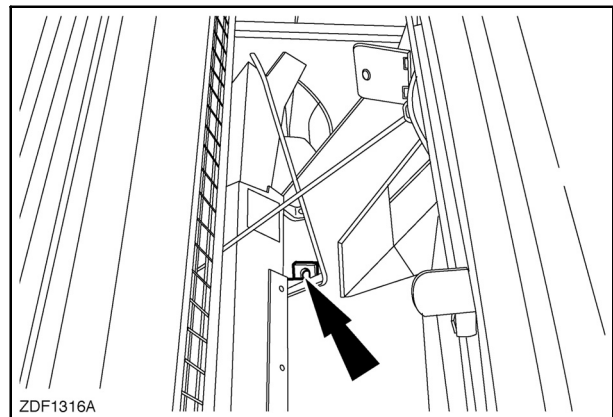

41

- At the rear

Two lifting hooks are located at the left and right-hand side on the top of the upper frame of the straw walker section.

NOTE: Use long ropes or cables to lift the combine, to avoid damage to the combine.

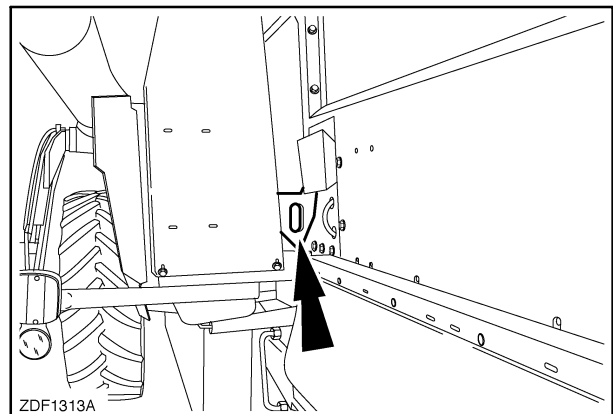

42

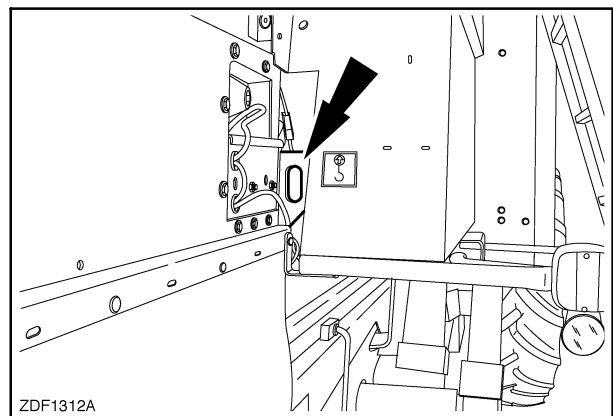

43

TIE DOWNS FOR SHIPPING

To hook-up the combine (e.g. trailer) proceed as follows:

Install the combine on a trailer and support the front and rear axle with wooden blocks as wide and as low as possible.

- At the front:

They are two holes foreseen at the left and right-hand side straw elevator lift cylinder support.

- Tie-down with a rope or a chain in cross-bond.

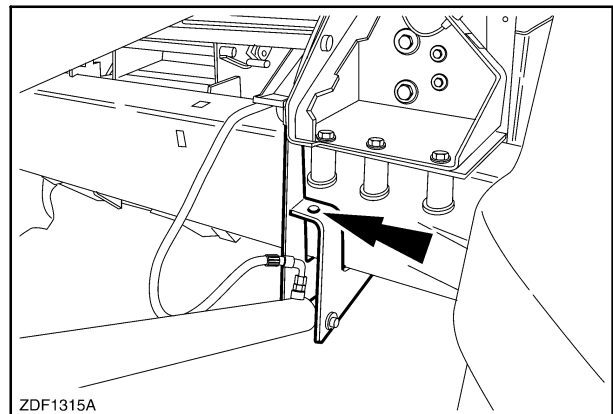

44

- At the rear:

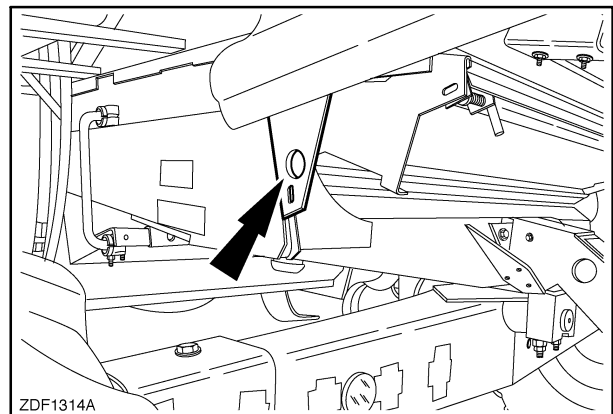

45

ADJUSTMENT OF THE DIMMED LIGHTS

The dimmed lights are “factory adjusted” with a level standing combine.

However to adjust the dimmed lights, proceed as follows:

1. Park the combine on a perfect level surface and about 5 meter (16 ft) from a perpendicular square dark wall.
2. Lower the straw elevator.
3. Measure distance A. (A=distance from the ground to the centre of the lamp)
4. Measure distance L. (L= distance from the light to the wall)
5. Distance C should be maximum = $A - (L \times 0.07)$

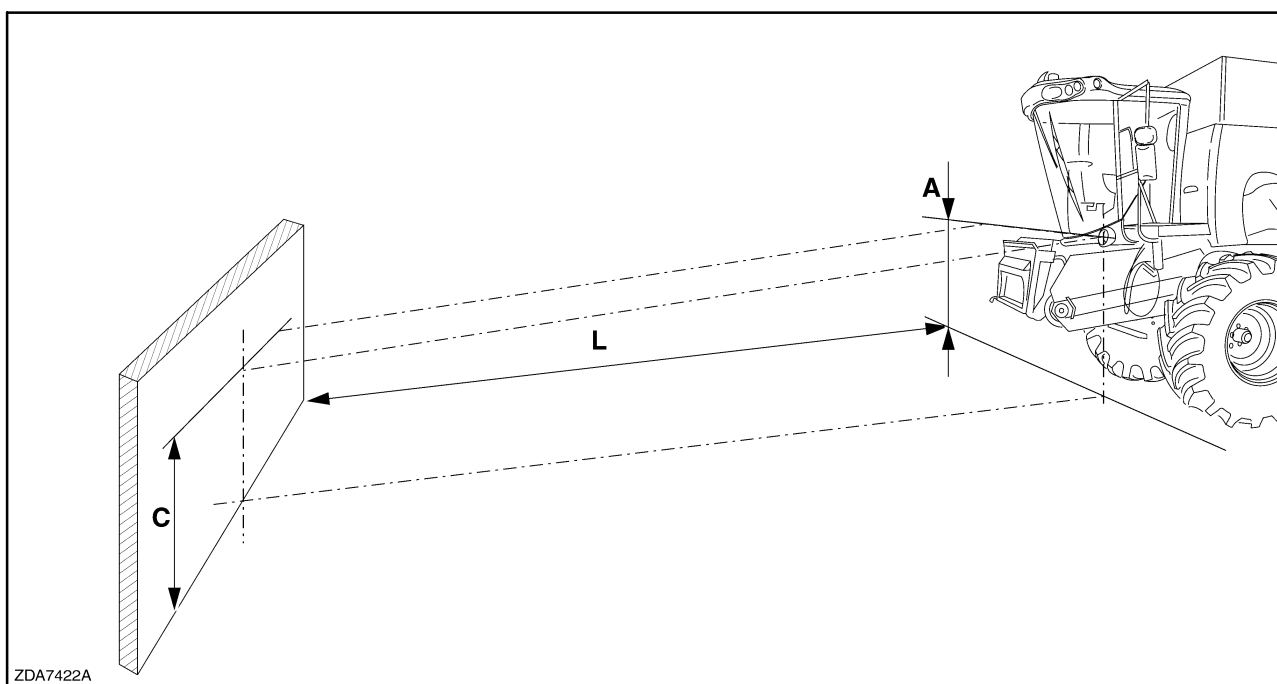

46

6. Adjust the light by loosening the nut (1).

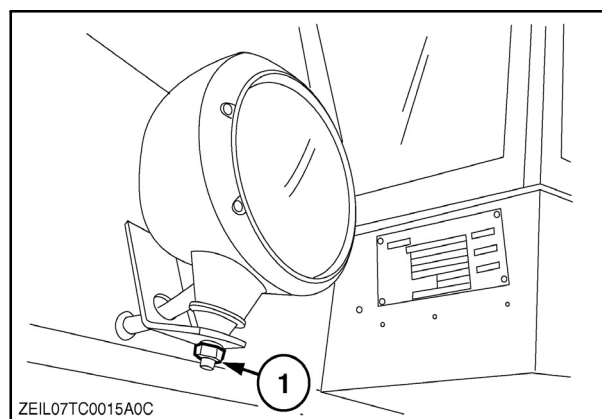

47

ATTACHMENT COMPATIBILITY

The combine can be equipped with the headers shown here below:

HEADERS	TC5040	TC5050	TC5060	TC5070	TC5080
High-Capacity Grain Header					
12 ^{ft}	x	x	x	x	x
13 ^{ft}	x	x	x	x	x
15 ^{ft}	x	x	x	x	x
17 ^{ft}			x	x	x
20 ^{ft}					x (1)
Maize header					
MR570N			x	x	x
MR575W			x	x	x
MR580W			x	x	x
MR670N				x (2)	x
MR675N				x (2)	x
MR675W				x (2)	x
MR680W				x (2)	x
MF670N				x (2)	x
MF675N				x (2)	x
MF675W				x (2)	x
MF680W				x (2)	x

(1): former C.I.S. countries

(2): In case of heavy duty traction

This is the logic of the maize headers

Position 1:	M	Maize header
Position 2:	R or F	Rigid or Flip-up
Position 3:	5, 6 or 8	Number of rows
Position 4 and 5:	70, 75 or 80	Row distance in cm
Position 6:	N or W	Narrow or Wide frame

SECTION 2 – CONTROLS, INSTRUMENTS AND OPERATION

CAB AND CONTROLS

Cab door

To open the door from the inside, press onto the lever (1).

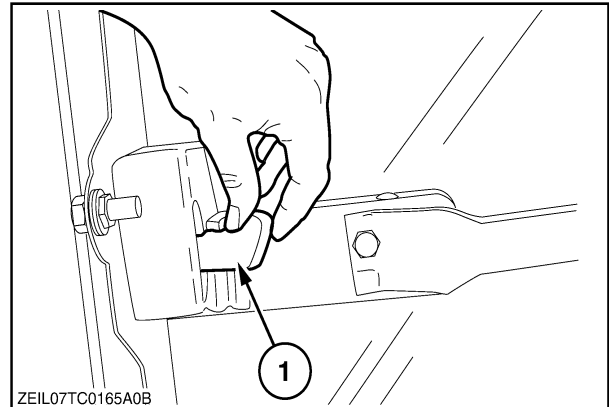

1

Emergency exit

The right-hand window is the emergency exit.

In case of emergency, break the right-hand window with the hammer (2).

Remove glass splits from the frame with feet and elbows.

Leave the cab passing over the instrument panel.

Use the mirror support as a handhold and the traction tyre to step on.

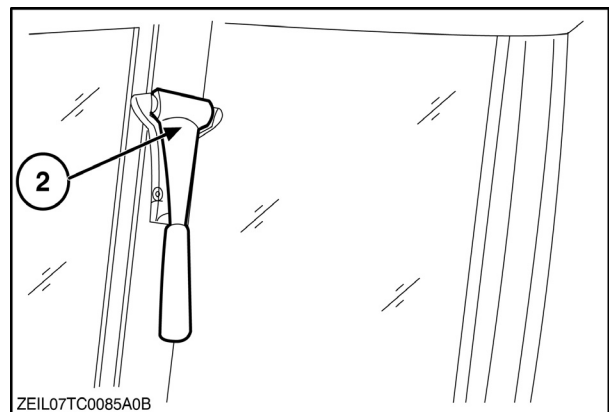

2

Clutch pedal (TC5040 – TC5060)

The clutch pedal (8) should be used in the following cases:

- To start the engine
- To select a gear, press down on the clutch pedal (8) and engage required gear.
- To move or stop the combine.
- If it is necessary to make an emergency stop, the clutch pedal (8) may be actuated while in gear simultaneously with the brake pedals.

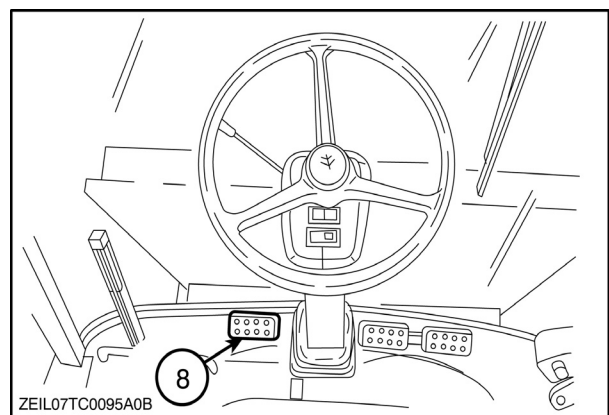

3

NOTE: Do not use this device on a downward slope. Always use the clutch pedal (8) simultaneously with the brakes.

Operator's seat and surroundings

1. Standard seat

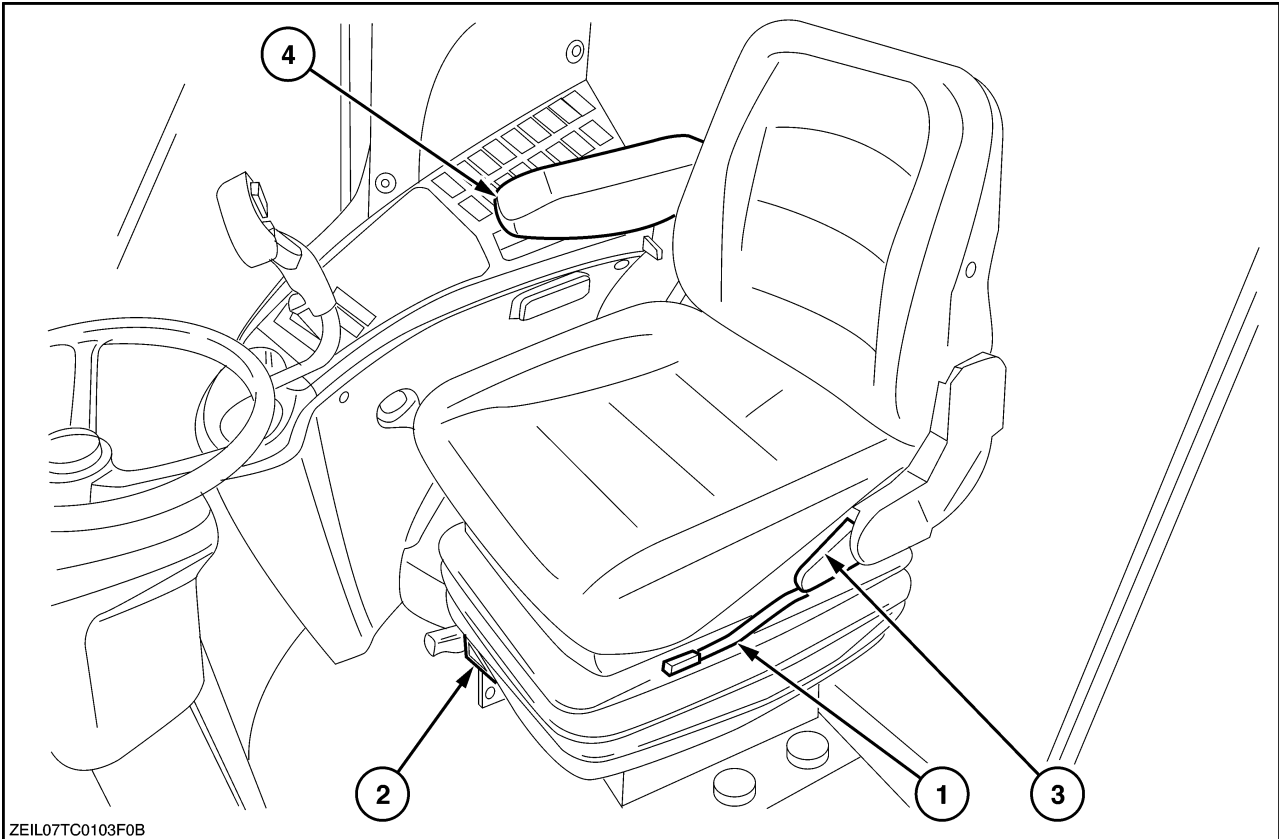

1. Operator seat fore and after adjustment
2. Weight adjustment with weight indicator
3. Seat back rest inclination adjustment
4. Armrest

⚠ WARNING ⚠

- In case of remote control: When the operator leaves the operator's seat for more than seven seconds, the header/straw elevator will be disengaged.
- In case mechanical control: When the operator leaves the operator's seat for more than five seconds, the engine will be shut off.

2. Air-suspended seat

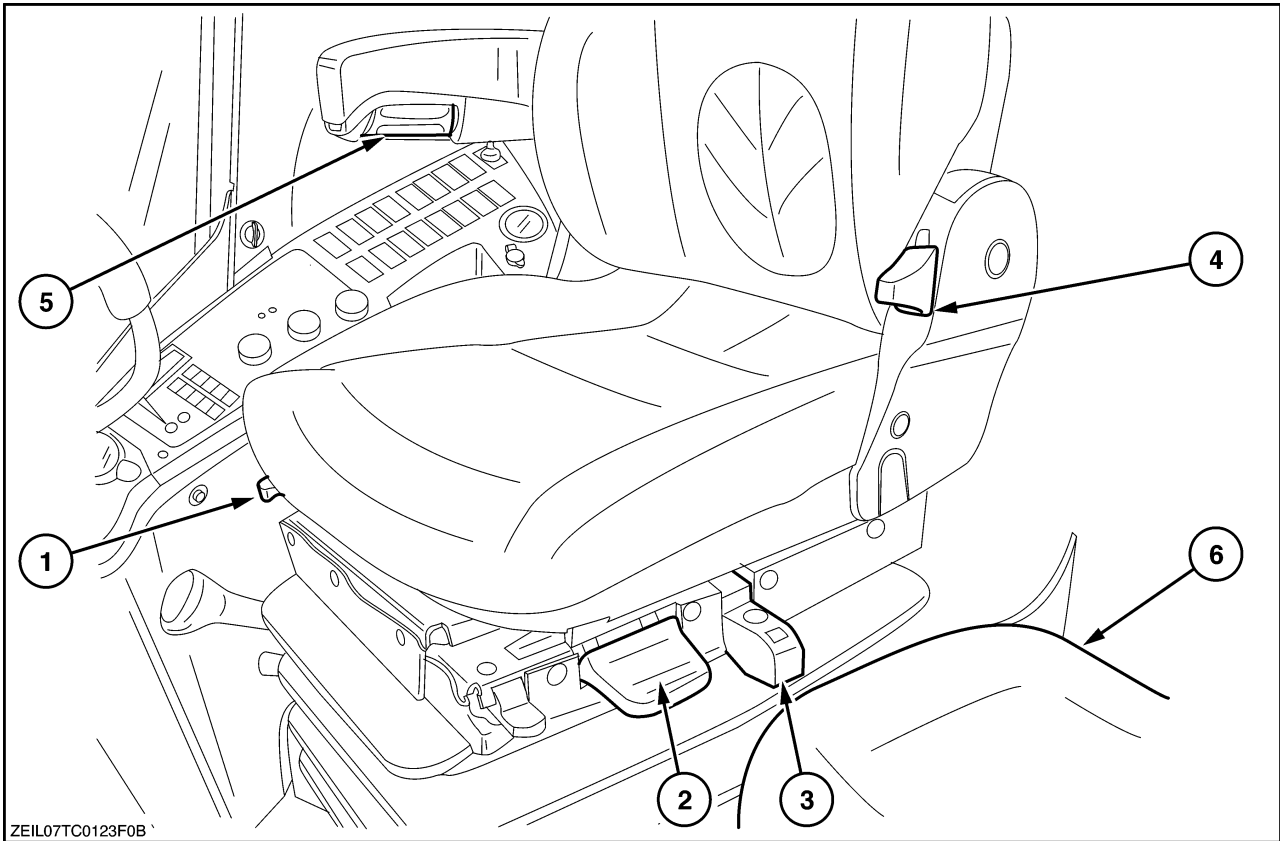

5

1. Operator seat fore and after adjustment
2. Weight and seat height adjustment (air suspension)
Weight adjustment: Lift or press the lever until the green marking at the weight/height indicator (3) is visible.
Height adjustment: Lift or press the lever until the required position is adjusted (the green marking is visible).
3. Weight/height indicator
4. Lumbar adjustment
5. Armrest angle adjustment
6. Instructional seat



When the operator leaves the operator's seat for more than five seconds, the header/straw elevator will be disengaged.

SECTION 2 – CONTROLS, INSTRUMENTS AND OPERATION

1. Parking brake
2. Concave control lever
3. Gearshift lever
4. Throttle lever (only TC5040–TC5050–TC5060)
5. Storage space for Operator's Manual/bottle holder

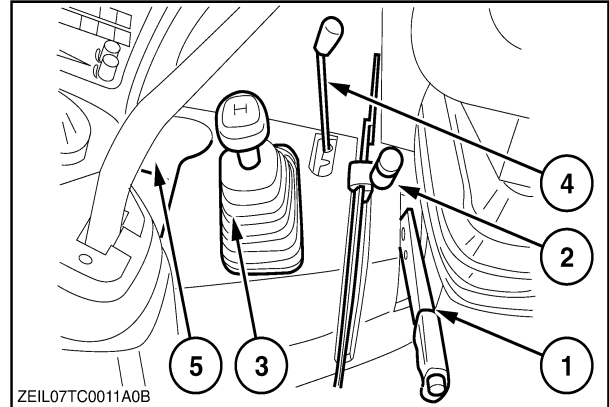

6

6. Header engaging lever (if applicable)
7. Threshing mechanism engaging lever (if applicable)
8. Unloading system engaging lever (if applicable)
9. Windshield washer reservoir (if installed)
(Use windscreen washer liquid
"TUTELA PROFESSIONAL SC 35")
10. Brake fluid level
11. Clutch fluid level (only TC5040–TC5060)

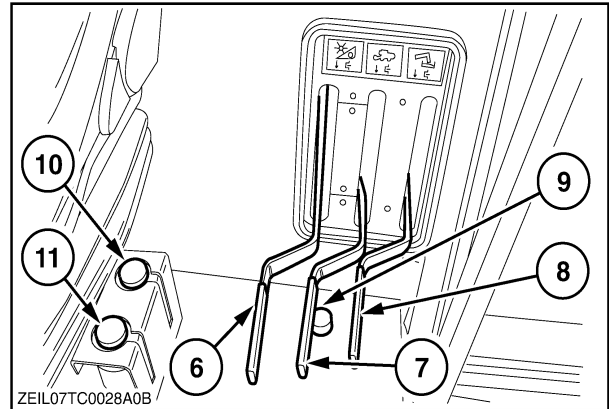

7

12. Fuse and relay panel cover

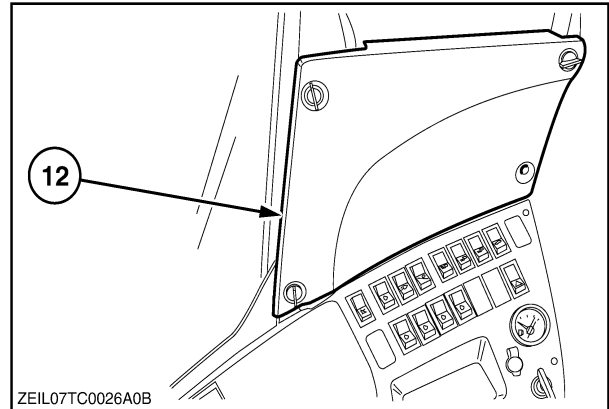

8

Steering column and control pedals

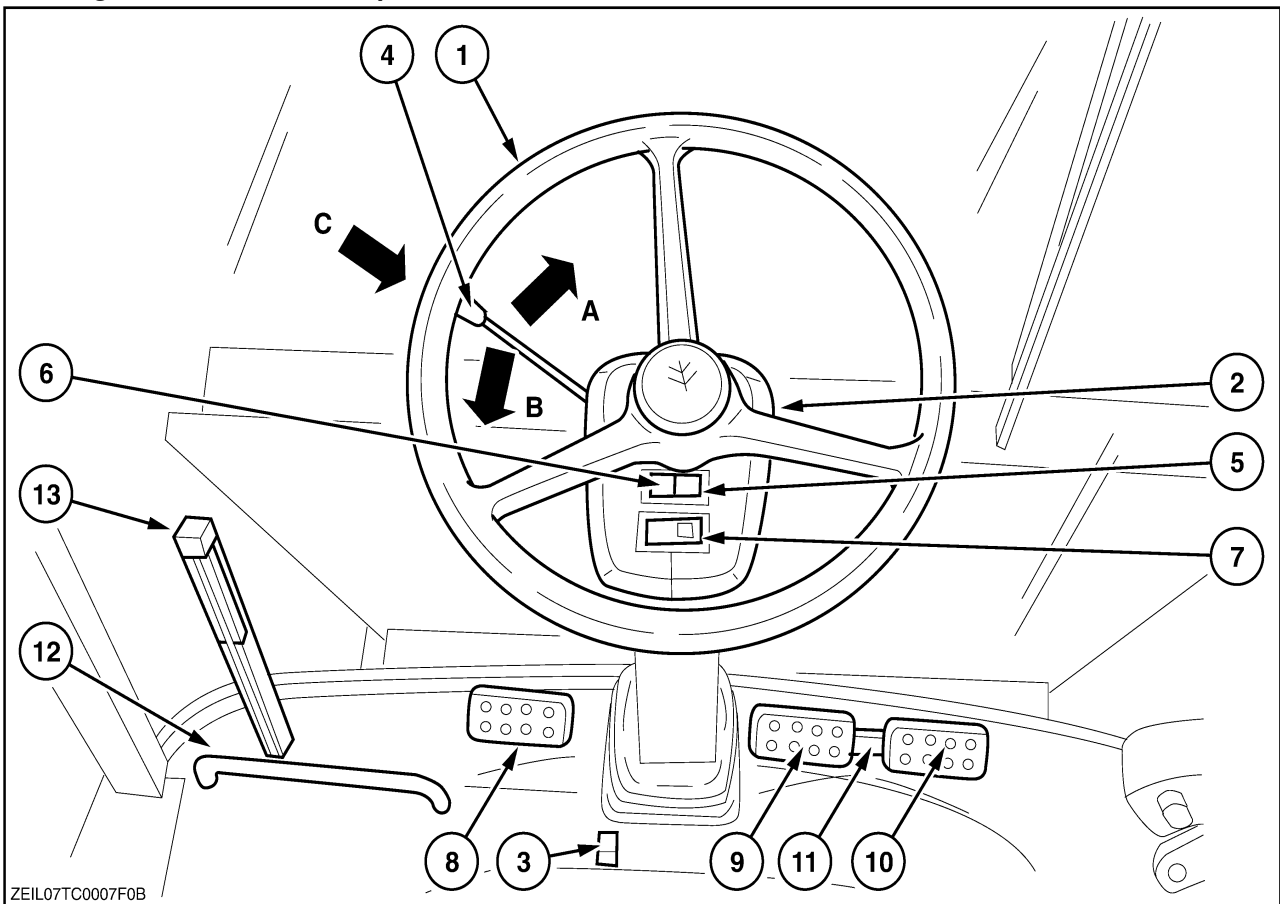

ZEIL07TC0007F0B

9

- 1. Steering wheel
- 2. Steering wheel tilt control (screw)
- 3. Steering column tilt control pedal
- 4. Direction indicator and horn
 - a: right-hand side
 - b: left-hand side
 - c: horn
- 5. Direction indicator warning light – combine
- 6. Highlights indicator light
- 7. Direction warning light – trailer
- 8. Clutch pedal (TC5040 - TC5060)
- 9. Foot brake pedal left-hand side

- 10. Foot brake pedal right-hand side
- 11. Brake pedals coupler

CAUTION

For safety reasons, always couple the brake pedals by means of the brake pedal coupler when driving on public roads. This ensures the brakes are actuated together.

- 12. Foot support (if installed)
- 13. Stubble height indicator (if applicable)

Right-hand module

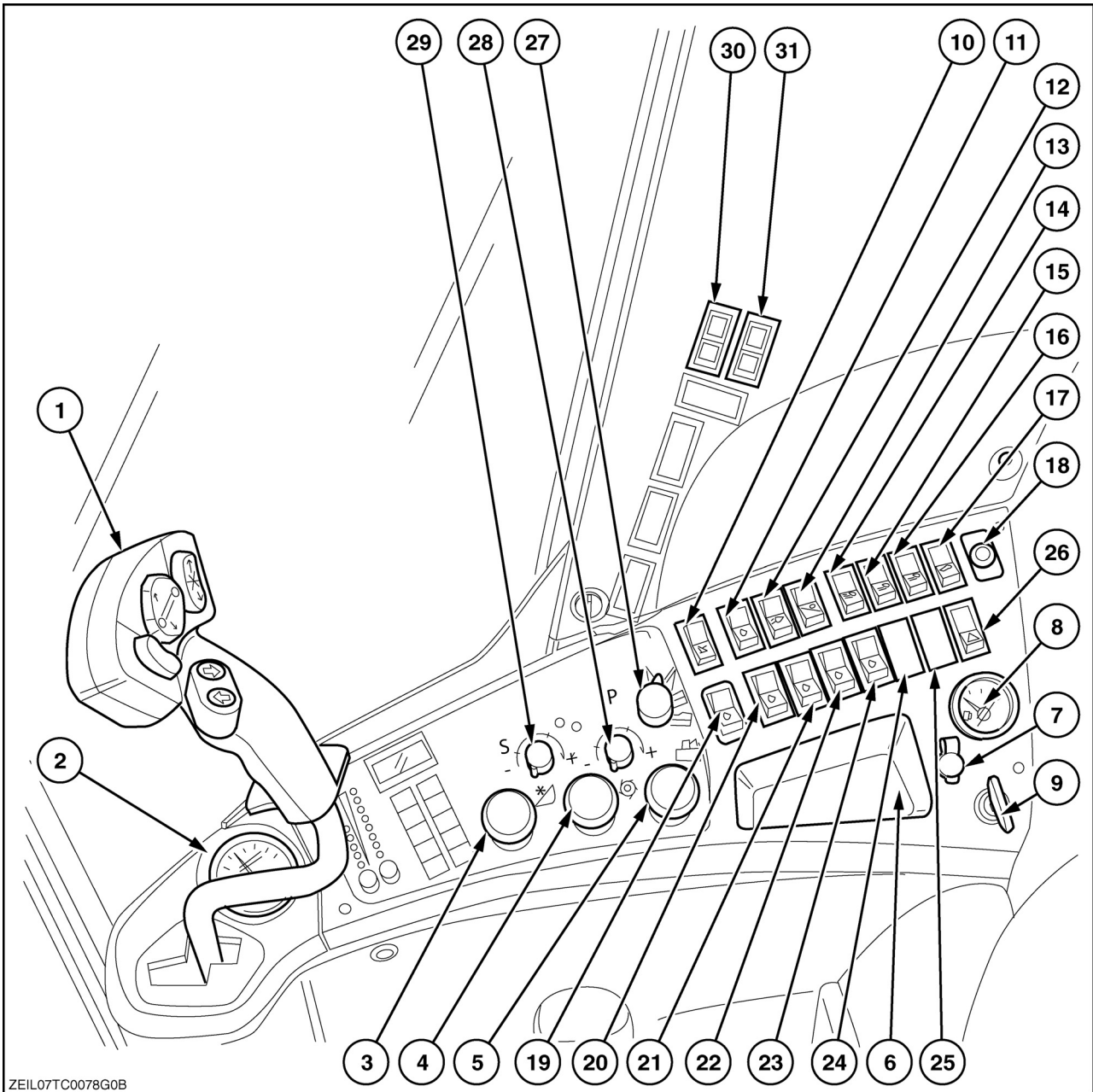

ZEIL07TC0078G0B

1. Multi-function handle (TC5050 – TC5070 – TC5080) (see further in this section for more detailed information)

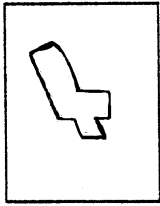

Forward



Neutral



Reverse

(and audible alarm)

1. Multi-function handle (TC5040 – TC5060) (see further in this section for more detailed information)

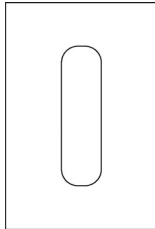

Increase ground speed



Neutral



Decrease ground speed

SECTION 2 – CONTROLS, INSTRUMENTS AND OPERATION

2. Header compensation gauge (see further in this section for more detailed information)

3. Header/ Straw elevator engagement switch (if applicable)

- To engage, push down on the spring-loaded orange cap and pull up the black ring under the orange cap.
- To disengage, press on the top of the orange cap.

NOTE: The header mechanism can only be engaged if field mode (with the Safety-on-the-road tumbler switch) is selected + threshing mechanism is engaged, and the operator's seat is used (if applicable).

4. Threshing mechanism engagement switch (if applicable)

- To engage, push down on the spring-loaded orange cap and pull up the black ring under the orange cap.
- To disengage, press on the top of the orange cap.

NOTE: The threshing mechanism can only be engaged if field mode (with the Safety-on-the-road tumbler switch) is selected, and the rear ladder is in the upper position.

5. Unloading tube engagement switch (if applicable)

- To engage, push down on the spring-loaded orange cap and pull up the black ring under the orange cap.
- To disengage, press on the top of the orange cap.

NOTE: The unload tube mechanism can only be engaged if field mode (with the Safety-on-the-road tumbler switch) is selected and the unload tube is in open position.

6. Storage place for small items

7. 12 Volts DC socket

8. Fuel gauge

9. Ignition key (ignition, engine start and stop key)



1. Off
2. Not used
3. Contact
4. Engine starter motor

NOTE: When set the ignition key in "contact" position, an audible signal will sound, a lamp test and the revolving flash lights will be activated for a few seconds.

10.

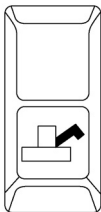

Unloading tube swing tumbler switch

- Unloading tube swing out
- Neutral
- Unloading tube swing in

11.

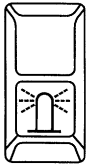

Revolving flash light(s) tumbler switch (If installed)

- Position 1: Revolving flash light(s) activated during 7 seconds when grain tank high level indication
- Position 2: Revolving flash light(s) activated as long as grain tank high level indication
- Position 3: On-road situation (always on)

12.

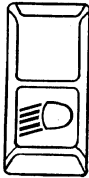

Traffic lights tumbler switch

- Off
- Position 1: Parking lights
- Position 2: Headlights

13.



Headlights tumbler switch

(only when traffic lights tumbler switch is ON in position 2)

- Off
- On

14.



Worklights tumbler switch

- Middle+central+outer worklights (left-hand position "2") and rear worklights (if field mode is selected)
- Central and outer worklights (middle position "1")
- OFF (right-hand position "0")

SECTION 2 – CONTROLS, INSTRUMENTS AND OPERATION

15.



Stubble + rear lights tumbler switch (if installed), (if field mode is selected and work lights are on)

- Off
- On

16.



Cab operating lights tumbler switch (If installed)

- Off
- On



WARNING



Avoid disturbing road users with the headlights switched on.

17.



Unloading tube light tumbler switch (only when work lights are On)

- Off
- On

18.



Mirror adjustment switch (If installed)

- Arrow to the left: left-hand mirror
- Arrow to the right: right-hand mirror

19.



Engine throttle rocker switch (only TC5070 and TC5080)

- Increase engine speed
- Neutral
- Decrease engine speed

The engine rpm will automatically increase or decrease with one single pulse. Press the opposite part of the switch to stop the automatic (increase/decrease) engine rpm.

NOTE: The engine rpm can only be increased minimum 5 seconds after the engine has been started.

20.

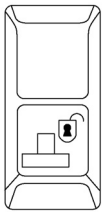

Safety-on-the-road tumbler switch

- Field mode
- Road mode

The following main functions will be disabled in road mode:

- Automatic header height control
- Reel speed adjustment + synchronisation
- Header engagement, reversing (if remote control)
- Threshing engagement (if remote control)
- Unload tube open/close (if remote control) + unload engagement
- Stubble + rear lights
- Straw chopper (if remote control)

SECTION 2 – CONTROLS, INSTRUMENTS AND OPERATION

21.

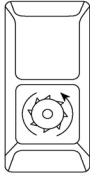

Drum speed rocker switch (*)

- Increase drum speed
- Neutral
- Decrease drum speed

22.

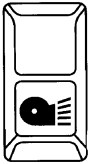

Fan speed rocker switch (*)

- Increase fan speed
- Neutral
- Decrease fan speed

23.

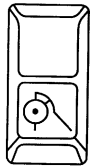

Straw chopper engagement tumbler switch (*)

- Off
- On

24.

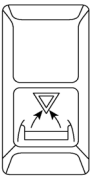

Self-levelling rocker reset switch (if installed) (*)

- Off
- On

25. Spare

26.



Hazard warning lights tumbler switch

- Off
- On

(*): If threshing mechanism is engaged

SECTION 2 – CONTROLS, INSTRUMENTS AND OPERATION

27.

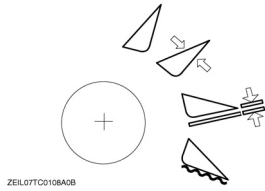

Header control selector switch.

- Transport mode
- Compensation mode
- Stubble height mode
- Autofloat™ mode or Controlfloat™ mode

28.

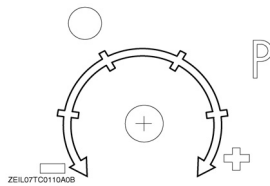

Header compensation control knob

- “+”: To increase the pressure of the header onto the soil
- “-”: To decrease the pressure of the header onto the soil

29.

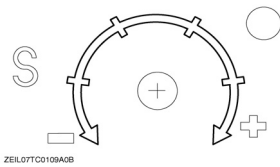

Header stubble height control knob

- “+”: To increase the preselected stubble height
- “-”: To reduce the preselected stubble height

30.

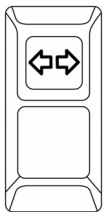

Chopper spreader plates rocker switch (if installed) (*)

- Towards left-hand side

31.

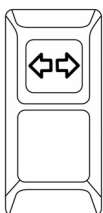

Chopper spreader plates rocker switch (if installed) (*)

- Towards right-hand side

(*): If threshing mechanism is engaged

Alarm control module

The alarm control module is located in the right-hand module. For details, see below.

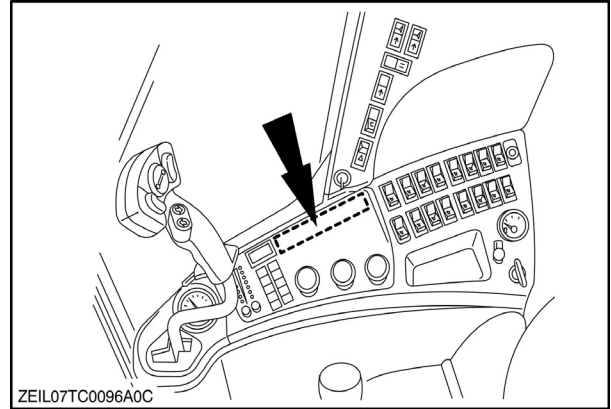

11

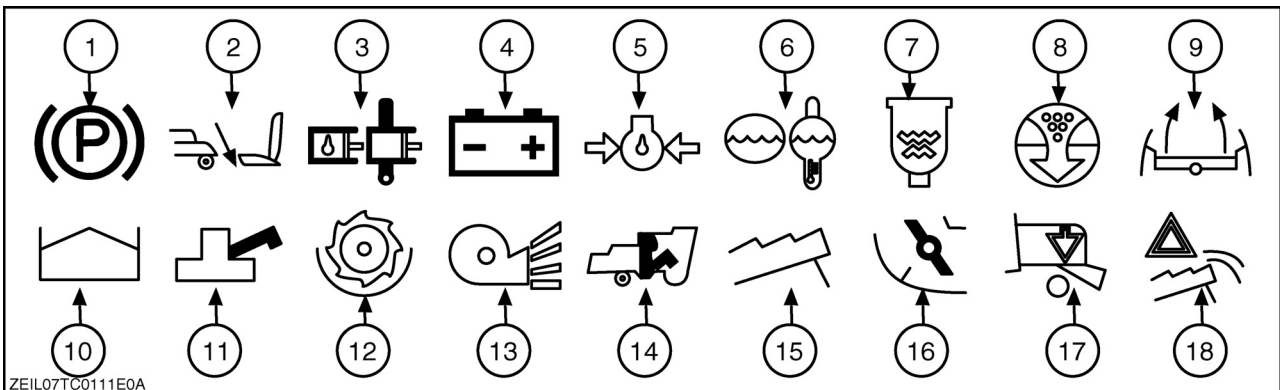

12

1. Parking brake alarm
2. Engine rear ladder or operator's seat alarm
3. Hydrostatic low pressure or temperature alarm
4. Battery charge alarm
5. Engine low oil pressure alarm
6. Coolant temperature or shunt tank alarm
7. Water in fuel
8. Air restriction alarm
9. Self-levelling alarm
10. Full grain tank alarm
11. Open unloading tube alarm

In road mode: Alarm led is flashing + buzzer for 3 seconds

In field mode: Alarm led is continuous activated

If ground speed > 15 km/h for minimum two seconds: Alarm led is flashing + buzzer for 10 seconds

12. Drum speed alarm
13. Fan speed alarm
14. Return elevator speed alarm
15. Straw walker speed alarm
16. Straw chopper speed alarm
17. Swath plate position alarm
18. Straw walker blockage alarm

Multi-function handle

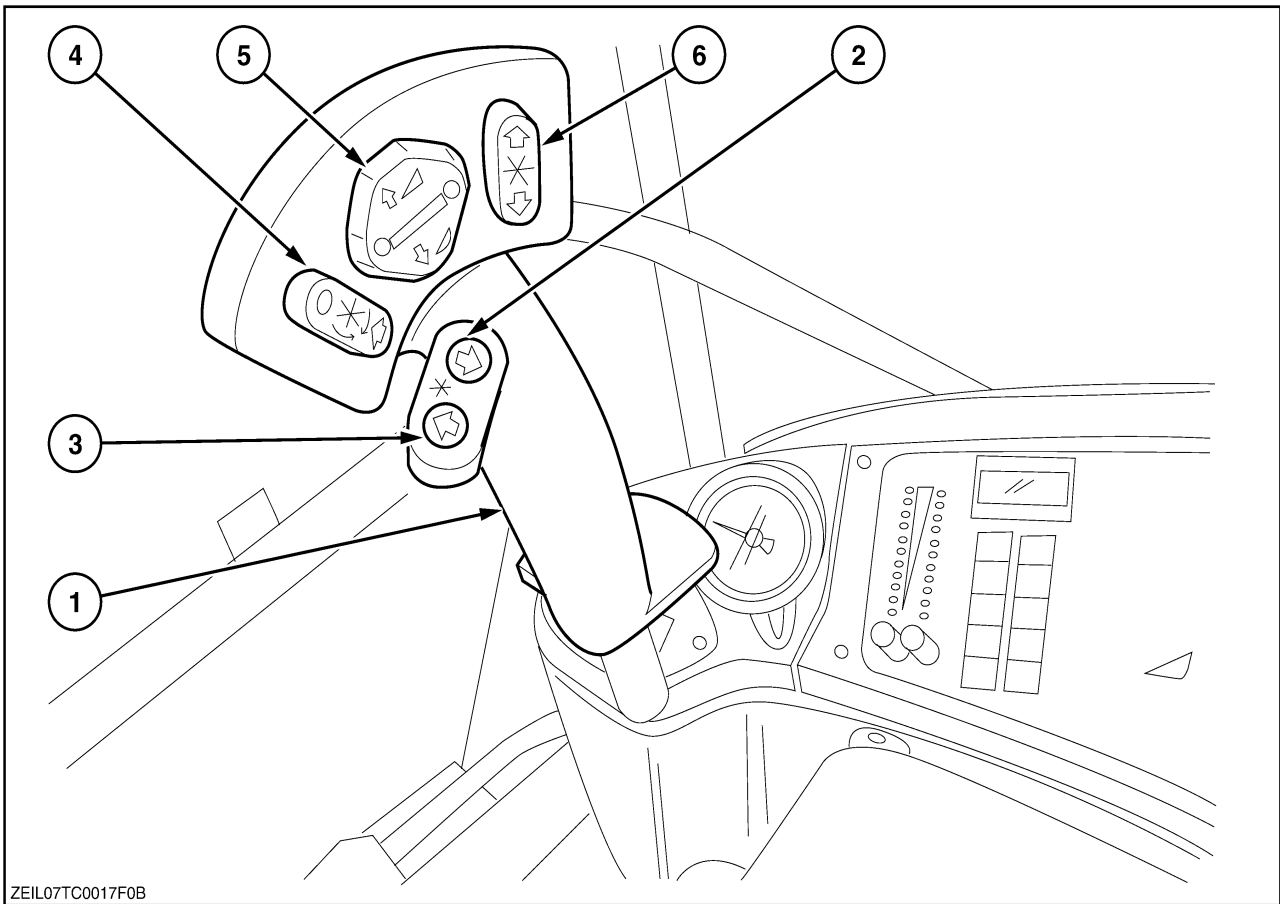

ZEIL07TC0017F0B

13

1. Multifunction handle
2. Reel fore adjustment
3. Reel speed increase/decrease rocker switch
up = speed increase
down = speed decrease
4. Reel after adjustment
5. Header height control and header flotation
(if applicable) rocker switch

6. Reel height control rocker switch

NOTE: In case a maize header is attached:
Up = stripper plates open
Down = stripper plates closed

With the upper and lower part of this switch, the header can be moved up and down respectively. In case of header height control, the header height switch offers two speeds. Pushing the switch to its first stop, both up and down, the movement will be slow. When pushed to the second stop, the up and down movement will be fast.

If lateral float, with the left and right part of the switch, the lateral float of the header can be adjusted. Pushing to the left will tilt the header counter-clockwise, pushing to the right will tilt the header clockwise.

- 7. Resume button (if header height control)
- 8. Header and straw elevator reversing button

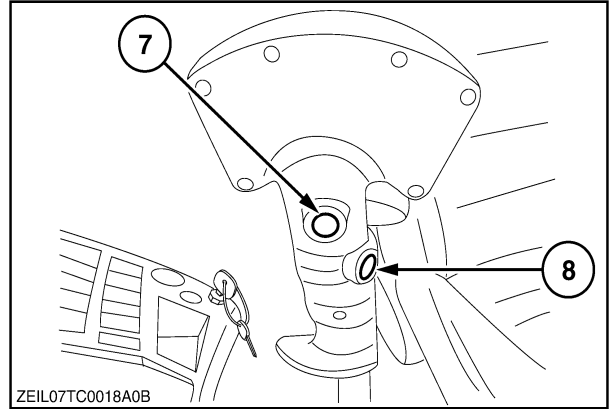

Cab roof controls

1. Heating switch (if installed)
2. A/C system switch (if cab)
3. Fan switch (3 speeds)
4. Screen washer rocker switch (if installed)
5. Windscreen wiper switch (2 speeds)
6. Radio location

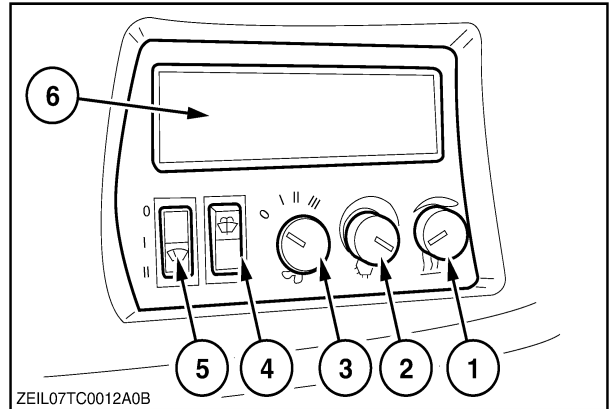

15

7. Air vents
8. Cab roof lock
To release the cab roof, pull the handle down.

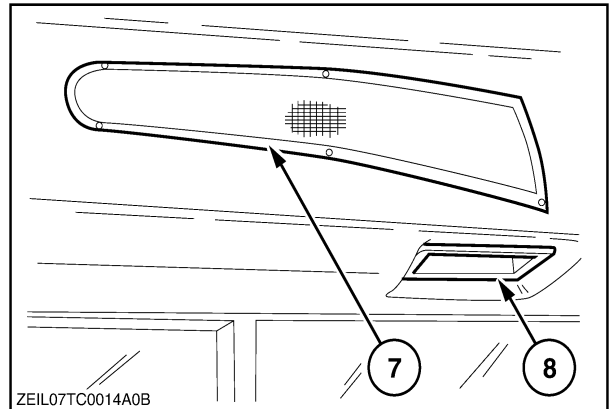

16

9. Adjustable air vents

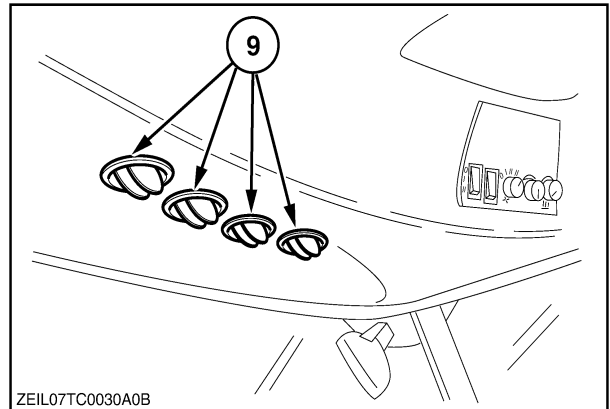

17

10. Speaker location

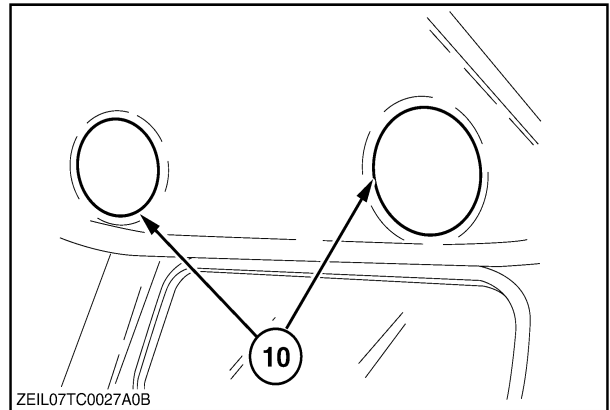

18

11. Cab interior light

There are three positions:

- OFF
- MIDDLE
- ON

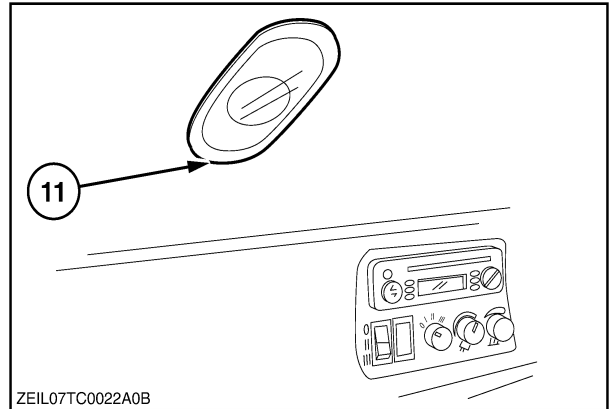

19

Lighting and mirrors

- Without cab

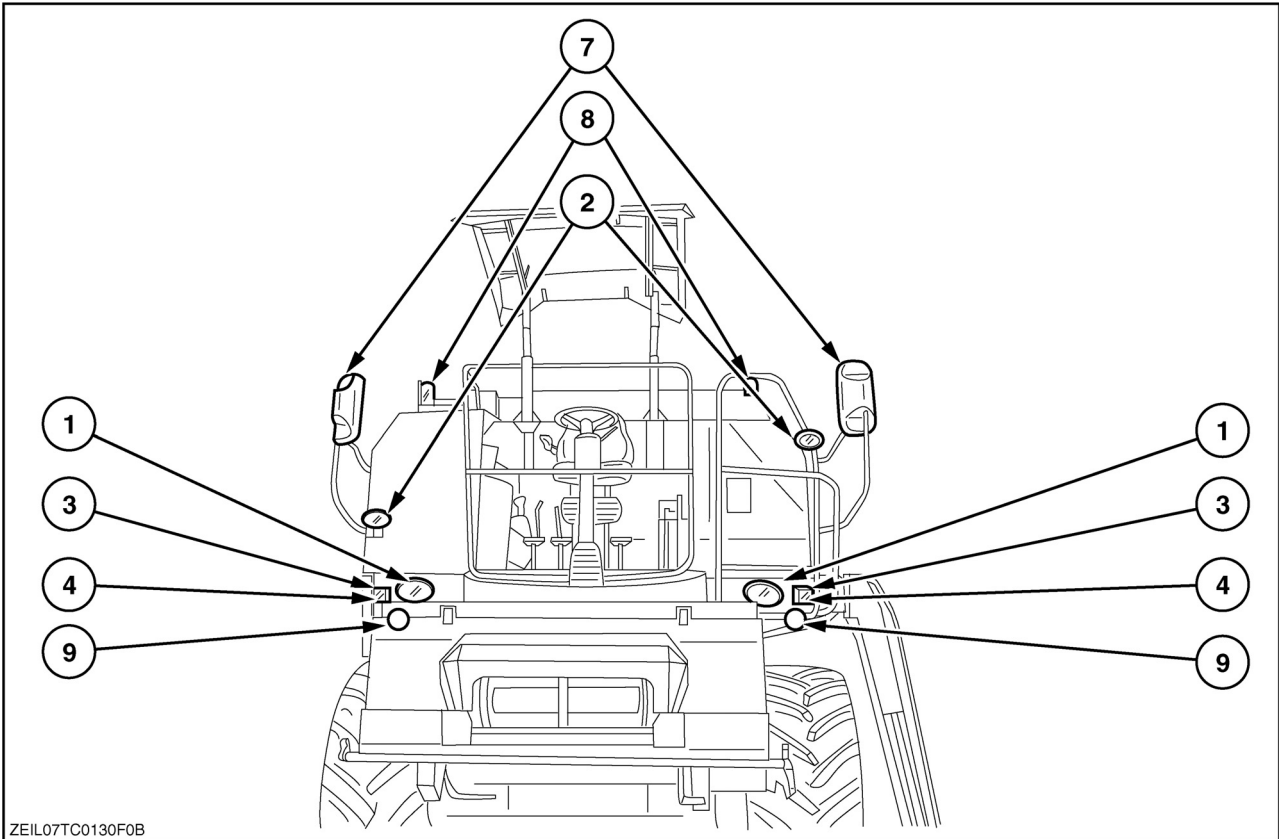

ZEIL07TC0130F0B

20

1. Dimmed lights and Headlights
2. Work lights
3. Direction indicators
4. Parking lights
5. -

6. -
7. Electrical adjustable mirrors
8. Revolving flash lights
9. Stubble lights (if installed)

■ • With cab

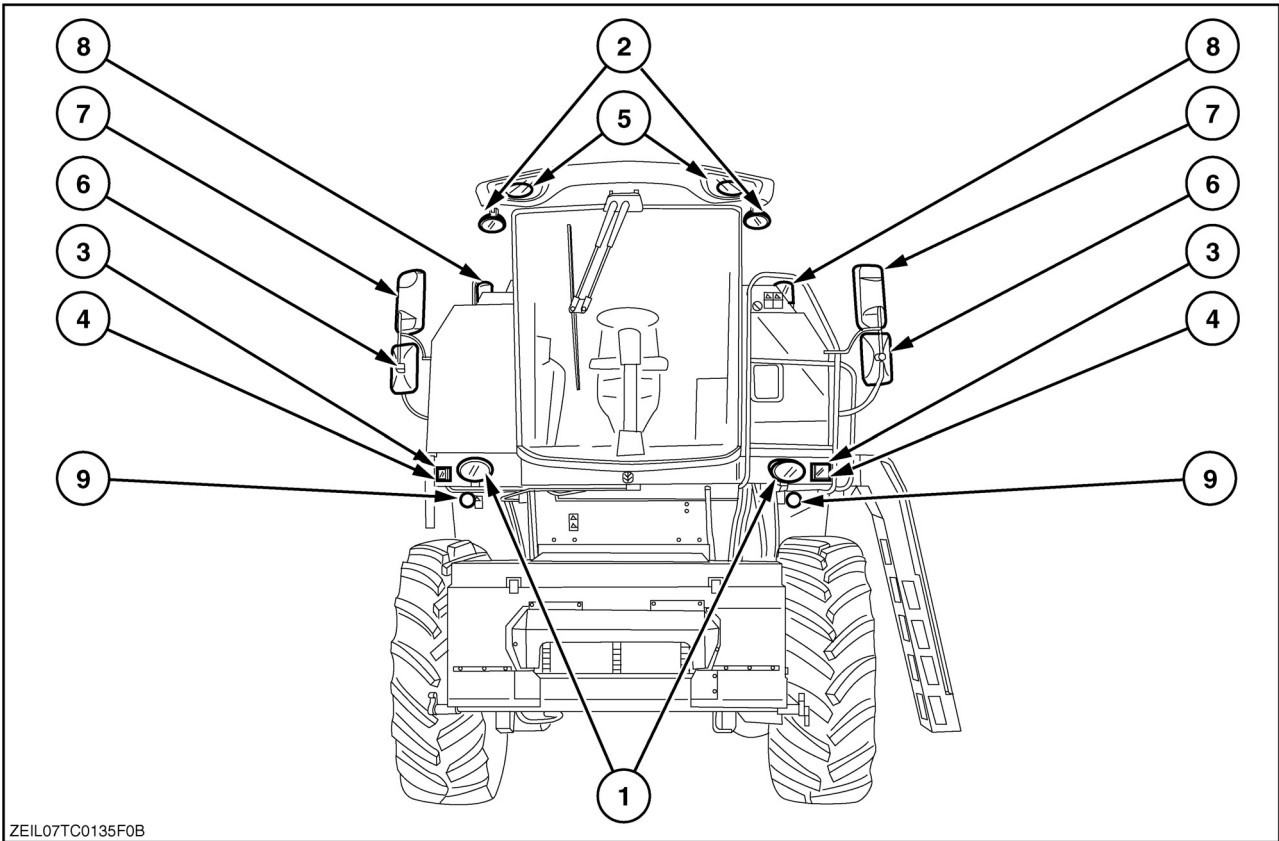

ZEIL07TC0135F0B

21

- | | |
|-----------------------------------|----------------------------------|
| ■ 1. Dimmed lights and Headlights | ■ 6. Main adjustable mirrors |
| 2. Work lights | 7. Electrical adjustable mirrors |
| 3. Direction indicators | 8. Revolving flash lights |
| 4. Parking lights | 9. Stubble lights (if installed) |
| 5. Cab operating lights | |

SECTION 2 – CONTROLS, INSTRUMENTS AND OPERATION

1. Stop lights
2. Rear road lights
3. Direction indicator
4. Rear work lights (if installed)

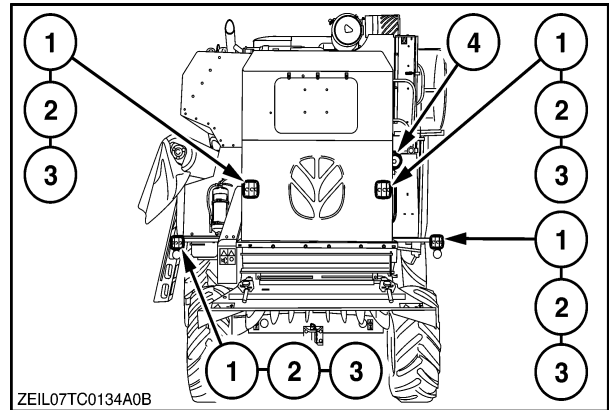

22

5. Unloading tube light (if installed)

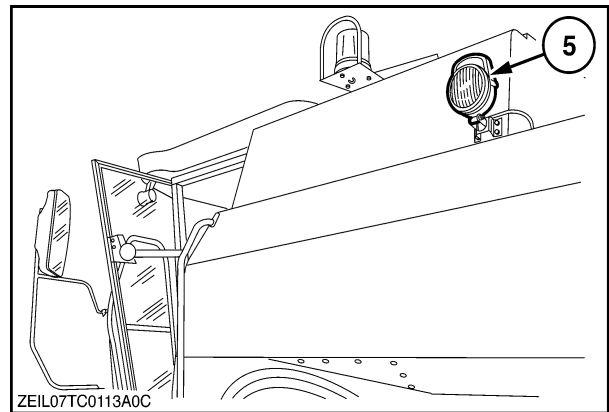

23

6. Grain tank light

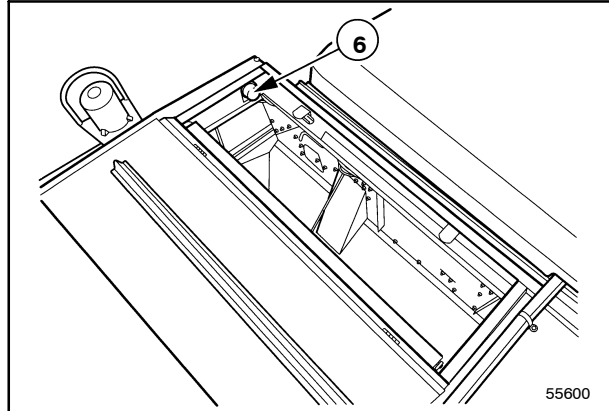

24

7. Portable light

One at the left and one at the right-hand side

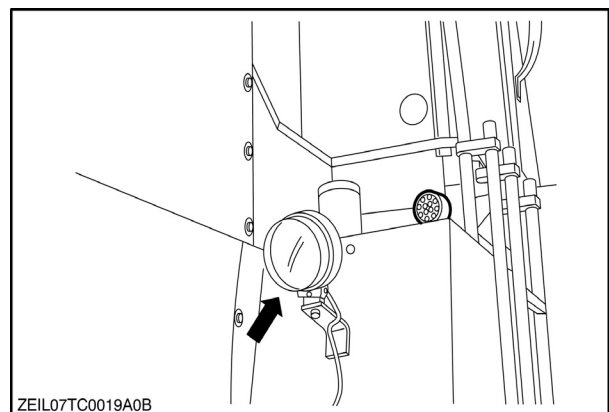

25

RIGHT-HAND SIDE COMPONENTS

1. Cleaning fan speed control lever (mechanical) (only TC5040 – if applicable)

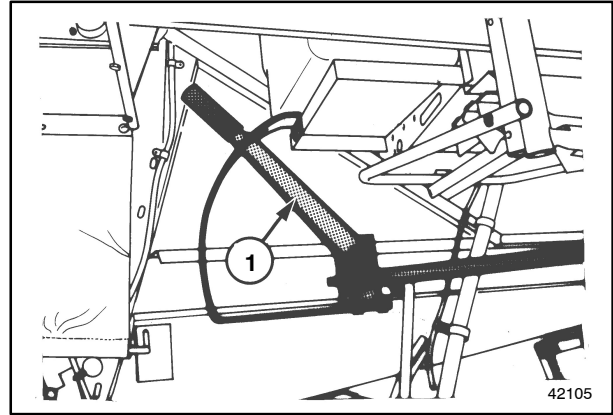

26

2. Self-levelling cleaning system override switch [if installed].
This switch allows easier installation of the upper sieve (see Section 3 – FIELD AND SITE OPERATION).

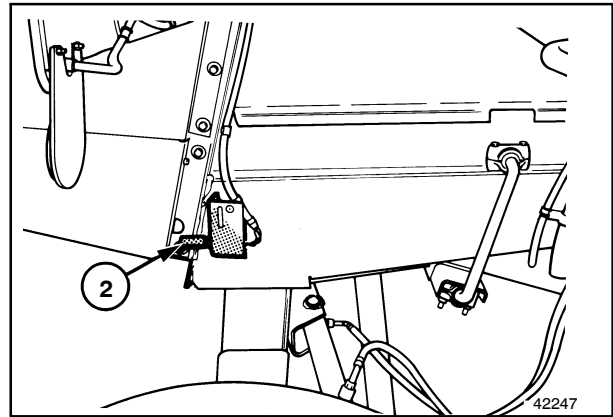

27

3. Drum socket wrench
When the drum is in blocked, it can be released using this wrench (see Section 3 – FIELD AND SITE OPERATION).

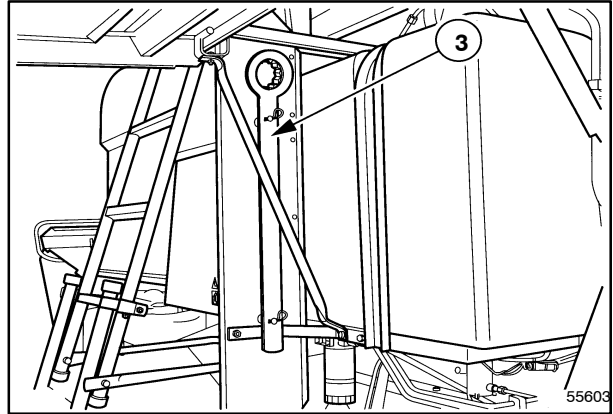

28

LEFT-HAND SIDE COMPONENTS

1. Special tool to open secured shielding and to ease the header drive shaft coupling.

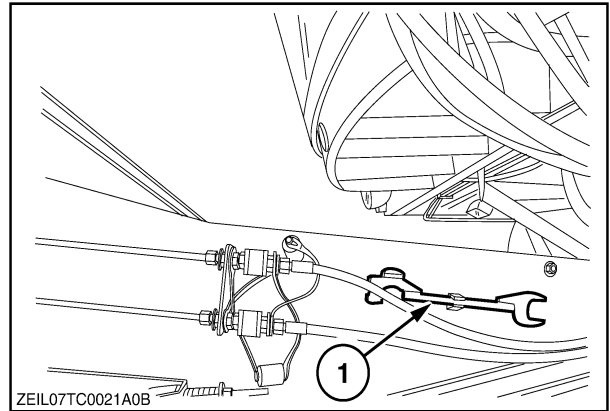

29

2. Grain tank inspection door

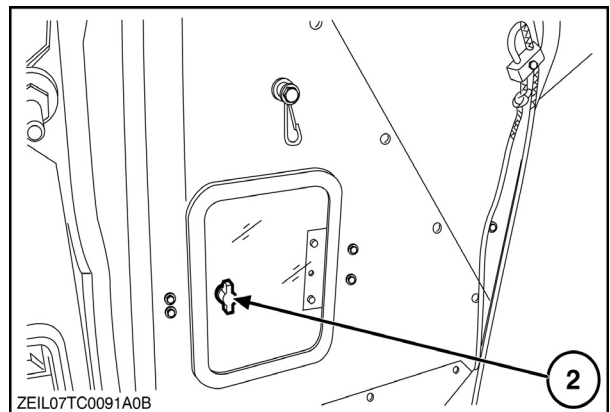

30

SECTION 2 – CONTROLS, INSTRUMENTS AND OPERATION

3. Battery key
Turn the key counter clockwise 1/4 turn after having switched off the ignition key.
Turn the key clockwise 1/4 turn before switching on the ignition key in the cab.

IMPORTANT: To avoid loss of data and/or monitor damage, it is strongly recommended not to stop the engine by using the battery switch. Always use the contact key in this case and wait for minimum 15 seconds before disconnect the battery switch.

IMPORTANT: It is advisable to disconnect the batteries at the end of the day, using the battery switch.

4. Batteries
Remove the rubber cover to have access to the batteries.
5. Toolbox

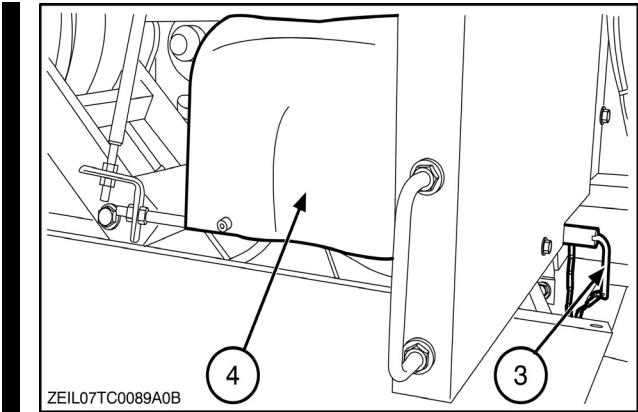

31

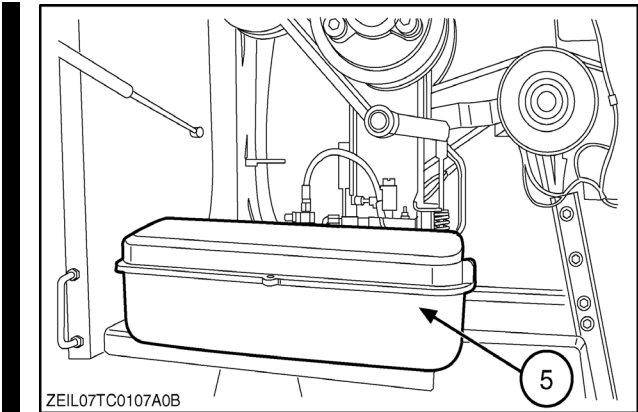

32

OTHER COMPONENTS

- Diagnostic port for off-board or diagnose and software download. (CAN module)

Located in the fuse and relay box at the right-hand side of the cab.

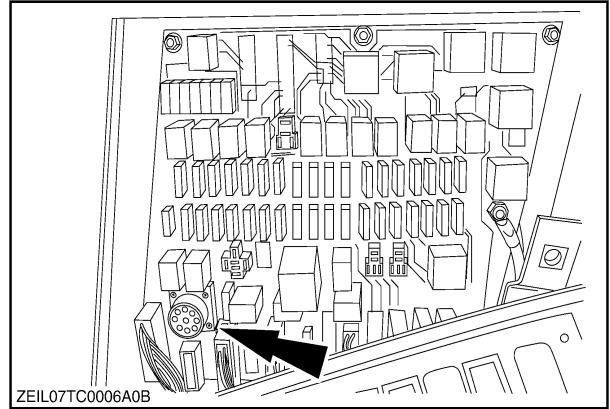

33

- 12-Volt DC socket (left)

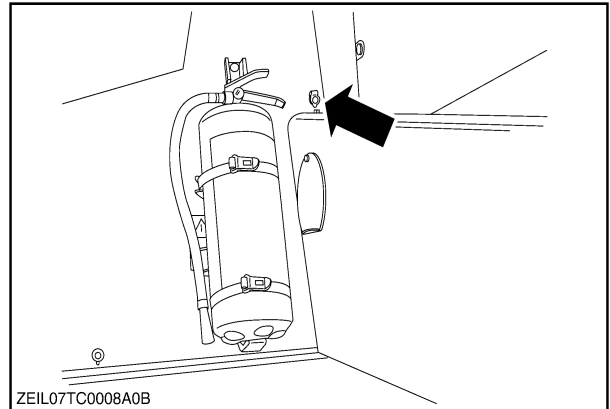

34

PERFORMANCE MONITOR (IF INSTALLED)

The performance monitor allows you to operate at the highest speed with a minimum of grain loss. The grain loss is measured at the end of the sieves and at the end of the straw walkers.

1. Indicator light bar of straw walker grain losses
2. Sensitivity knob for straw walker grain loss sensor
3. Indicator light bar of sieve grain losses
4. Sensitivity knob for sieve grain loss sensor

The indicator light bars (1) and (3) comprise four green lights at the bottom, followed by three yellow lights and finally three red lights on top. The first green light is on at all times, regardless of loss or monitor setting. As the loss signal rate increases, more lights will glow.

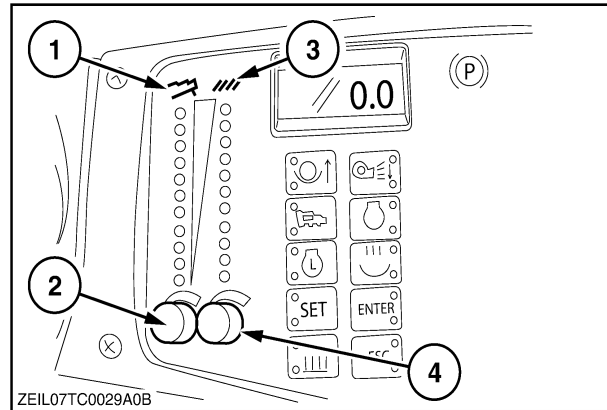

As the grain loss measuring is not an absolute but a relative measuring, proceed as follows to set the performance monitor:

1. Engage the header drive.
2. Engage the first or the second gear and enter the crop.
3. Adjust the reel height, the reel fore and after setting and the reel speed, according to the type of crop being harvested.
4. Adjust the forward speed with the ground speed control lever. The ground speed in km/h can be observed on the tachometer.
5. Stop the machine after a hundred metres and take a grain sample. Check also for grain losses in the swath. If the result unsatisfactory, carry out the necessary adjustments.
6. Select the highest ground speed consistent with obtaining good results.
7. Set the sensitivity knob (4) of the sieves sensor so that all green lights and one yellow light on the indicator light bar (3) appear.
8. Set the sensitivity knob (2) of the straw walker sensor so that all green lights and one yellow light on the indicator light bar (1) appear.
9. Increase the forward speed until one of the bars (1) or (3) glows into the red zone.

Stop the machine and check if grain losses has clearly increased. If not, this means that the sensitivity of the bar with the most lights on, was set too high. Set the sensitivity knob corresponding with this bar so that it glows on a lower level (only two or three green lights) at the speed selected under point 6.

- If the rate of loss increases, more lights will illuminate.
- If the rate decreases, lights will extinguish.

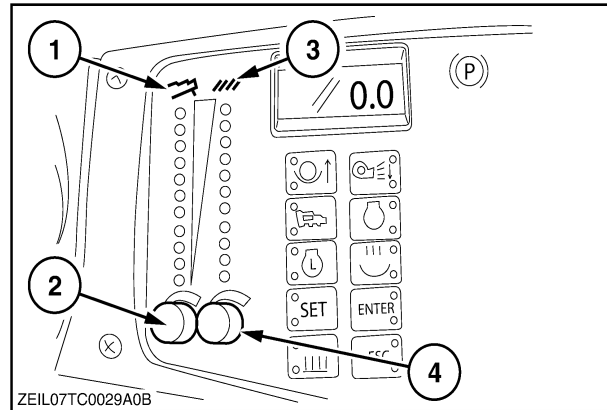

Display with keyboard functions

1. 4-digit display
 2. Drum speed selector button
press once: Drum speed (led is on)

press twice: Threshing hours (led is flashing)
 3. Cleaning fan selector button
 4. Ground speed selector button
 5. Engine speed selector button
press once: Engine speed (led is on) and also default on display during 4 seconds when throttle is increased or decreased.

press twice: Engine hours visible on the display during 10 seconds (led is flashing).

press three times: Coolant temperature visible on the display during 10 seconds (led is flashing fast)
 6. press once: Engine load selector button (only if TC5070 – TC5080)
press twice: Fuel temperature
 7. Partial / Stored / Total area selector button
press once: Partial area (ha or acres)

press twice: Stored area (ha or acres)

press three times: Total area (ha or acres)
 8. Monitor settings (led is on)
 9. Enter button
 10. Header width correction button
The header width can be reduced (only with the header down) in steps of one fourth of the total header width in case of a grain header, one row in case of a maize header every time the button is pushed. (During a 10 seconds period) A short beep confirmed the reduction.
- NOTE:** Each time the area counter is stopped (by rising the header) the full header width is restored. The display shows: "- - -".
11. Escape button
Escape in Set mode/ alarm mode
Kill stall and override

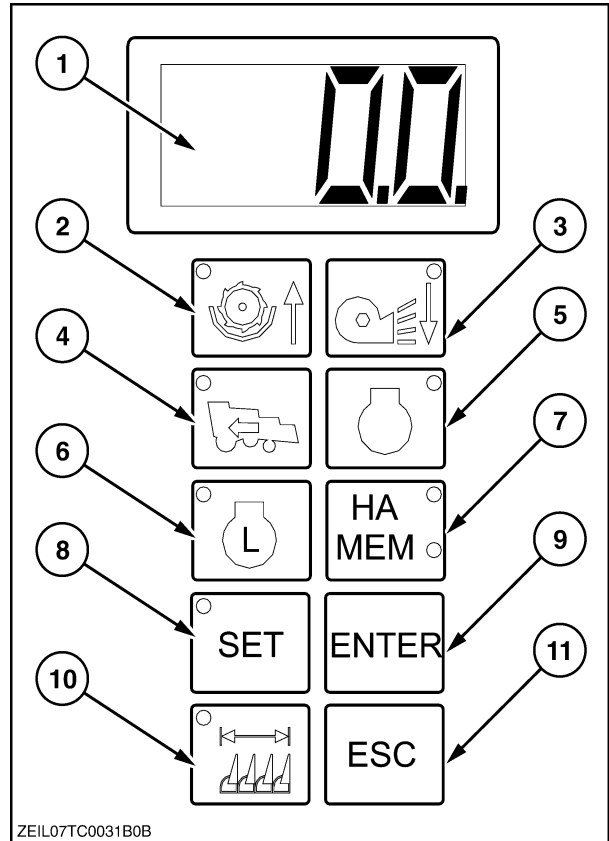

MONITOR SETTINGS

To achieve a correct working and/ or read out of some functions the following header and combine settings have to be done.

1. Full header width
2. Ground speed constant adjustment
3. Straw chopper availability
4. Metric/ Imperial setting

IMPORTANT:

- To change the settings, press on the “SET” button.
- Leave the settings by pressing on the “ESC” button during 5 seconds.

1. Full header width

The full header width represents the header width of the current used header.

The grain headers are expressed in **feet**, the maize headers are expressed in row **number** and row **distance** (cm).

This value is important for:

- Area calculation

NOTE: If a maize header is selected the Autofloat™ system will be disabled.

To select this mode, proceed as follows:

1. Set the ignition key in the contact position.
2. Press on the “SET” button (8).
3. On the display (1) appears the width in the following format:
 “ft ZZ” = grain header width in feet. (blinking)
 or
 “YY:XX” = “YY” = row number (blinking)
 “XX” = row distance in cm
4. Press the “ARROW UP” (2) or the “ARROW DOWN” button (3) to select your used header. The value can be changed between:
 10 and 25 ft for grain header width
 4 and 12 for row number
 50 and 100 for row distance in cm
5. Press the “ENTER” button (9) for minimum two seconds to validate. The validation is confirmed by a short beep and the routine jumps to the next value or mode.

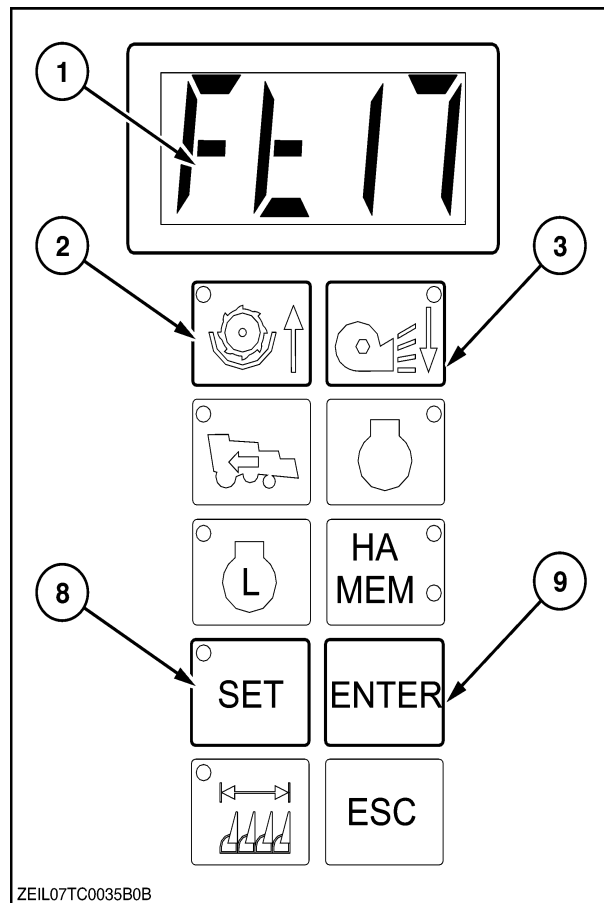

ZEIL07TC0035B0B

2. Ground speed constant adjustment

The ground speed constant is a value needed for the ground speed calculation. This value depends of the tyre load radius and the final drive reduction.

To select this mode, proceed as follows:

1. Set the ignition key in the contact position.
2. Press on the “SET” button (8).
3. Press on the “ESC” button (11) (1 time) until the led of the “GROUND SPEED” button (4) is blinking.
On the display (1) appears the current ground speed constant value “XXXX”.
4. Press the “ARROW UP” (2) or the “ARROW DOWN” button (3) to change the current ground speed constant value on the display (1).
The value can be changed between 1000 and 9900 in steps of 5.
5. Press the “ENTER” button (9) for minimum two seconds to validate.
The validation is confirmed by a short beep and the routine jumps to the next mode.

NOTE: The number of the ground speed constant can be find in the table below.

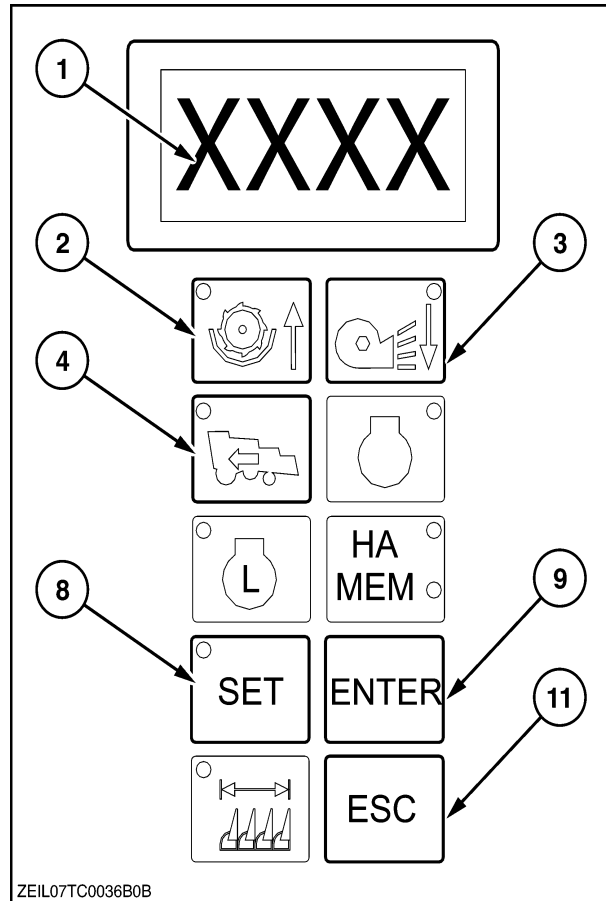

39

Traction tyre	Ground speed constant				
	TC5040	TC5050	TC5060	TC5070	TC5080
23.1-26-10PR-SSG (37)		1335		1819	
23.1-26-14PR-AN15(37)STOMIL		1355		1847	
620/75R26-166A8(37)		1365		1862	
620/75R30-163A8-DT820		1278		1745	
650/75R32-172A8-DT820		-			1638
750/65R26-166A8(57)		1353		1847	
800/65R32-172A8(100)		-			1638

NOTE: This can also be done via an automatic calibration, refer to “Automatic ground speed calibration”, further in this section.

Automatic ground speed calibration

With this routine the ground speed constant can also be defined.

Proceed as follows:

1. Mark a distance of 100 m to be driven on a straight road.
2. Position the combine at the 0 m mark.
3. Press and hold the “SET” button (8) during 5 seconds. The display (1) will show “AUtO”.
4. Start driving the combine. “AUtO” will be flashing as soon the ground speed pulses are detected.
5. At the 100 m mark, press and release the “SET” button (8) again.
A new ground speed constant will be calculated and will be displayed for 2 seconds.
6. Calibration is done and the display will revert to the normal display.

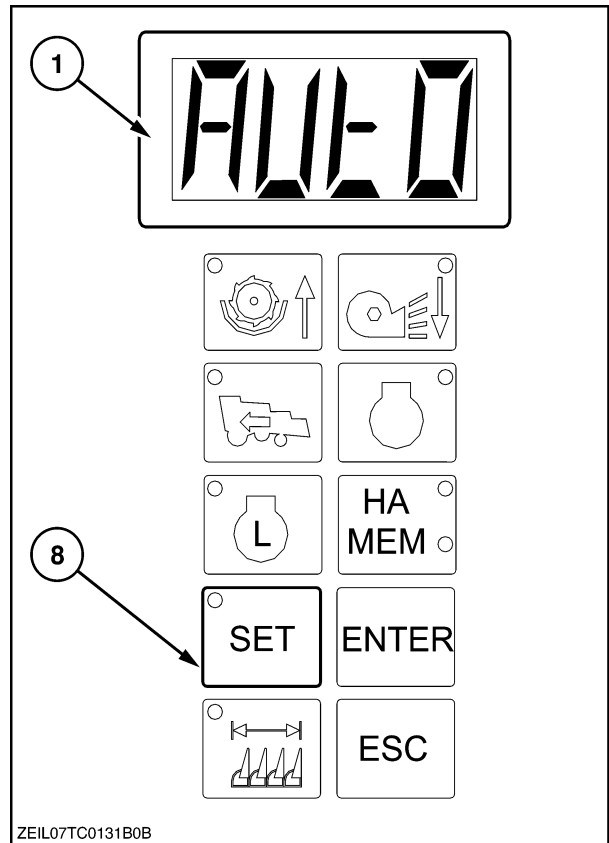

3. Straw chopper availability

In this mode, the operator can define if a straw chopper is installed or not.

NOTE: This setting prevent false shaft speed alarm or swath plate position alarm by absence of a straw chopper.

To select this mode, proceed as follows:

1. Set the ignition key in the contact position.
2. Press on the “SET” button (8).
3. Press on the “ESC” button (11) (2 times) until on the display (1) appears:
 “CH_0” = Chopper not installed
 or
 “CH_1” = Chopper installed
4. Press the “ARROW UP” (2) or the “ARROW DOWN” button (3) to make your choice between “CH_1” and “CH_0”.
 On the display (1) appears: “CH_1” or “CH_0”.
5. Press the “ENTER” button (9) for minimum two seconds to validate.
 The validation is confirmed by a short beep and the routine jumps to the next mode.

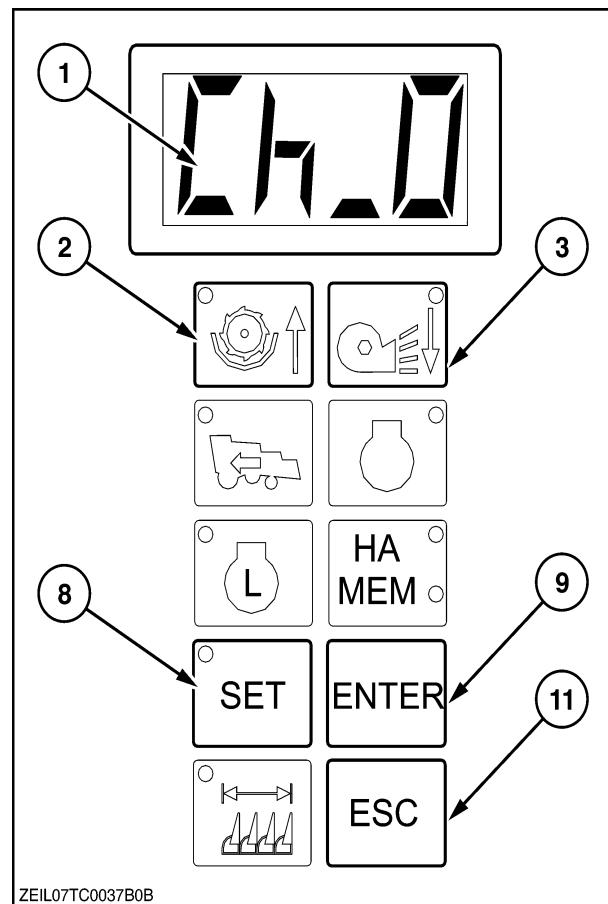

4. Metric / Imperial setting

In this mode the operator can choose between **metric** or **imperial** units.

The area calculation and the ground speed calculation make use of it.

To select this mode, proceed as follows:

1. Set the ignition key in the contact position.
2. Press on the “SET” button (8).
3. Press on the “ESC” button (11) (3 times) until on the display appears:
 “HA” = Hectare, km/h (metric)
 or
 “AC” = Acres, miles/h (imperial)
4. Press the “ARROW UP” (2) or the “ARROW DOWN” button (3) to make your choice between Metric or Imperial.
 On the display (1) appears “HA” or “AC”.
5. Press the “ENTER” button (9) for minimum two seconds to validate.
 The validation is confirmed by a short beep and the routine jumps to the next mode.
6. Leave the settings by pressing on the “ESC” button during 5 seconds.

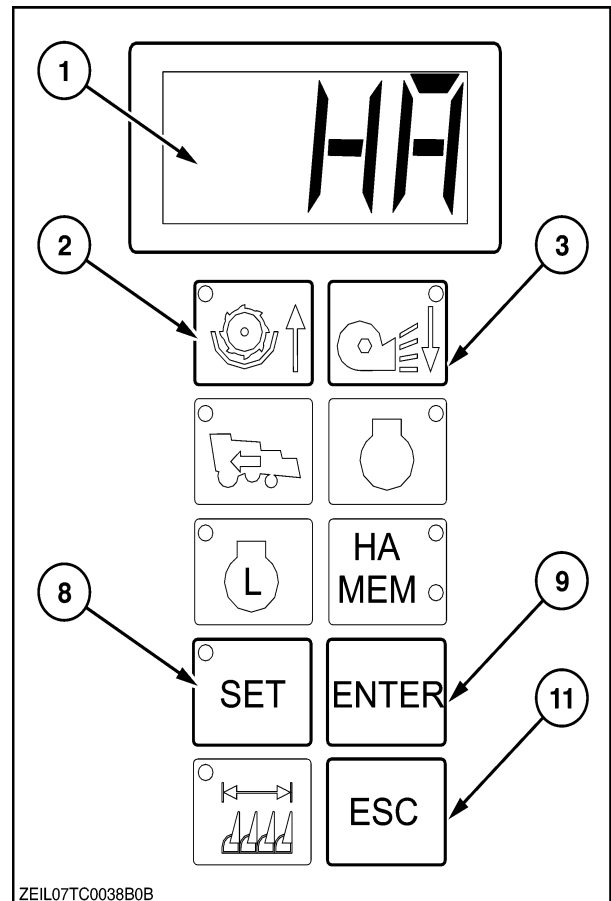

AREA COUNTER

Area indication

The area calculation is based on the following parameters:

- Ground speed value
- Header width

The area calculation starts under the following conditions:

- If threshing mechanism and header is engaged.
- If working **under** the maximum stubble height calibration.
(Refer to headed: “1. Maximum stubble height” of this paragraph)

Three different area values can be set on the display.

1. **Partial area:** The area accumulated at the moment.
2. **Stored area:** The current area stored into the memory (one memory is available)
3. **Total area:** The total area the machine has accumulated.

1. Partial area

Press the button (7) **once** to set the partial area on the display (1) in Ha or Acres depending of the monitor settings.

Refer to heading: “4. Metric / Imperial setting“ of this paragraph.

The corresponding led (12) is on.

NOTE: After pressing the button (7), the partial area is visible on the display (1) during 10 seconds, then the display will revert to the former function.

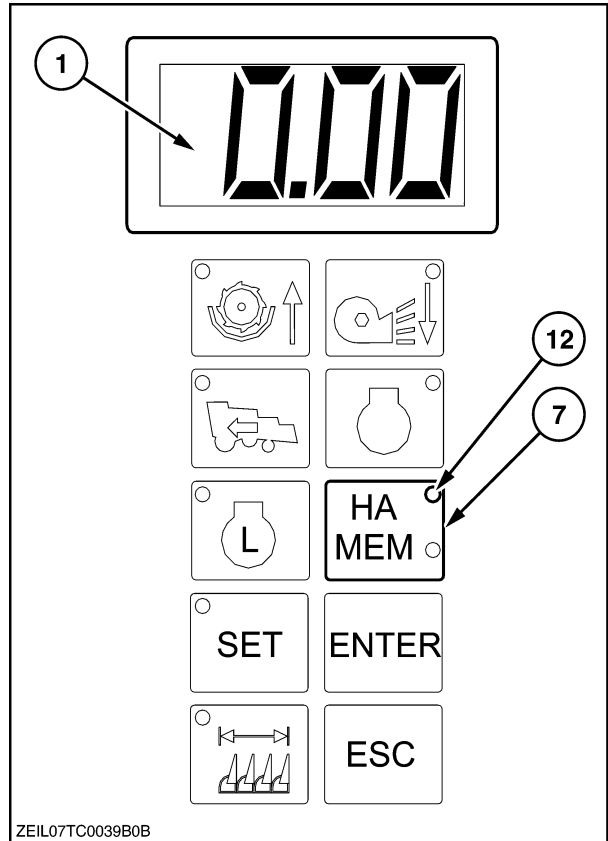

43

2. Stored area

Press the button (7) **twice** to set the stored area on the display (1) in Ha or Acres.

The corresponding led (13) is on.

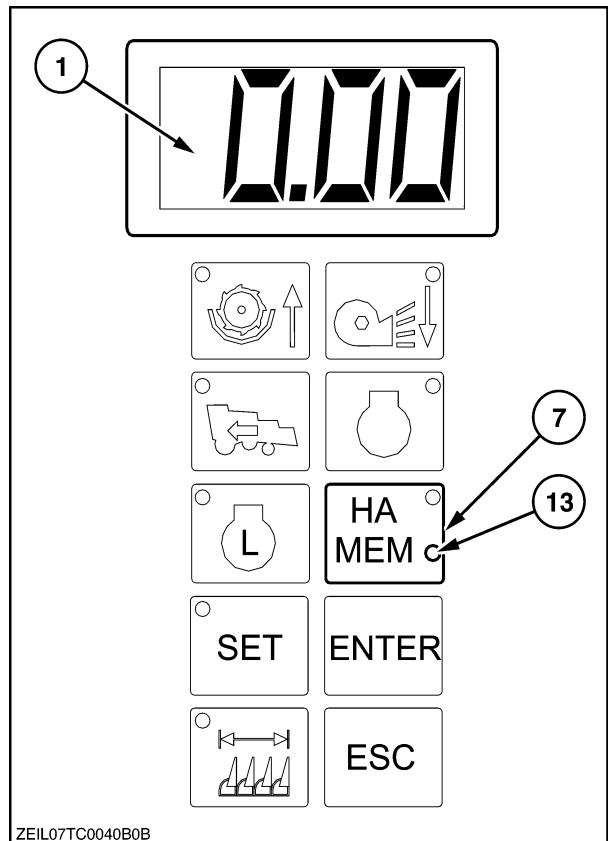

44

3. Total area

Press the button (7) **three** times to set the total area on the display (1) in Ha or Acres.
Both leds (12) and (13) are on.

NOTE: The total area can not be set to zero.

NOTE: After press the button (7), the partial area is visible on the display (1) during 10 seconds, then the display will revert to the former function.

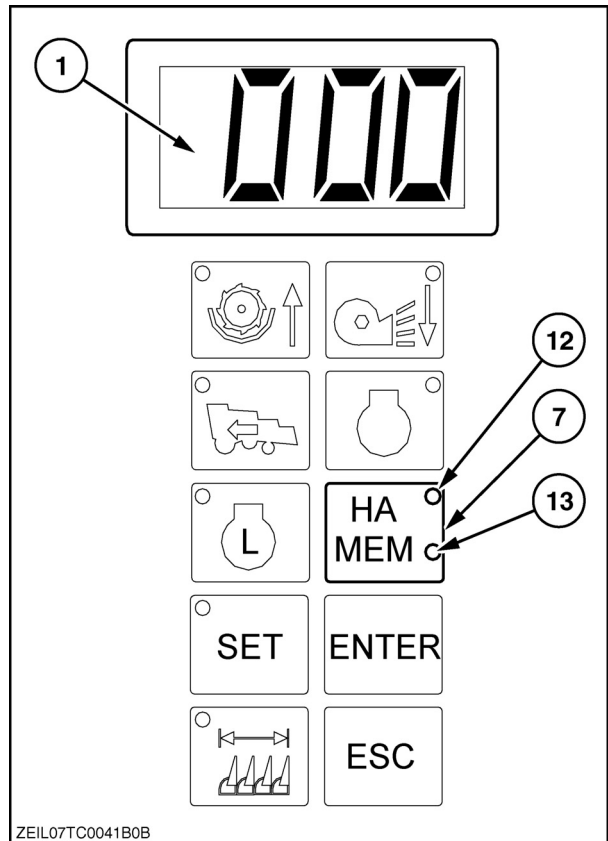

Storing partial area

The partial area can be stored into the memory (stored area) if the value is bigger than zero and the ground speed = 0.

To do this job, proceed as follows:

1. Put the ignition key on.
2. Set the partial area on the display (1) by pressing once on the button (7).
3. Press the “ENTER” button (9) until the beep is working.
4. The partial area is shifted into the memory and current partial area is reset to zero. (Previous stored area is lost and replaced by the new area). Both leds are flashing alternately.

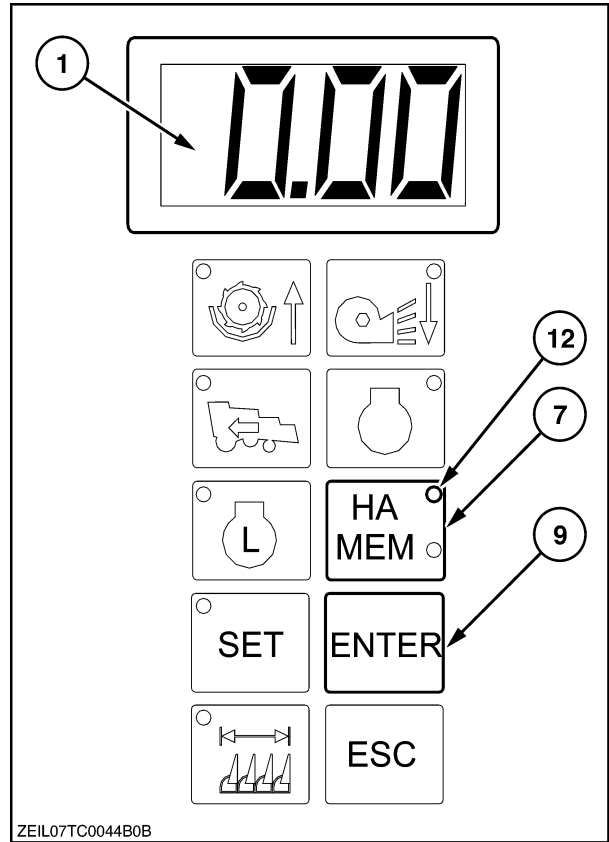

■ **Software version**

To view the **Control Module** software version on the display (1): Press simultaneously button (2) and (3).
(Drum speed and cleaning fan speed button)

To view the **monitor** software version on the display (1):
Press simultaneously button (9) and (11).
(Enter and escape button)

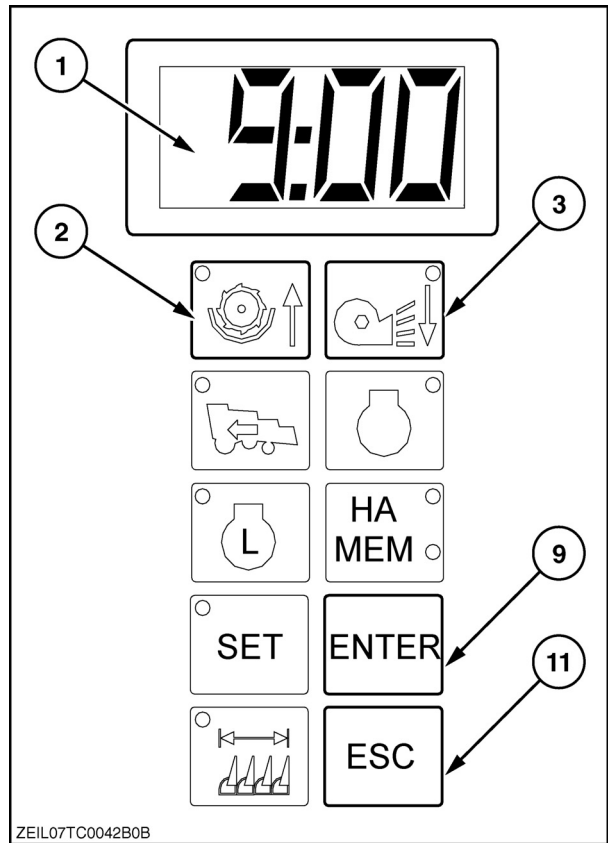

AUDIBLE ALARM

An audible signal (buzzer) is provided with a continuous **low** level and a intermittent **high** level noise, depending of the alarm conditions.

NOTE: When the alarm is functioning, try to locate the defect or contact your local dealer for assistance.

The noise level of the audible alarm can be adjusted.

To adjust, proceed as follows:

1. Press simultaneously the button (10) (Header width correction) and (11) (escape) to become a low level noise (L).
2. Use the button (2) (drum speed) or (3) (fan speed) to adjust the low noise level between 1 and 15 that can be viewed on the display (1) "L XX".
3. Press the "ENTER" button (9) for minimum two seconds to validate and the routine jumps to the high level noise (H) adjustment.
4. Use the button (2) (drum speed) or (3) (fan speed) to adjust the high noise level between 17 and 50 that can be viewed on the display (1) "H XX".
5. Press "ENTER" button (9) for minimum two seconds to validate.

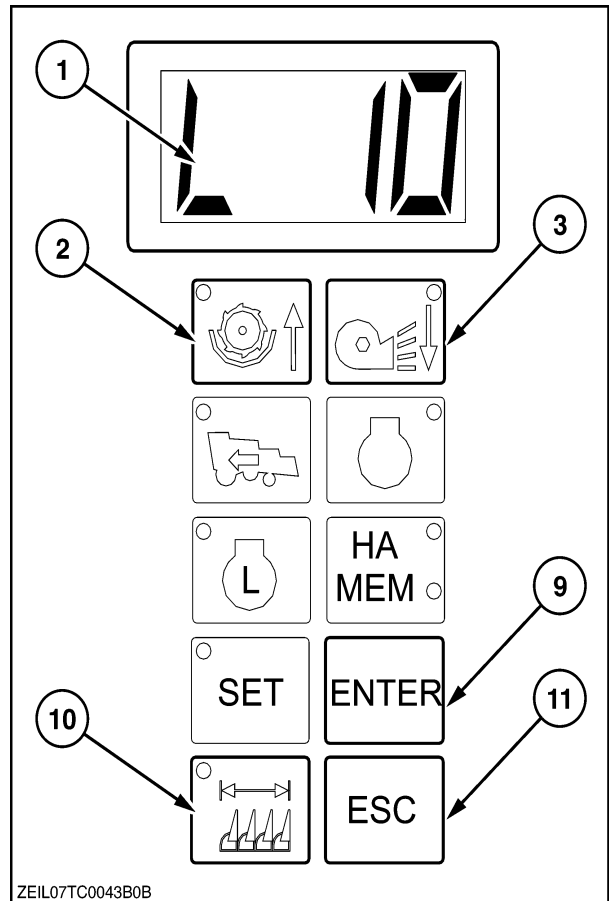

ZEIL07TC0043B0B

Machine error messages

When the ignition key is set in the contact position, possible error(s) will be indicated on the display (1).

The error will be displayed for 10 seconds every 60 seconds as long as the error condition is true. A short buzzer beep is generated every time the error message appears, this for maximum 5 times.

When pressing the “ESC” button (11), the error indicated on the display (1) will be deleted and a possible second error will be indicated on the display.

To delete all indicated errors from the display (1) at once, press on the “ESC” button (11) at least two seconds.

A list with the error messages can be found in SECTION 5 – FAULT FINDING; paragraph headed: “Machine error messages”.

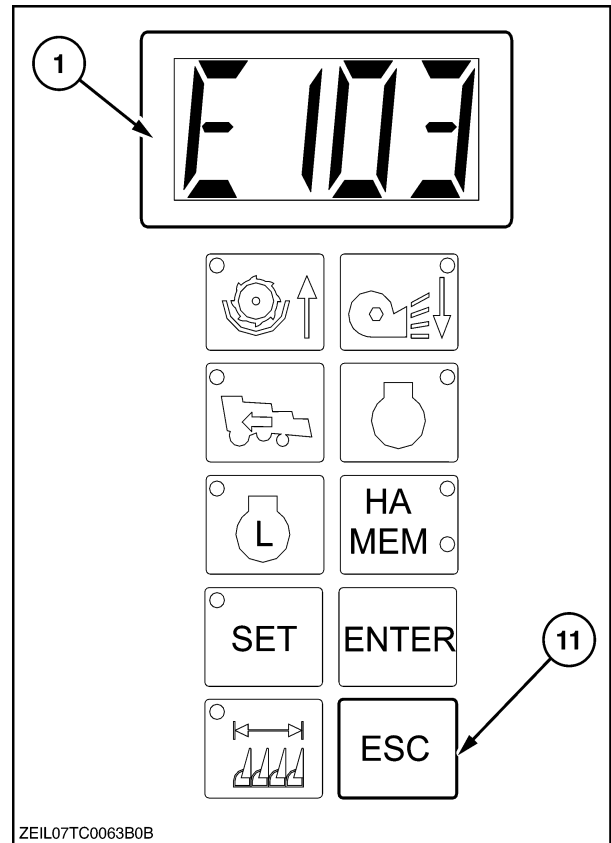

■ Engine error messages

The engine error codes are categorised as High or Low priority.

A Low priority code (L) will cause the error to be displayed for 10 seconds every 60 seconds for as long the error persists. A short beep should accompany each error display for maximum 5 times.

A High priority code (H) will cause the display (1) to flash “STOP” alternating with the error code “FXXX” or a specific message (HEAt, SHUn,...).

IMPORTANT: It is the operator's responsibility to stop the engine immediately when this message appear.

A list with the engine error messages can be found in SECTION 5 – FAULT FINDING; paragraph headed: “Engine error messages”.

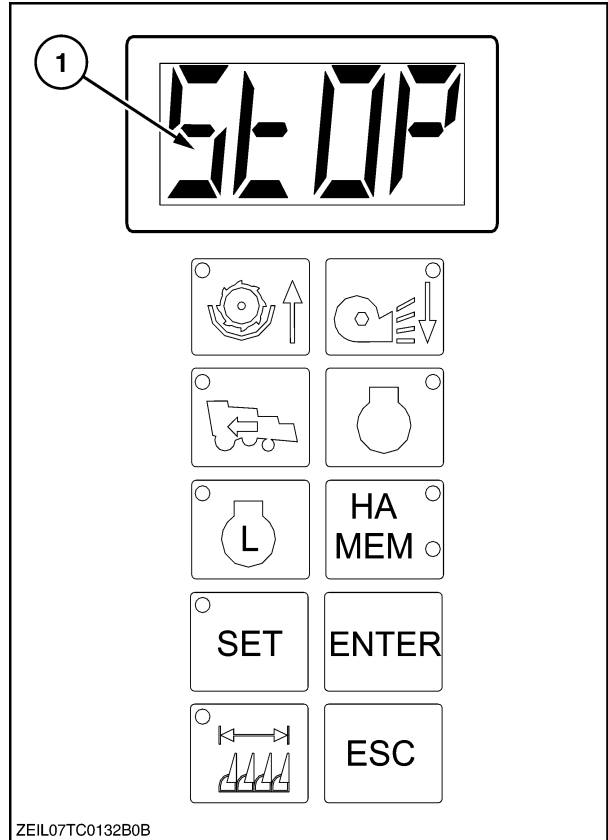

Shaft speed calibration

The determination of the maximum shaft speeds is based on a measuring period.

This period starts when:

- after ignition key, the engine runs for the first time at full throttle with the threshing mechanism engaged.

or

- each time the engine runs at full throttle with the threshing mechanism engaged and pressing the “ENTER” button for minimum one second on the monitor.

NOTE: *In case the operator increase the cleaning fan speed or the drum speed during harvesting, and a manual calibration is not done afterwards, then an automatic calibration will be start as soon the engine is at high idle.*

Shaft speed alarm indications

A first warning buzzer alarm of 3 seconds (low level) + solid alarm led will be generated when the speed drops under 85%.

A last warning buzzer alarm of 8 seconds (high level) + flashing alarm led will be generated when the speeds drops under 70%.

IMPORTANT: *If a warning light starts glowing during operation and the buzzer alarm is working, the rpm of the corresponding shaft is no longer correct (i.e. slow-down of speed due to belt slippage, broken belt, etc.) In this case stop the machine immediately and investigate the cause of the problem.*

Shaft speed sensor failure

If immediately after a shaft speed drop calibration one or more leds are glowing means no speed detection (sensor distance too big).

If there is a problem with a shaft speed sensor, an error will be viewed on the display. A list of errors with an explanation can be checked.

Refer to “SECTION 5 – FAULT FINDING”; paragraph headed: “ERROR MESSAGES”.

Automatic shut-off

- In case of mechanical control:
the engine will automatically shut-off when:

leaving the operator’s seat after first a warning via buzzer + led.

or

bringing the rear ladder down
- In case of remote control:
the header will be disengaged after 7 seconds when:

leaving the operator’s seat.

or

the threshing will be disengaged when:

bringing the rear ladder down

SECTION 3 – FIELD AND SITE OPERATION

BEFORE DRIVING THE COMBINE

1. Read this Operator's Manual carefully; especially the paragraphs headed "safety precautions" and "starting the engine".
2. Check all chain and belt tensions. Refer to "SECTION 4 – LUBRICATION AND MAINTENANCE".
3. Check all the pressures daily. Keep the tyres inflated to the pressures given in "SECTION 8 – SPECIFICATIONS".
4. Check the wheel nuts torque daily during the first week of operation and thereafter on a weekly basis.
5. Check the engine oil and coolant level (ensure the machine is standing on level ground). Refer to "SECTION 4 – LUBRICATION AND MAINTENANCE".
6. Check the hydraulic and hydrostatic oil [if applicable] reservoir level with all hydraulic cylinders retracted and the header lowered to the ground (machine standing on level ground). Add oil if necessary. Refer to "SECTION 4 – LUBRICATION AND MAINTENANCE".
7. Lubricate the combine completely as described in "SECTION 4 – LUBRICATION AND MAINTENANCE".
8. Sit down on the operator's seat and adjust it according to your weight and size.
9. Adjust the steering wheel to the desired position. Adjust the rear-view mirrors, if necessary.
10. Raise the ladder of the operator's platform when driving on public roads.
11. Raise the ladder of the engine compartment.
12. Ensure the unloading tube is in the closed position.
13. Start the engine. Refer to the next paragraph headed "Starting the engine".
14. Disengage the parking brake.
15. Move the engine throttle to maximum speed position.
16. Raise the straw elevator to its highest position.

IMPORTANT: To prevent the hydraulic oil from overheating, do not hold the header height control switch in the operating position longer than is necessary. The same applies to the hydraulic controls for the reel height, and the reel fore and after adjustment.

STARTING THE ENGINE

Ensure you are thoroughly familiar with the instruments and controls before starting the engine for the first time.

To start the engine safely, follow the points as outlined below.



CAUTION

Before starting the engine, ensure there is enough ventilation and everyone is standing clear of the combine.

Daily start-up procedure

Proceed as follows:

1. Carry out the routine engine service, i.e. check coolant, oil and fuel tank levels (refer to "SECTION 4 – LUBRICATION AND MAINTENANCE").
Ensure the battery key is in the "ON" position.
2. Ensure that the header, threshing and unloading mechanism are disengaged.
3. Ensure that the unloading tube swing tumbler switch is in neutral position.
4. Make sure the Multifunction handle is in neutral position.
5. On units with mechanical drive, depress the clutch pedal fully.
6. Check that both brake pedals are coupled together and that the parking brake is engaged.
7. Ensure that the gearshift control lever is in the neutral position.
8. Insert the ignition key into the ignition-and-stop switch and turn the ignition key in the "contact" position.

NOTE: The audible signal will sound (indicating parking brake engaged).

9. Before starting the engine, warn bystanders by sounding the horn several times.
10. Turn the ignition key clockwise to engage the starter motor (If the engine fails to start after 30 seconds, release the ignition key for about one minute before re-engaging the starter motor).
11. As soon as the engine starts, release the starter button.
12. Release the clutch pedal on mechanical drive units.

IMPORTANT: Allow the engine to run for minimum one minute at low idle before moving off, to ensure adequate lubrication of the turbocharger bearings and the hydrostatic pump. This is especially recommended in case of a cold start of the machine.

IMPORTANT: If the audible alarm does not cease functioning when the parking brake is disengaged, or if the warning lights for the engine oil pressure or hydrostatic charge pressure do not extinguish after the first few seconds of idling, stop the engine immediately and contact your dealer for assistance.

STOPPING THE ENGINE

Proceed as follows:

1. Move the engine throttle to its minimum position and let the engine run at idling speed for one minute.
2. Turn the ignition key counter-clockwise to stop the engine.

3. Remove the key from the ignition-and-stop switch.
4. Engage the parking brake.

DRIVING THE COMBINE

Familiarise yourself with the different steering and driving characteristics.



The combine rear end swings out when changing direction. Take care when taking turns.



To prevent runaway of the combine (i.e. when the ground speed increases during downhill driving and it is impossible to reduce the speed with the ground speed control lever), it is necessary to shift into a lower gear appropriate to the steepness of the hill.



Never drive on public roads with any of the mechanisms engaged.

Recommended gear use:

- For field operation, use first or second gear, depending upon the circumstances.
- For manoeuvring in confined spaces, use first gear.
- For road transport, use third or fourth gear.

NOTE: When reversing the combine, an audible alarm will automatically warn bystanders.

MECHANICAL DRIVE UNITS

Proceed as follows:

1. Fully depress the clutch pedal and move the gearshift lever into the desired gear.
2. Release the parking brake.
3. Release slowly the clutch pedal.
4. To increase speed, push the ground speed control lever forward.
To decrease speed, pull the ground speed control lever backwards.

NOTE: The action of depressing the clutch pedal automatically returns the ground speed variator to minimum.

5. Stop the machine completely before changing the gear.

HYDROSTATIC DRIVE UNITS

Proceed as follows:

1. Ensure that the ground speed control lever is in neutral position.
2. Move the gearshift lever into the desired gear.
3. Move the ground speed control lever forward from the neutral position to advance, or from the neutral position rearwards to reverse.

IMPORTANT: To prevent damage to the traction gearbox it is recommended to drive the combine slowly during the first minutes after a cold start of the machine.

COMBINE FUNCTIONS

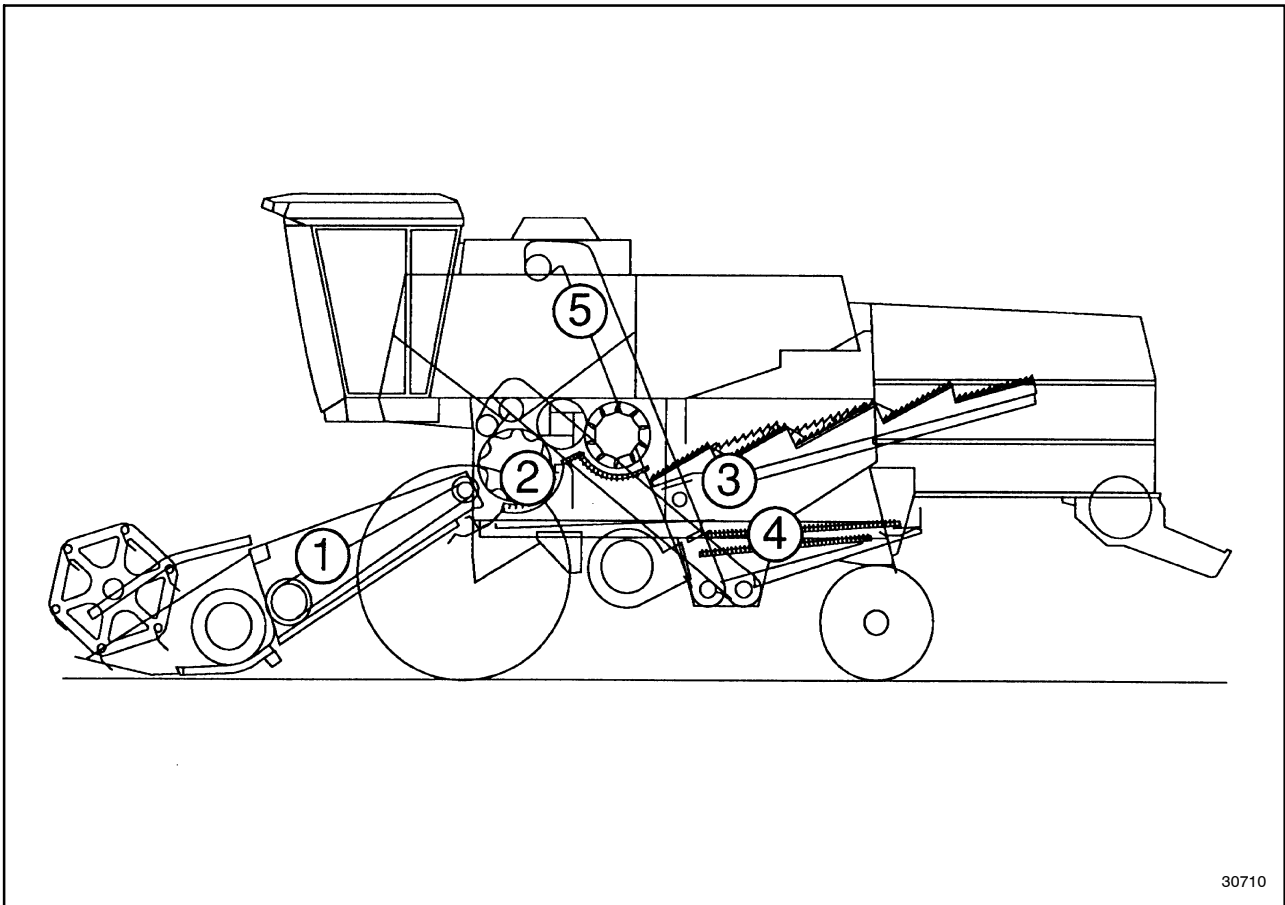

The combine operates according to five basic functions:

- | | |
|---------------|--------------------------------|
| 1. Feeding | 4. Cleaning |
| 2. Threshing | 5. Grain storage and unloading |
| 3. Separation | |

1. FEEDING

The reel 1 (on the grain header) or the gathering chains 1 (on the maize header) feeds the crop/cobs into the header 2 towards the auger 3. The auger 3 feeds the crop towards the middle of the header, where it is taken by the straw elevator 4. The crop is then carried up the straw elevator where it is fed over the stone trap 5 into the drum 6 and concave area 7. At this point the feeding is complete and the threshing starts.

The stone trap 5 is designed to trap stones and other foreign objects which may cause damage to internal parts of the combine.

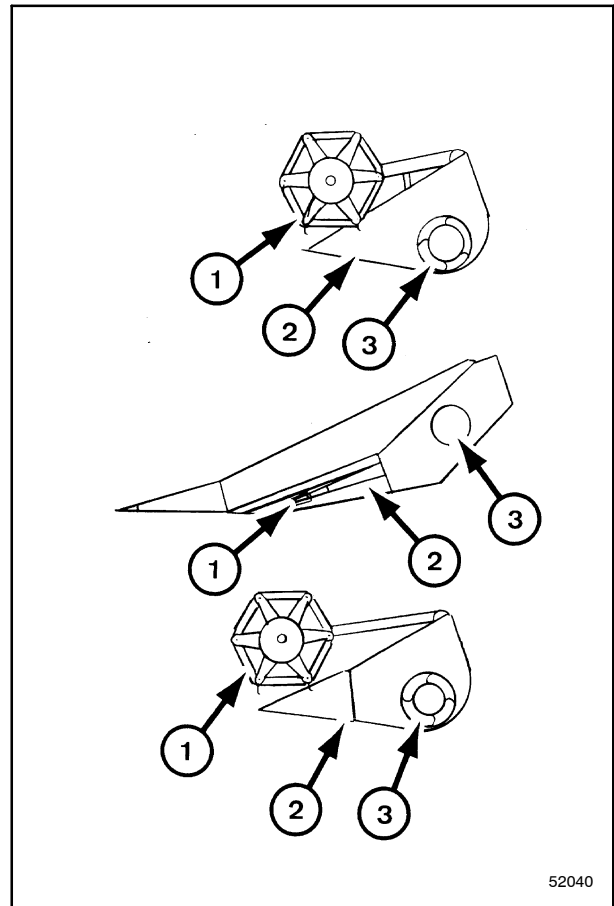

52040

2. THRESHING

As the drum 6 rotates, it rubs the crop against the concave bars 7. This rubbing action threshes the grain from the straw (approximately 90% of the grain).

- Clean grain falls onto the grain pan 8.
- Straw (and remaining grain) are guided to the beater 9.
- **De-awning slats** (accessory) can be installed on the front part of the concave to improve the threshing efficiency (especially important in wheat) and to avoid white caps.
- **De-awning plates** (two or four) can be installed underneath the concave to increase the rubbing action when threshing winter barley or difficult to thresh crops.

3. SEPARATION

If a rotary separator is installed:

The beater 9 strips the straw from the drum 6 and guides it into the rotary separator 10 and concave 11, which further separates the grain from the straw.

The straw retarding curtain 12 prevents the beater 9 or the rotary separator 10 from throwing the straw too far onto the straw walkers 13.

The straw walkers 13 oscillate, lift and tumble the straw, permitting the remaining grain to fall through the walkers and slide down the walkers return pans 14 onto the rear of the grain pan 8.

The straw is carried over the walkers and out of the back of the combine and is laid in a swath or chopped by the straw chopper 30 (if installed).

4. CLEANING

The grain and the chaff are moved to the front of the upper sieve 15 where a initial cleaning takes place.

The cleaning fan 16 blows the chaff over the upper sieve and extension 17 out of the machine, while the grain, unthreshed heads and small quantities of chaff fall onto the lower sieve 18.

The lower sieve 18 finally cleans the grain. Grain that passes through the lower sieve is carried over the grain plate 19 to the clean grain cross auger 20.

Unthreshed heads which do not fall through the lower sieve are transported by the returns cross auger 21 and returns elevator 22 to the drum for rethreshing.

SECTION 3 – FIELD AND SITE OPERATION

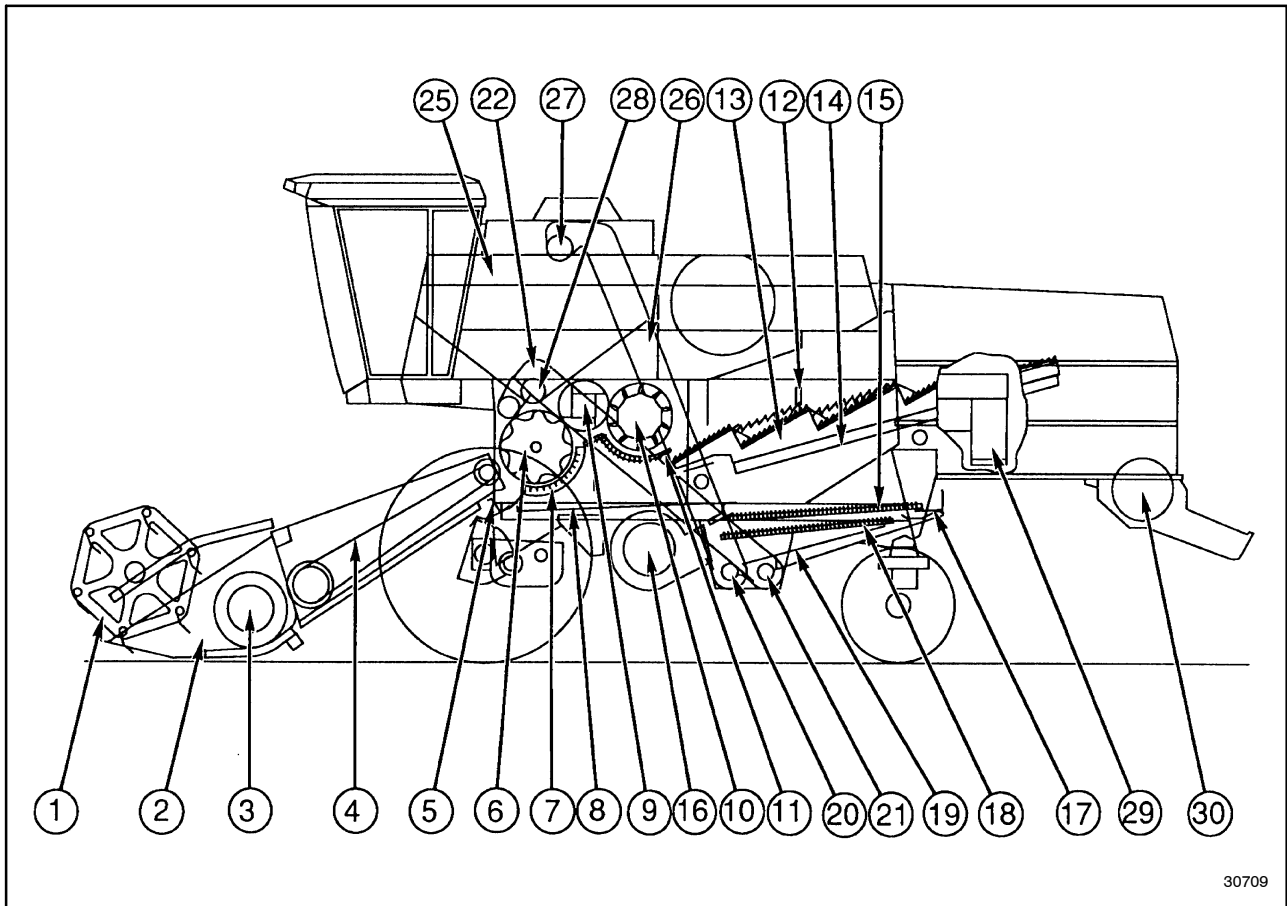

30709

3

- | | |
|---|--|
| 1. Reel | 17. Upper sieve extension |
| 2. Header | 18. Lower sieve |
| 3. Auger | 19. Grain plate |
| 4. Straw elevator | 20. Clean grain cross auger |
| 5. Stone trap | 21. Returns cross auger |
| 6. Drum | 22. Returns elevator |
| 7. Concave | 23. Grain pan divider (model with self-levelling cleaning system) see figure 6 |
| 8. Grain pan | 24. Sieve section (model with self-levelling cleaning system) see figure 6 |
| 9. Beater | 25. Grain tank |
| 10. Rotary separator (if installed) | 26. Grain elevator |
| 11. Rotary separator concave (if installed) | 27. Grain tank fill auger |
| 12. Retarding curtain | 28. Grain tank unloading auger |
| 13. Straw walkers | 29. Unloading tube auger |
| 14. Straw walker returns pan | 30. Straw chopper |
| 15. Upper sieve | |
| 16. Cleaning fan | |

SECTION 3 – FIELD AND SITE OPERATION

• With rotary separator

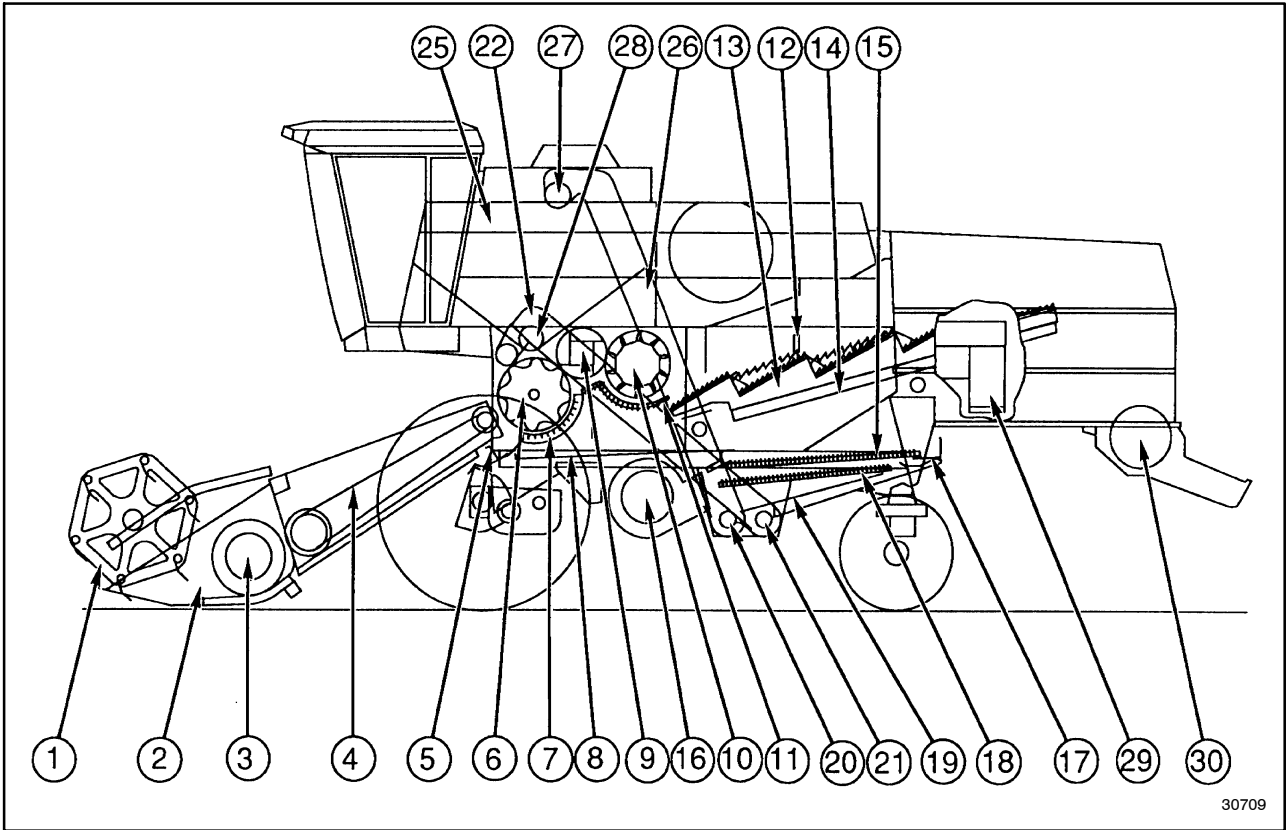

4

• Without rotary separator

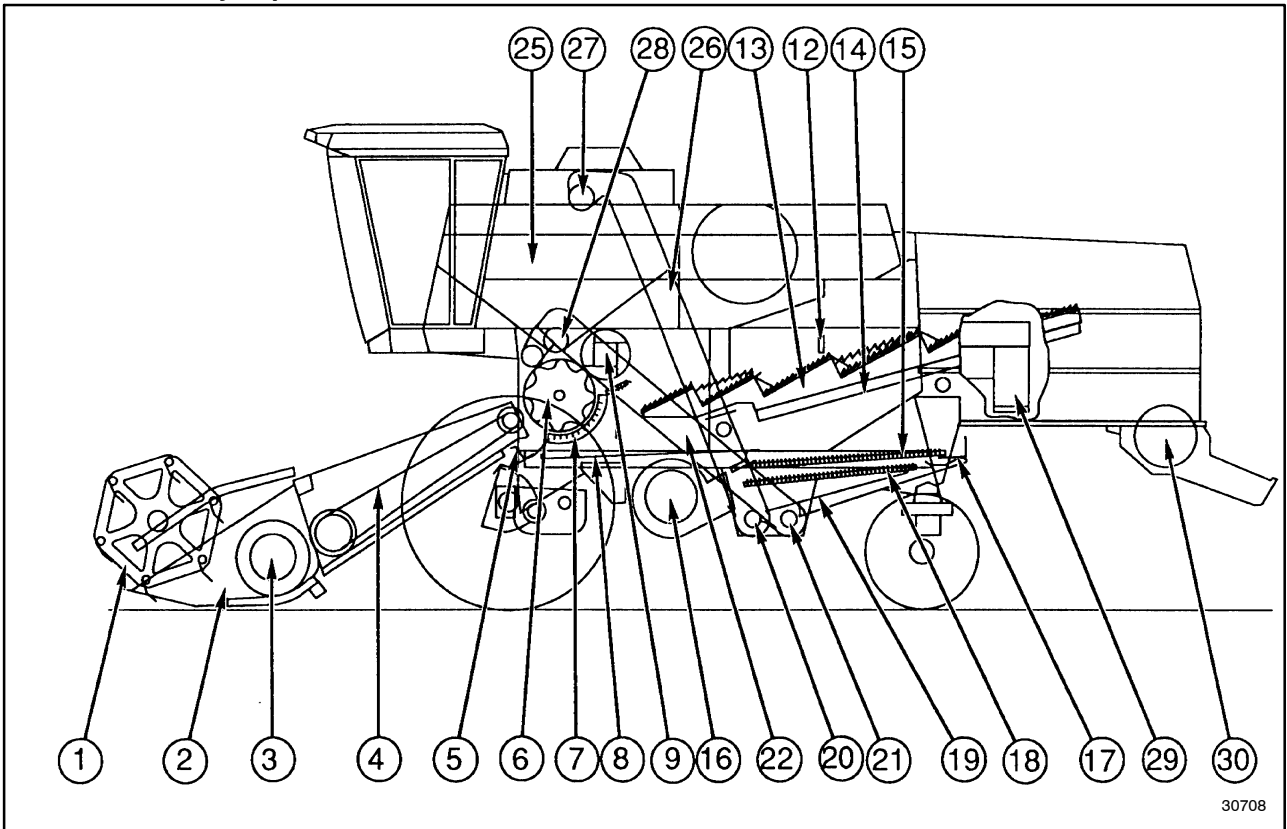

5

Self-levelling cleaning system (if installed)

The combine can be equipped with a self-levelling cleaning system [option] which increases the capacity of the cleaning shoe considerably when operating in hilly conditions.

The system functions as follows:

The grain pan dividers 23 pivot to direct the grain flow to the uphill side of the cleaning sieves, whereas the sieve section 24 stay horizontal position, to maintain full capacity on slopes up to 23%.

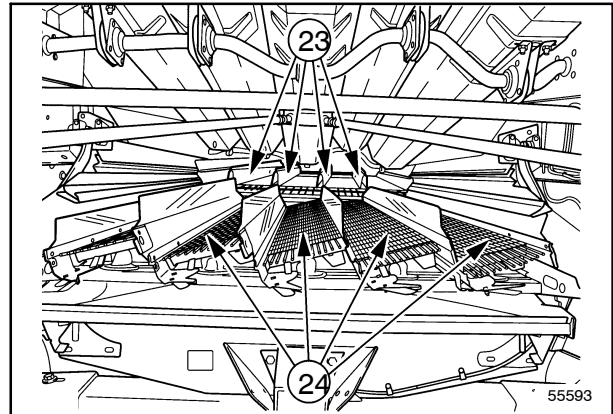

6

5. GRAIN STORAGE AND UNLOADING

The clean grain is channelled into the grain tank 25 by the clean grain cross auger 20, the grain elevator 26 and by the grain tank fill auger 27.

The grain tank is emptied by the grain tank unloading auger 28 and the unloading tube auger 29.

SUMMARY OF THE MACHINE SETTINGS FOR DIFFERENT CROPS

CROP TYPE	OPTIONAL EQUIPMENT	CONCAVE RPM	CONCAVE POSITION
WHEAT	–	700 – 1000 rpm	Position 2 10 x 10 mm
SUMMER BARLEY	–	800 – 1000 rpm	Position 1 or 2 10 x 10 mm
WINTER BARLEY	De-awning plates	800 – 1000 rpm	Position 1 or 2 10 x 10 mm
RYE	–	1000 rpm	Position 2 or 3 10 x 10 mm
TRITICALE	–	700 – 1000 rpm	Position 2 or 3 10 x 10 mm
OATS	–	800 rpm	Position 2 10 x 10 mm
RICE	<ul style="list-style-type: none"> • Peg tooth drum and concave • Tracks 	650 – 700 rpm	Position 4 20 x 25 mm
MAIZE	Maize concave	400 – 500 rpm	Position 7 25 x 30 mm
FLAX	–	800 – 1000 rpm	Position 1 or 2

SECTION 3 – FIELD AND SITE OPERATION

STRAW-RETAINING CURTAIN (if no rotary separator)	STRAW WALKER	FAN SPEED	SIEVE OPENINGS		STRAW CHOPPER (if installed)	
			Upper	Lower	Speed	Counter-knives (position)
Rear (front position in light straw crops)	When extremely dry, install vertical cover plates	700 – 800 rpm (lever position: 9.5 – 12)	8 – 12 mm	4 – 6 mm	high	inside
Rear	When extremely dry, install vertical cover plates	700 – 800 rpm (lever position: 9.5 – 12)	8 – 12 mm	4 – 6 mm	high	inside
Rear (front position in light straw crops)	When extremely dry, install vertical cover plates	700 – 800 rpm (lever position: 9.5 – 12)	8 – 12 mm	4 – 6 mm	high	inside
Rear	When extremely dry, install vertical cover plates	700 – 800 rpm (lever position: 9.5 – 12)	8 – 12 mm	4 – 6 mm	high	inside
Rear	When extremely dry, install vertical cover plates	700 – 800 rpm (lever position: 9.5 – 12)	8 – 12 mm	4 – 6 mm	high	inside
Rear	When extremely dry, install vertical cover plates	550 – 700 rpm (lever position: 7 – 9.5)	8 – 10 mm	4 – 5 mm	high	inside
Rear	-	650 – 800 rpm (lever position: 9 – 12)	8 – 12 mm	4 – 6 mm	high	inside
Front or rear	-	800 rpm max. (lever position: 9.5 – 15)	HC 1-5/8" 12 – 15 mm	Round-hole sieve 10 or 16 and/or 18 mm	low	outside
Rear	-	500 – 550 rpm (lever position: 6 – 7)	4 – 5 mm	2 – 3 mm	high	inside

SECTION 3 – FIELD AND SITE OPERATION

CROP TYPE	OPTIONAL EQUIPMENT	DRUM RPM	CONCAVE POSITION
RAPE SEED	–	600 – 650 rpm	Position from 3 to 5
GRASS SEED	Grass seed equipment Cover fan entrance	700 – 900 rpm	Position 1
BEANS/PEAS	Perforated auger and elevator covers	450 – 500 rpm	Between position 4 and 6
SOYA BEANS	– Maize concave – Perforated auger and elevator covers	450 – 500 rpm	Position from 4 to 5
SUNFLOWER	–	450 – 550 rpm	Position from 4 to 6
SORGHUM	–	450 – 600 rpm	Position 2 10 x 10 mm
SAFFLOWER	–	450 – 600 rpm	Position from 4 to 6
MUSTARD	–	500 – 600 rpm	Position from 3 to 5
BUCKWHEAT	–	500 – 600 rpm	Position 2 10 x 10 mm

SECTION 3 – FIELD AND SITE OPERATION

STRAW-RETAINING CURTAIN (if no rotary separator)	STRAW WALKER	FAN RPM	SIEVE OPENINGS		STRAW CHOPPER (if installed)	
			Upper	Lower	Speed	Counter knives (position)
Rear	-	450–500 rpm (lever position: 5 – 6)	8 – 10 mm	Round-hole sieves 2, 3 mm or 3.5 mm	high	outside
Rear	-	Minimum	10 – 12 mm 3/8" – 1/2"	6 mm (1/4.)	high	inside
Rear	-	750 – 900 rpm (lever position: 10.5 – 14)	10 – 15 mm with extension	Round-hole sieves 6, 8 mm or 16 and/or 18 mm	high	outside
Rear	-	700 – 900 rpm (lever position: 9.5 – 10.5)	10 – 15 mm with extension	Round-hole sieves 6 – 8 mm or 16 and/or 18 mm	high	inside
Rear	-	600 – 650 rpm (lever position: 8 – 9)	10 – 12 mm	6 – 8 mm	low	outside
Rear	-	700 – 850 rpm (lever position: 9.5 – 13)	8 – 12 mm	5 – 6 mm	high	inside
Rear	Install the vertical cover plates	650 – 800 rpm (lever position: 9 – 12)	10 – 12 mm	5 – 6 mm	high	inside
Rear	-	500 – 600 rpm (lever position: 6 – 8)	8 mm	5 mm	high	inside
Rear	-	500 – 600 rpm (lever position: 6 – 8)	8 – 12 mm	8 mm	high	inside

SECTION 3 – FIELD AND SITE OPERATION

TO CHANGE FROM GRAIN TO MAIZE, THE FOLLOWING MODIFICATIONS NEED TO BE DONE.

ACTION	SECTION	PAGE
1. Adjust the straw elevator bottom shaft.	<i>FIELD AND SITE OPERATION</i>	3-36
2. Install third straw elevator lift cylinder.	<i>ACCESSORIES</i>	7-2
3. Change grain concave to maize concave.	<i>FIELD AND SITE OPERATION</i>	3-43
4. Block the drum concave.	<i>FIELD AND SITE OPERATION</i>	3-55
5. Install the grain elevator high speed kit.	<i>FIELD AND SITE OPERATION</i>	7-8
6. Remove the anti-dust plate and the anti-wrap shields.	<i>FIELD AND SITE OPERATION</i>	3-50
7. Install drum cover plates to reduce grain crackage.	<i>ACCESSORIES</i>	7-5
8. Low speed of the rotary separator (if installed).	<i>FIELD AND SITE OPERATION</i>	3-59
9. Adjust the straw retarding curtain in the front position.	<i>FIELD AND SITE OPERATION</i>	3-60
10. Remove the chaff spreader completely (if installed).	<i>FIELD AND SITE OPERATION</i>	3-87
11. Install lower round hole sieve 16 or 18 mm.	<i>FIELD AND SITE OPERATION</i>	3-62
12. Install upper sieve for maize (HC 1-5/8").	<i>FIELD AND SITE OPERATION</i>	3-65
13. Install fan bottom shield.	<i>ACCESSORIES</i>	7-7
14. Install wear plates on the rotary separator. (if installed)	<i>FIELD AND SITE OPERATION</i>	3-59
15. Install the rotary dust screen brush (wet conditions).	<i>ACCESSORIES</i>	7-14
16. Install counterweights as required.	<i>SPECIFICATIONS</i>	7-18
17. If a chopper is installed, modificate the chopper to maize configuration.	<i>FIELD AND SITE OPERATION</i>	3-82
18. Install additional light kit if required (flip-up headers).	<i>ACCESSORIES</i>	-
19. Change the setting of the combine performance monitor (sieves and straw walkers) (if installed).	<i>CONTROLS, INSTRUMENTS AND OPERATION</i>	2-26
20. Change hectare counter settings.	<i>CONTROLS, INSTRUMENTS AND OPERATION</i>	2-35

COMBINE PERFORMANCE CHECK

Kill stall

The only way to accurately check the performance of the combine is to complete a "kill-stall".

1. Operate the combine in a section of the field that best represents the overall crop. Be sure the combine is at least 100 m (328 ft) into the crop and travelling at the normal operating ground speed.
2. Press on the "ESC" button for minimum four seconds to get an engine quick "kill-stall". Apply the brakes gently and allow the combine to stop. This will leave crop material as it was during actual harvesting.
3. Disengage the threshing and header engagement system.
 - If hydrostatic drive: Move the multi function handle to neutral.
 - If mechanical drive: Press down on the clutch pedal and move the gearshift lever into neutral.
4. Move the throttle control to the lowest position and restart the engine immediately. This prevents the engine from overheating and from being damaged. Run the engine on low idle for five minutes before stopping the engine.
5. Check the grain tank sample for complete threshing, cleanliness and damage.
6. Walk out in the front of the header and check the crop loss before the header has contacted the crop (preharvest loss).
7. Check the crop loss in an area where only the header has travelled (header loss).
8. Check the distribution of material on the grain pan.
9. Check the type, amount and distribution of material on the sieves.
10. Check the type and amount of returns.
11. Check the total loss in a 60 cm (23-5/8") wide area across the width of the straw walkers. Subtract preharvest and header losses to determine the machine loss. Use a drop screen to check the machine loss directly.

12. With all previous factors considered, readjust the combine.

NOTE: Make only one adjustment at a time so that any change in combine performance can be attributed to that particular adjustment.

Performance indicators

There are four indicators, which will tell you how well the combine is performing. These four indicators are:

- Grain tank sample
- Distribution of material on the grain pan and upper sieve
- Type and amount of returns
- Losses

By correctly reading these indicators and being familiar with the combine, you can make the necessary adjustments to correct any problem and improve the overall combine performance.

Grain tank sample

A large amount of trash in the grain tank indicates the crop is being overthreshed and/or the cleaning fan speed is too slow. The first step to correct this problem is to increase the concave clearance and/or reduce the drum speed. This reduces or eliminates the material break-up caused by overthreshing. Then increase the cleaning fan speed if the trash is heavier than the grain or close the upper sieve if the trash is larger than the grain.

Cracked or damaged grain is mainly caused by too high drum speed. Increase the concave clearance and then reduce the drum speed to correct the problem.

Bunch feeding can cause grain damage in the straw elevator. An incorrect straw elevator chain tension can also cause grain damage.

Excessive returns will contribute to grain damage due the additional pass(es) the grain must take through the drum/concave area. Plugged concave can cause grain damage because the free grain cannot get out of the concave area.

Loose elevator chains can also cause grain damage. It is important to maintain the proper tension on these chains.

Unthreshed material in the grain tank can be caused by underthreshing or the lower sieve that is opened too wide. Increase the drum speed and reduce the concave clearance as needed to correct the problem. Reduce also the lower sieve opening slightly to obtain a cleaner grain tank sample.

■ Grain pan/upper sieve distribution

The distribution of material on the grain pan affects the distribution of material on the sieve. The distribution on the grain pan should be level.

The front third of the upper sieve should be completely clean. The middle third should have some grain but mostly residue. The rear third of the upper sieve should have only residue.

If there is some grain on the rear third of the upper sieve, returns will be increased and there is a possibility that grain will ride out the back of the combine. Open the upper sieve to allow more of the grain to fall onto the lower sieve.

If the material on the upper sieve is broken into small pieces, the crop is being overthreshed. This can plug the upper sieve and cause high losses. Increase the concave clearance and/ or reduce drum speed to decrease the threshing action.

Unthreshed heads indicate the drum speed should be increased and/ or the concave clearance should be reduced. Unthreshed heads can also be caused by worn rasp bars and worn concaves.

Return sample

It is normal for the return sample to contain a few unthreshed heads. The purpose of the returns system is to return unthreshed heads to the threshing area for another pass. However, a large quantity of unthreshed heads indicates the concave clearance is too wide.

If the return sample contains a large quantity of clean grain, the cleaning fan speed should be reduced and/ or the lower sieve should be opened more.

Losses

Losses may occur at different stages: (see fig. 7)

1. **Pre-combining losses:** (i.e. losses found in front of the combine) are usually caused by adverse weather conditions, poor crop conditions and crop maturity.
2. **Header losses:** (i.e. losses found behind the header and outside of the tyres) may be caused by improper header adjustments.
3. **Leakage losses:** may be caused by damaged seals or holes in bottom auger covers.
4. **Cleaning shoe losses:** may be caused by a poor sieve adjustment, a low or too high cleaning fan speed, or when working on slopes (exceeding the capacity of the self levelling system (if fitted)).
5. **Straw walker losses:** These can be unthreshed ears (underthreshing) or grains, due to poor adjustment of drum and concave or excessive ground speed.

Total losses (Lt) caused by the machine:

$$L_t = (2 + 3) + (4 + 5) - 1$$

Functional losses (Lf)

$$L_f = 4 + 5$$

SECTION 3 – FIELD AND SITE OPERATION

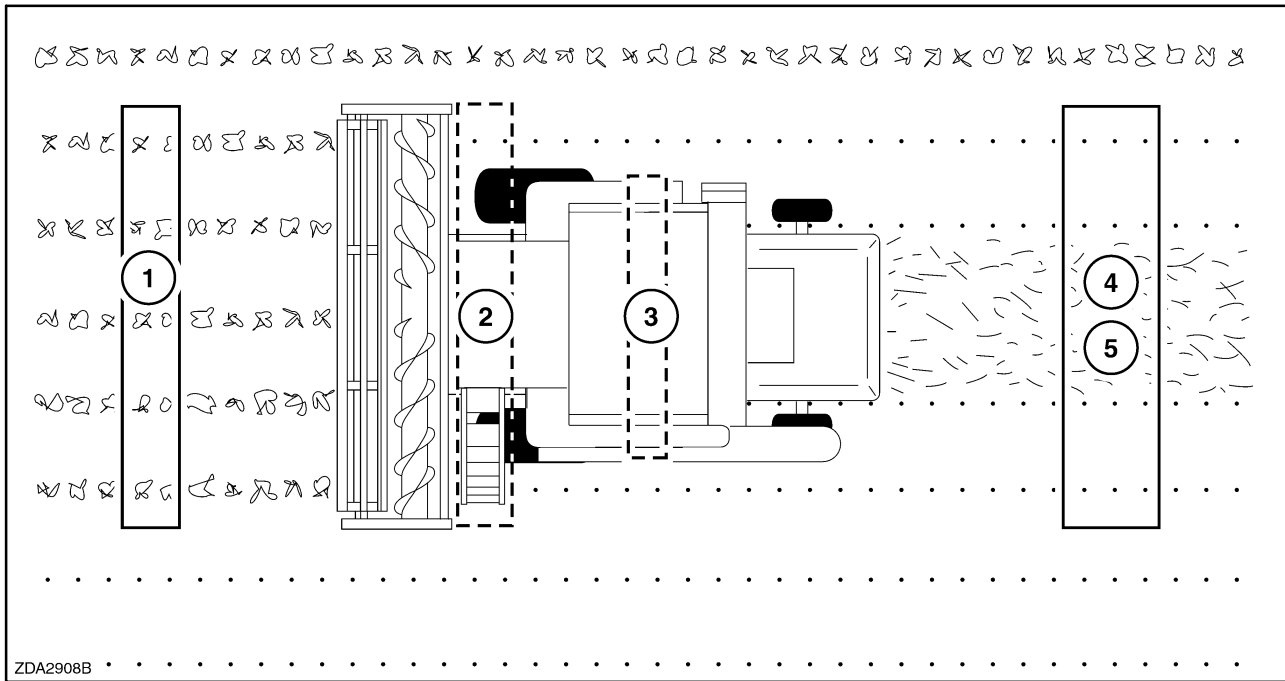

ZDA2908B

7

The area of loss is determined by the location of the grain in relation to the combine. Each of these areas must be checked to accurately determine which combine adjustments (if any) can be made to reduce the loss.

Grain on the ground in front of the combine head is defined as preharvest loss and is usually caused by the weather. Determine the amount of this loss before taking the combine into the field.

Grain found behind the head, but to the outside of the drive tyres, is considered loss from the head. These losses can be caused by improper head adjustments or improper combine ground speed.

Grain on the ground directly behind the combine and the width of the shoe is caused by incorrect combine adjustment(s), too high a ground speed, or leakage. Holes in the auger bottoms and damaged seals can result in large losses which are often mistaken for shoe and straw walker losses.

Shoe losses can be caused by a build-up of material on the top sieve which allows the grain to ride out the back of the combine. This can be due to the sieve opening being closed or opened too much, the rear of the sieve raised too high (sieve angle too extreme), by a too low cleaning fan speed or a sieve overload by too aggressive threshing in brittle crops.

Losses can also be caused by a cleaning fan speed that is too high. The grain is then blown out of the back of the combine.

An uneven loading of material on the top sieve can also cause losses.

How to obtain an idea on loss level

Example:

A 6-straw walker combine with a 17 ft (5.10 m) grain header operating in wheat.

Average yield: 5000 kg/ha.

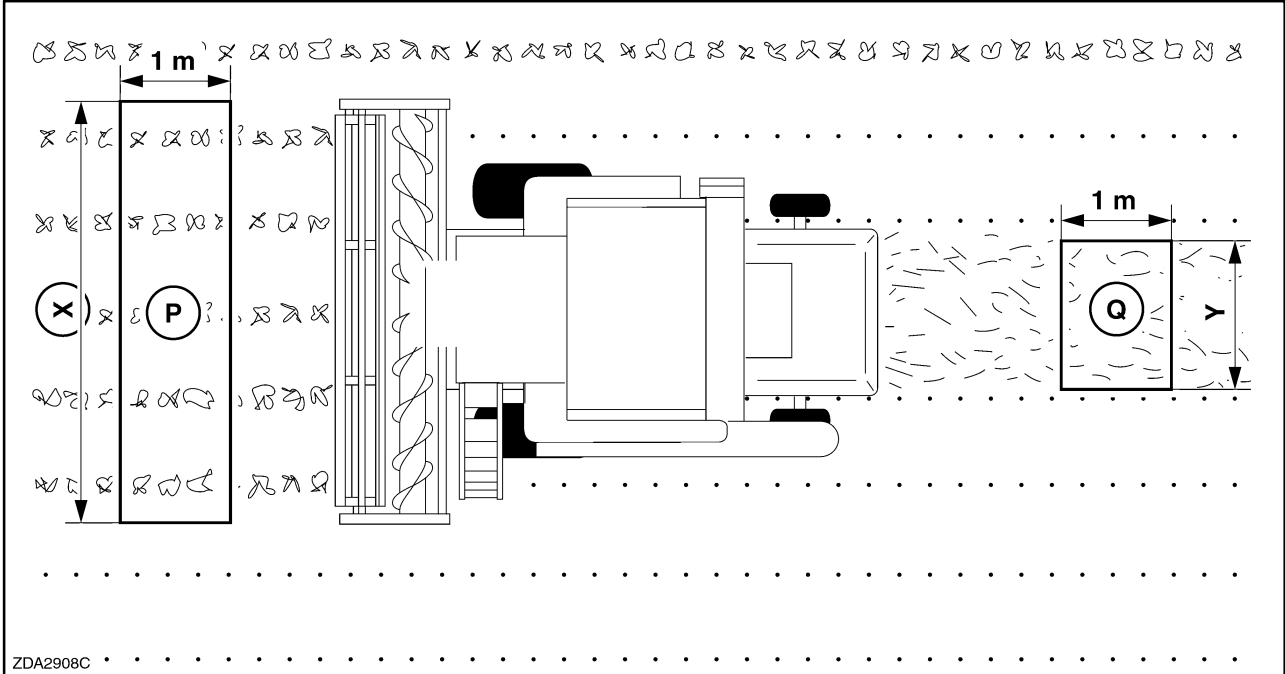

ZDA2908C

- Surface P= surface being harvested:
1 meter multiplied by X (header width) = 5.10 m².
- Surface Q = surface of the material being cut in surface P, behind the machine (i.e. swath):
1 meter multiplied by Y.
(drum width, i.e. 1.5 meter) = 1.5 m².
- Consider a **loss level of 1%** = 50 kg/ha or 5 grams/m² crop.
Surface Q will then contain the functional losses (i.e. cleaning shoe, straw walker, fan) of surface P (5.1 m²), being 5x 5.1 = 25.5 grams.
- Considering the average weight of wheat being 23000 grains/kg, this means: 586 grains in surface Q. (1% loss level!)
- An average human hand with spread fingers covers a surface of approximately 0.03 m². This means that, if the grain loss is evenly spread, 18 grains can be found underneath the hand, representing 1% grain loss for a 5000 kg/ha yield.

HEADER

Attaching the header to the combine

Proceed as follows:

1. Make sure that the top of the straw elevator where the header is attached is clean.
2. Position the combine to align the straw elevator with the header aperture.
3. Lower the straw elevator until the hooks 1 just clear the upper side of the header opening.
4. Drive the combine until the straw elevator rests on the header. Then, lift the straw elevator together with the header.
5. Attach the quick-attach lever 2 so that the hooks are in full contact with the pins 3. If not, pins 3 must be adjusted in the slot.
6. Adjust the lever 2 with the bolts 4 so that a certain resistance is felt when engaging the latch 5 over the lever 2.
7. Connect the header drive coupling 6. Use the special tool 10, fitted to the left-hand side of the straw elevator to bring the splines of the straw elevator drive shaft in line with the splines of the header p.t.o. shaft.
8. Close the cover to protect the header drive coupling.

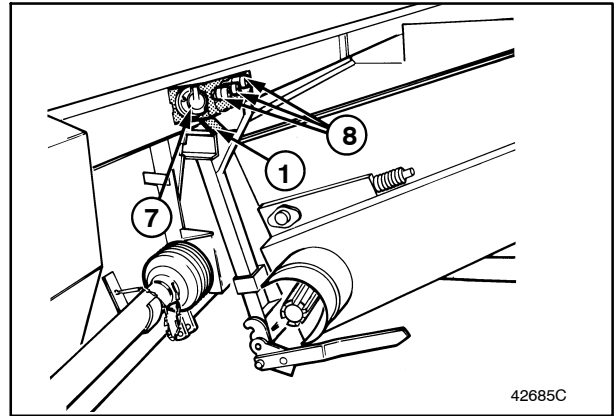

9

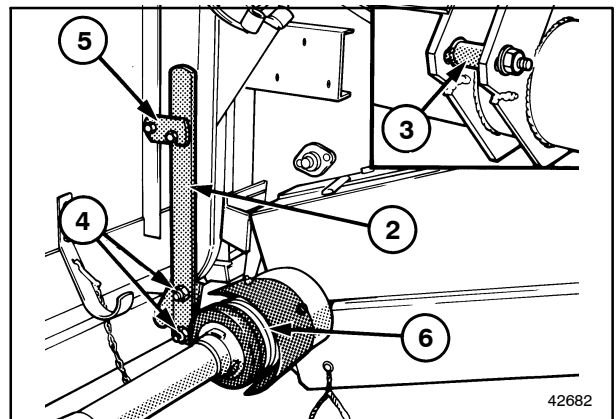

10

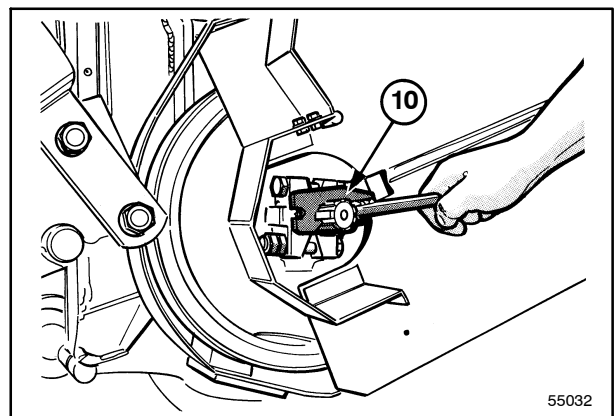

11

SECTION 3 – FIELD AND SITE OPERATION

9. Connect the electrical plug to socket 7.

10. Only for grain headers:

Connect the hydraulic hoses to the relevant hydraulic connections 8 of the header.

- Reel height adjustment: central coupling.
- Reel forward and after adjustment: coupling marked with black and white rings.

Fit the blanking plugs into each other.

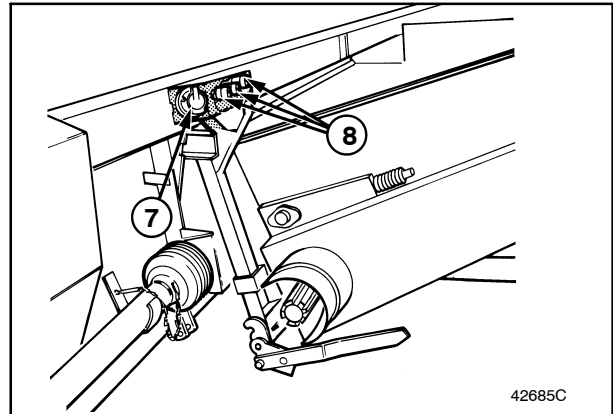

12

IMPORTANT: Avoid possible oil contamination by properly fitting the blanking plugs into the hydraulic couplers or into each other during operation.

In case of quick-coupling:

1. Connect the electrical plug 1 to the socket.

2. Open the cover 2.

3. Bring the hydraulic block to (4) and turn down the handle 5 until the lock 6 jumps into its security groove.

4. Connect the drive shaft 8 in position and check that the safety chain is connected.

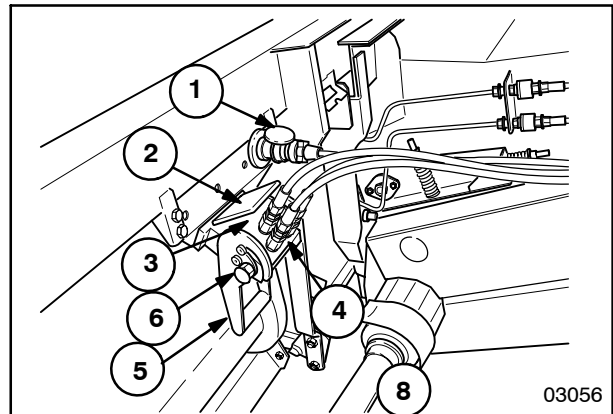

13

Detaching the header from the combine

To detach the grain header, proceed as follows:

1. Set the reel in its lowest and rearmost position.
2. Disconnect the following parts:
 - Header drive shaft (1)
 - Electrical connector (6)

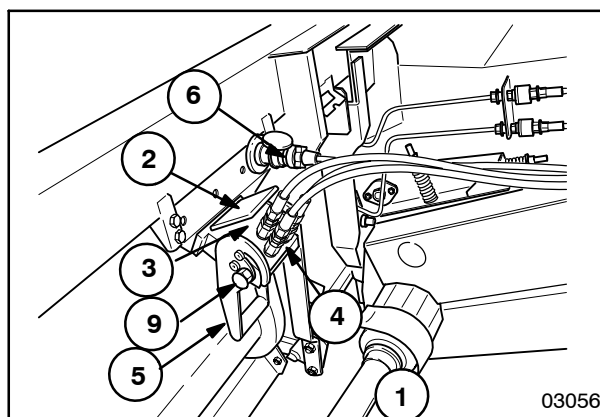

14

- In case of screw couplers:
Disconnect the hydraulic hoses from the header. Fit the blanking plugs in the header hydraulic connections and in the hoses. Attach the hydraulic hoses onto the support plate (12).

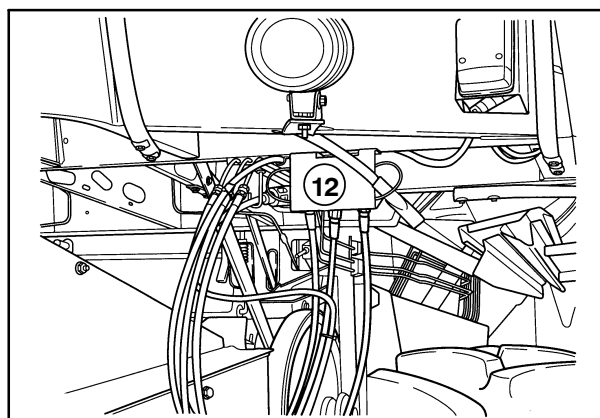

15

IMPORTANT: Avoid possible oil contamination by properly fitting the blanking plugs into the hydraulic couplers or into each other during operation.

- In case of quick-coupling: press on the latch (9) and turning over the handle (5). (fig. 14)
Remove the quick-coupling (3) and close the cover (2). (fig. 14)

3. Hook the electrical connector (6) and the quick-release coupler (7) onto support plate (8).

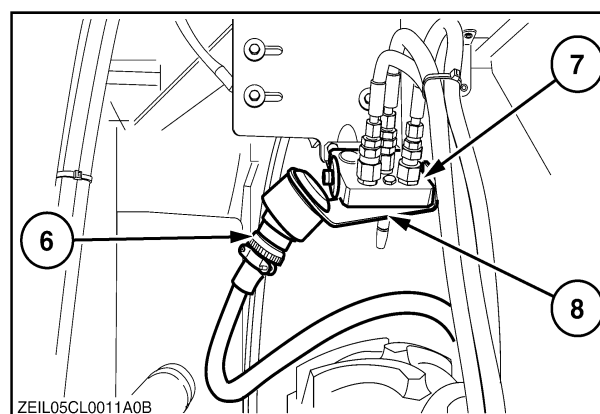

16

4. Open the latch 5 to release the lever 1.
5. Position the header on level ground or on the trailer.
6. At low engine rpm, lower the straw elevator to release it from the header.
Then, move the combine slowly rearwards.

Refer to the Operator's Manual of the header attached to your combine.

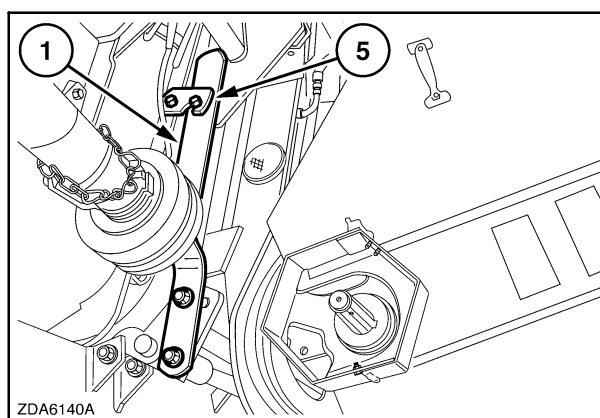

17

Header levelling

The header can be adjusted to ensure that it is parallel with the front axle by raising or lowering the right suspension 13.

Before adjustment operations, the following points must be checked:

- The combine must be on a level surface.
- Both drive wheels must be inflated at the same pressure.
- The header must be properly connected to the straw elevator.
- The header finger hoods must be mutually aligned.

Measure the distance between the finger guard tips and the ground at either end of the cutterbar. If there is a variation, adjust the distance by loosening the bolts 14 and adjust with the bolt 16.

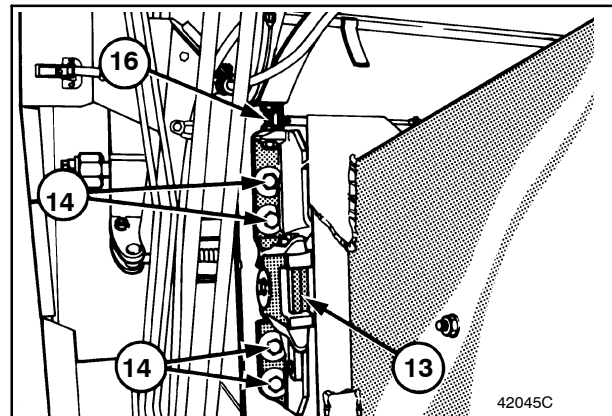

Header and straw elevator reversing system

The combine is equipped with a system to reverse the header auger (or the gathering chains, in case of a maize header), the auger and the straw elevator should a blockage occur.

If, during operation, a feed auger and/or a straw elevator blockage occurs which makes the slip clutch(es) slip, proceed as follows:

1. Stop the forward travel of the combine immediately and disengage the header drive by pressing on the top of the orange cap (3) or by using the header engaging lever (6).
2. Reverse the combine a few metres.
3. Let the engine run at **maximum** speed.
4. Press on the header and straw elevator reverser button (8) to reverse the rotation of the header and straw elevator.
5. When the blockage has been expelled, engage the header with the header engagement switch (3) or by using the header engaging lever (6).

IMPORTANT: It is not possible to remove all blockages using the reversing system. If necessary, remove the blockage manually. Refer to the next paragraph "header and/or straw elevator blockage-manual clearing".

NOTE: If the blockage can not be removed by the reversing system, stop the engine before attempting to unplug manually.

6. Continue operation.

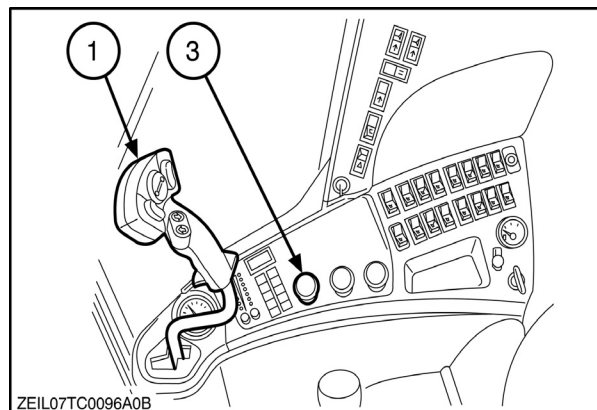

19

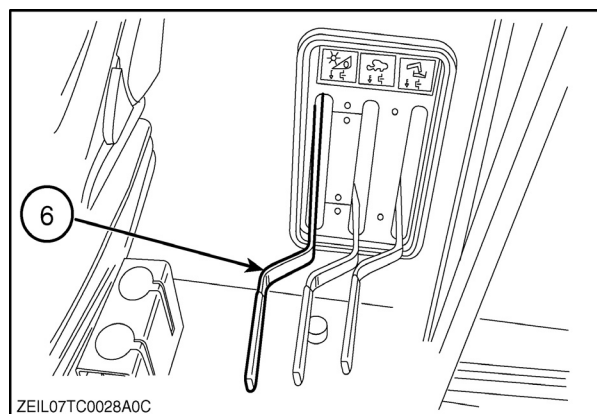

20

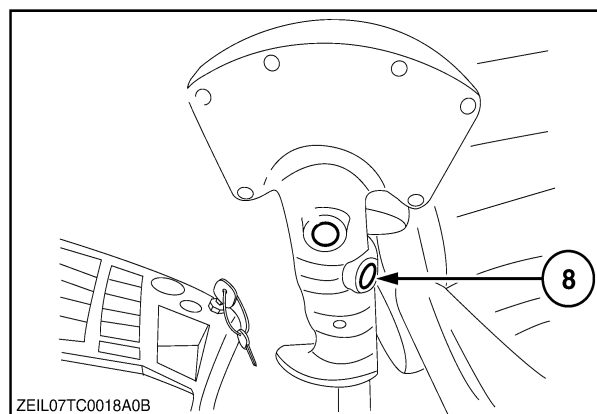

21

Manual clearing of the header and straw elevator blockage



If the blockage cannot be removed by means of the reversing system, disengage all engagement systems, stop the engine, remove the ignition key and wait until all moving parts have completely stopped.

If the blockage is situated at the upper shaft of the straw elevator, gain access through the cover on the top side of the straw elevator or detach the header with the straw elevator from the combine (refer to the paragraph headed "Straw elevator removal", further in this section).

If the blockage is situated at the straw elevator lower shaft, it will be necessary to detach the header. Refer to "SECTION 3 – FIELD AND SITE OPERATION", paragraph headed "Detaching the header from the combine".

Stubble height indicator (if applicable)

The crop cutting height can be read out on the stubble height indicator 6 which is located on the operator's platform.

If adjustment is necessary, proceed as follows:

1. Park the combine on a level ground.
2. Lower the header onto the ground.
3. Adjust the straw elevator cable so that the indicator pointer 7 indicates the mark 6.

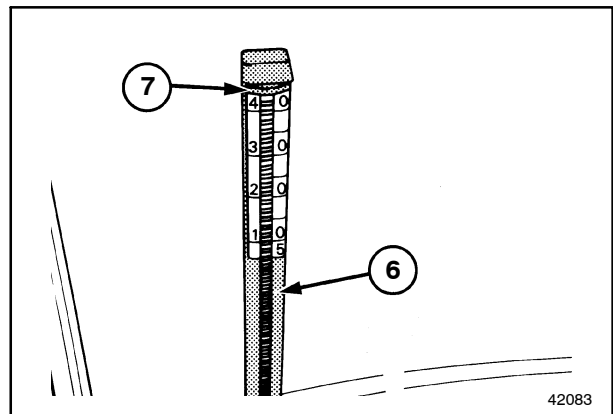

22

Header compensation gauge

A gauge (8) is incorporated in the hydraulic header lift system. When set correctly, the gauge informs the operator whether the combine is being operated with the header skid shoes running on or off the ground.

To set the gauge correctly, raise the header until the skid shoes are just off the ground. Then, turn the screw (10) until the gauge needle is centred in the middle of the green indicator segment (9).

During field operation, the combine should then be operated with the needle remaining in the green zone (i.e. with the header skid shoes just off the ground). If the needle goes into the white area, raise or lower the header slightly.

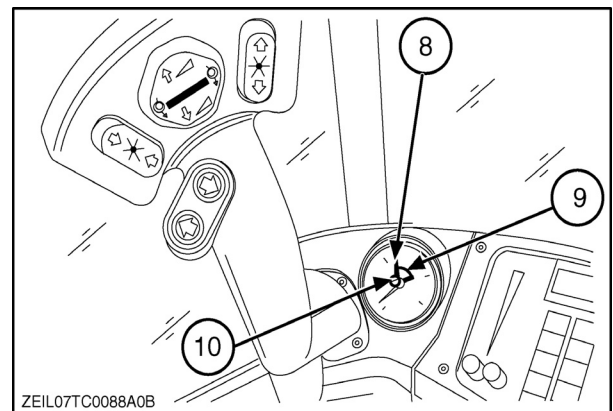

23

HEADER HEIGHT CONTROL

Perform the header height control calibration when changing the header (refer to paragraph "Header height calibrations") and the monitor calibration (item 7).

IMPORTANT: To enter an automatic header height control mode (compensation, Autofloat™ or stubble height), proceed as follows:

1. Engage the threshing mechanism
2. Select a mode
3. Give a pulse on the resume button (2).

The green autodiagnostic indicator (3) illuminates if the header is working in an automatic header height control mode with the pre-selected stubble height (Autofloat™ and stubble height) or pre-selected pressure (compensation).

To switch from one automatic mode to another, select the required operation mode with the selector switch (1) and give a pulse on the resume button (2) to enter the selected mode.

Manually operating header height control switch (5) always has priority of the selected automatic height control mode (compensation, Autofloat™ or stubble height) and will also disengage this automatic mode. Re-enter the automatic mode by giving a pulse on the resume button (2).

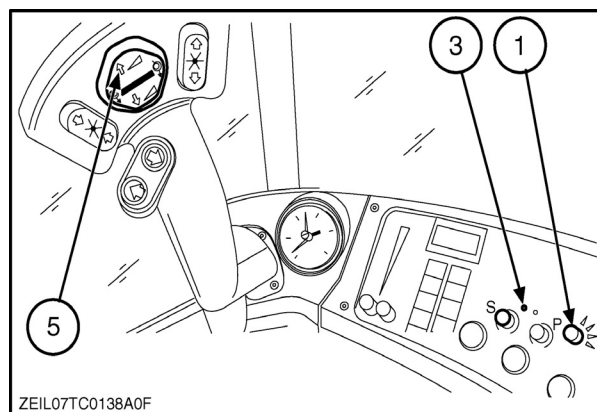

24

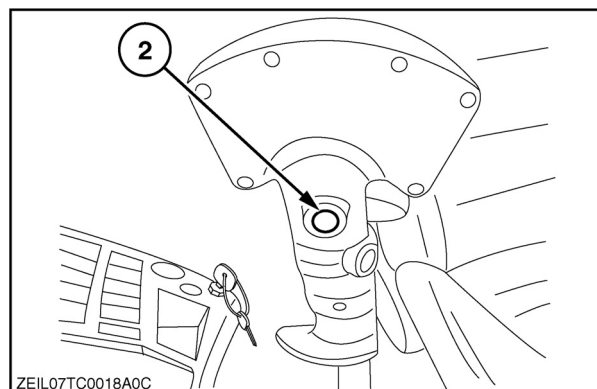

25

OPERATION MODES

With the header control selector switch, four different operation modes are possible:

- 1. Transport operation = Manual
 - 2. Compensation operation
 - 3. Stubble height operation
 - 4. Autofloat™ or Controlfloat™ operation
- } = Automatic header height controls

IMPORTANT: Before entering an automatic header height control mode (compensation mode, stubble height, Autofloat™ or Controlfloat™), do first the calibrations.

Refer to headed: "HEADER HEIGHT CONTROLS CALIBRATIONS" in this paragraph.

Transport operation

ALWAYS use this mode for road transport, attaching and detaching the header.

This mode is automatically selected when:

- Straw elevator is not engaged.
- Road mode is selected.
- Push on the header height rocker switch (5).

To use this mode, proceed as follows:

Turn the selector switch (1) in transport position and raise the header by pressing on the upper part of the header height control and header flotation (if applicable) rocker switch (5).

Lower the header by pressing on the lower part of the rocker switch (5).

Tilt down the left-hand side of the header by pressing on the left part of the rocker switch (5).

Tilt down the right-hand side of the header by pressing on the right part of the rocker switch (5).

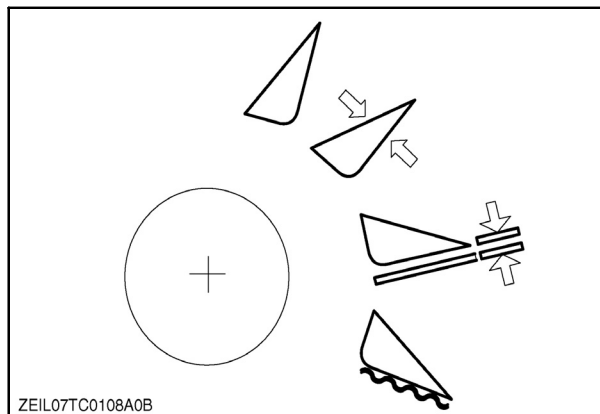

ZEIL07TC0108A0B

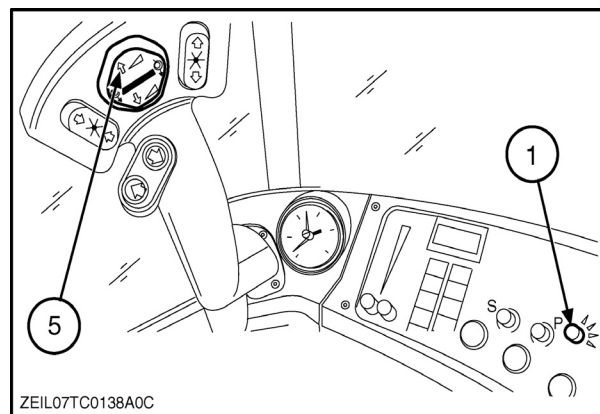

ZEIL07TC0138A0C

Compensation operation

Use this mode when harvesting peas and/or laid crops. In this operation mode, the header slides over the ground with a pre-selected pressure.

In this mode, it is also possible to obtain an **automatic lateral flotation** if Autofloat™ position sensors are fitted. The sensors should be connected to the combine and the outer header skids should be in pivoting position (i.e. hanging loose).

Turn the selector switch (1) as shown in fig. 28. Give a pulse on the resume button (2). The header lowers automatically at the pre-selected pressure when the threshing mechanism is engaged. After pressing the resume button (2), the green autodiagnostic indicator (3) starts blinking and remain so to show the compensation operation is engaged.

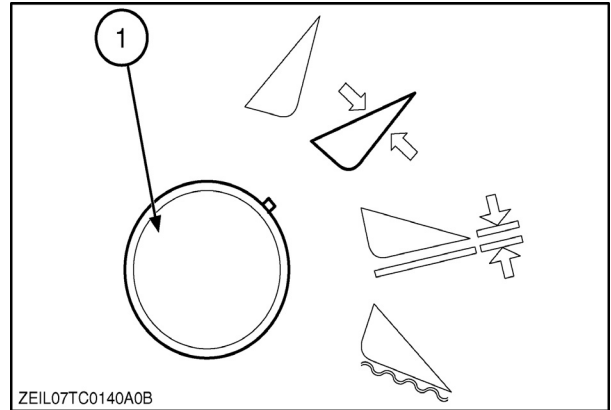

28

While harvesting, it is possible to change the pre-selected pressure by means of the header compensation knob (6).

Turn the knob (6) counter-clockwise (+) to increase the header pressure onto the soil.

Turn the knob (6) clockwise (-) to reduce the header pressure onto the soil.

Operating the header height control rocker switch (5) (vertical) disengages the compensation system into the transport mode [priority]. The green autodiagnostic indicator (3) will extinguish.

A pulse on the resume button (2) will bring the header back to the compensation operation mode.

When setting compensation, it can maximum be set at 108% of the header weight, which means that the header will start to raise.

When setting, this height, the header will not always follow the ground contour when passing an obstacle. In this case, it has to be set slightly heavier.

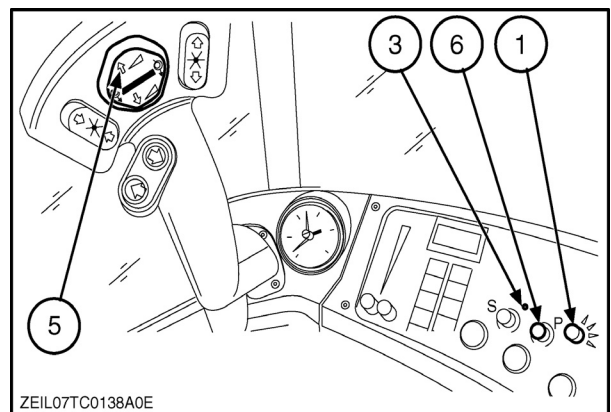

29

Autofloat™ or Controlfloat™ operation

[if sensors are fitted]

The header will follow the field contour at a pre-selected stubble height. Use this mode when a short stubble is required.

The **automatic compensation** is built in when touching the ground. Once the header clears the ground, it automatically returns to the pre-set stubble height.

Turn the selector switch (1) as shown. Give a pulse on the resume button (2) and the header will automatically lower to the pre-selected stubble height when the threshing mechanism is engaged.

The green autodiagnostic indicator warning light (3) illuminates to show that the header is operating at the pre-selected stubble height.

The pre-selected stubble height can be adjusted while harvesting by means of the header stubble height control knob (7).

Turn the knob (7) clockwise (+) to increase the pre-selected stubble height.

Turn the knob (7) counterclockwise (-) to reduce the pre-selected stubble height.

Operating the header height control rocker switch (5) vertically or sideways (lateral float) disengages the Autofloat™ or Controlfloat™ system completely into the transport mode. The green autodiagnostic indicator (3) extinguishes.

To return to the pre-selected stubble height and inclination, give a pulse on the resume button (2).

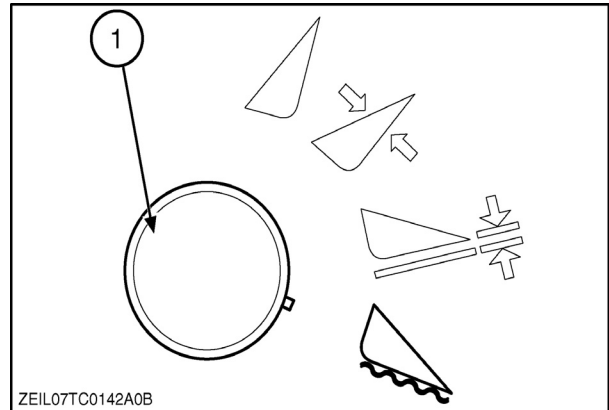

30

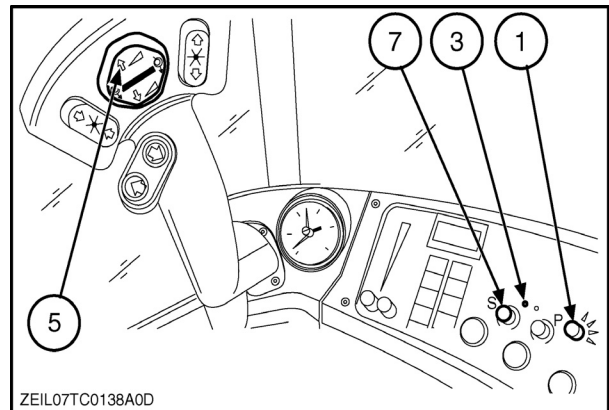

31

Stubble height operation

The header operates at a pre-selected stubble height. Use this mode when harvesting standing crops or when operating in stony conditions and at a higher stubble height.

In this mode the Autofloat™ sensors [if installed] are disengaged and the header can only be tilted manually by the rocker switch (5).

An **automatic compensation** is built in when touching the ground. After the header clears the ground, it automatically returns to the pre-set stubble height.

Turn the selector switch (1) as shown in fig. 32. Give a pulse on the resume button (2) and the header will automatically lower at to the pre-selected stubble height when the threshing mechanism is engaged. The green autodiagnostic indicator warning light (3) illuminates to show that the header is operating at the pre-selected stubble height.

The pre-selected stubble height can be adjusted during harvesting by means of the header stubble height control knob (7).

Turn the knob (7) clockwise (+) to increase the pre-selected stubble height.

Turn the knob (7) counter-clockwise (-) to reduce the pre-selected stubble height.

Operating the header height control rocker switch (5) vertically lowers or lifts the header into the transport mode [priority] . The green autodiagnostic indicator (3) extinguishes. To reenter the stubble height mode, give a pulse on the resume button (2).

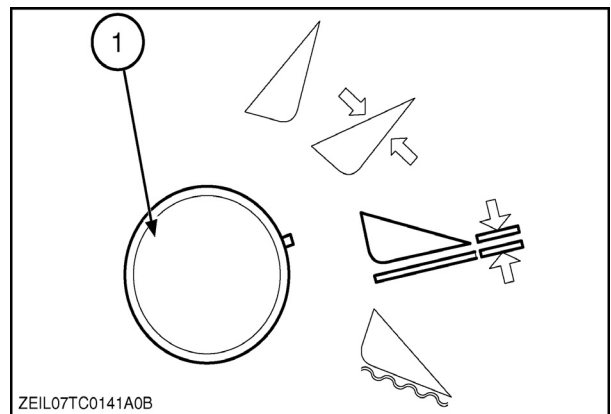

ZEIL07TC0141A0B

32

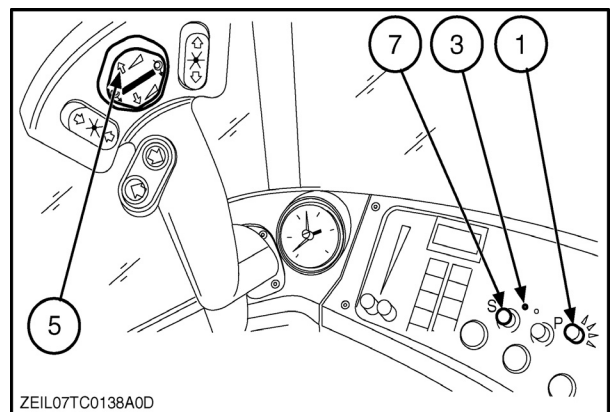

ZEIL07TC0138A0D

33

SECTION 3 – FIELD AND SITE OPERATION

Mode summary

HEADERS	CONDITIONS	Compensation	Stubble	Autofloat™ or Controlfloat™
Grain header	Standing crops Undersown conditions Green undergrowth	X		(X)
	Contact with the ground Badly laid crops, Peas, beans, etc.	X		
	Standing crops Good conditions		X	X
	Rape seeds (direct cut)		X	
	Rice crop		X	X
Maize header	All		X	

HEADER HEIGHT CONTROL CALIBRATION

Purpose

To obtain a correct functioning of the automatic header height control modes (compensation / stubble height / Autofloat™ or Controlfloat™ (if installed), three calibrations has to be performed:

- Ground level calibration
- Maximum cylinder pressure calibration
- Ground level calibration by the Autofloat™ sensors (if the Autofloat™ or Controlfloat™ system is installed)

Besides, it is necessary to perform the following calibrations:

- Before the first start-up
- When the wheel or header dimensions are changed
- When a header lifting cylinder is added
- When the system part replacement is required

To calibrate the automatic system, the appropriate header has to be attached and the outer header skids should be in pivoting system.

Perform two or three calibrations, one after the other.

Ground level calibration

1. Start the engine.
2. Select the transport position with the selector switch (1).
3. Lower and lift the header with the header height control rocker switch (5) at least once.
4. Lower the header with the header height control rocker switch (5) and make sure the header rests flat onto the ground.
5. Press the header height control rockers switch (5) (lower the header) and the resume button (2) simultaneously. Hold both switches until the green autodiagnostic indicator (3) has blinked five times.

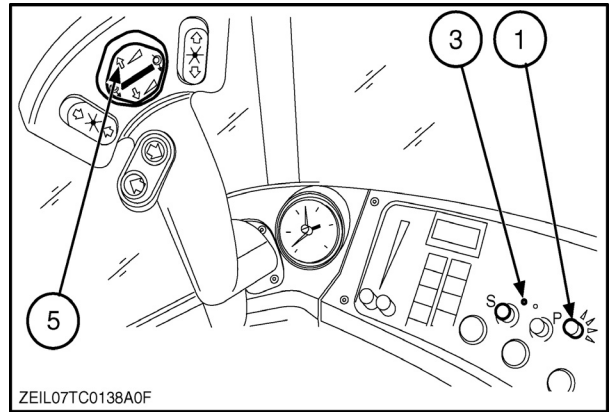

34

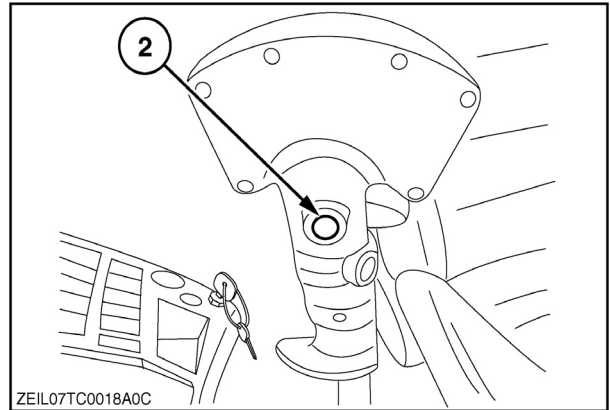

35

Maximum cylinder pressure calibration

1. Start the engine.
2. Select the transport position with the selector switch (1).

NOTE: Step 1 and 2 need not be carried out if this calibration is performed immediately after the ground level calibration.

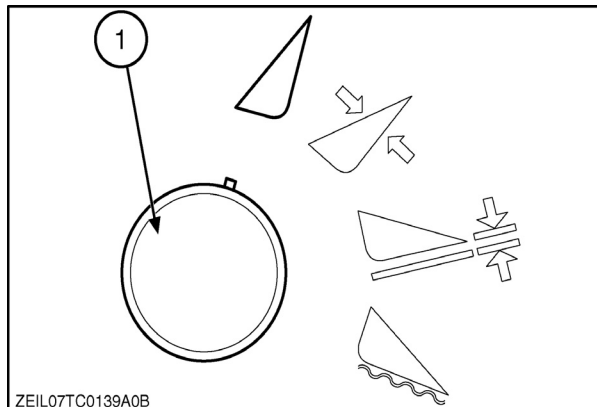

36

3. Lower and lift the header at least once with the header height control rocker switch (5).
4. Lower the header just above the ground level (the header must not touch the ground).

NOTE: Lowering the header must be the last operation.

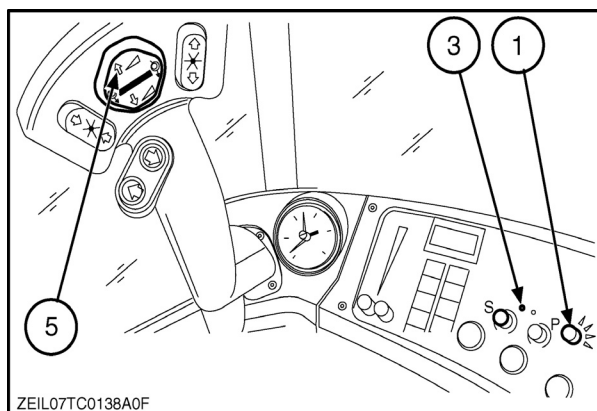

37

5. Press and hold the resume button (2) for 7 seconds, without touching other switches, until the green indicator (3) has blinked eight times.

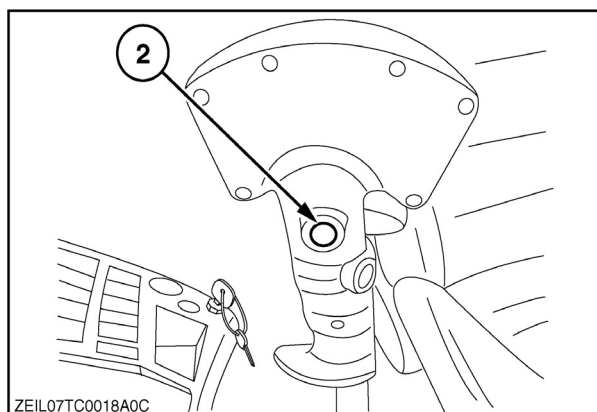

38

Ground level calibration through the Autofloat™ sensors

NOTE: Make sure the Autofloat™ sensors are connected.

1. Make sure the header outer skid shoes are in swinging position (i.e. hanging loose).
2. Start the engine.
3. Select the transport position with the selector switch (1).

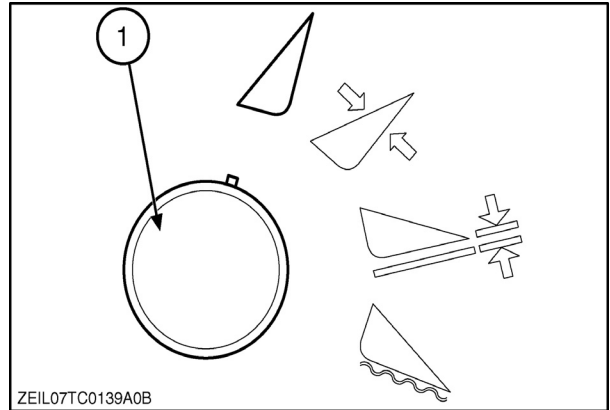

39

4. Lower and lift the header at least once with the header height control rocker switch (5).
5. Lower the header with the header height control rocker switch (5) and make sure the header rests flat onto the ground. If not, adjust the inclination with the rocker switch (5).
6. Check if the Autofloat™ sensors are operating.
7. Press the resume button (2) and simultaneously lift the header slowly (First speed level) with the header height control rocker switch (5). Keep both switches pressed (with header in highest position) until the green autodiagnostic indicator (3) has blinked ten times.

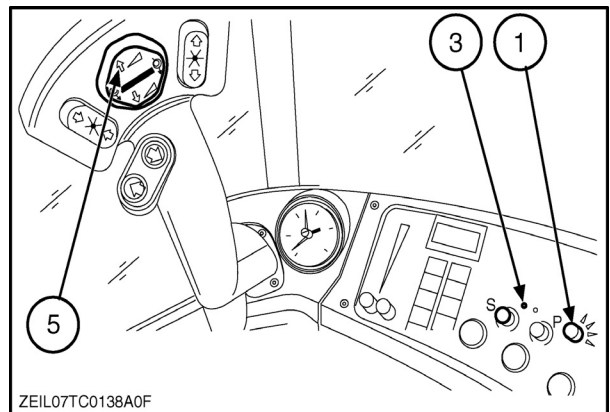

40

NOTE: If the item 7 is not successful, repeat it with the switch (5) (pressing briefly = quick lifting and lowering)

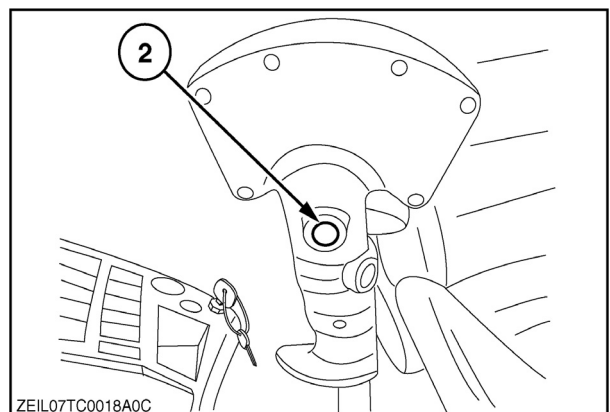

41

Auto-diagnostics

The blinking sequence of the red autodiagnosics control light (4) identifies an error message.

The blinking sequence always consists of two periods separated by a short interval. Then, after a longer interval the blinking sequence will repeat again.

The first period indicates the first digit of the error message, the second one indicates the second digit.

For example

Error message 23

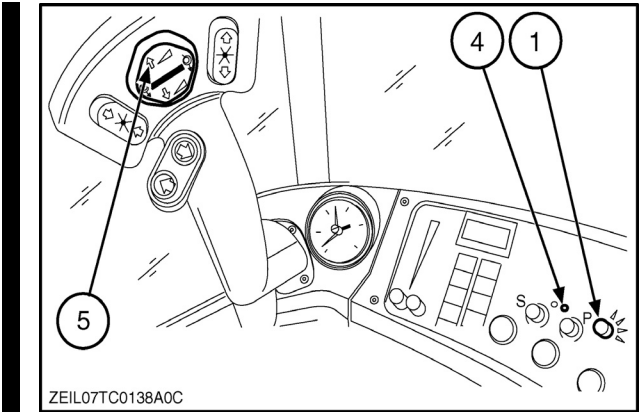

42

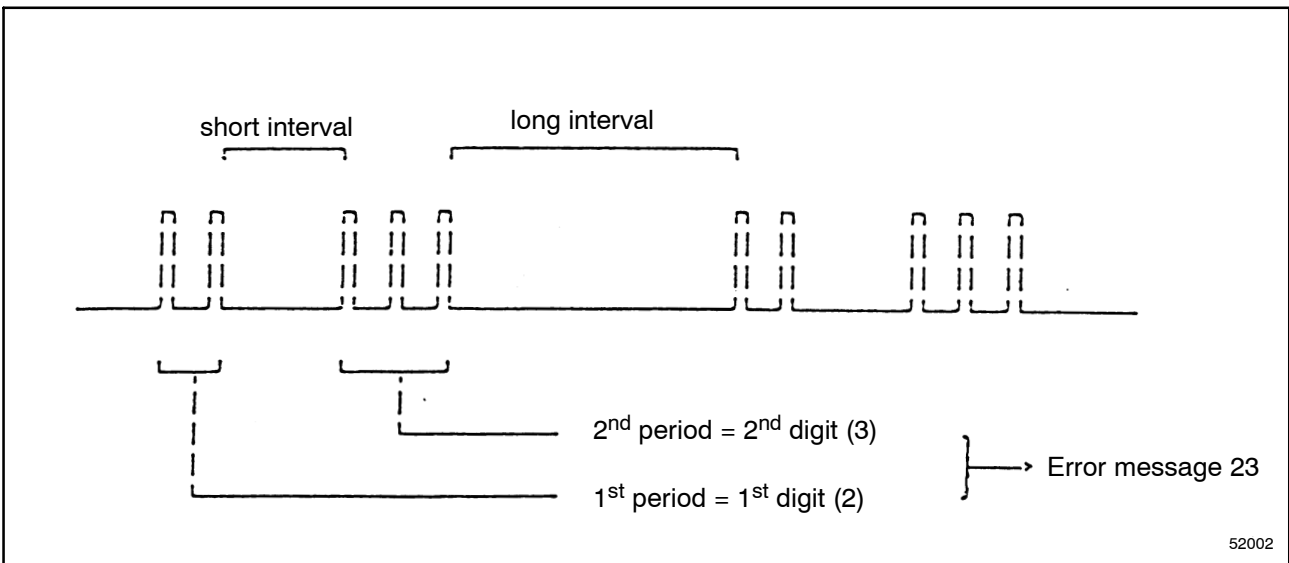

43

NOTE: A list with error messages is mentioned in SECTION 5 – FAULT FINDING: “Header height control – Error messages”

STRAW ELEVATOR

Straw elevator adjustment

The lower shaft 1 of the straw elevator is spring-tensioned so that it can float according to the amount of material being harvested.

The spring tension 2 must be adjusted according to the crop being harvested.

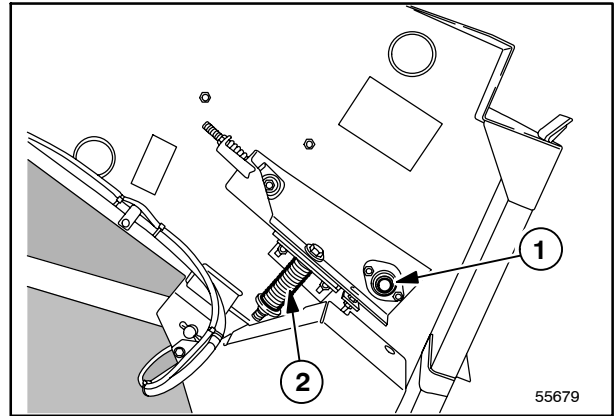

44

• **Models without lateral flotation**

For all crops other than maize, both shaft sides must be adjusted as follows:

1. The stops 4 must be positioned in the lowest position.
Loosen the nuts 3 and the nut 7 and ease off the bolt 6 until the minimum distance of 1 mm between the plate 5 and the bolt 6 is obtained.
2. Tighten the nuts 3 and 7.
3. Adjust the spring length 2 by the nut 11 to a length of 112 mm.

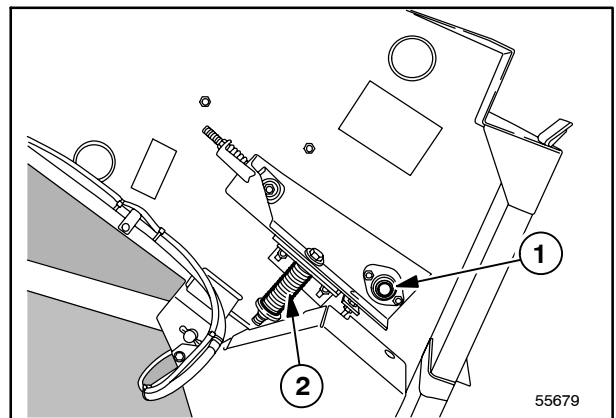

45

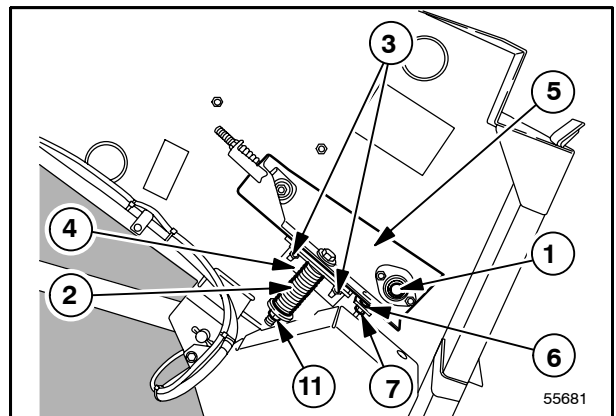

46

• **Models with lateral flotation**

For all crops other than maize, both shaft sides must be adjusted as follows:

1. The stops 4 must be positioned in the lowest position.
Loosen the nuts 3 and the nut 7 and ease off the bolt 6 until the minimum distance of 1 mm between the plate 5 and the bolt 6 is obtained.
2. Tighten the nuts 3 and 7.
3. Adjust the spring length 2 by the nut 11 to a length of 112 mm.

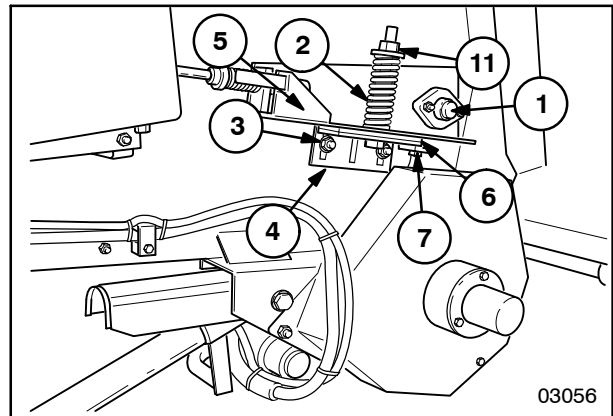

47

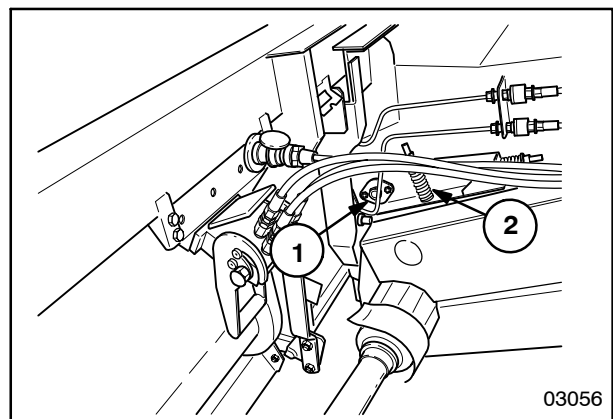

48

Adjustment for harvesting maize
(with or without lateral flotation)

1. Brings the stops 4 in the highest position.
2. Loosen the nuts 3 and the nut 7 and tighten the bolt 6.
3. Move the stop 4 against the support 5 and tighten the nut 3.
4. Loosen the screw 6 until the minimum distance of 1 mm between the support 5 and the bolt is obtained.
5. Tighten the nut 7.
6. Adjust the spring 2 with the nut 11 to a length of 89 mm.

Straw elevator

Removal

CAUTION

- Be careful when doing this job as the straw elevator weighs about 800 kg and the hydraulic cylinders are heavy.
- Ensure the battery key is in the “OFF” position.
- Always keep the header attached to the straw elevator.
- Use suitable jack stands, securely positioned underneath the straw elevator bottom, before reversing the combine.
- When the header is in high position, use always the red mechanical security on the left cylinder.

Proceed as follows:

1. At the left side (PTO side), remove the protection cover (2) by loosening the two quick release bolts (1).
2. Disconnect the hydraulic hoses (3) from the header.
3. If lateral flotation is installed, disconnect the hoses (4).

IMPORTANT: Avoid possible oil contamination by properly fitting the blanking plugs (5) into the hydraulic quick couplers.

4. Lower the header onto the ground.

5. Support the straw elevator with suitable jack stands.
6. Disconnect the power cable from the reverser motor by loosening the nut (1) and the screw (2).

NOTE: The two cables are in the same loom.

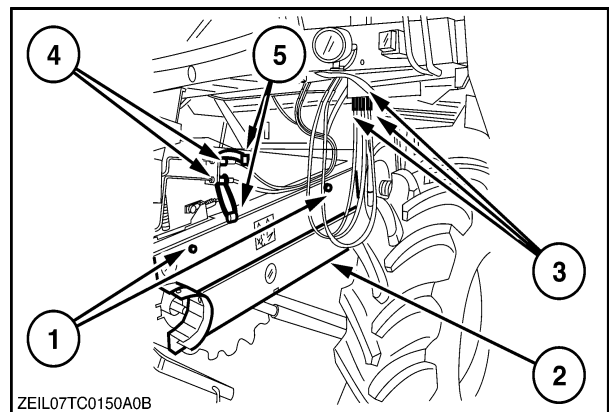

49

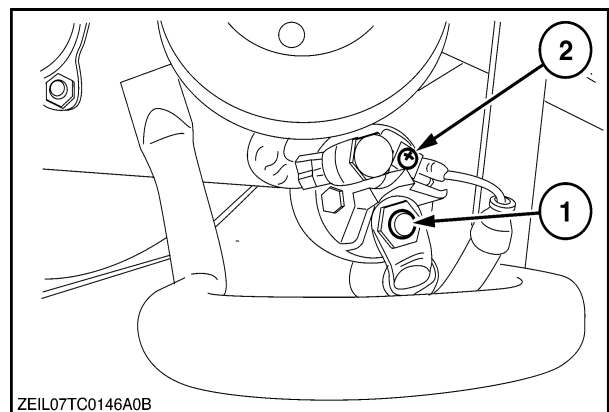

50

7. Remove the power cable (3) from the straw elevator by loosening the three bolts (1) and the bolt (2).

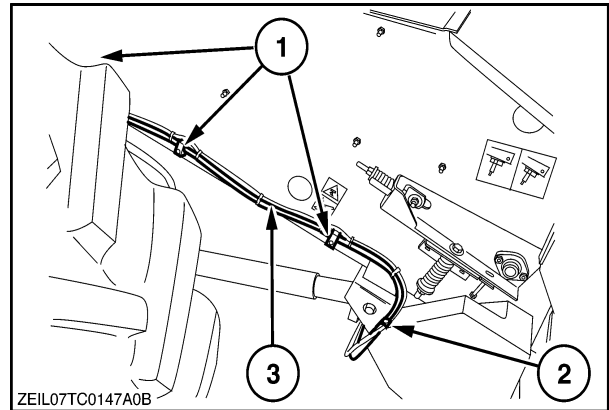

51

8. Disconnect the earth connection cable (1) and release the chain (2) from the straw elevator (3).

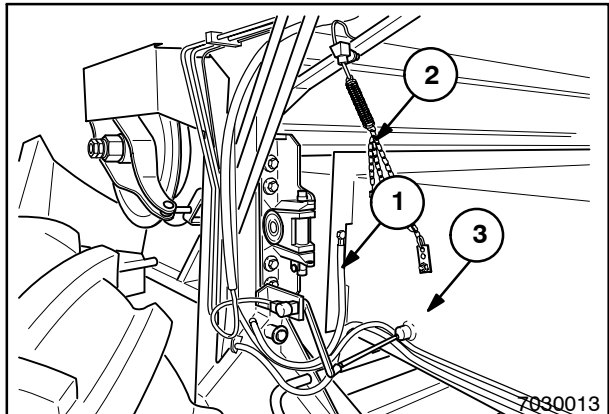

52

9. On both sides loosen the bolt (4), the key (5) and bracket halves (6).

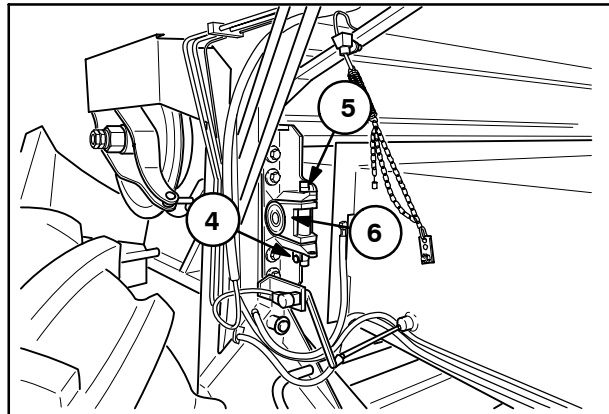

53

10. Remove the belt (2) from the pulley (1).



Be sure that the belt (2) is over the pulley axle (3), otherwise the straw elevator will be stuck when reversing the combine.

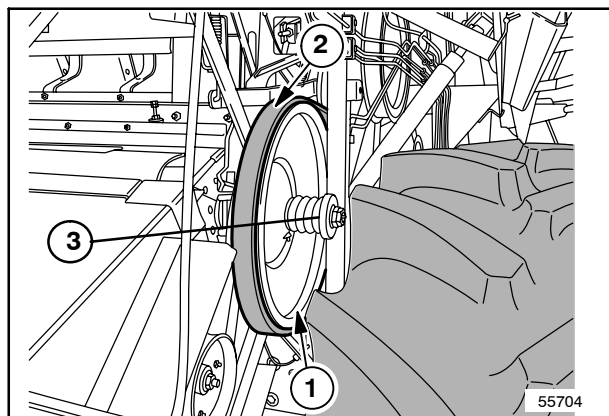

54

SECTION 3 – FIELD AND SITE OPERATION

11. On both sides remove the cotter pins (3) and washer (2).

12. Remove the axle (4) towards the inside.



Use wooden blocks to prevent the fall of the cylinders (1) when reversing the combine.

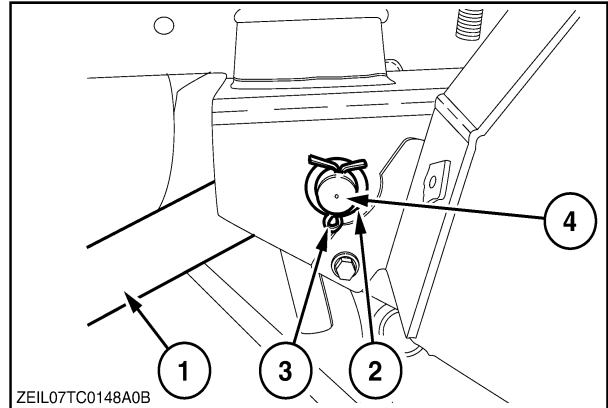

55

13. Reverse the combine approximately 1.5 m backwards.

14. Now you have access to the drum.

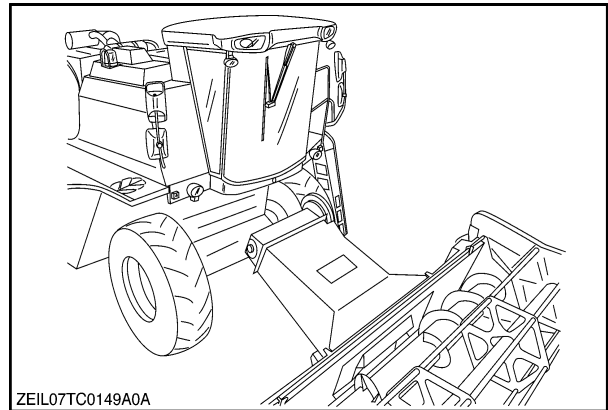

56

Installation

1. Move combine slowly forwards to install the straw elevator, secure with the bracket halves (6), the key (5) and the bolt (4).

WARNING

Be sure that the belt (2) is over the pulley axle (3) when you move forwards.

2. On the left hand side, lift the hydraulic cylinder (1), place the safety latch (3) and pass the axle (4) with the bushes (2) as shown.

3. Install the washer and secure with a new cotter pin.

4. On the right hand side, lift the hydraulic cylinder (1) and pass the axle (4).

5. Install the washer (2) and secure with a new cotter pin (3).

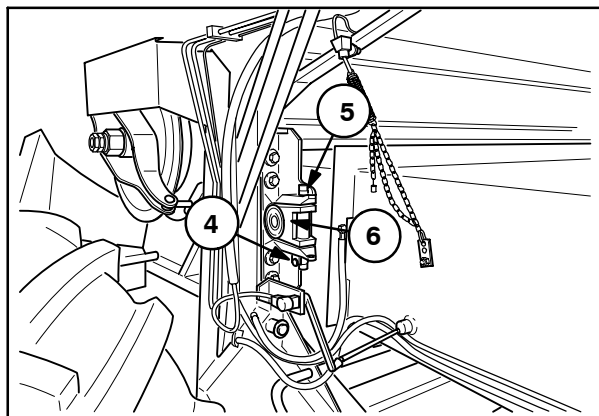

57

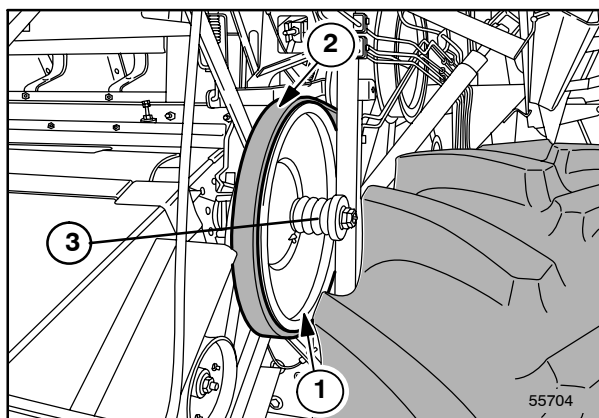

58

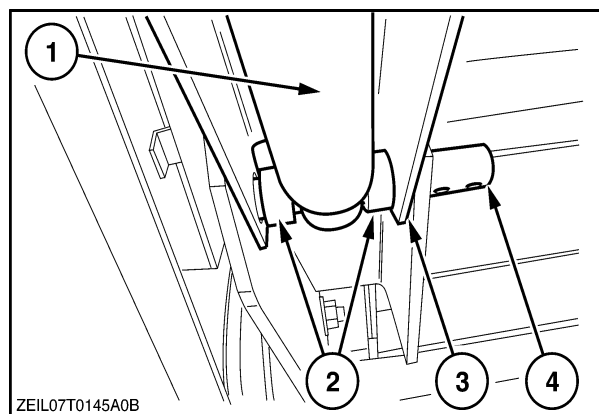

59

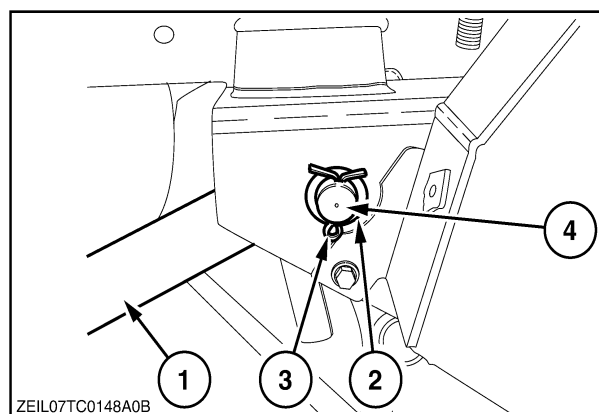

60

SECTION 3 – FIELD AND SITE OPERATION

6. Attach the power cable (3) on the straw elevator with the three bolt assemblies (1) and the bolt (2).

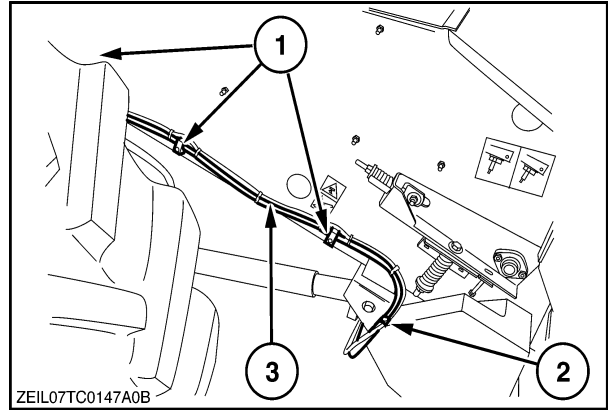

61

7. Connect the power cable to the reverser motor with the nut (1) and the screw (2).

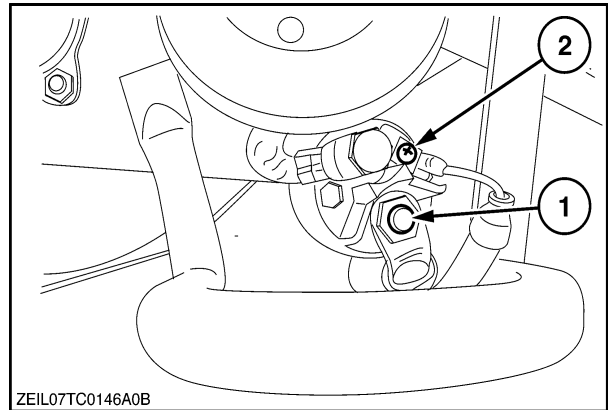

62

8. Connect the earth connection cable (1) and attach the chain (2) on the straw elevator (3).

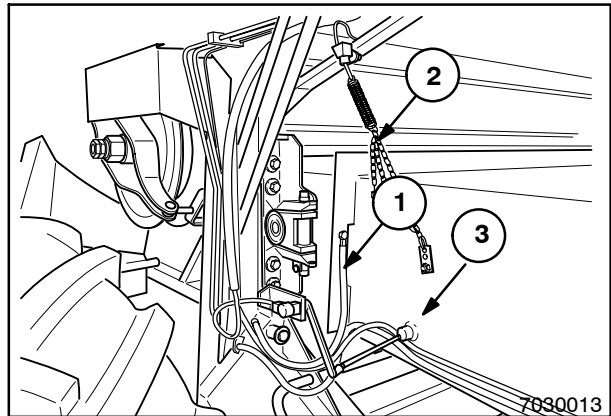

63

9. On the left side connect the hydraulic hoses (4) (if lateral flotation is installed).

10. Install protection cover (2) with the two quick release bolts (1).

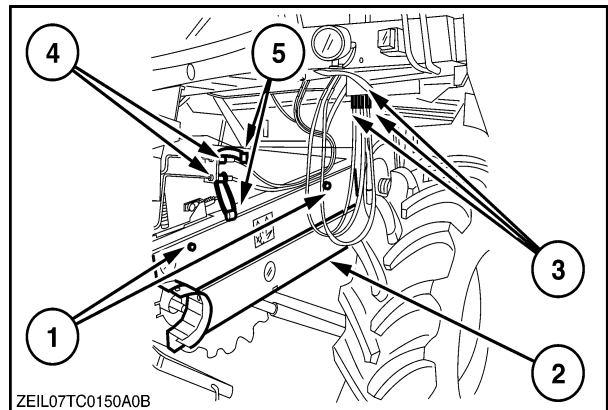

64

Drum concave

Removal

1. Remove the straw elevator, refer to “Straw elevator – removal”.
2. Remove the anti-dust plate (3).
3. Remove the bolts (1) to release the support (2).

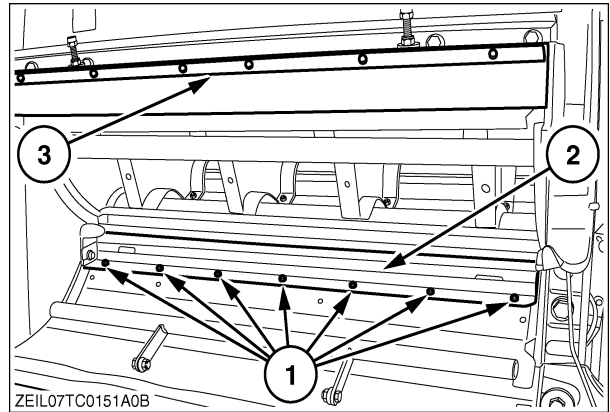

65

4. Loosen the four bolt-plate assemblies (5) to release the stone trap (6).

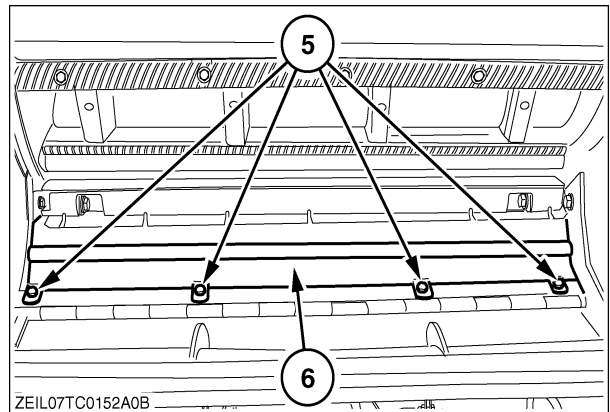

66

5. Loosen the bolts (7) to release the metal strip and the rubber canvas (8).

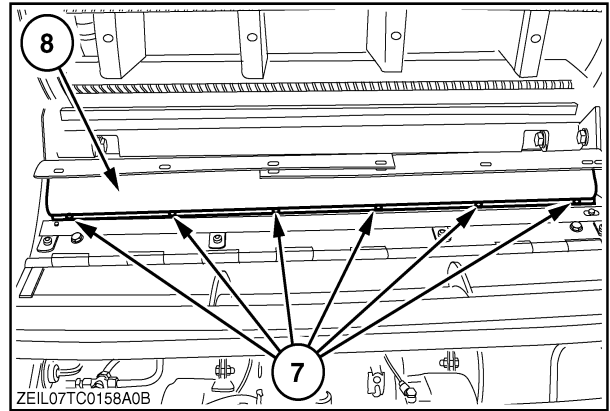

67

6. On both sides, remove the two bolts (2) to release the supports (1).

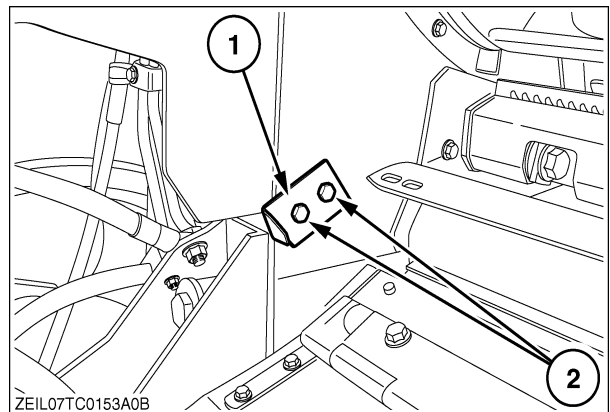

68

SECTION 3 – FIELD AND SITE OPERATION

7. Insert two wooden blocks (1).
8. On both sides, loosen the bolt (3) to release the front of the concave.

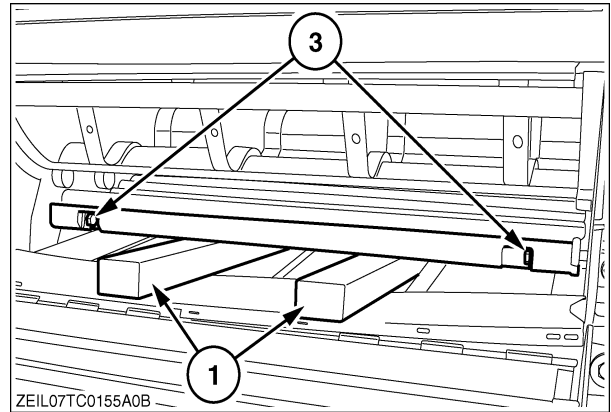

69

9. On both sides, remove the grain pan access covers (18) by loosening the three wing nuts (21).

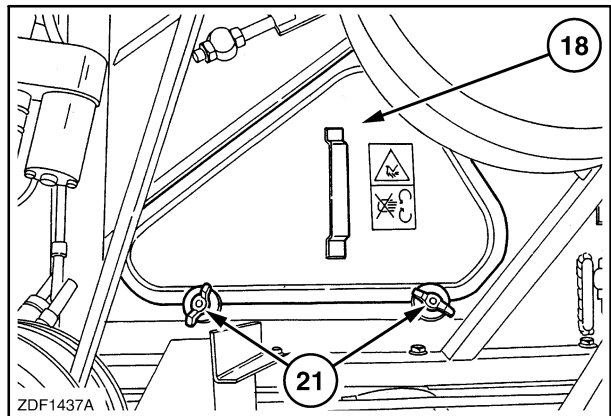

70

10. Loosen the nuts (1) to remove the rake (2) and the plate (3).
(Access through the straw walker opening).

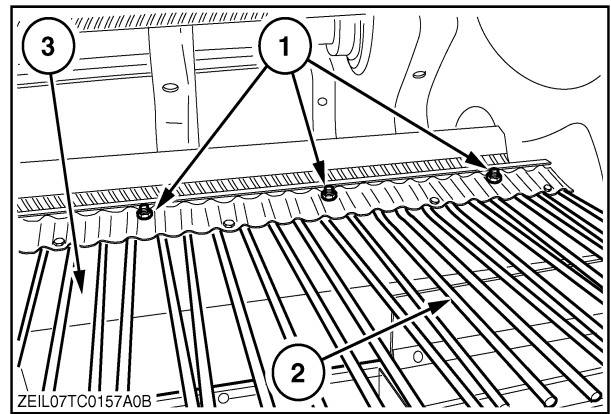

71

11. On the inside, loosen the bolts (3) to release the back of the concave (2).

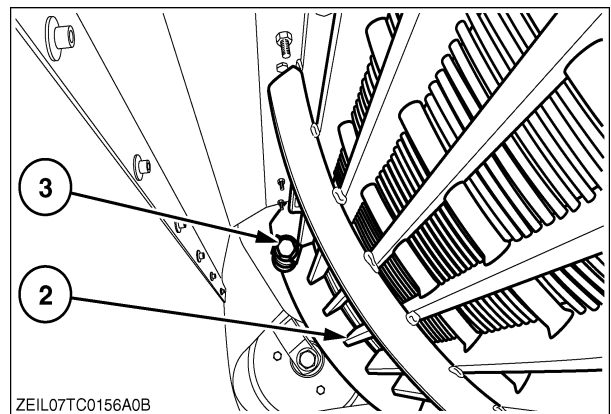

72

SECTION 3 – FIELD AND SITE OPERATION

12. On both sides, remove the nuts (4), front and rear.

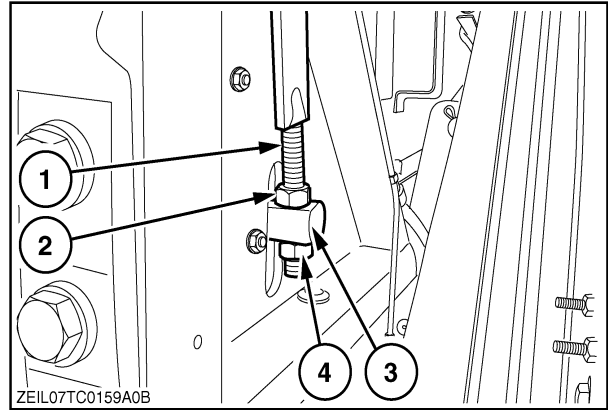

13. This detail of figure 73 gives you a better idea of the mechanism.
The front (A) of the axle (3) passes through the combine and then in the concave where it is secured in place with a bolt (3) and washers (see fig. 68 and fig. 71).
The head (B) is used as a pivot and to secure the treaded rod.

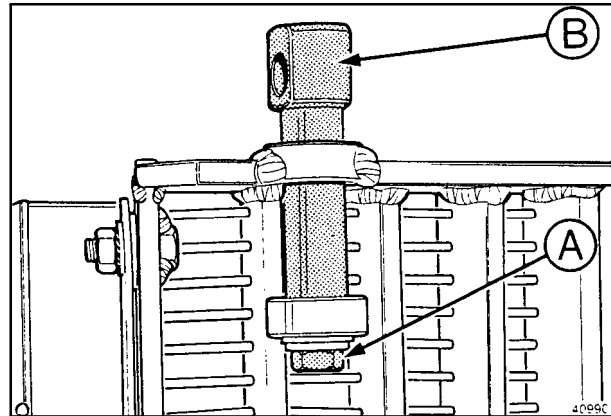

14. Adjust the concave in highest position by using the lever on the steering platform.
15. On both sides, remove the axles (3) (front and rear).
16. Roll the concave from under the drum.
17. Perform a visual check for defects or cracks.

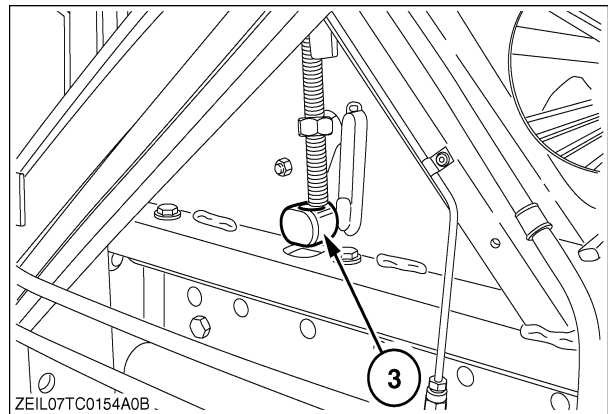

Installation

1. Insert wooden blocks (1).
Place the concave on the blocks.
2. Attach the concave on the drums with ropes.
3. Turn the drum with the drum socket wrench (2) to lift the concave back in place.
4. The drum socket wrench (2) is located on the right-hand side of the engine platform ladder.
5. Turn the drum clockwise until you can pass the axle (3) through the front holes.
6. Remove the ropes, access through grain pan access covers (see fig. 70).

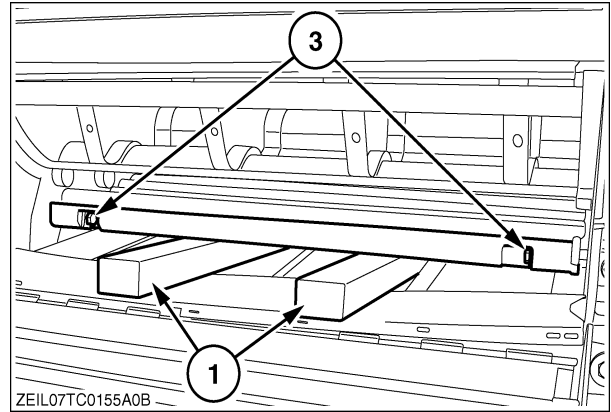

76

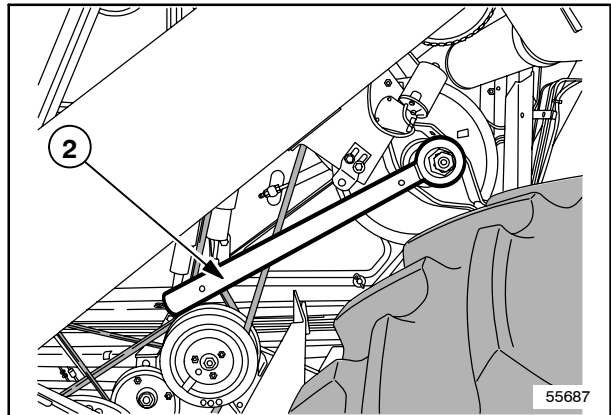

77

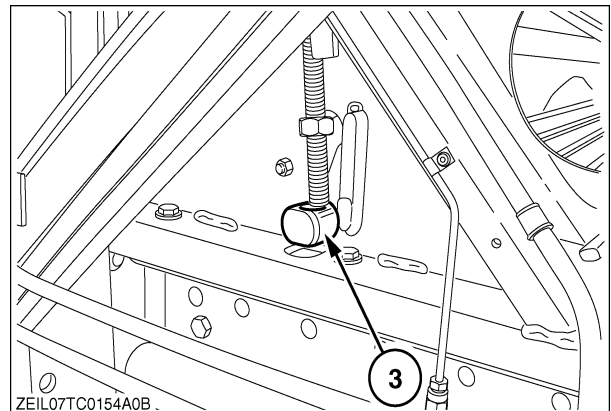

78

SECTION 3 – FIELD AND SITE OPERATION

- Pivot the concave (2) over the front axles until you can pass the rear axles (3).

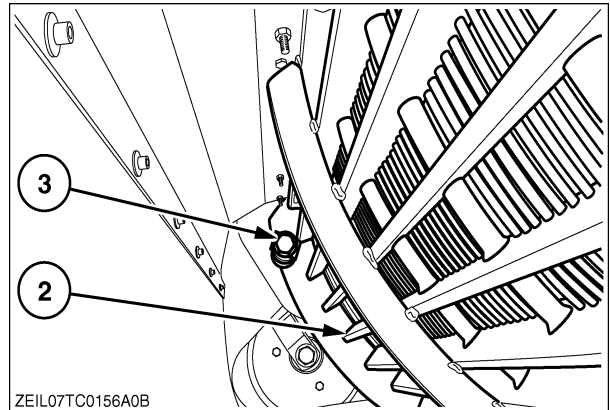

79

- Pass all the treaded rods (1) through the axles (3) and install the nuts (4).

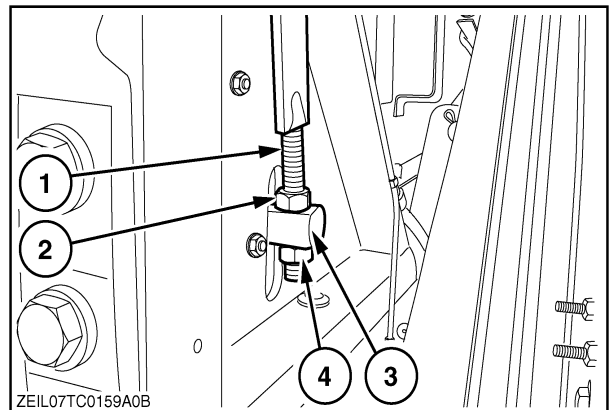

80

- Tighten the bolts (3) (front and rear).
- Lift the concave by using the lever on the steering platform and remove the wooden blocks (1).
- Check the distance between concave and drum. If necessary readjust with the nuts (2) and (4) (fig. 80).

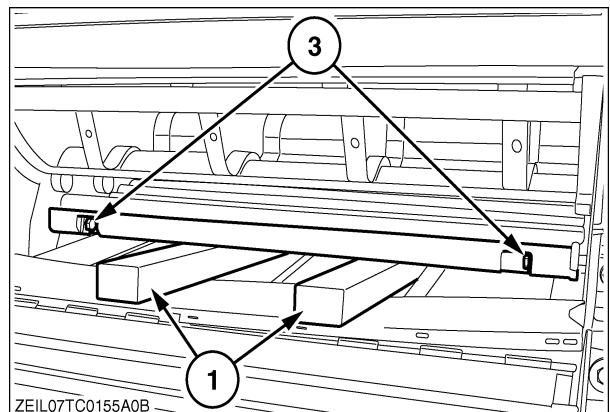

81

- Install the rubber canvas (8) and the metal strip with the bolts (7) on the support (2) (see fig. 84).

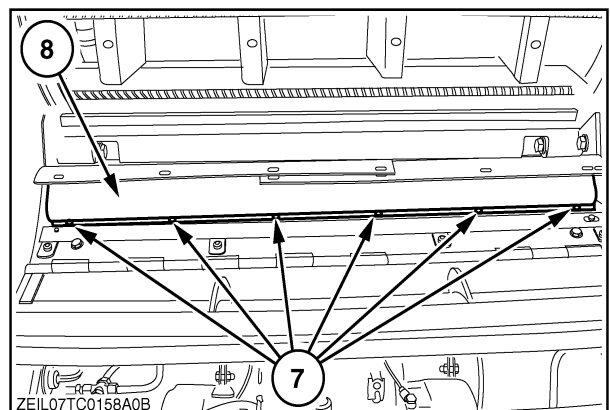

82

SECTION 3 – FIELD AND SITE OPERATION

13. On both sides, install the two supports (1) and tighten with the nuts (2).

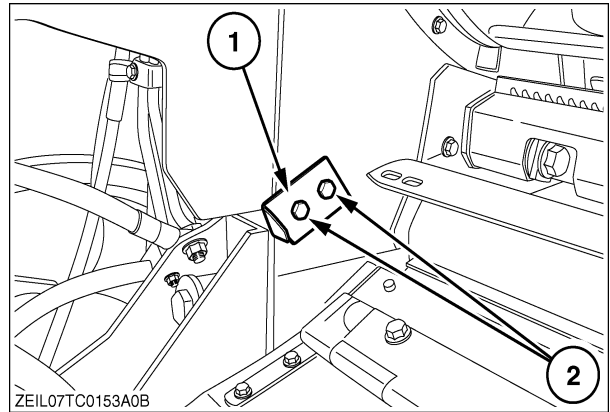

83

14. Install the support (2) and tighten with the bolts (1).

15. Install the anti-dust plate (3).

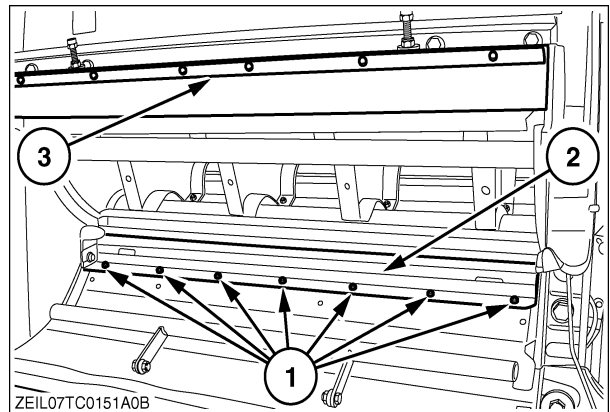

84

16. Install the stone trap (6) and tighten with the four bolt-plate assemblies (5).

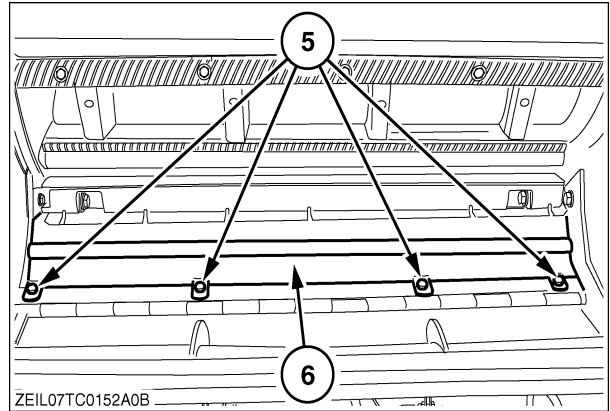

85

17. Install the rake (2) with the plate (3) and tighten the nuts (1) (access through the straw walker cover).

18. Install the grain pan access covers (fig. 70).

19. Install the straw elevator, refer to "Straw elevator – installation".

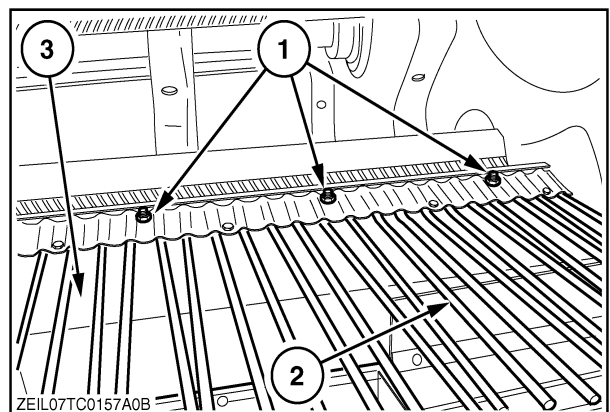

86

STONE TRAP

The stone trap must be cleaned out at least once a day and more frequently in case of wet crop or stony ground conditions.



CAUTION



Disengage the threshing mechanism, lift the straw elevator to its maximum height, place the header safety latch over the cylinder rod, stop the engine and engage the parking brake.

To clean the stone trap, move the lever 10 upwards, to open the cover 11 of the stone trap. After the complete cleaning of the stone trap, move the lever 10 completely downwards to close the cover 11 again.

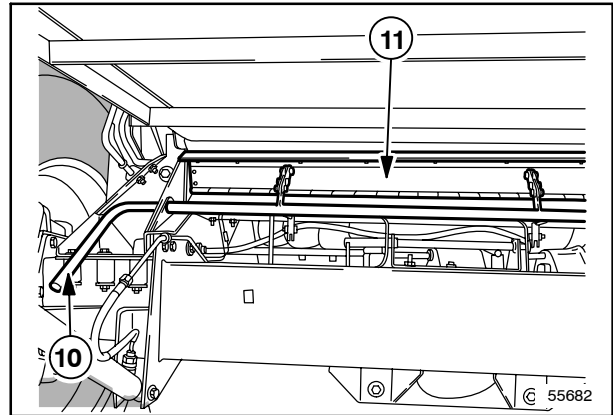

87

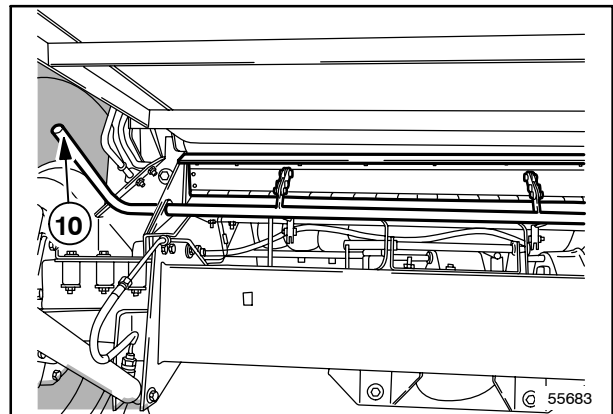

88

IMPORTANT: In case of rice harvesting, it is necessary to remove the tube inside the stone trap to fit the cover plate on the stone trap.

ANTI-DUST PLATE

In case of maize harvesting, the anti-dust plate 1 and the anti-wrap shields 2 must be removed.

Proceed as follows:

1. Remove the straw elevator (refer to paragraph headed "Straw elevator removal").
2. Remove the cover 3 by turning the three levers 4 a quarter of a turn.
3. Remove the four nuts 5, so that the plate 6, to which the anti-dust plate 1 is fitted, can be taken out.
4. Loosen the lock nut 7 and the nut 8 on both sides.
5. Remove the bolt 10 and the self-locking nut. Make sure not to lose the springs inside the bushings.
6. Remove the rod 11 (fig. 89) and the anti-dust plate 1.
7. Reinstall the plate 6 and tighten fully the openings on both sides.
8. Reinstall the cover 3 and the straw elevator.

To reinstall the anti-dust plate, proceed in reverse order of the disassembly sequence and adjust nuts 8 until a clearance of 3 mm is obtained between the plate and the drum rasp bars.

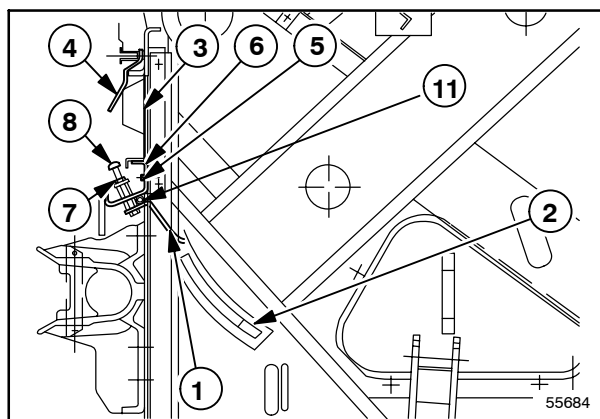

89

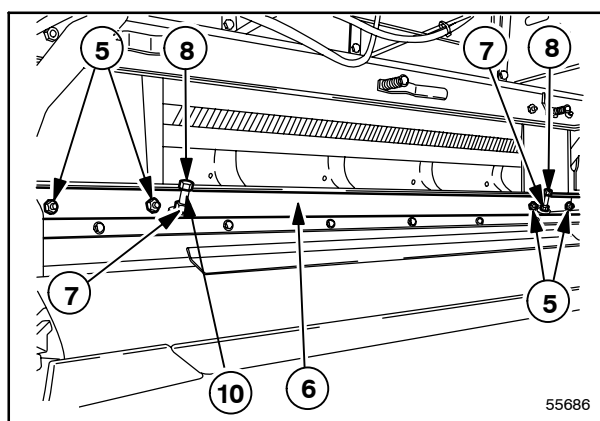

90

ACCESS TO THE GRAIN PAN

To gain access to the grain pan, proceed as follows:

1. Open the stone trap as described in the previous paragraph and flip over the tube in the stone trap.
2. Loosen the five screws 13 until the square washers 14 can be removed from the plate 16.
3. Lift slightly the plate 16 and move it forward as much as possible.
4. To install the plate 16 proceed in reverse order.
5. Close the stone trap.

To gain access at the sides, refer to paragraph "Access to the drum and to the concave", further in this Section.

IMPORTANT: It is necessary to keep the grain pan clean while harvesting maize.

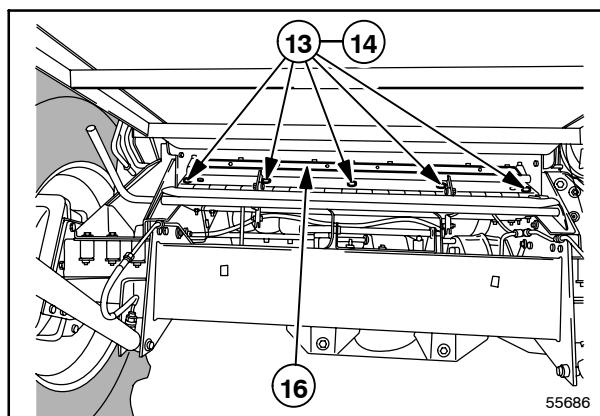

91

DRUM AND CONCAVE

ADJUSTMENT VALUES

The adjustment values of the drum rpm and of the concave clearance depend on the following factors:

- Crop type to be harvested
- Crop maturity and variety
- Humidity content
- Volume of straw and grain
- Weed contamination

FUNDAMENTALS OF ADJUSTMENT

- Maximum drum speed and minimum concave clearance, give maximum threshing efficiency.
- If the grain is damaged excessively, it is necessary to reduce the drum speed. If straw is damaged too much it is necessary to increase concave clearance.
- If straw is damaged too much it is necessary to increase concave clearance.
- If grain is not fully separated from the ears, increase the drum speed and/or reduce the concave clearance.
- If plugging or wrapping occurs, increase the drum speed.

DRUM SPEED

The drum speed is adjustable electrically from the operator's platform and can be read on the display.

IMPORTANT: Actuate the drum speed adjustment rocker switch only with the threshing mechanism running.

ACCESS TO THE DRUM AND TO THE CONCAVE



CAUTION



Before opening the guard, stop the engine, remove the ignition key and engage the parking brake.

Access from the front

Turn the three levers 22 a quarter of a turn to take out the front plate.

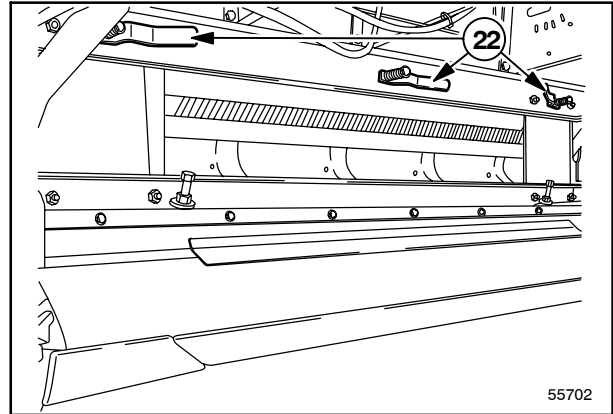

92

Access from the left-hand side

Loosen the eccentric shaft idler 19 by turning the lever 20.

Lower the idler 19 downwards.

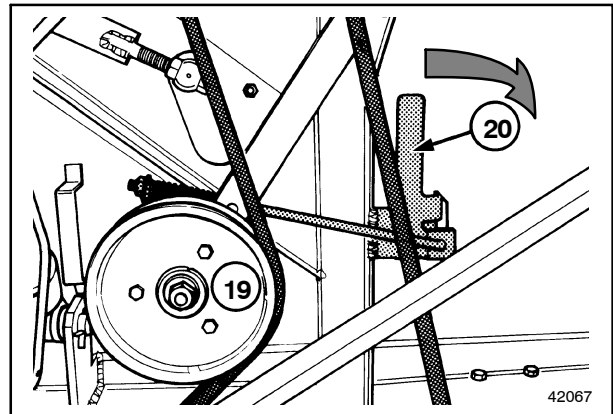

93

Remove the three wing nuts 21 to take out the cover 18.

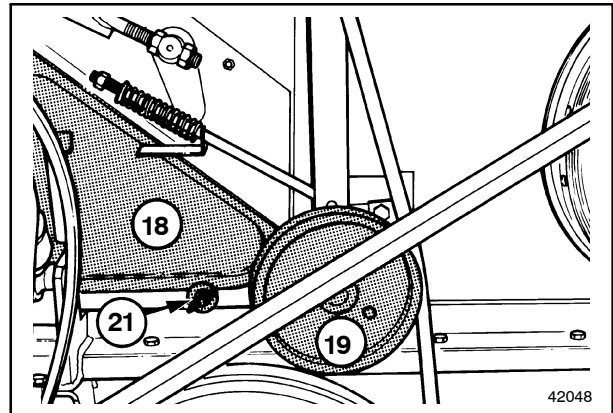

94

Access from the right-hand side

To remove the cover 18 remove the three wing nuts 21.

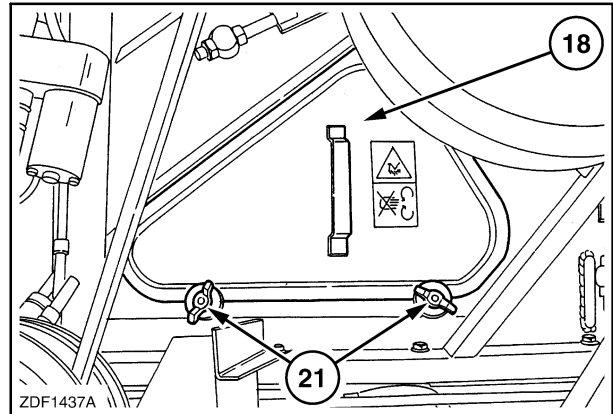

95

DRUM BLOCKAGE

Should the drum become blocked, proceed as follows:

1. Lower the concave completely and try to unblock by engaging the threshing mechanism at engine low idle.
2. If this is not enough, try to unblock the drum by using the drum socket wrench 1. The drum socket wrench 1 is located on the right-hand side of the engine platform ladder.

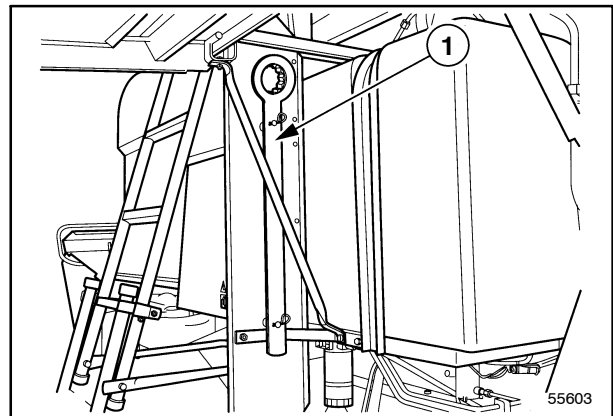

96

Install the drum socket wrench 1 onto the drum sheave and turn counter-clockwise to unblock the drum.

Remove the wad of material or stone through the stone trap.

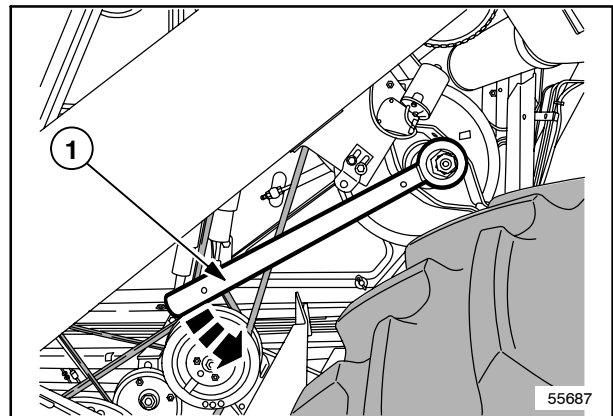

97



CAUTION



Before unblock the drum, stop the engine, remove the ignition key and engage the parking brake.

CONCAVE CLEARANCE

- Adjustment from the Operator’s seat:
By means of the control lever
(refer to SECTION 2 – CONTROLS,
INSTRUMENTS AND OPERATION).
- Mechanical adjustment: refer to paragraph
headed "Changing the clearance mechanical"
further in this section.

Basic settings

When the combine is shipped from the factory,
concave 3 is set parallel to the drum 4 as follows:

- CEREAL CONCAVE
The concave control lever in 2nd position
Front distance: 10 mm on the 2nd bar
Rear distance: 10 mm on the 13th bar

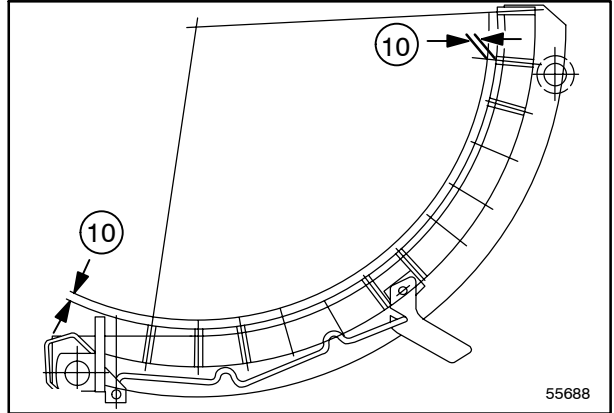

98

- MAIZE CONCAVE
The concave control lever in 7th position
Front distance: 25 mm on the 1st bar
Rear distance: 31 mm on the 8th bar

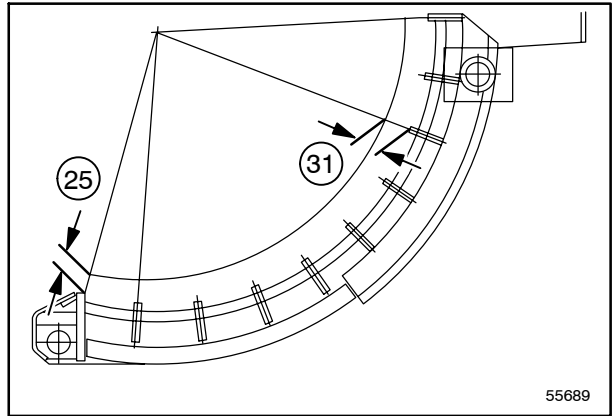

99

- RICE CONCAVE
The concave control lever in the 4th position
Front distance: 20 mm on the 1st bar
Rear distance: 25 mm on the 4th bar

These concave settings will be satisfactory for most
crops. However, if greater threshing action is needed,
the clearance at the rear can be reduced.
In excessive grain damage is experienced, increase
the concave clearance.

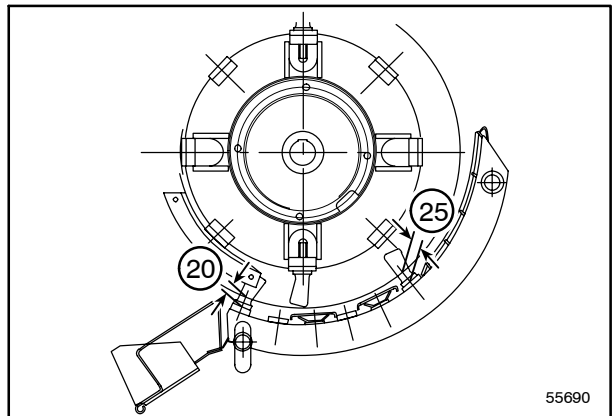

100

Concave clearance mechanical adjustment

To change these factory settings, proceed as follows:

1. Place the concave control lever in its second position on the quadrant (refer to the previous paragraph).
2. To change the concave front position, position the nut 1 on both concave sides.
3. To change the concave rear position, position the nut 2 on both concave sides.
4. Measure the concave clearance – see explanation in the previous paragraph.

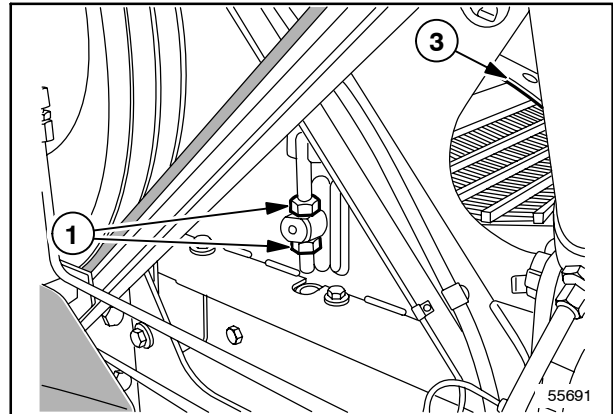

101

5. To measure the concave clearance, remove the guards 3.

CAUTION

Before starting the adjustment operations and before opening the guards, stop the engine, remove the ignition key and engage the parking brake.

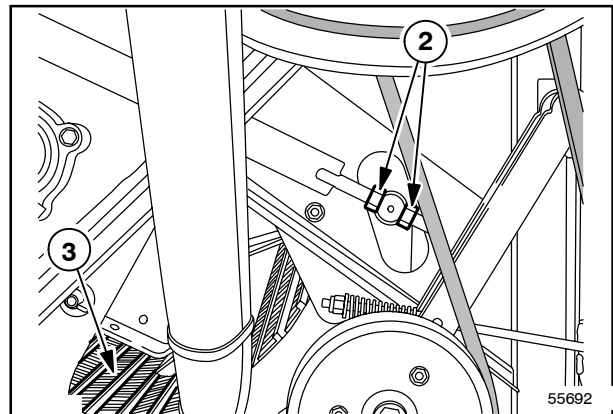

102

IMPORTANT: After carrying out the adjustments to the concave, ensure that the concave rub bars are set parallel to the drum rasp bars.

Concave position for harvesting maize

When harvesting maize, the concave can be set to a clearance of 25 mm on the first concave rub bar and 31 mm on the eighth concave rub bar. These clearance values are measured when the concave control lever 2 in position 7.

The concave should be blocked in this position.

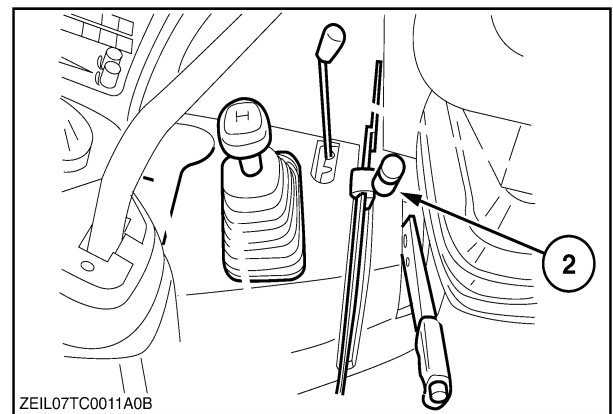

103

In case it is necessary to change the concave position, proceed as follows:

1. Loosen the lock nuts 1.
2. Remove the mounting blocks 2.
3. Adjust the concave as required with the nuts on the suspension rods.
4. Reinstall the mounting blocks 2 (*) and secure with the lock nuts 1.

NOTE: (*) Pay attention to the position of the mounting blocks 2 at the rear. The cut out of the rear mounting block should face towards the rear of the combine.

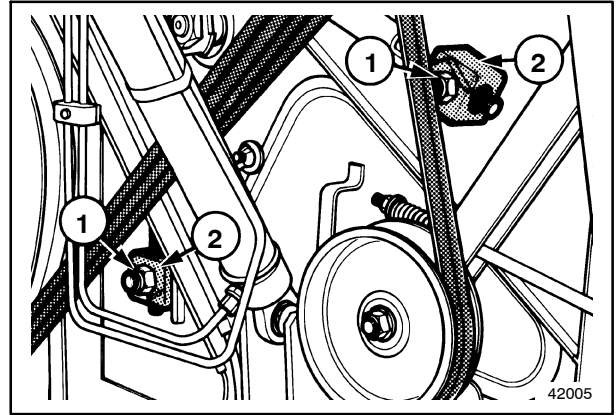

104

De-awning plates

The de-awning plates 1 increase the rubbing action of the drum and concave when threshing winter barley or difficult to thresh crops.

Depending on the needs, two or four de-awning plates (1) (delivered with the combine) can be installed.

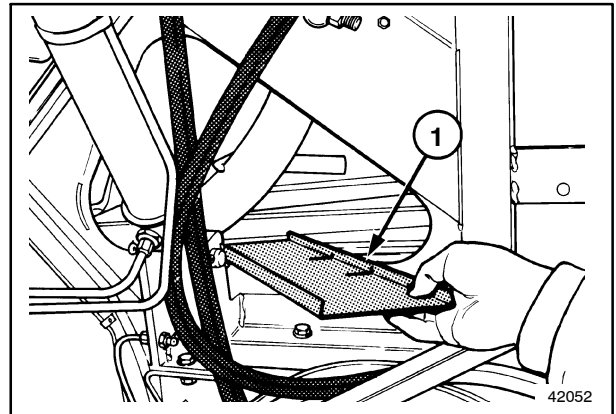

105

Proceed as follows:

1. Stop the engine and remove access covers as described in a previous paragraph.
2. Loosen the spring clamps 2.
3. Insert the de-awning plates 1 through the openings and hold them in position with the spring clamps 2 located in the hooks 3.

NOTE: Only install the rear de-awning plates if really necessary as partially closing of the concave inevitably means loss of capacity.

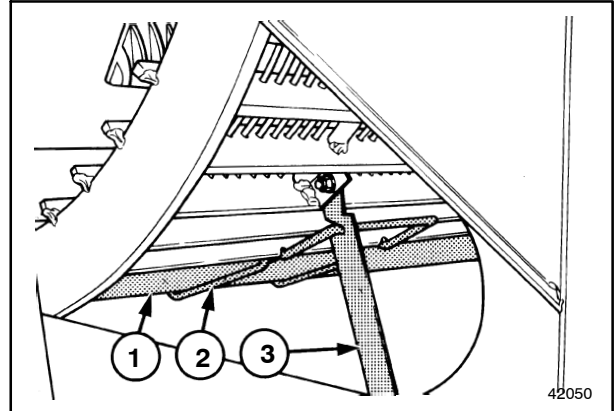

106

De-awning slats (accessory)

De-awning slats 1 can be installed in the front section of the concave to improve the threshing efficiency in difficult to thresh wheat.

Proceed as follows:

1. Position the de-awning slats 1 in the two front sections of the concave, on top of the concave wires.
2. Position on each fixation bolt a mounting plate 2 (underneath the concave) and tighten the lock nuts.

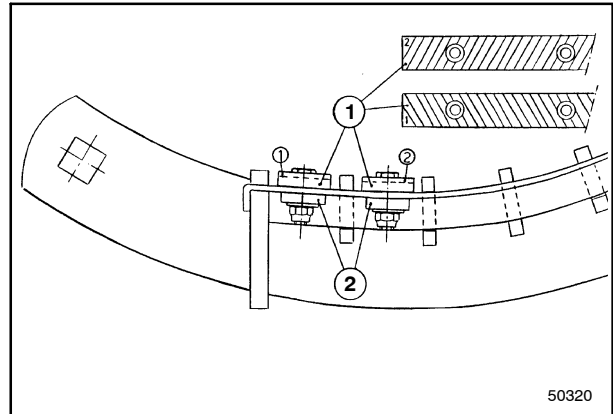

107

DRUM AND CONCAVE TYPE USE

- When harvesting cereals, it is advisable to use a standard drum and a cereal concave.
- When harvesting maize, it is advisable to use a standard drum and a maize concave.
- When harvesting rice, a rice drum with peg tooth bars and a rice concave should be installed.

If necessary, the concave and/or rice drum can be converted for harvesting other crop types (for example in case of changing from cereals to maize equipment).

This conversion must be carried out by your dealer.
Refer to Section 7 – ACCESSORIES.

BEATER

The beater, which runs at 875 rpm, is accessible through the two inspection holes 1 in the grain tank.



CAUTION

Before accessing to the grain tank, stop the engine and remove the ignition key.

The beater is equipped with four adjustable stripper plates 2 which are factory-set as close as possible to the drum rasp bars without touching them. The plates 2 are adjusted by the screws 3, if required. When carrying out this job, first search for the closest drum rasp bar.

The beater concave is not adjustable.

NOTE: In case of grain crackage (in maize), beater pins can be installed.

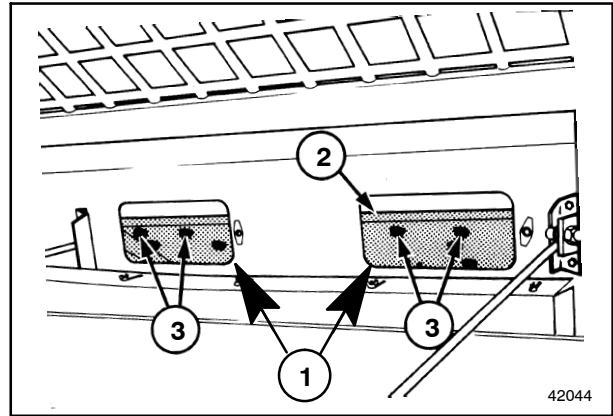

108

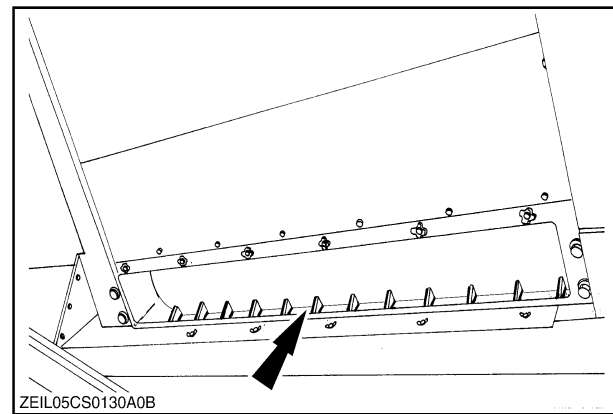

109

ROTARY SEPARATOR [if installed]

Rotary separator speed

The rotary separator can operate at two different speeds:

- 760 rpm: factory-set speed for most cereal crops such as wheat, barley, rye, oats, etc.
- 400 rpm: for harvesting maize, grass seed, beans, peas, soya, sunflower, rape seed, etc.

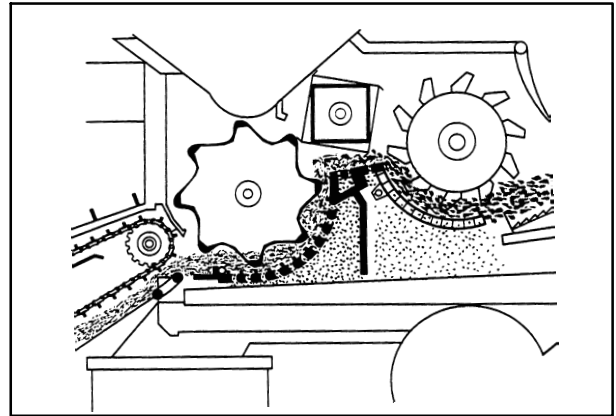

110

Speed adjustment

To change the speed, proceed as follows:

1. Move lever 1 out of the hook 2 and upwards. This will move the idler 3 downwards and loosen the belt tension.
2. Fit the belt in the other grooves of both pulleys.
3. Move the lever 1 downwards and secure the lever in the hook 2 as shown.
4. Check the belt tension and adjust, if necessary, (refer to SECTION 4 – LUBRICATION AND MAINTENANCE, paragraph headed "Belts and chains").

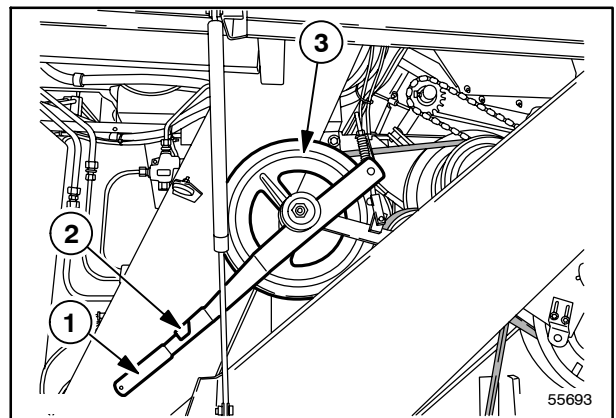

111

Rotary separator wear plates

To prevent damage of the rotary separator, it is recommended to install wear plates to harvest maize or rice.

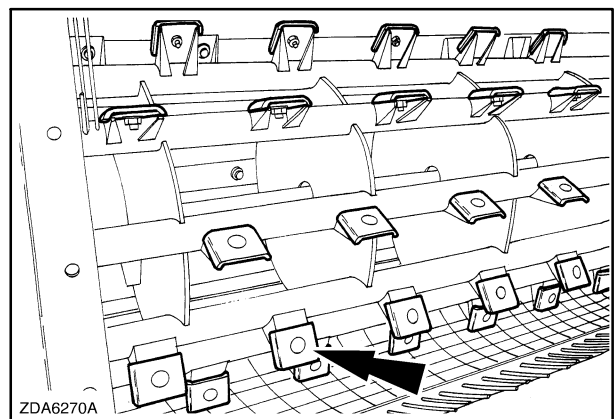

112

STRAW-RETAINING CURTAIN

• **If rotary separator**

Only one position

• **If no rotary separator**

The straw retarding curtain 1 (fig. 114) can be set in two positions:

- **Front position A:**
Used in crops with short straw and in maize.
Used for improved separation.
- **Rear position B (factory-set position):**
Used in normal and long-strawed crops.

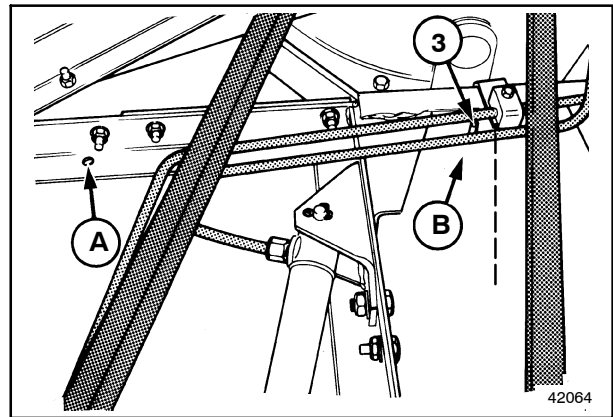

113

To change the position of the straw retarding curtain, proceed as follows:



CAUTION



Before entering the straw walker area, stop the engine, remove the ignition key and engage the parking brake.

1. Obtain access to the straw walker area.
2. Remove the two cotter pins 2 on the inside.
3. Slide the shaft 3 to one side. (fig. 113)
4. Insert the shaft 3 in the hole for the second position, slide it in the curtain bushing and secure with the cotter pins 2.

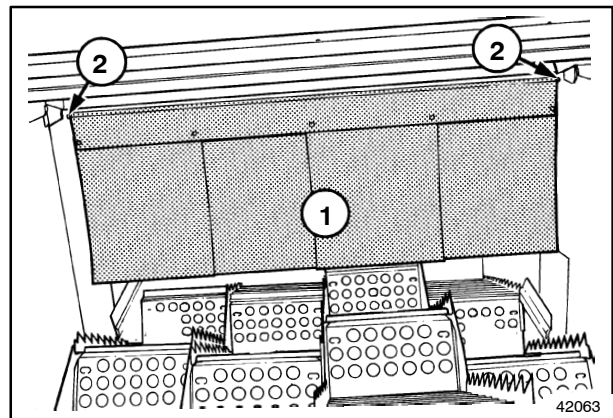

114

STRAW WALKERS

The straw risers 1 on the straw walkers assist in separating grain from the straw.

If required, they can be removed in crops which are likely to cause blockages, e.g. barley.

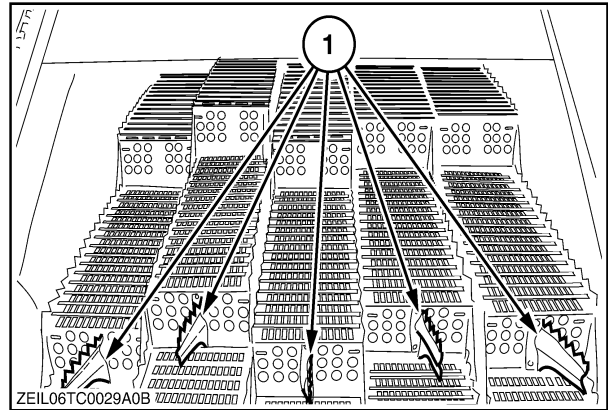

115

When operating in short, brittle straw crops, vertical cover plates 2 [accessory] can be installed to prevent short straw from reaching the sieves and overloading them.

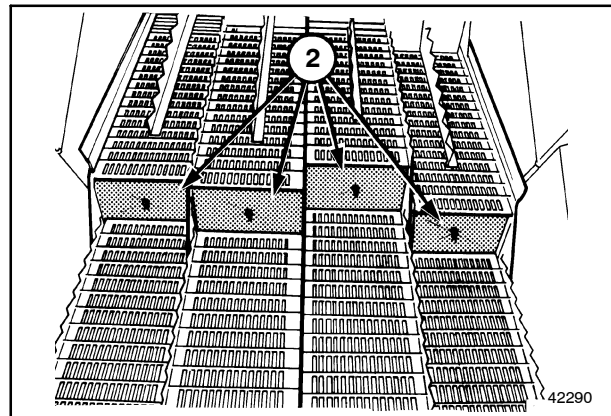

116

DELETED

SECTION 3 – FIELD AND SITE OPERATION

SIEVE TYPES (AVAILABLE)

Sieve	Type	Crop	Position**	Opening	Fig.
Upper sieve (*)	Hart Carter 1-1/8"	Cereals	Lower	adjustable	117
	Hart Carter 1-5/8"	Maize	Upper	adjustable	118
Lower sieve	NH 1- 1/8"	Cereals	-	adjustable	119
	Round-hole sieve				
	Dia. 3.5 mm	Small grain	-	fixed	120
	Dia. 16 mm	Maize	-	fixed	
Dia. 18 mm	Maize	-	fixed		

(*) Both fixed and self-levelling cleaning system.

(**) Sieve position on frame (see further).

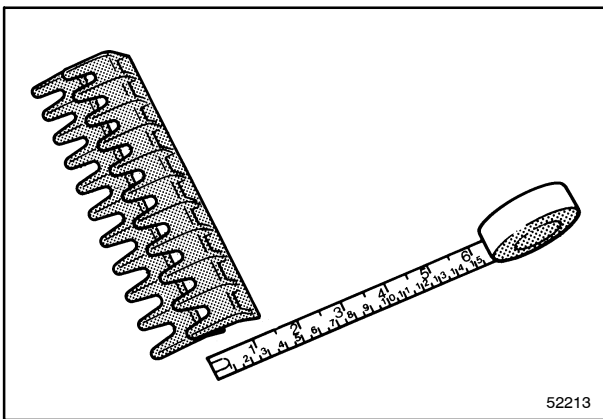

117

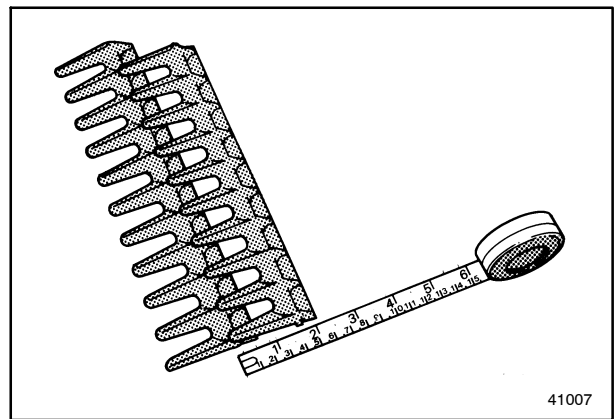

118

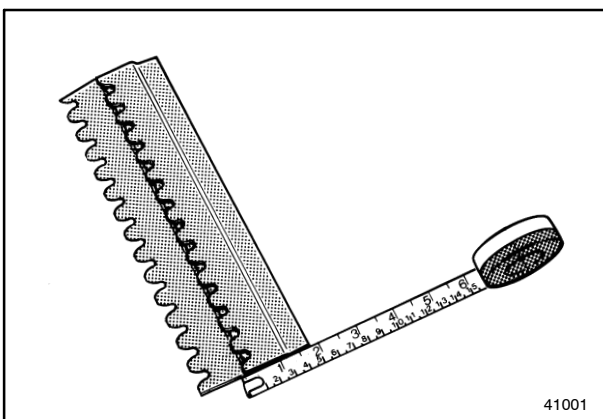

119

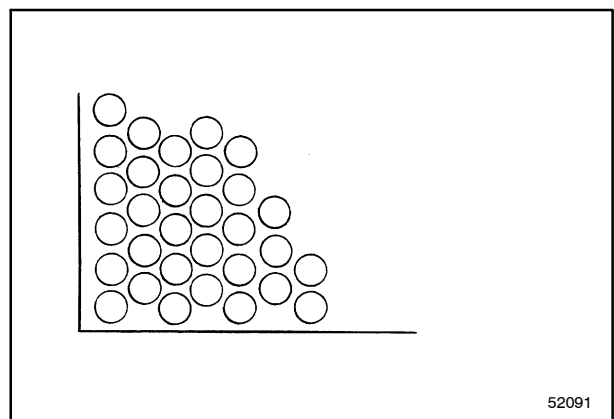

120

LOWER SIEVE

Sieve opening adjustment

Open the cover 5 to obtain access to the lever 4 to adjust the sieve openings. During the operation, the lower sieve should be opened as much as possible, however consistent with producing a clean grain sample. Use the settings as recommended in paragraph headed "Summary of the machine settings for different crops" at the end of this Section.

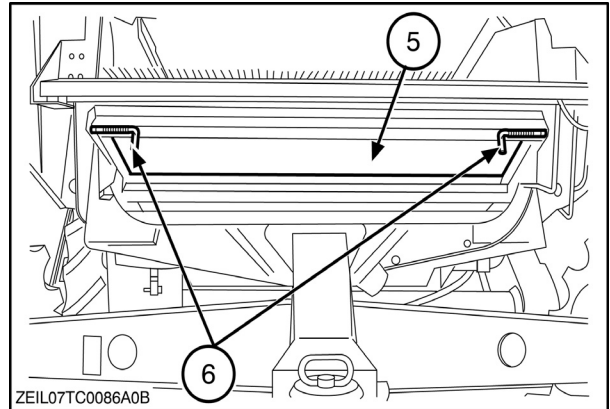

121

Positioning, removal, installation

To remove the sieve, open the cover 5 by the lever 6, (fig. 121), remove the bolt 7 (fig. 123) on both sides and slide out the lower sieve.

The lower sieve can only be installed in one position.

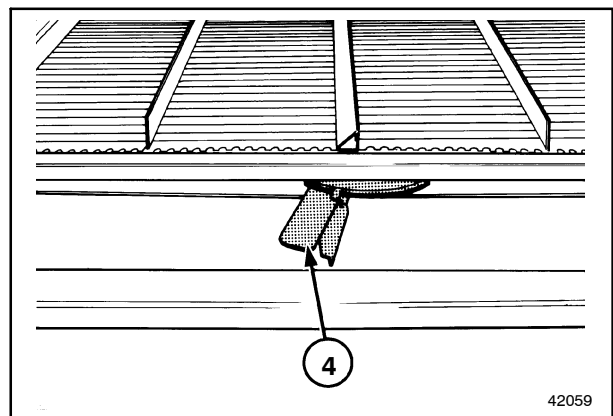

122

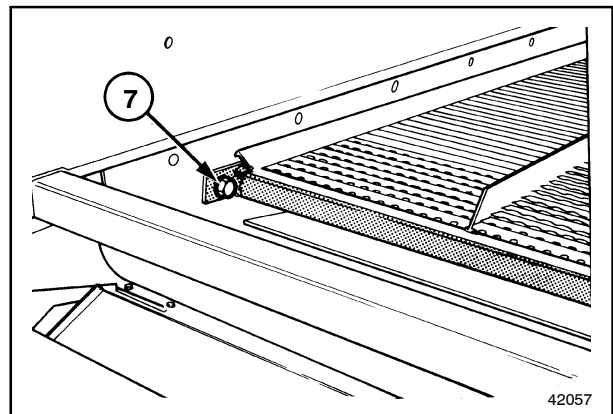

123

UPPER SIEVE

Sieve opening adjustment

Adjust the sieve openings by the lever(s) 1.

Operate with the upper sieve open as wide as possible, however without producing excessive thrash which will fall onto the lower sieve.

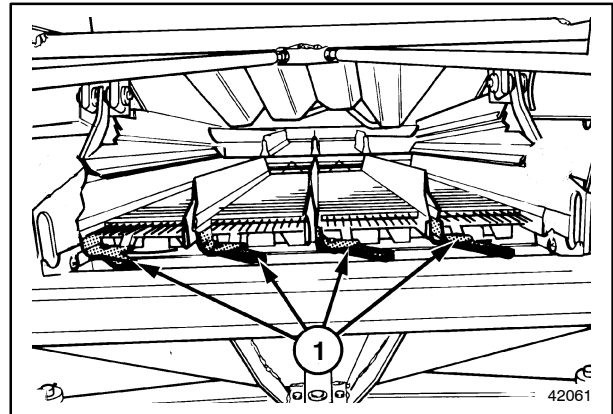

Self-levelling upper sieve

124

On machines with fixed cleaning system:

- The rear part of the upper sieve can be adjusted separately by the lever 3.

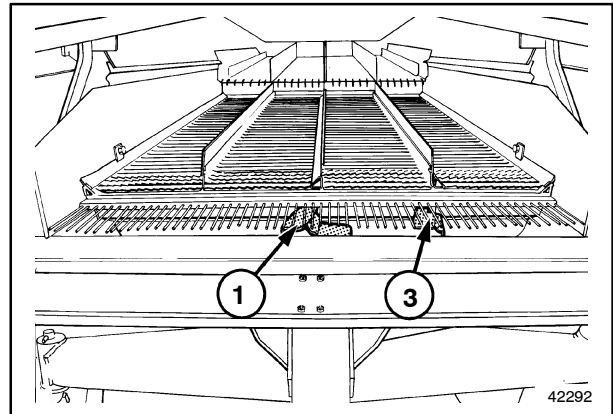

Fixed upper sieve

125

- When operating in hilly conditions, dividers 10 can be installed on the upper sieve. When constantly working in flat conditions, it is recommended not to use these dividers.

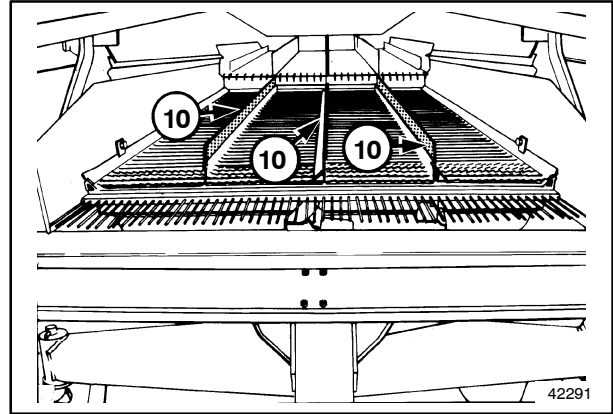

126

The upper sieve finger grate(s) can be replaced by graepel extension(s) [accessory] to prevent short straw and weeds from passing to the returns auger.

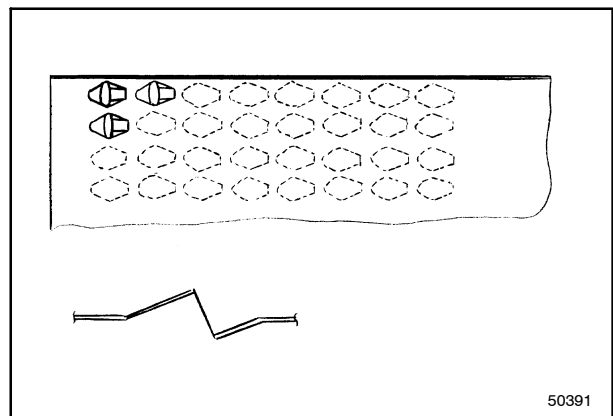

50391

127

Positioning, removal, installation

On machines equipped with a fixed cleaning system, the upper sieve can be fitted in three different positions.

On machines with a self-levelling cleaning system the upper sieve can be fitted in two different positions.

To remove the upper sieve or to change the sieve position, remove the bolts 6 on both sides. Reinstall the bolts 6, afterwards.

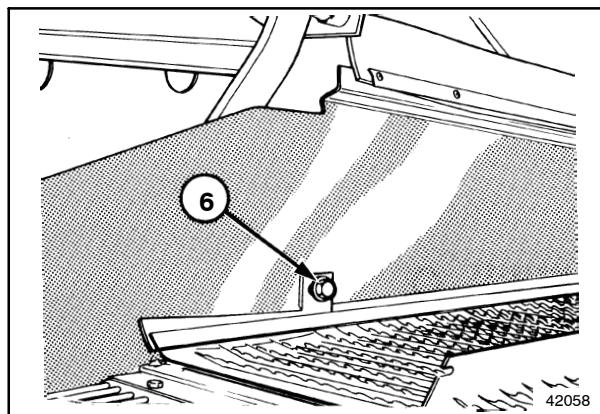

128

On machines equipped with self-levelling cleaning system:

1. Turn the ignition key in the contact position.
2. Engage the self-levelling cleaning system override switch 98 at the rear of the combine, until roller 8 latches into the notch of the upper sieve front profile.

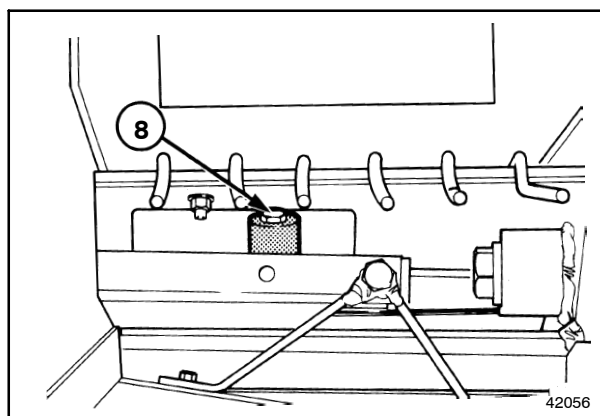

129

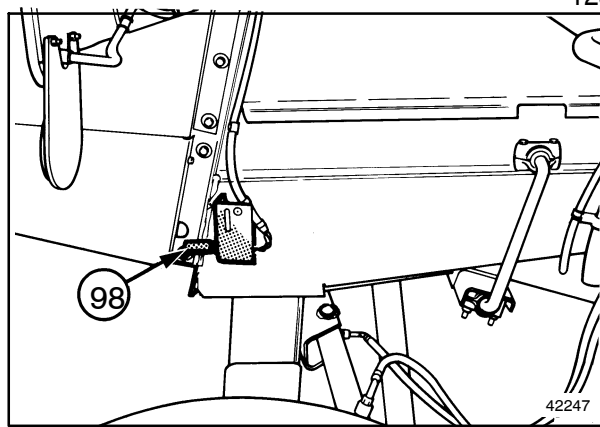

130

Sieve position	Self-levelling upper sieve	Fixed upper sieve
Low position	Cereals	Cereals
Mid position	Not applicable	Cereals on slopes
Upper position	Maize	Maize

Self-levelling cleaning system (if installed)

This system has self-levelling sections of the upper sieve and moving grain pan dividers in order to obtain an even grain distribution over the whole sieve surface when operating on side slopes.

Grain pan dividers

The **grain pan dividers can be set in a fixed position** when operating in very damp conditions or when harvesting maize at freezing temperatures (risk of material sticking on the grain pan). In this case only the upper sieve sections are levelling.

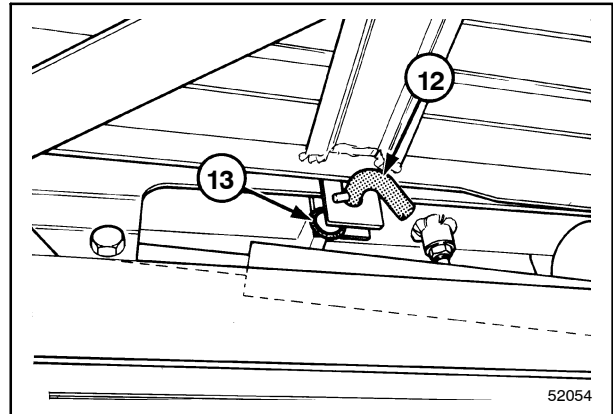

131

Proceed as follows:

1. Drive the machine on a perfectly level surface with the threshing mechanism engaged.
2. Disengage the threshing mechanism and stop the engine.
3. Leave the ignition key in the contact position.
4. Check if the holes at 11 are in line. If not, adjust with the levelling system override switch.
5. Remove hairpin cotter 13 and the pin 12.
6. Insert the pin 12 from the front, as shown.
7. Lock it with the hair pin cotter 13.

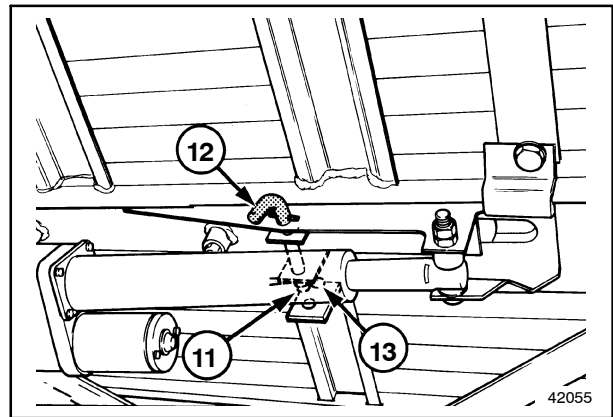

132

CLEANING FAN

FAN SPEED ADJUSTMENT

- **Manual adjustment (if applicable)**

The cleaning fan rpm can be adjusted with the control lever 1 on the right-hand side of the combine.

Level 1 position	Approximate fan speed (rpm)
1	320
2	350
3	380
4	420
5	450
6	510
7	550
8	600
9	660
10	730
11	790
12	810
13	850
14	920
15	950

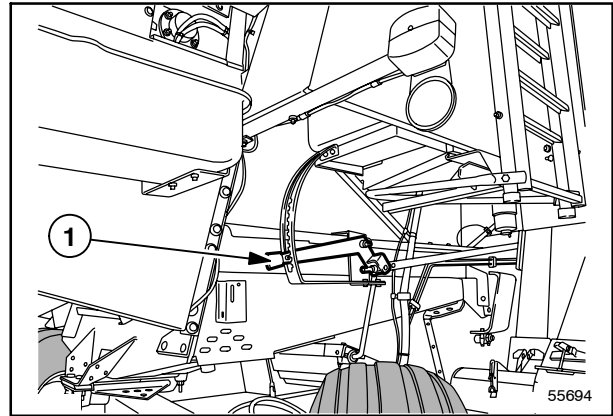

133

Change the fan speed only when the threshing mechanism is engaged.



CAUTION



Be careful when changing the fan speed, as the threshing mechanism is engaged.

The fan speed cannot be checked on the tachometer.

- **Electrical adjustment (if applicable)**

The cleaning fan speed can be adjusted electrically with the fan speed rocker switch from the right-hand console and can be read from the monitor.

It is only possible to change the fan speed when the threshing mechanism is engaged.

—  **WARNING**  —

Do not change the fan speed if the engine and threshing mechanism is not running to avoid deformation of the adjustment mechanism.

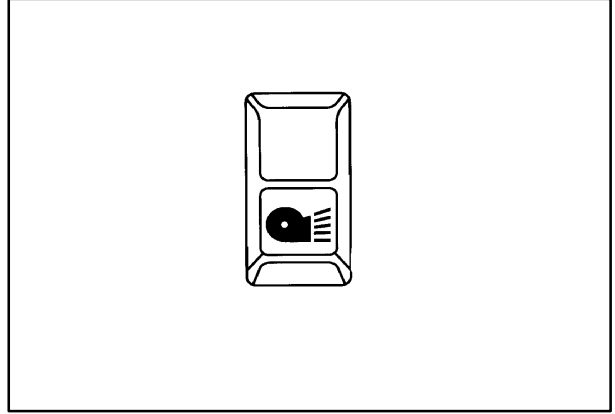

134

Adjust it to suit the nature of the crop, chaff load and moisture content. A low fan speed kit can be installed to obtain a lower fan speed regulation when threshing small seeds. An insufficient air blast will reduce the "clean area" of the top sieve causing a dirty sample or grain loss (grain will shake over the end of the shaker shoe).

The best way to check whether the volume of air is satisfactory is to complete a "kill-stall", i.e. stopping the engine with the threshing mechanism engaged and checking the sieve coverage pattern. Refer to paragraph headed "Kill-stall" in this section.

If this method of checking is used:

- The rakes must be clean while the sieves must be evenly loaded. Little or no grain should be found on the rear part of the upper sieve.
- If the whole sieve is clear of grain and chaff, the volume of air is too high. The grain will be blown out of the machine and clean grain will be transported over the lower sieve into the returns cross auger.
- If the upper sieve is full of grain, the volume of air is too low, so that the wind does not blow through the chaff. Therefore grain will be shaken off the sieve together with the chaff.

Sieve operation can also be checked by collecting material coming from the rear of the cleaning shoe and checking the sample for grain loss.

RETURNS SYSTEM

Cleaning access



CAUTION

Always stop the combine completely, remove the ignition key and engage the parking brake before cleaning one of the following parts.

To clean the returns bottom auger, remove the cover 1 and open the guard 2.

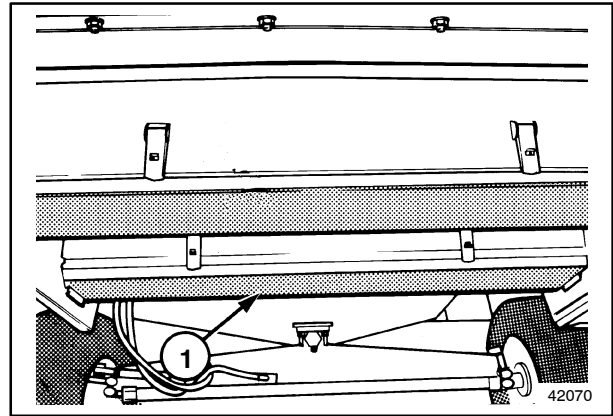

135

To clean the returns elevator, remove the guards 3 and 4.

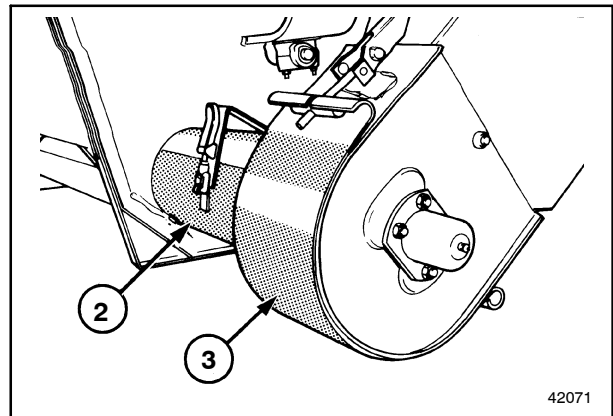

136

On the elevator chain two metal scrapers 5 are fitted to two of the paddles to keep the elevator clean when harvesting in damp conditions.

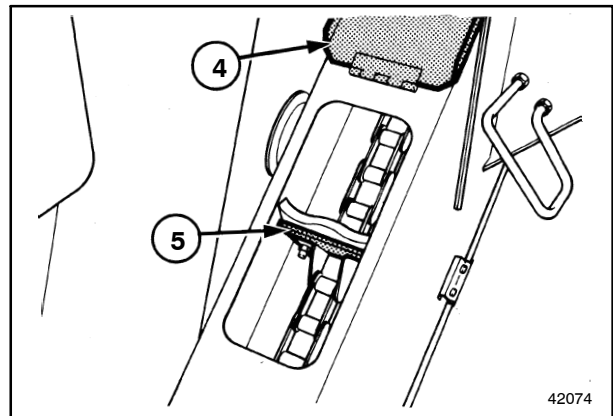

137

To clean the returns cross auger to the drum, open the cover 6.

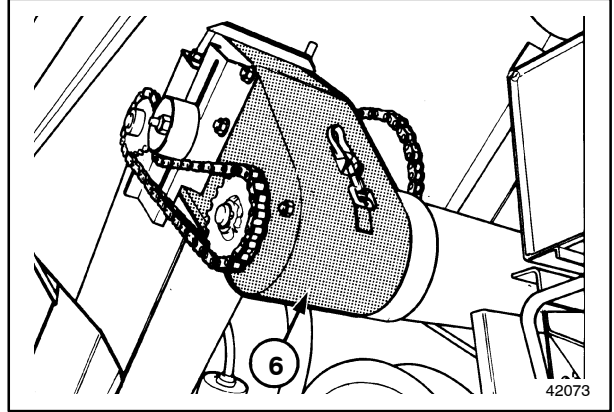

138

Returns

IMPORTANT: For maximum efficiency, keep the amount of material in the returns elevator to the absolute minimum.

Excessive returns will:

- High risk of grain damaging.
- Sieve overload with consequent grain loss.

The amount of returns can be checked through cover 4 after performing a kill stall.

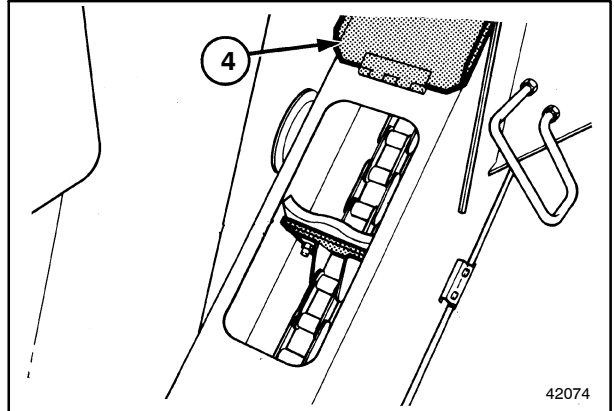

139

How to limit the returns:

1. When too much clean grain is found in the returns elevator:
 - Open the lower sieve as much as possible, consistent with producing a clean grain sample.
 - Avoid excessive fan rpm, to prevent clean grain from being blown over the lower sieve into the returns cross auger.
2. When an excess of short straw and thrash is found in the returns elevator:
 - Keep the fan rpm high enough to blow the chaff out of the machine.
 - Do not open the top sieve too wide to prevent excessive chaff from getting onto the bottom sieve.

GRAIN STORAGE/UNLOADING



CAUTION



Drive always on public roads with an empty grain tank.

Grain tank filling system



CAUTION



Always stop the combine completely, remove the ignition key and engage the parking brake before cleaning one of the following parts.

- To clean the grain cross auger, remove the cover (7).

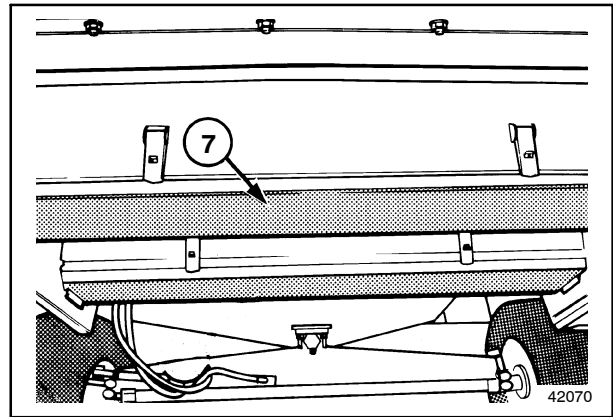

140

- To clean the grain elevator, open the cover (8).

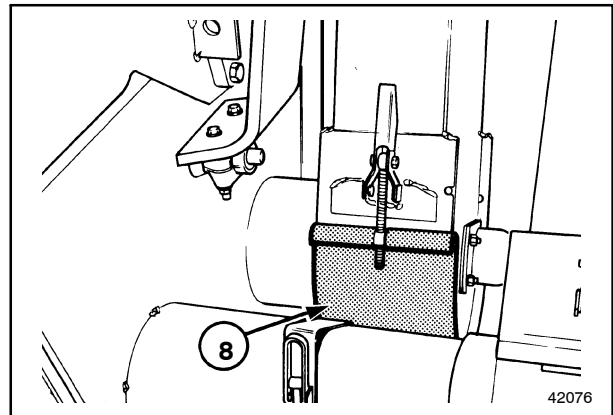

141

On the grain elevator chain two, metal scrapers (10) are fitted to two of the paddles to keep the elevator clean when harvesting in damp crop conditions.

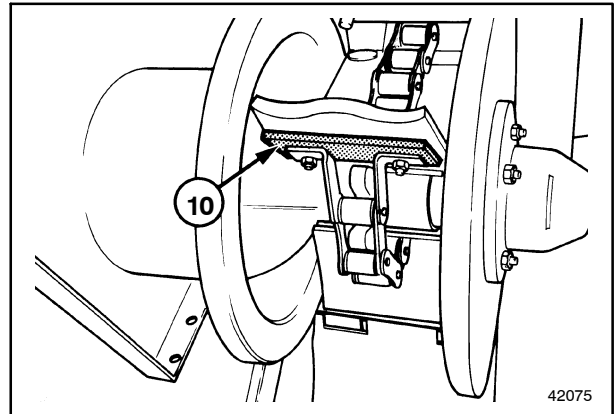

142

Grain tank cover

During operation, the cover (14) can be left in the closed (see figure) or open (folded) position.



CAUTION



During the operation on field with open cover 14, the safety guard 16 must be remain in the closed position.

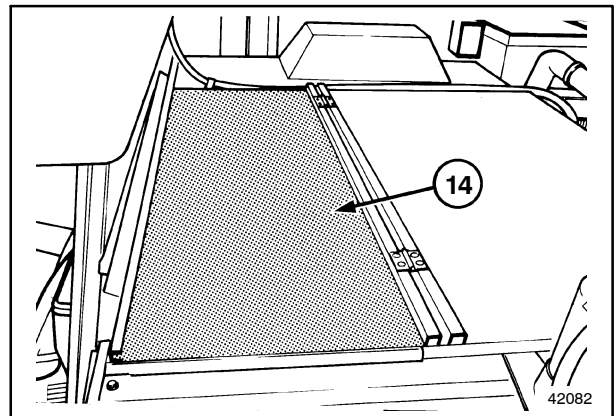

143

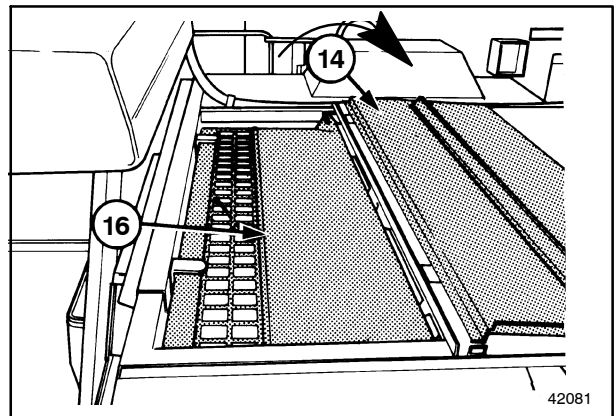

144

Grain sample

A grain sample can be taken through inspection door 11 when starting off in the field.

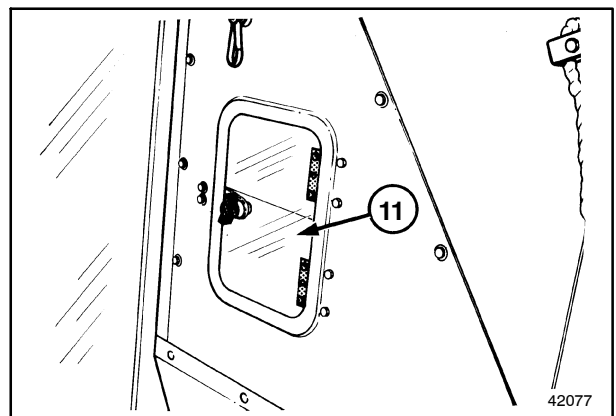

145

Grain tank unloading auger



CAUTION



Before entering the grain tank, stop the combine completely, remove the ignition key and engage the parking brake.

A cover plate is fitted over the grain tank unloading auger. This cover plate is fitted with the plate 12, which can be adjusted to regulate the unloading rate according to the nature and moisture content of the grain being handled.

To increase the unloading rate, raise the plates; to reduce, lower the plate.

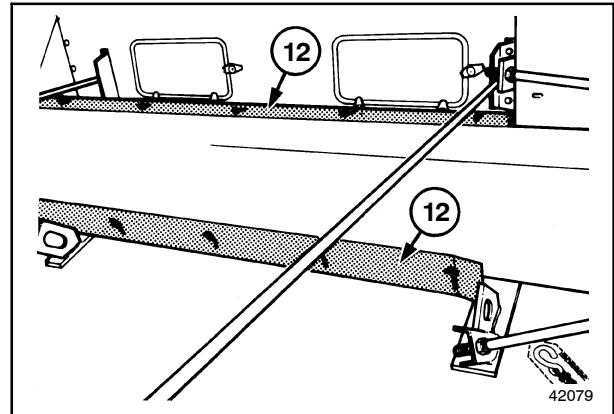

146

Unloading tube

The unloading tube is controlled hydraulically from the operator's platform. A warning light is provided in the cab to alert the operator when the unloading tube is not in the fully closed position as this can be an operating hazard in fields with trees, high tension wire pylons, telegraphic poles, etc.



CAUTION



While driving on public roads the unloading tube must be kept in closed position.

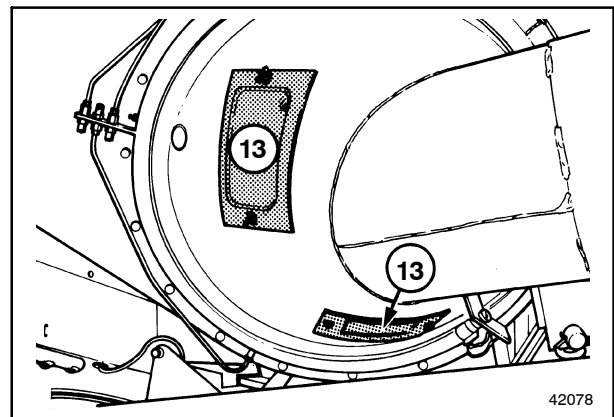

147

The unloading tube is fitted with two covers 13 to provide access for cleaning and lubricating the auger.

IMPORTANT:

- Keep the unloading tube closed as much as possible during field operation.
- When engaging the unloading mechanism, ensure the unloading tube is open more than 45°.

Grain tank level sensor (if installed)

Position the sensor (1) vertically located inside the grain tank according to the crop type to be harvested.

When the grain inside the grain tank reaches the level sensor (or when the sensor is gently pushed), the following occurs:

- The grain tank level warning light on the control module will illuminate.
- The buzzer sounds for 5 seconds.
- The revolving flash lights will be switched on:
 - For 7 seconds with the revolving flash light tumbler switch in position “1”.
 - As long as the lower level sensor is activated with the revolving flash light tumbler switch in position “2”. (middle position)
 - In position “3”, the revolving flash light will remain on for road transport.

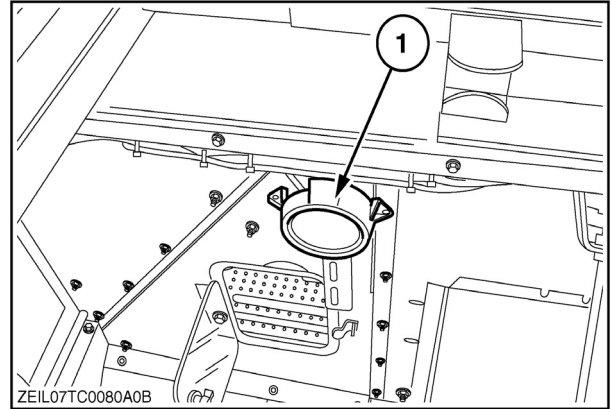

148

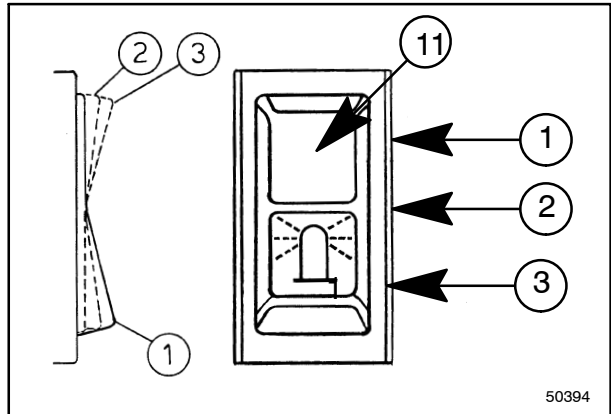

149

STRAW HANDLING

Straw chopper (if installed)



Always stop the engine and wait until the chopper rotor has come to a complete standstill before working on the straw chopper.

Transport position

For road transport, the chopper chute (1) must remain in the operating position, as shown, except when a header trailer is attached. In this case, the chute (1) should be swung up completely.

To move the chute (1) up, disengage the latches (2) on both sides, swing the chute (1) completely up until the lock latch (3) is engaged.

Swath-forming position

Move the straw guiding plate on the inside of the straw hood, to the rear with the lever 1.

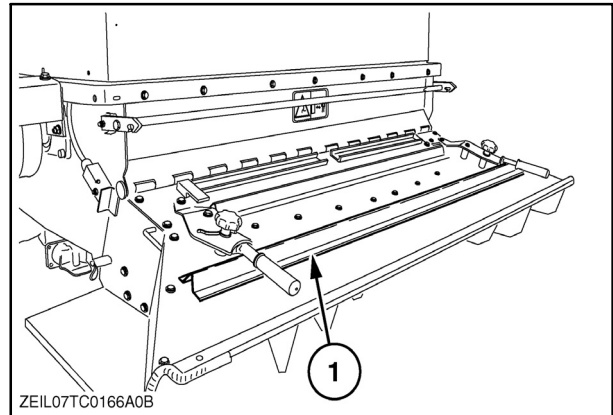

150

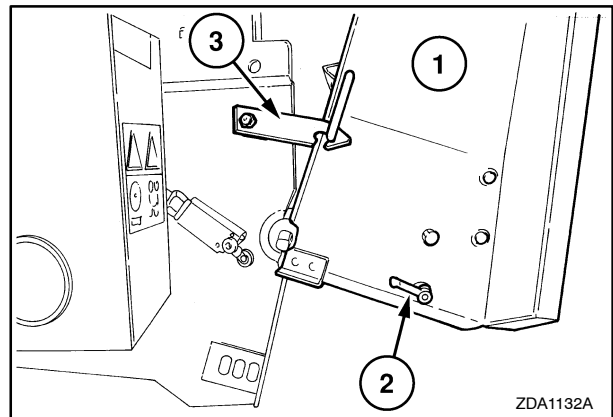

151

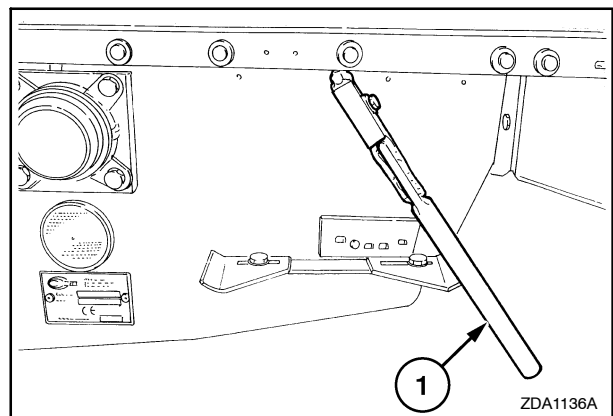

152

Swathing rake

Two swathing rakes (1) can be installed on both sides in the straw hood to reduce the swath width for a following baler.

■ If not used, this can be stored as shown.

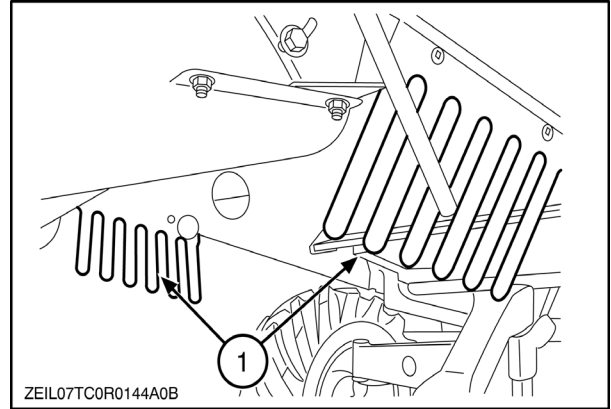

153

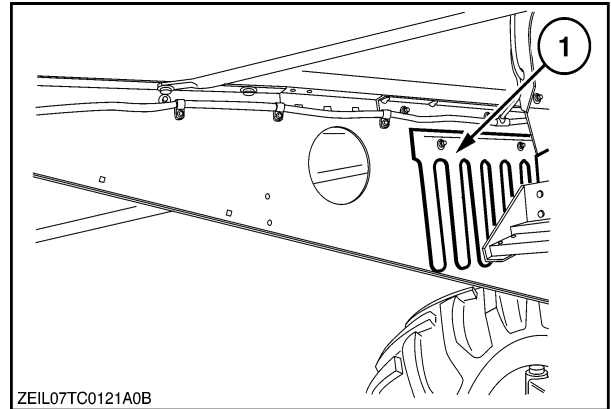

154

Chopping position

1. To change the operating position, disengage latch 3, swing chute 1 down and secure it with latches 2 on both sides.



CAUTION



Never swing the chute up during or just after operations as the chopper continues to rotate for considerable time.

NOTE: With the chopper chute in swing-up position, the chopper will not run, even if engaged.

Latch 4 has three positions (1, 2 and 3), to secure the spreader depending on the spread patterns required:

Position 1: narrow spreading pattern

Position 3: wide spreading pattern

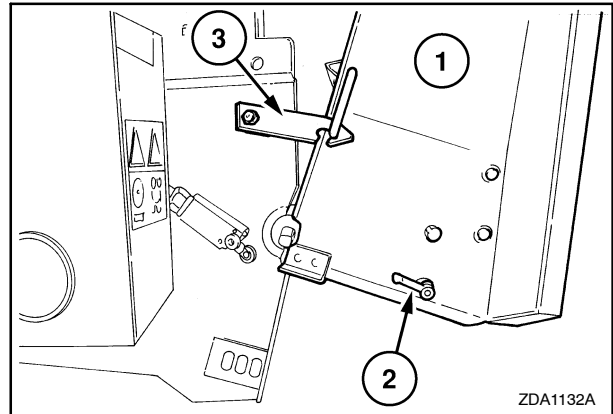

155

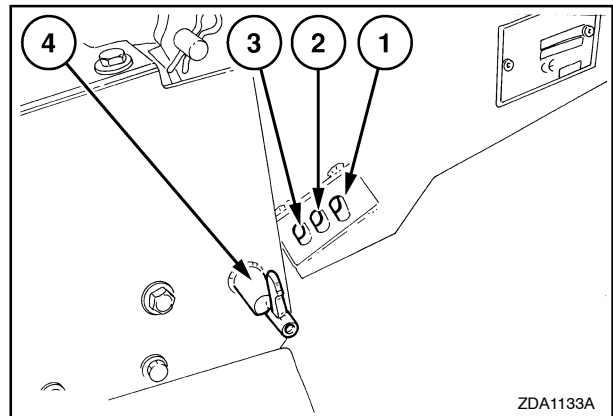

156

2. Move the straw guiding plate on the inside of the straw hood to the front (i.e. the chopping position).

NOTE: The lever is parallel to the straw guiding plate.

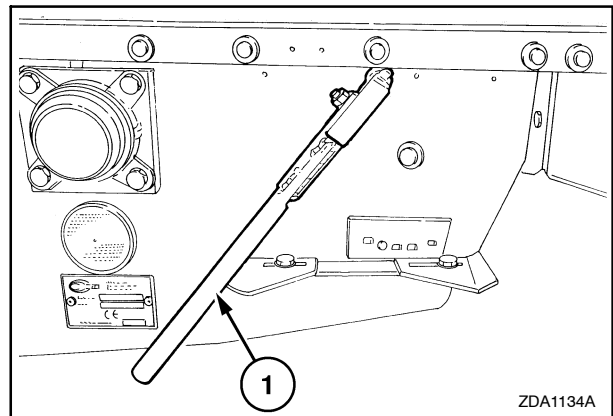

157

3. If needed, adjust the straw chopper chute deflector plates 2 in the spreader chute 1 to spread the material according to the header width. This must be carried out by trial and error in the field.

+ : wider spreading pattern

- : narrow spreading pattern

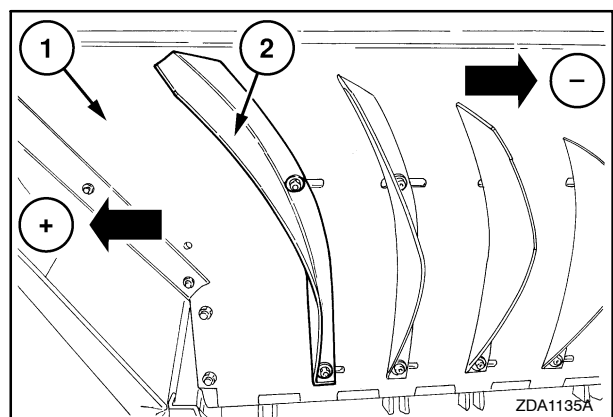

158

Manual adjustable deflector plates (if installed)

To adjust, proceed as follows:
On both sides:

1. Loosen the knob (1).
2. Move the handle (2).
moving the handle to the outside = wider spread pattern
Moving the handle to the inside = narrow spread pattern
3. After adjusting fix with the knob (1).

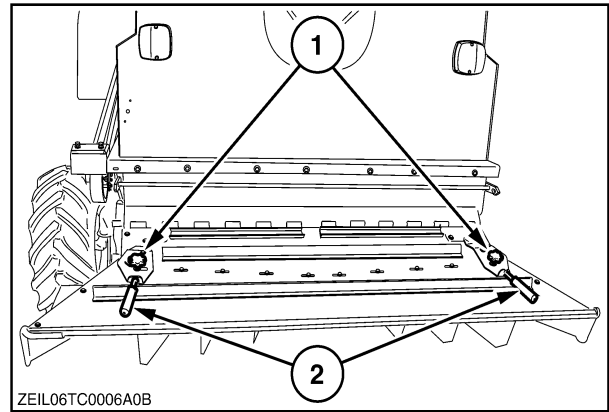

159

Remote adjustable deflector plates (if installed)

With the chopper spreader rocker switches in the cab it is possible to move electrically the spreader plates of the spreader chute from left to the right and from right to the left, depending on the wind direction and side slope.

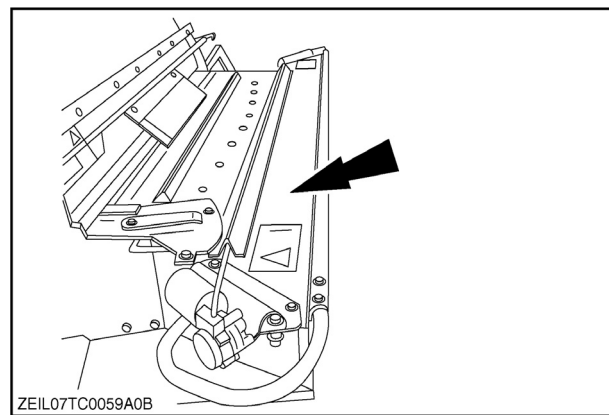

160

Straw chopper operation



CAUTION



Keep yourself and other people away from the rear of the combine when the straw chopper is engaged and operating.

Never run the straw chopper with imbalance, as this may cause serious damage to the straw chopper and the combine.

Do not use the straw chopper near the end of the field if there is a risk that crop or stones can be projected onto a public road.

With the engine running **at idle speed** and the threshing mechanism running, engage the chopper drive with the switch (23).

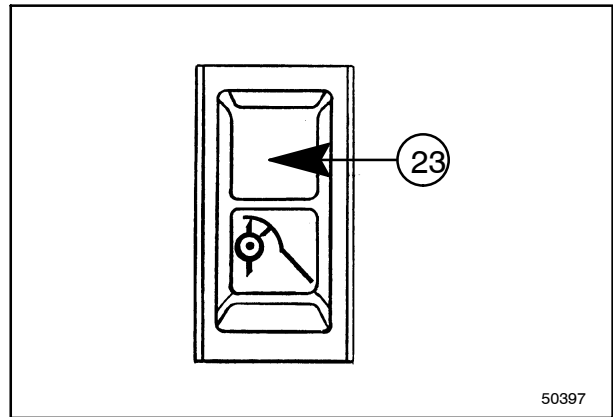

161



CAUTION



Before operating on the straw chopper, first of all, stop the engine.

NOTE:

- With the engine and the threshing mechanism running, the straw guiding plate in the chopping position and the straw chopper not yet engaged, the horn should be sound.
- The chopper clutch is automatically disengaged when the threshing mechanism is disengaged or when the chopper chute is not in chopping position.

Straw chopper clutch

In case the straw chopper clutch is broken, repair or replace it immediately. **It is absolutely forbidden to lock the clutch in engagement position**, since the knives of the straw chopper continue rotating with operating engine (even with the threshing mechanism disengaged).

Access to the straw chopper rotor

In case a blockage occurs, access to the chopper can be gained as follows:

1. Loosen the screw 1 and turn away the bracket 2 on both sides.
2. Pivot the straw guiding plate completely to the front to remove the blockage.

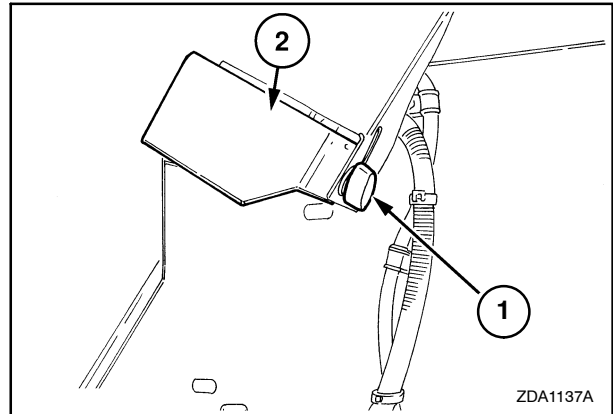

162

If repairs should be needed, remove the straw guiding plate 1 as follows:

1. Remove the Allen screws 2 on both sides.
2. Pull out pivoting shafts from both sides.
3. Remove the straw guiding plate 1.

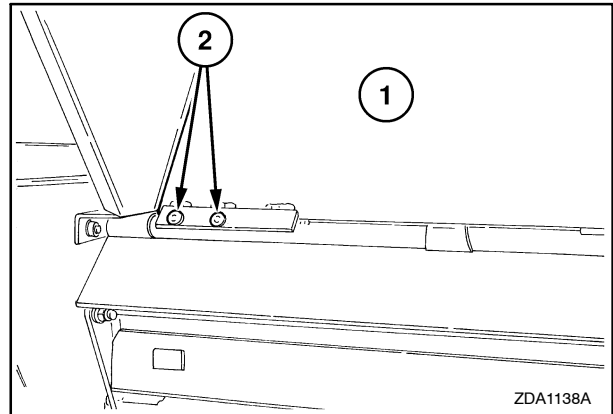

163

Straw chopper rotor knives

CAUTION

Do not work with damaged or broken knives. This is unsafe and the imbalance may cause severe secondary damage to the chopper and the combine.

The knives 1 on the chopper rotor have two cutting edges for double length of life. Oil the rotor knives regularly.

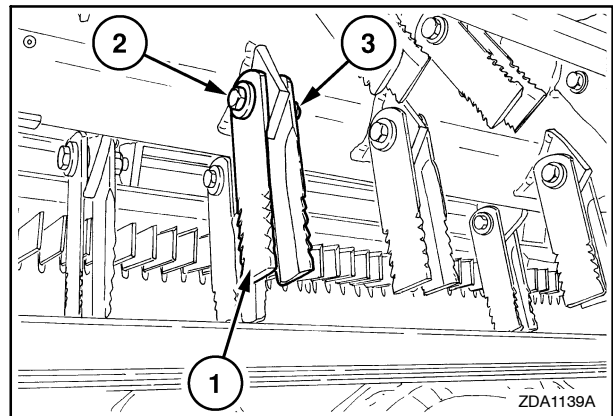

164

If required, the knives can be reversed or replaced. Proceed as follows:

1. Remove the bolt 2, taking care not to lose the two spacers and washers.
2. Reverse the knives or install new knives.
3. Insert the bolt 2 from the left-hand side. (facing direction of travel)
4. Tighten the nut 3.

NOTE: Always change the opposite knife to achieve a good balance.

Counter knives

It is possible to set the counter knives in 4 positions.

Crop type and/or harvesting conditions	Counter knives position
Dry straw	Position 1
Damp crop:	Towards the rear:
• Heavy straw	• Position 2
• Oil seed rape, peas and beans	• Position 3
Maize and sunflower	Position 4

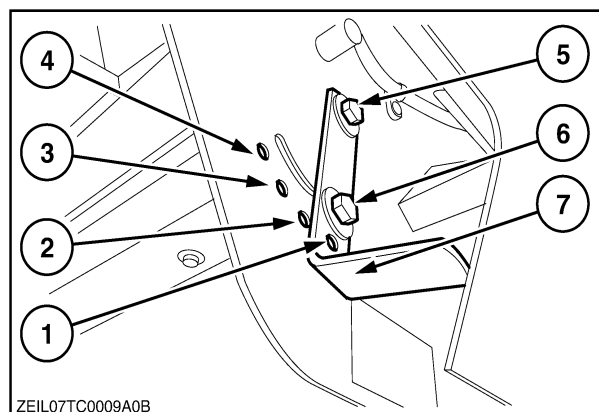

165

To reposition the counter knives, proceed as follows:

1. On both sides, loosen the bolts (5) and (6).
2. At the right-hand side, move the lever (7) to the desired position.
3. On both sides, tighten the bolts (6) and (5).

To replace the counter knives, proceed as follows:

1. Loosen the three bolts (1) (two turns) and remove the plate (2).

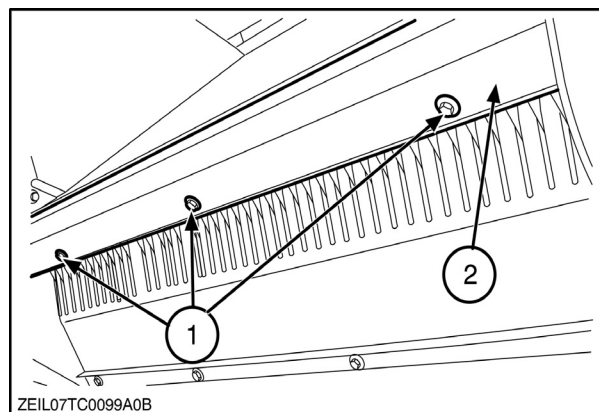

166

2. After replacing the counter knives (3), reinstall the plate (2) and tighten the bolts (1).

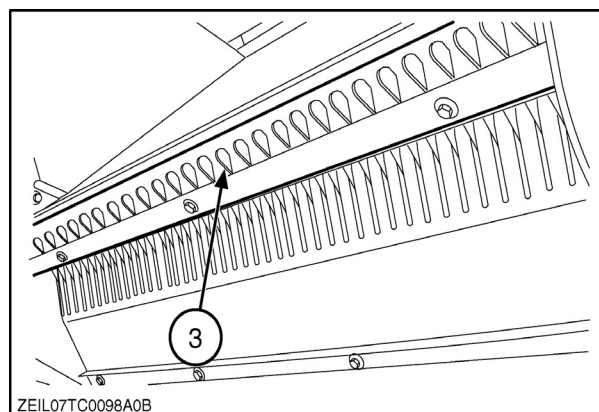

167

Chopping maize

For chopping maize, proceed as follows:

1. The rotor speed must be reduced by installing a larger pulley onto the hub of the rotor shaft. This pulley is part of the straw chopper slow down kit which is available as an accessory.
2. Install the straw chopper maize punching plate (2) (accessory), to protect the straw hood from possible damage.

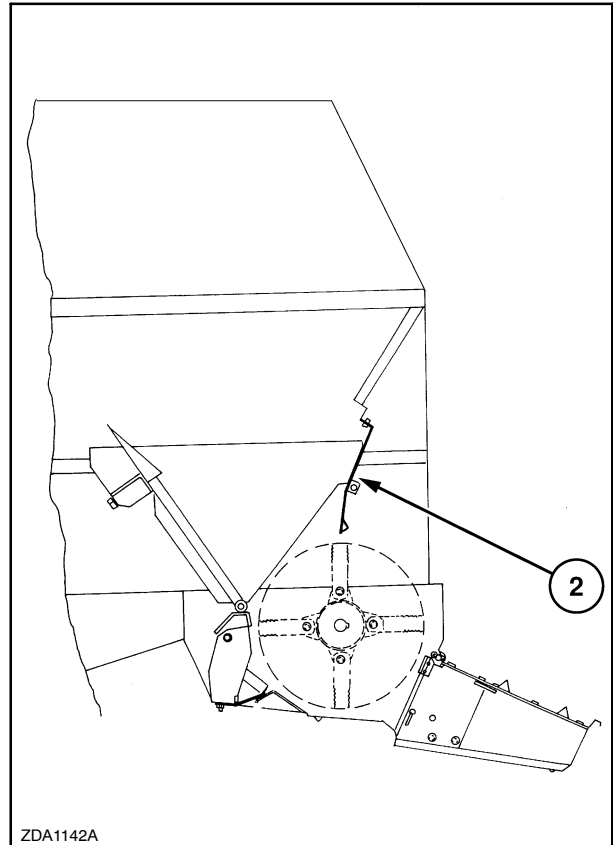

ZDA1142A

168

3. Set the counter knives in position (4).

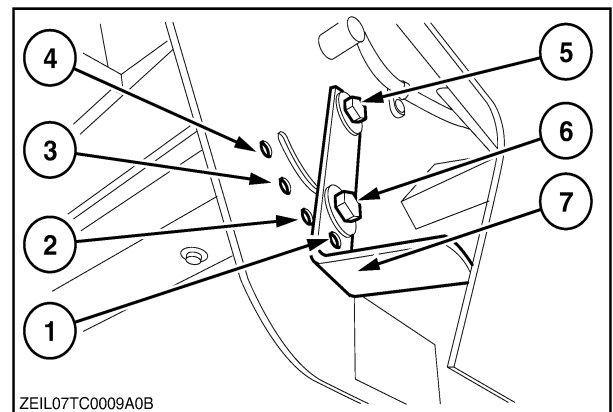

ZEIL07TC0009A0B

169

4. Reduce the rotor knives (2) by half and retighten the nut (1).

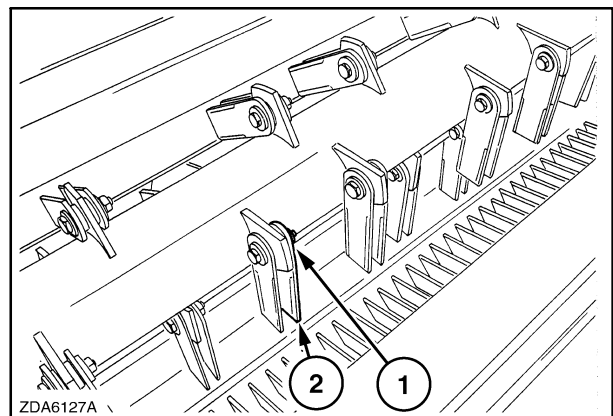

ZDA6127A

170

SECTION 3 – FIELD AND SITE OPERATION

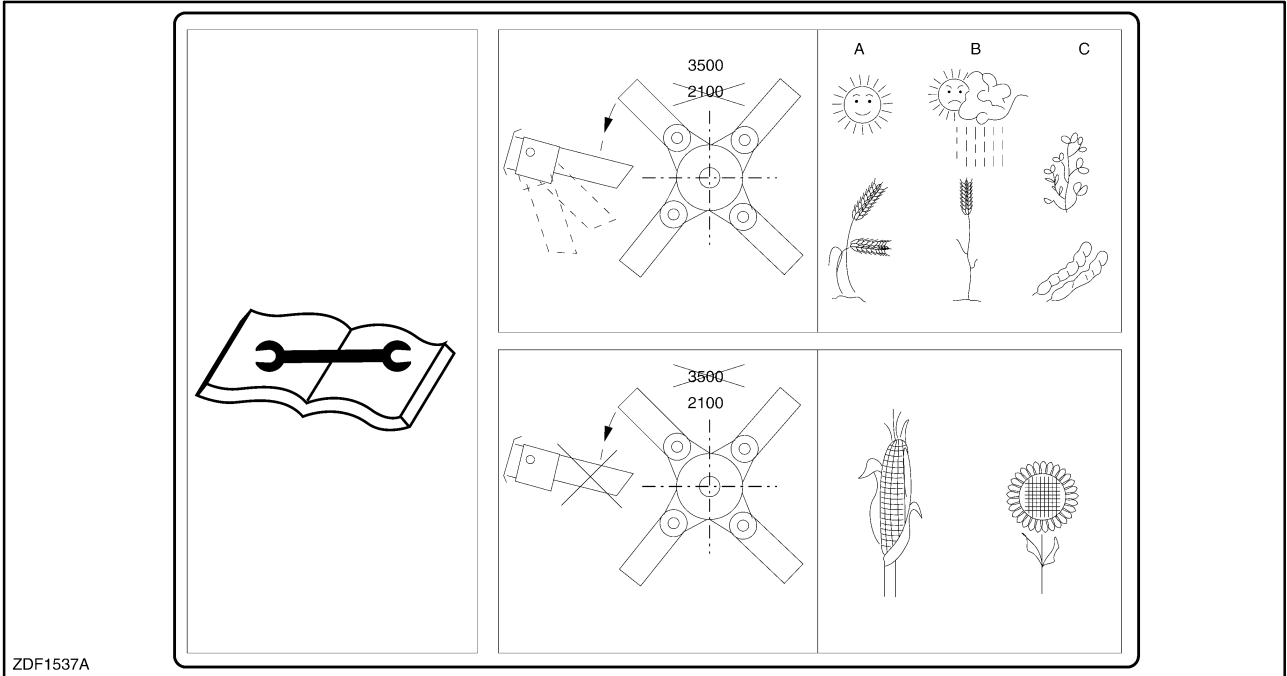

ZDF1537A

DELETED

Chaff spreader (if installed)

This chaff spreader is designed to spread chaff from the sieves directly to the sides down the ground. The chaff spreader is not allowed to use in maize. The chaff is blown and thrown from the sieves to the chaff spreader rotating discs. The rotating discs are provided with deflectors and fan blades which blows and throw the chaff over the whole width of the header.



Keep well clear off the chaff spreader at all times.



Never operating with an unbalanced chaff spreader. Imbalance can cause damage on chaff spreader and combine.



Always stop the chaff spreader by disengage the threshing mechanism and stop the engine.

Wait until all the rotating parts come to a complete standstill before working on the chaff spreader.

SECTION 3 – FIELD AND SITE OPERATION

■ The chaff spreader has **four** positions:

- Forward position: For spreading and to project the chaff into the straw.

Press the knob (1) and grip the handle (2) and move chaff spreader forwards.

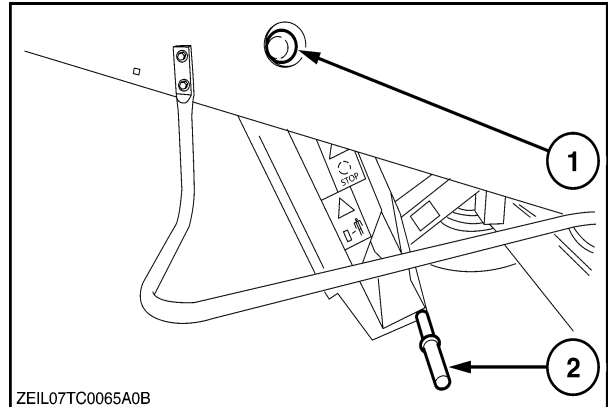

172

There is a possibility to adjust distance between sieves and chaff spreader.

Adjust if necessary with setting device (1).

- Position (d) gives longer distance between sieves and chaff spreader.
- Positions (a) and (b) give closer distance between sieves.
- The normal position is (c).

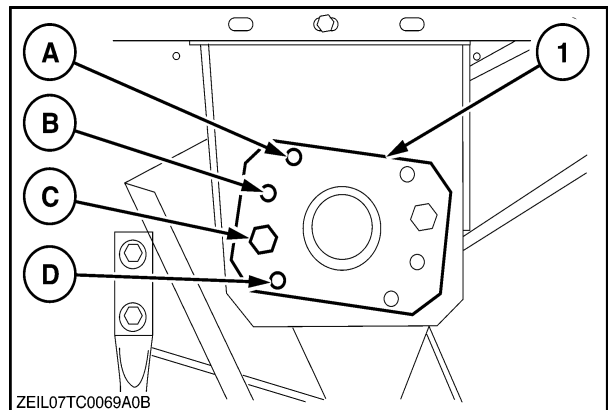

173

- Vertical position: Control of grain losses

Press the knob (1) and grip the handle (2) and press chaff spreader to vertical position.

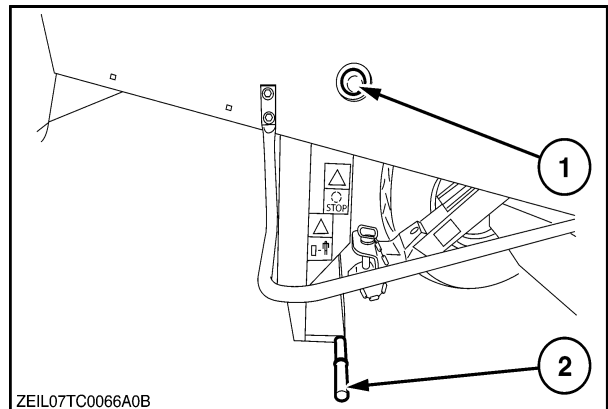

174

SECTION 3 – FIELD AND SITE OPERATION

- Setting of sieve position

Press the knob (1), grip the handle (2) and move chaff spreader to back position.



This position is not allowed to use when swathing straw.

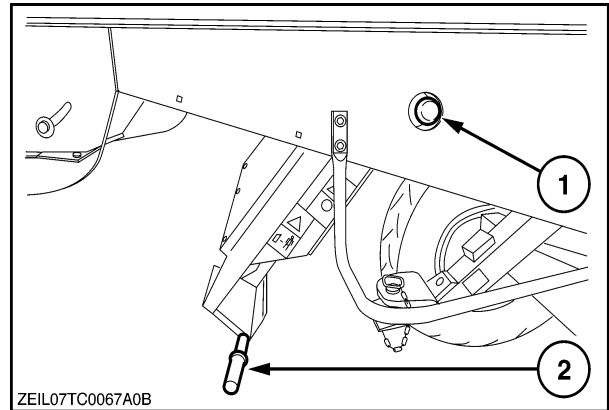

175

- Service position: to service or remove the sieves

Press the knob (1), grip the handle (2) and move chaff spreader as far as possible.



Always stop the chaff spreader by disengage the threshing mechanism and stop the engine.

Wait until all the rotating parts come to a complete standstill before working on the chaff spreader.

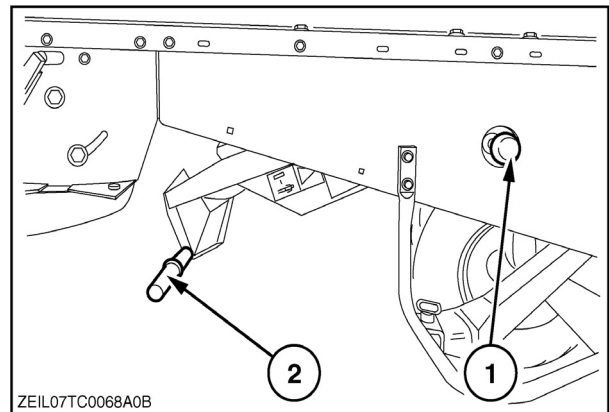

176

IMPORTANT: During field operation, the chaff spreader must **never be located in the service position**, even when it is not being used, as chaff accumulation under the straw walkers may occur!

Disengaging and removing the chaff spreader



To protect the spreader blades during harvesting maize, remove the spreader completely.

1. To have a better access for removing the spreader, lift the straw chopper chute (1) and secure it at both sides with the locks (3) (see fig. 178). Handle (2) is a position lock.

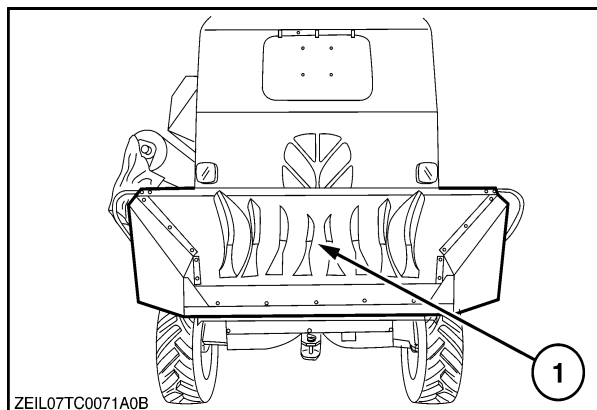

177

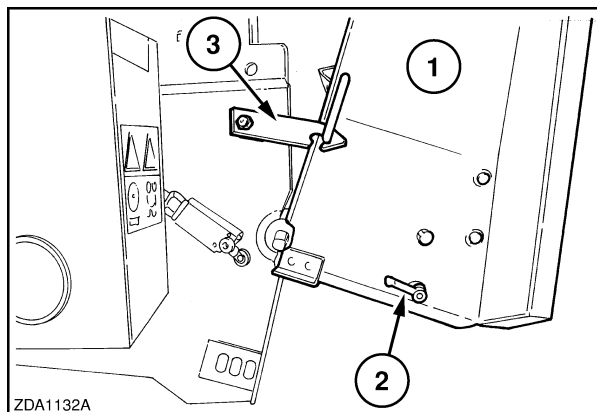

178

2. Place the spreader in vertical position (control of grain loss position or maize harvesting position) by pressing the knob (1) and grip the handle (2).

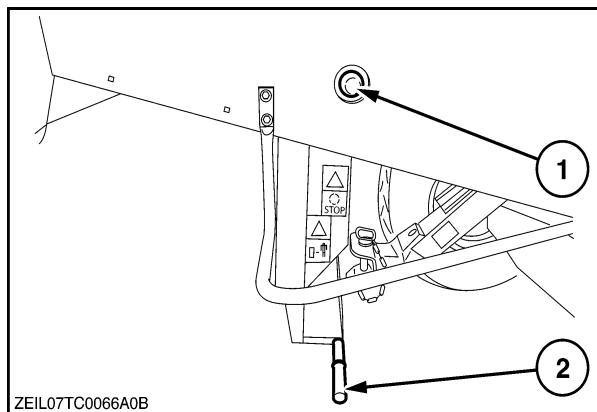

179

SECTION 3 – FIELD AND SITE OPERATION

3. Remove the protection cover (1) by loosening the two bolts (2) on the right side and the three bolts (3) with nuts inside the cover on the left side and lift the cover.
Now you discover the V-belt and pulley mechanism. (see fig. 181).

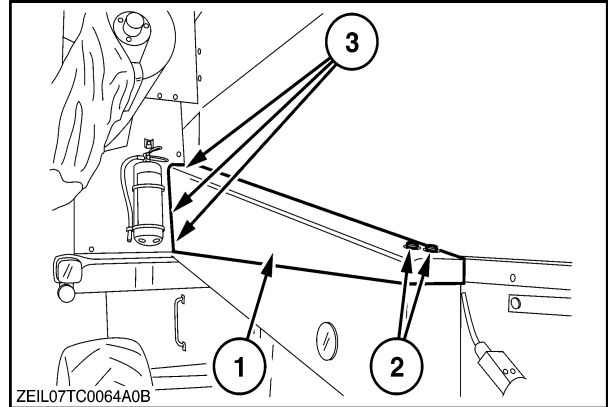

180

4. Loosen the nut (4) to release the spring (9) that pushes the tension pulley (5) on the V-belt (10).
5. Remove the V-belt (10).
6. Loosen the bolt (6) from the pulley (7) and remove it with proper device (e.g. pulley puller).

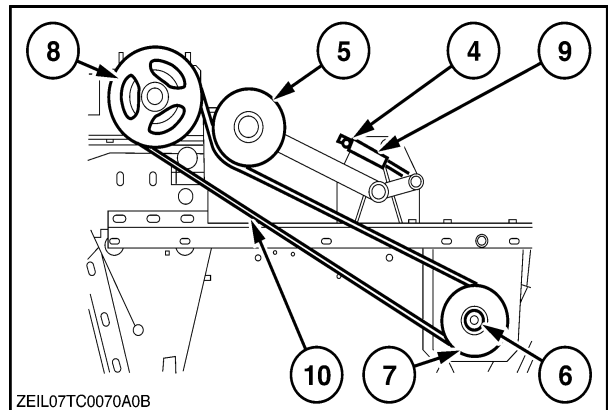

181

7. Remove the knob (1) with nut (see fig. 174).
8. Remove the bushes (2), washer (3) and spring (1).

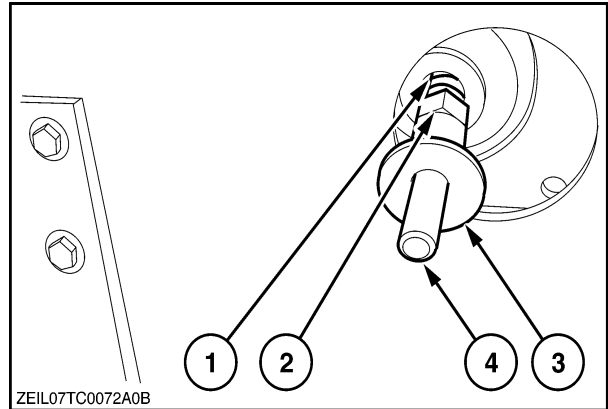

182

9. Remove the shaft (4) from the inside.

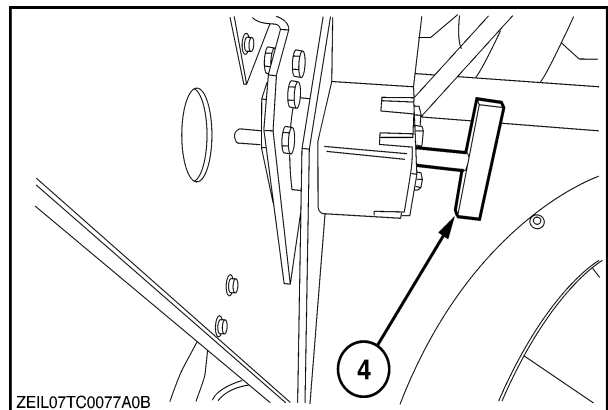

183

SECTION 3 – FIELD AND SITE OPERATION

⚠ WARNING ⚠

Due to its weight, 95 kg (210 lbs), you have to secure the chaff spreader with adequate lifting device.

10. Use wooden blocks (1) to not damage the spreader when you remove it.

11. Loosen the three bolts (1) and nuts on the side of the pulley.

12. Loosen the three bolts (2) and nuts on the side of the knob. Now your spreader can move freely.

13. Lower the spreader a little so you can turn it diagonally backwards with the right side first.

14. Remove the shaft (1) from the pulley hole (2) on the left side. Rotate the spreader 90° backwards.

15. Now you can remove the spreader from under the combine.

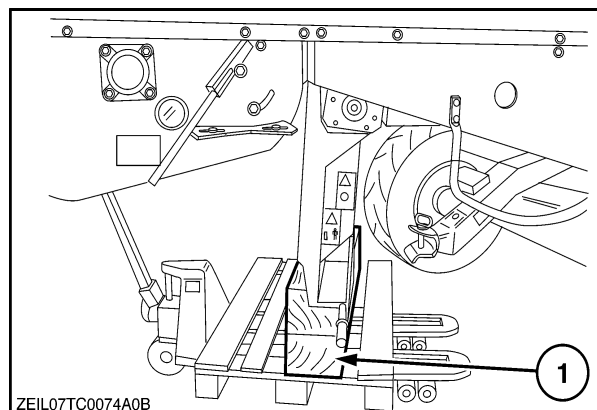

184

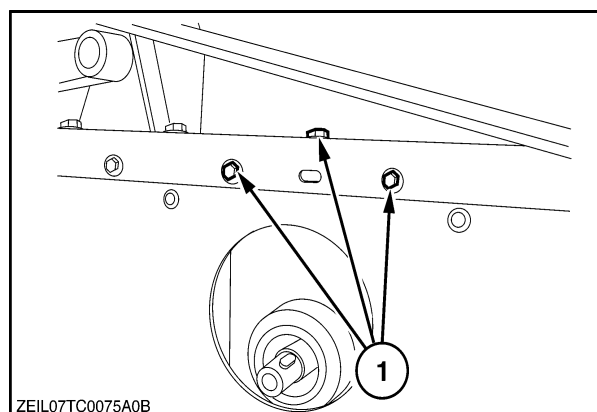

185

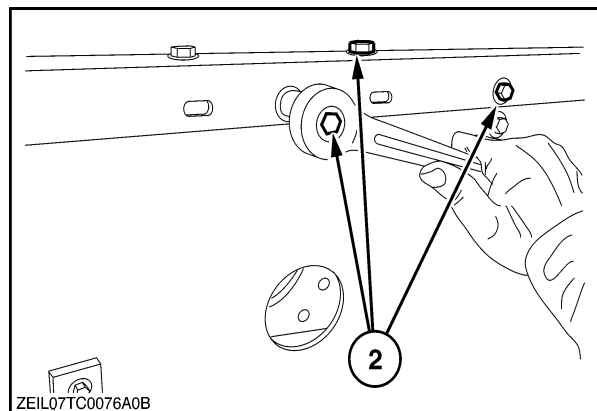

186

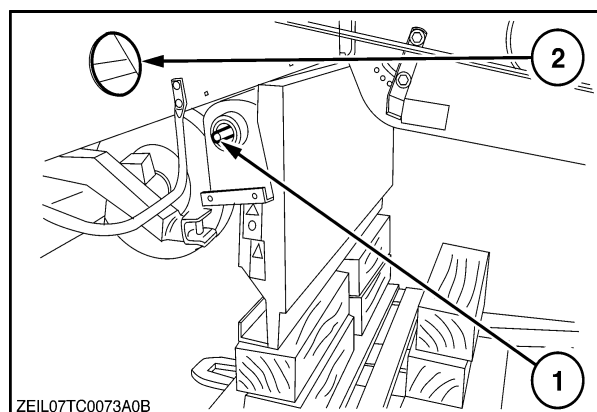

187

SECTION 3 – FIELD AND SITE OPERATION

To install, proceed as follows:

1. Make sure that the two brackets are vertical to bolt them back in position (see fig. 185 & 186).
2. Redress the spreader with 90° on the wooden blocks (1).

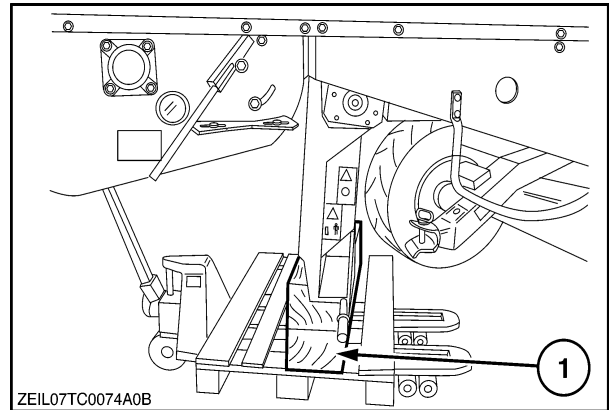

188

3. Move the axle (1) from the pulley diagonally back through its hole (2).
4. Lift the spreader at the right level in such a manner that you can bolt the brackets to the chassis of your combine.

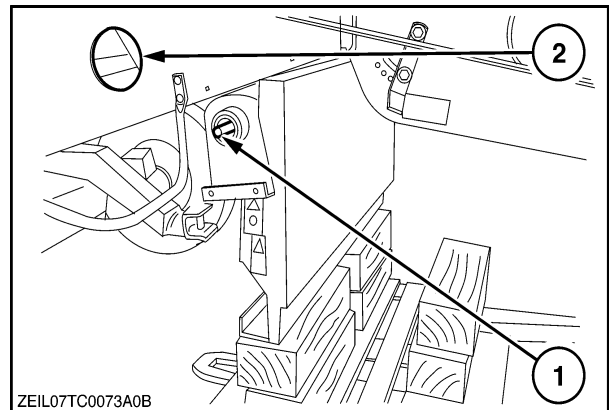

189

5. Install the shaft (4) from the backside, (see fig. 183), the spring (1), the bushes (2) and the washer (3) in between the knob (1).

IMPORTANT: Be sure not to tighten too much the nut otherwise you can't move your spreader anymore due to a lack of displacement.

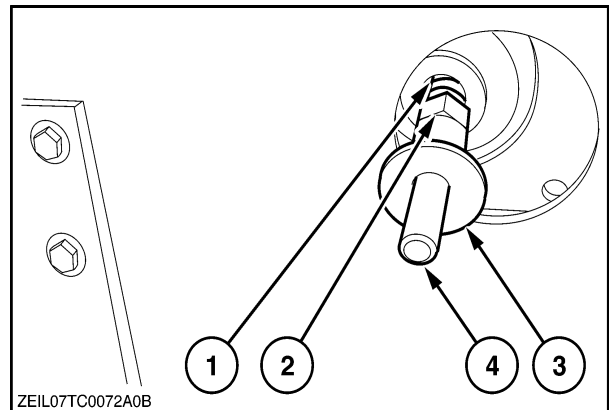

190

SECTION 3 – FIELD AND SITE OPERATION

6. Remount the chaff spreader drive pulley (8) on the axle and secure it with the bolt (6).
7. Install the V-belt (10) back on the pulleys and place the tension pulley (5) again on the belt.
8. Install the spring (9) back under tension by tightening the nut (4).

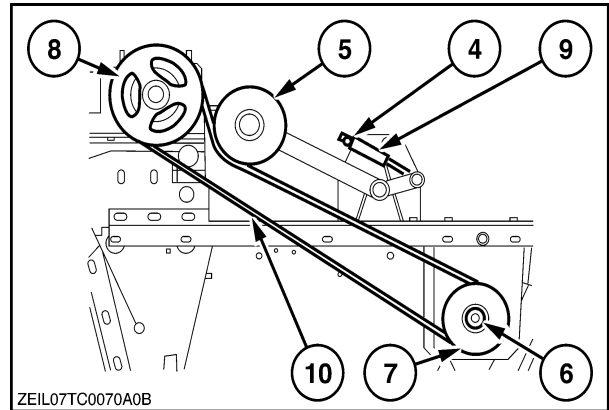

191

9. Install the protection cover (1) with all the bolts (2) and (3).

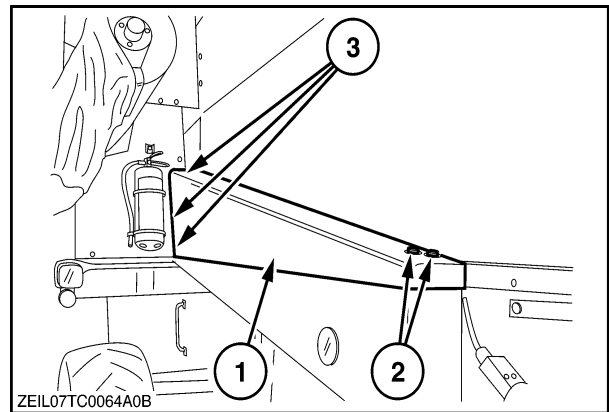

192

SECTION 4 – LUBRICATION AND MAINTENANCE

GENERAL

Your combine is designed to require minimum lubrication and maintenance. However, regular lubrication and maintenance is the best insurance against delays and repairs and greatly increases the life of the machine.

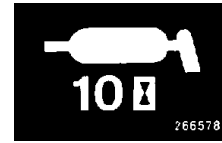

Use only top grade lubricants stored in clean vessels.

Recommended lubricants and amounts are summarized at the end of this section.



Always stop the machine before lubricating and observe following precautions:

- Disengage all drives
- Engage the parking brake
- Raise the header
- Engage the header safety latch
- Switch off the engine
- Remove the ignition key before leaving the operator's platform

GREASE FITTINGS AND INTERVALS

Before greasing the machine always wipe any dirt from the grease fittings.

All points, except those with special notations, should be lubricated with **maximum 3 strokes** of greasing gun and then the excess grease should be wiped off.

NOTE: After greasing, shift the variators from minimum to maximum and vice versa to distribute the grease in the hub.

Grease specification

Use Multipurpose grease AMBRA GR9 (ref. NH710A) or AMBRA GR75MD (ref. NH720A), or grease classified under NLGI 2.

SECTION 4 – LUBRICATION AND MAINTENANCE

10 hours interval (daily) – left-hand side

1. Straw elevator top shaft bearing

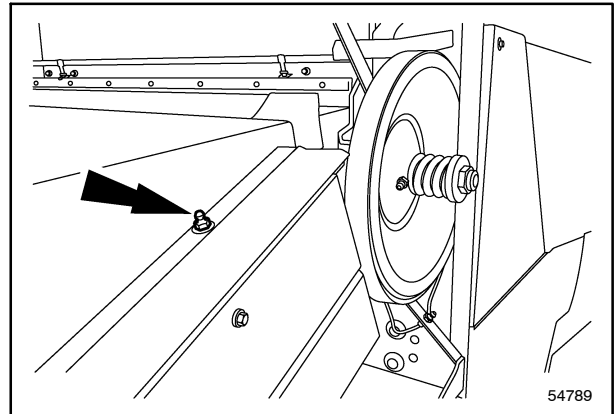

1

2. Unloading tube swivel ring (4 grease fittings)

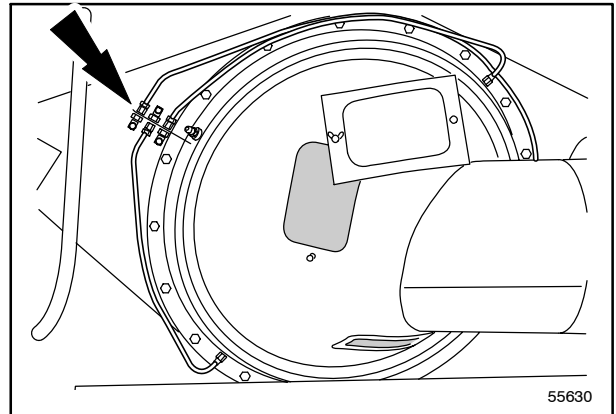

2

3. Engine tail shaft
(max. 2 gun strokes each grease time)

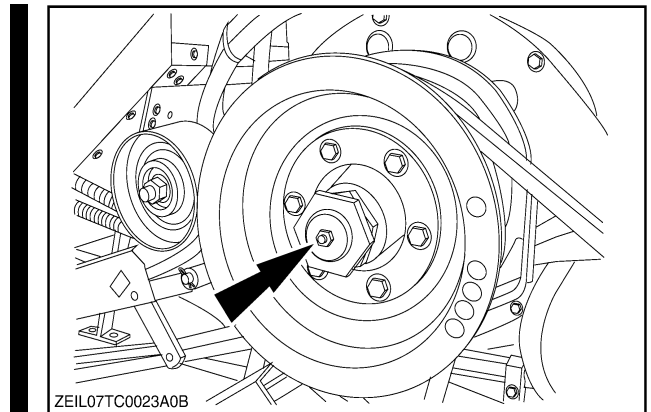

3

DELETED

10 hours interval (daily) – right-hand side

DELETED

1. Drum variator (*)
Floating disc on beater shaft

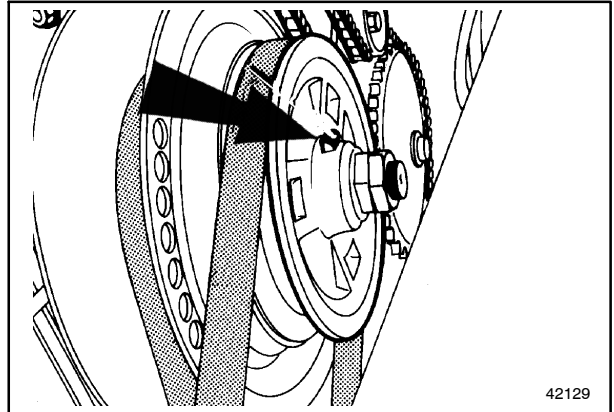

4

2. Drum variator (*)
Thrust bearing on beater shaft
Thrust bearing on drum shaft

(*): after greasing, shift the variator from minimum to maximum position and vice versa.

DELETED

3. Drum variator (*):
Floating disc on drum shaft
Thrust bearing on drum shaft

(*): after greasing, shift the variator from minimum to maximum position and vice versa.

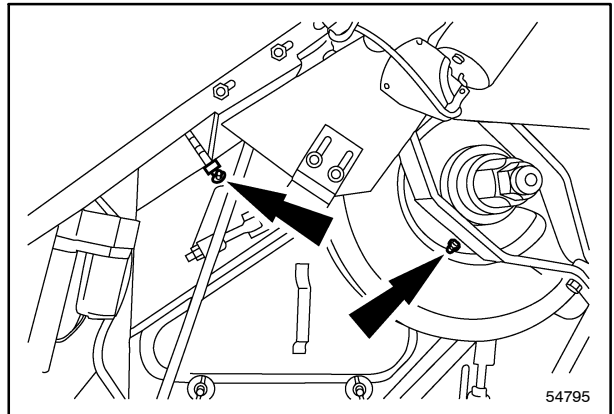

5

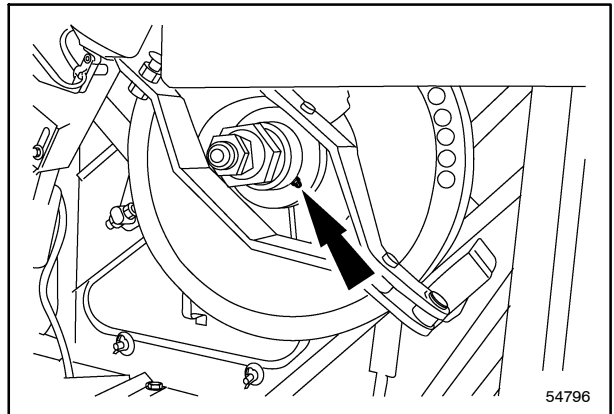

6

4. Straw elevator top shaft bearing

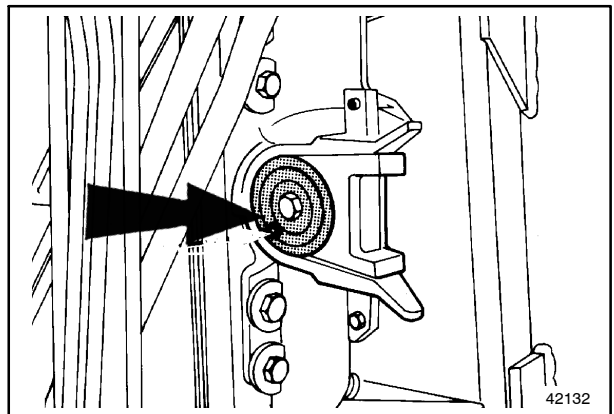

7

SECTION 4 – LUBRICATION AND MAINTENANCE

5. Cleaning fan variator disc (*)

(*): after greasing, shift the variator from minimum to maximum position and vice versa.

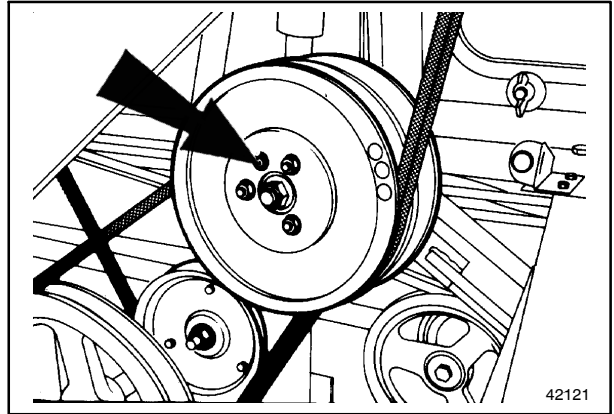

8

50 hours interval – left-hand side

1. Unloading auger (3 grease fittings)
Accessible through covers (*)

(*): Grease with the unloading tube in closed position.

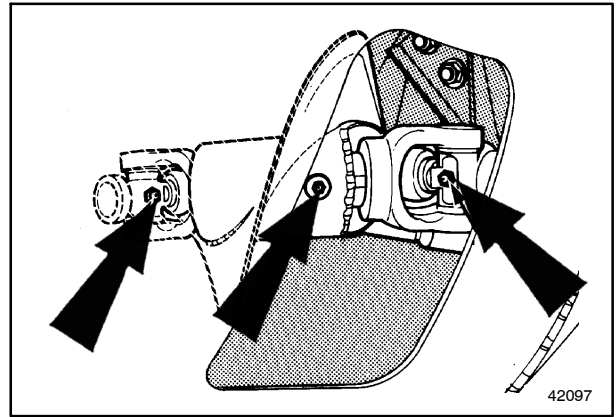

9

2. Straw chopper (if installed)
idler pulley pivot points (2X)

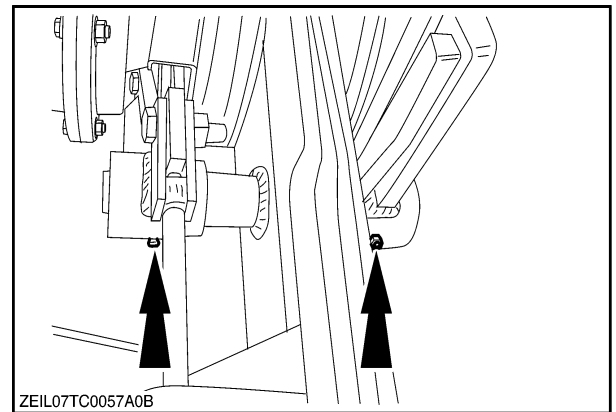

10

3. Cleaning fan bearing

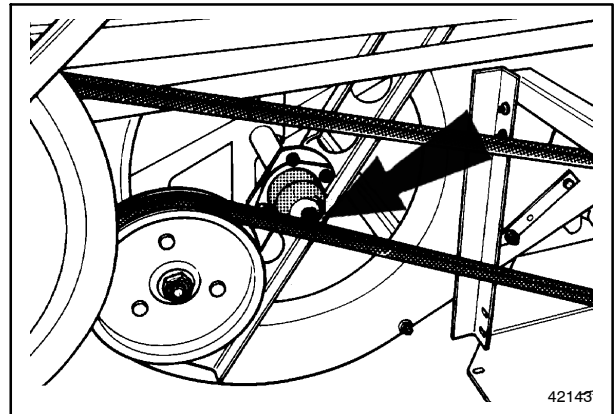

11

4. Traction variator sheave (mechanical drive)

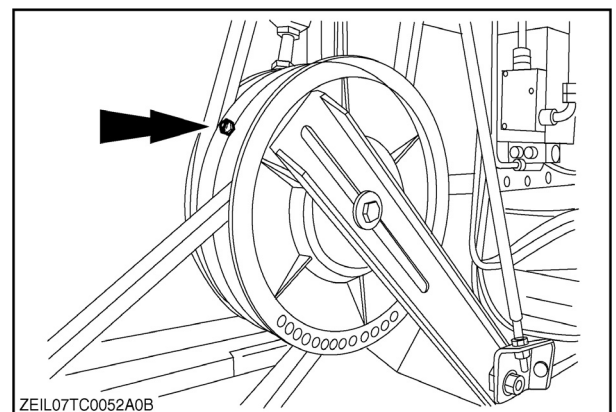

12

SECTION 4 – LUBRICATION AND MAINTENANCE

5. Main drive belt idler

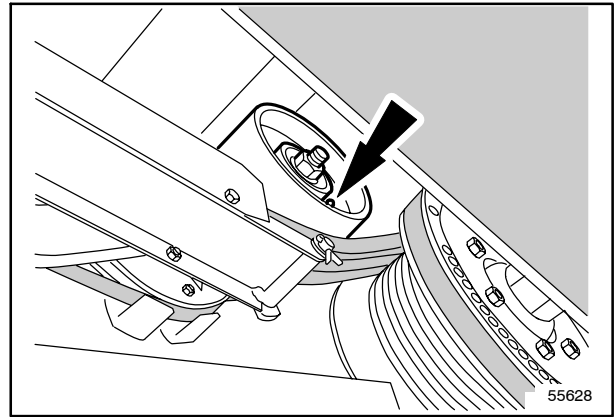

13

6. Cross augers drive slip clutch

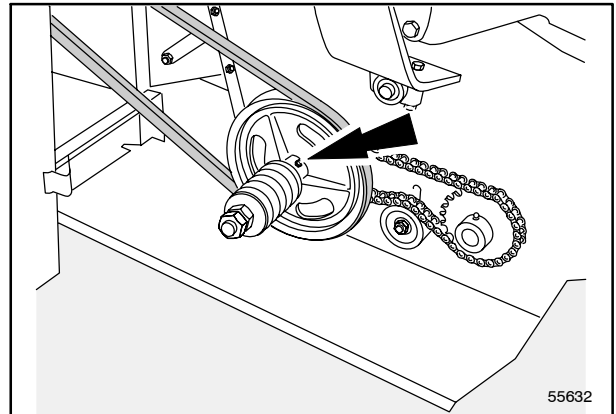

14

7. Steering wheel spindle (2 grease fittings)

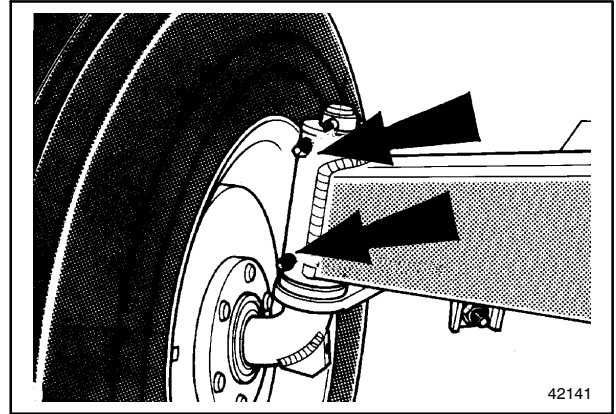

15

8. Eccentric shaft bearing

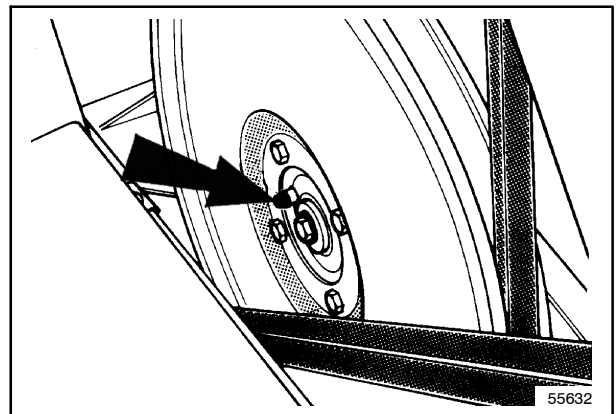

16

SECTION 4 – LUBRICATION AND MAINTENANCE

- 9. Straw elevator slip clutch
Straw elevator pivot point

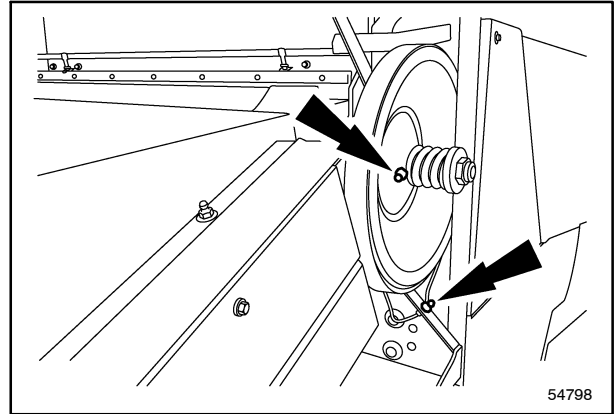

17

- 10. Straw walker rear shaft bearing

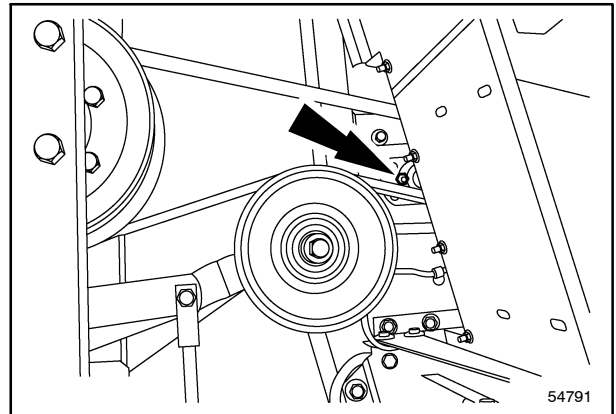

18

- 11. Straw walker front shaft bearing
(mechanical drive)

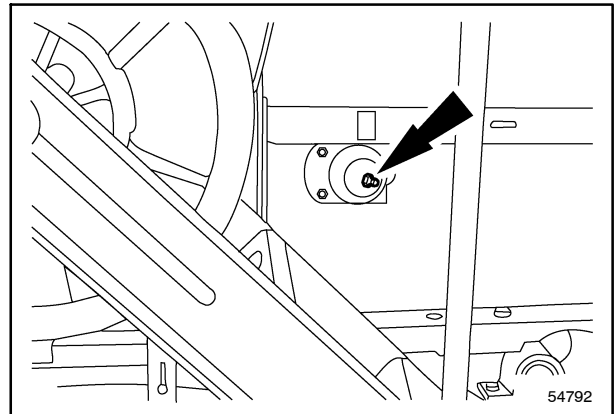

19

- Straw walker front shaft bearing
(hydrostatic drive)

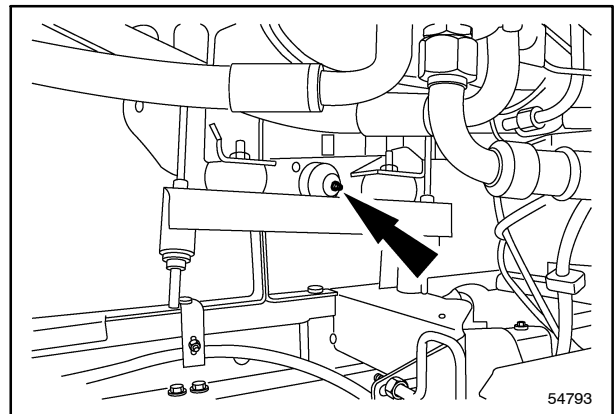

20

50 hours interval – right-hand side

1. Drum variator: nuts on threaded rod (2 grease fittings)

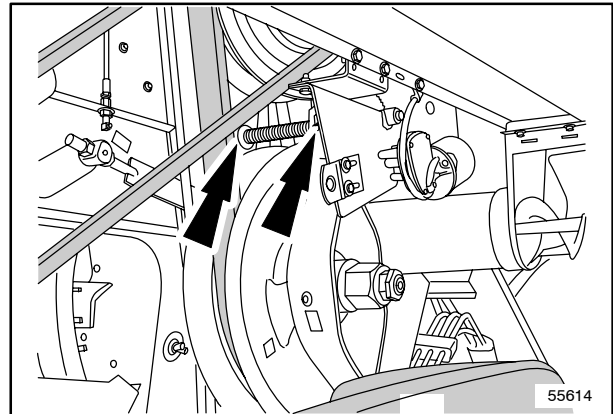

21

2. Gearshift linkage (2 grease fittings)

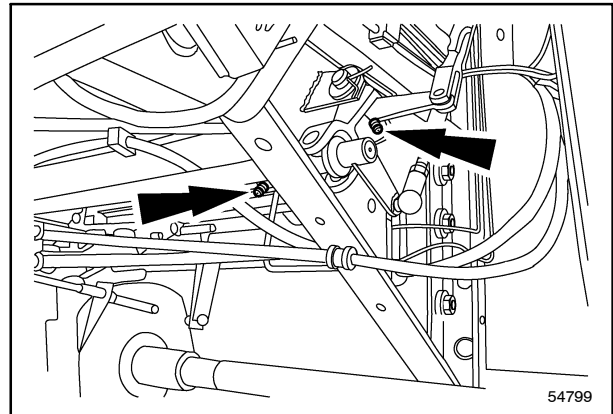

22

DELETED

3. Straw elevator pivot point

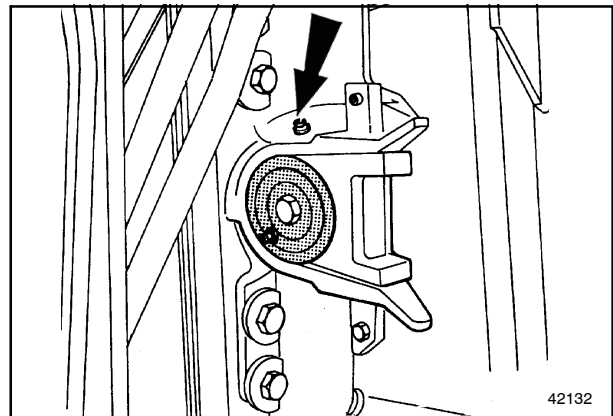

23

4. Cleaning fan bearing

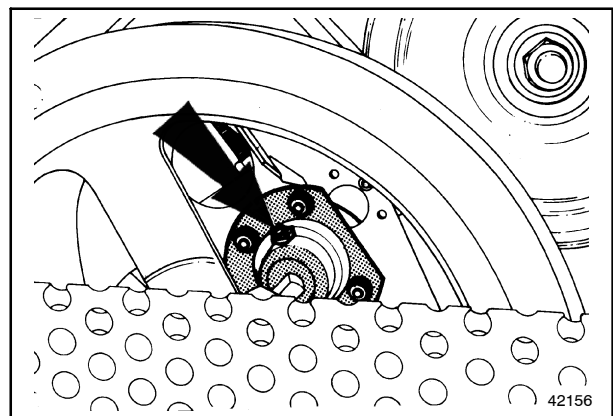

24

SECTION 4 – LUBRICATION AND MAINTENANCE

5. Eccentric shaft bearing

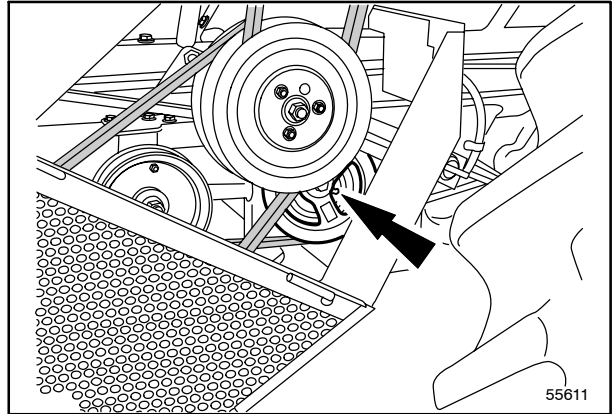

25

6. Cross auger bearings (2 grease fittings)

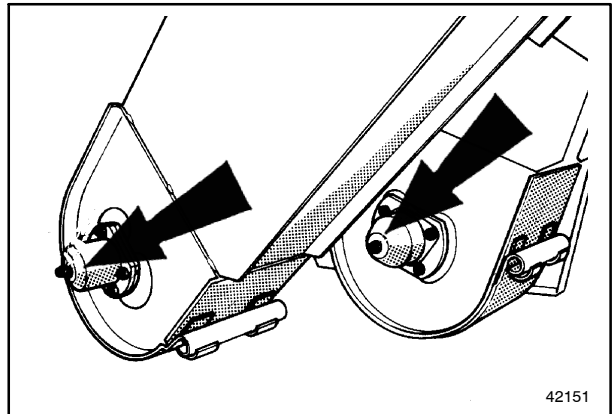

26

■ 7. Straw walker front shaft bearing

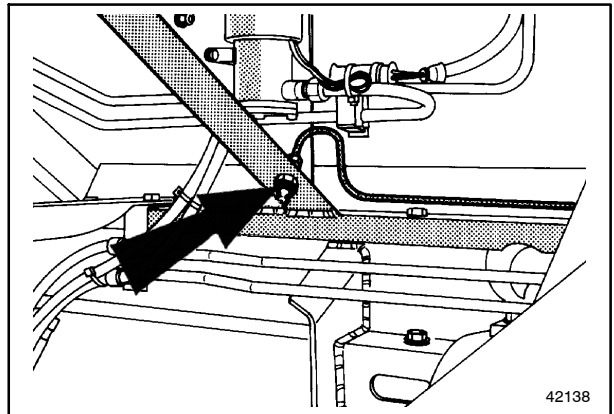

27

■ 8. Straw walker rear shaft bearing

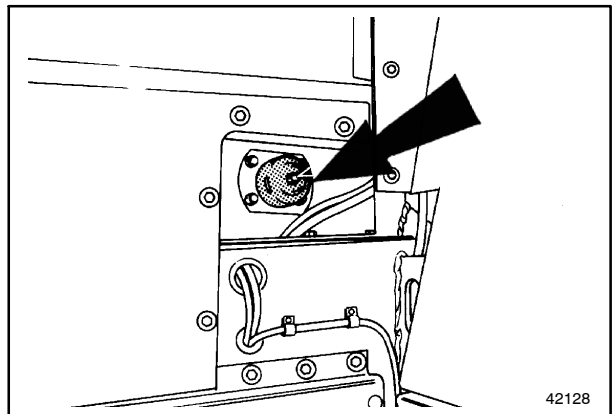

28

SECTION 4 – LUBRICATION AND MAINTENANCE

9. Steering wheel spindle (2 grease fittings)

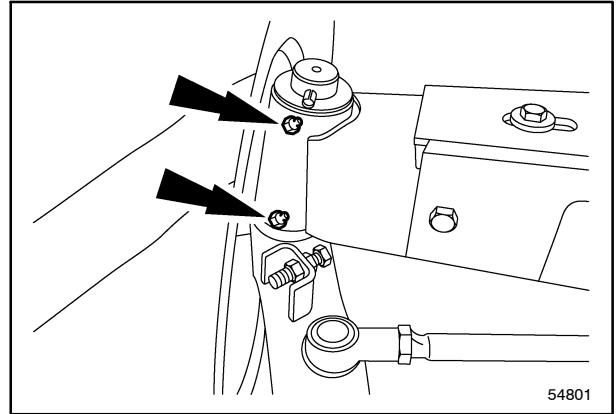

29

10. Steering axle pivot

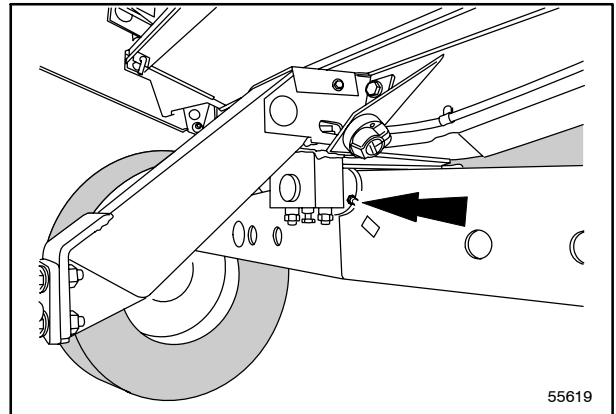

30

SECTION 4 – LUBRICATION AND MAINTENANCE

100 hours interval – left-hand side

1. Final drive shaft connecting sleeve
(2 grease fittings)

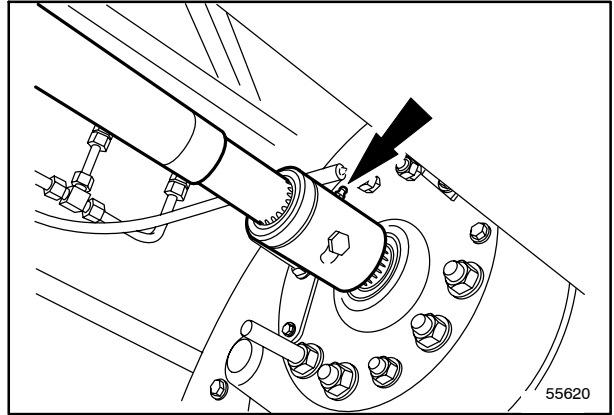

31

2. Unloading tube cylinder bottom joint

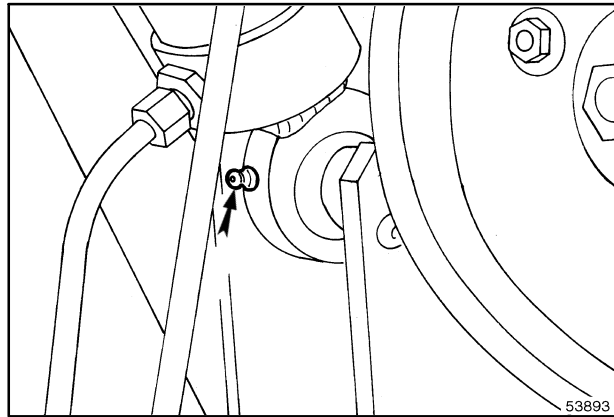

32

3. Unloading tube cylinder top joint

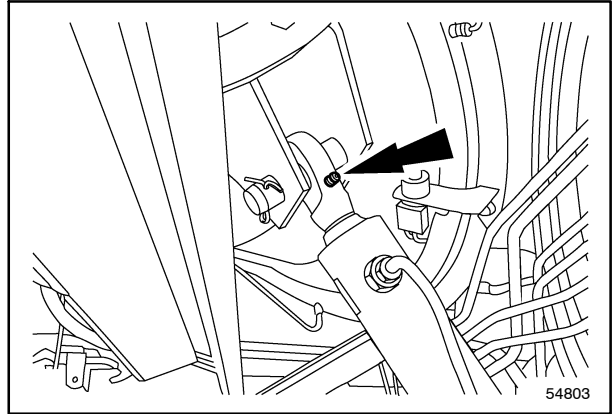

33

4. Rotation trailer hitch (if installed)

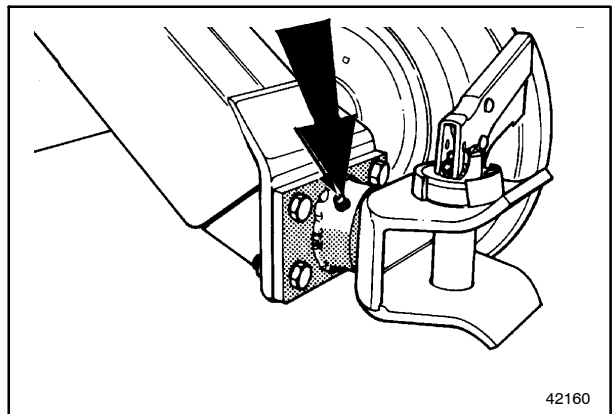

34

- 5. Chaff spreader gearbox (if installed)

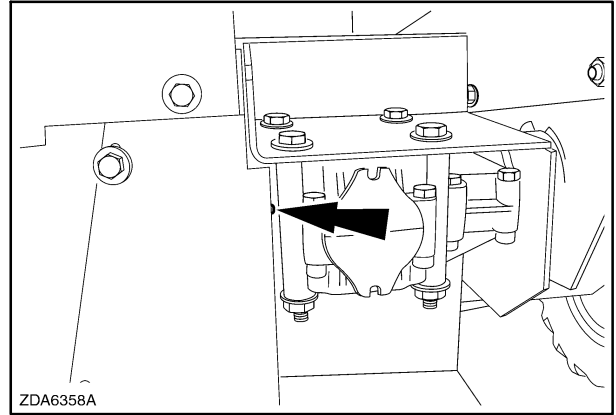

35

- 6. Clutch operating shaft (front) (mechanical drive) (view from underneath)

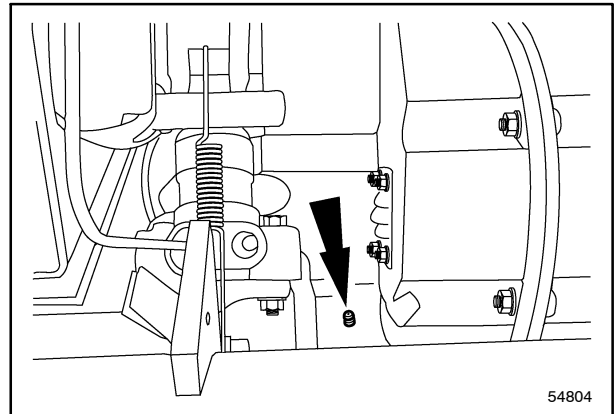

36

- 7. Clutch operating shaft (rear) (mechanical drive)

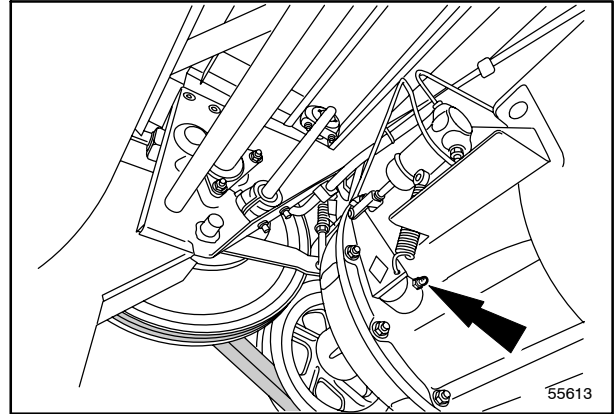

37

100 hours interval – right-hand side

- 1. Final drive shaft connecting sleeve (2 grease fittings)

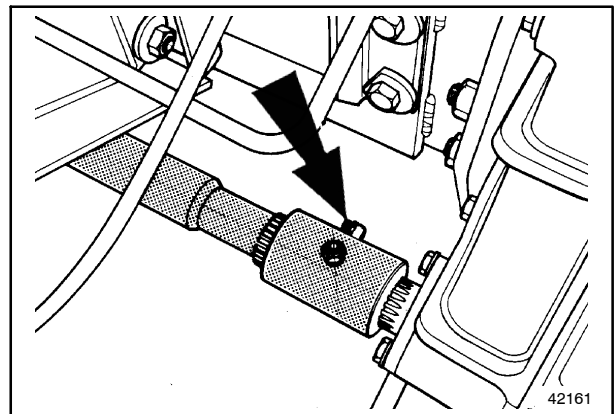

38

ENGINE

IMPORTANT: Clean the engine area, the radiator compartment and, in particular, the exhaust system daily to prevent fire hazards. When operating in extremely dry crops and in heavy dust conditions, check these areas more often and clean, if necessary.

■ Oil level

Check daily the oil level by the dipstick (1) with combine parked on level ground.

1. Remove the dipstick (1), wipe clean and re-insert fully.

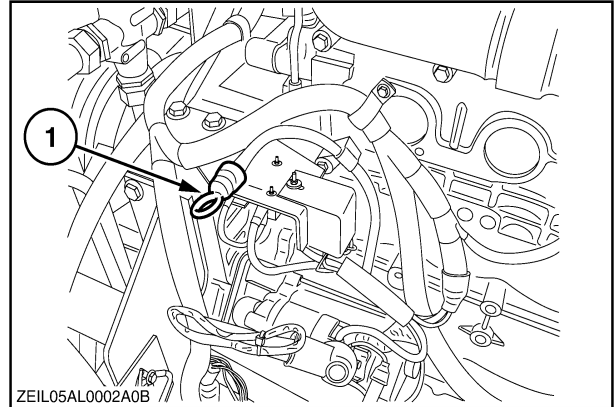

39

2. Pull the dipstick out again and check the oil level. The oil level should be between the minimum and the maximum mark.

IMPORTANT: At no time should the oil level be allowed to fall below the minimum level.

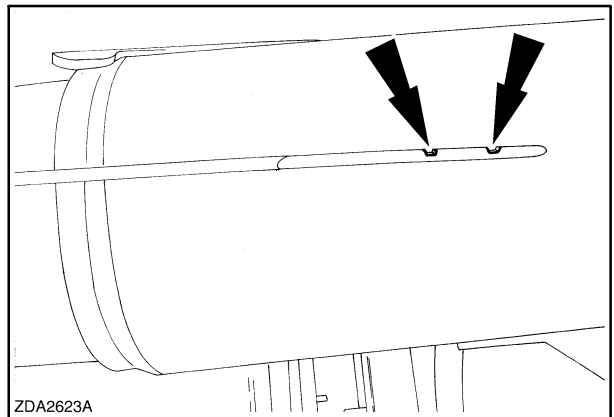

40

3. If required, top the oil up through the filler hole (2), until the oil level reaches the maximum level on the dipstick (fig. 40).

IMPORTANT: Do not fill above the upper mark on the dipstick. Excess oil will burn off, create smoke and give a false impression of oil consumption.

- TC5040 – TC5050 – TC5060: fig. 41
- TC5070 – TC 5080: fig. 42

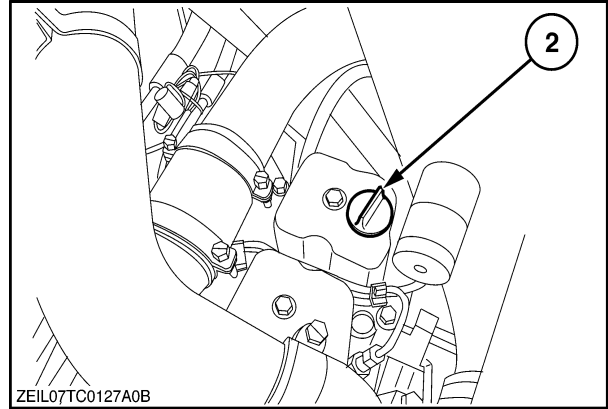

41

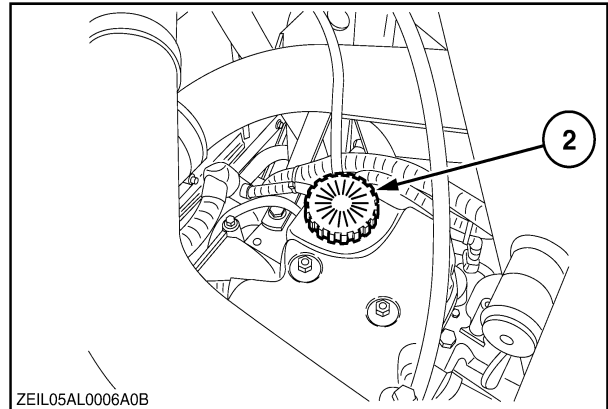

42

Engine sump and filter capacity (total)

16 litres (4.23 US gal)

Oil and filter change

Every 600 hours or annually

The engine oil filter(s) should be changed every time the oil is changed.

To change the oil and filter, proceed as follows:

1. Warm the engine to operating temperature. Stop the engine, drain the oil through the drain hose (3) and catch the oil in a suitable container.

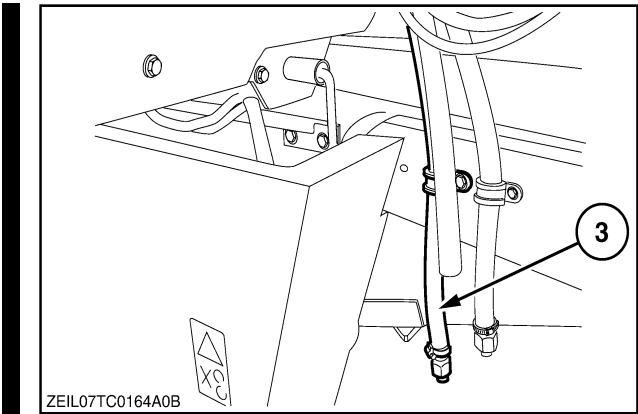

43

2. Clean the area round the engine oil filter and remove the “spin-on” filter (1) which is situated on the right-hand side.
3. Fill up the new filter with clean oil and apply an oil film to the seal ring.
4. Screw on the new filter by hand. Tighten firmly WITHOUT USING TOOLS!
5. Reinstall the plug of the drain hose (3). (fig. 43).

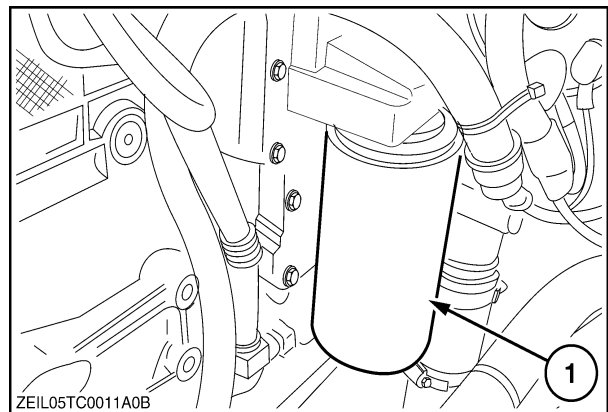

44

6. Remove the filler cap (2) and refill the engine with clean oil. Re-install the filler cap. Refer to paragraph headed (oil specifications)
7. Start the engine at low idle for a minute or so, to circulate the oil, then stop the engine.
8. Wait for a short period to allow the oil to drain back to the sump. Check the oil level on the dipstick as explained in previous paragraph headed: “Oil level”.
9. Start the engine and check for possible leaks.

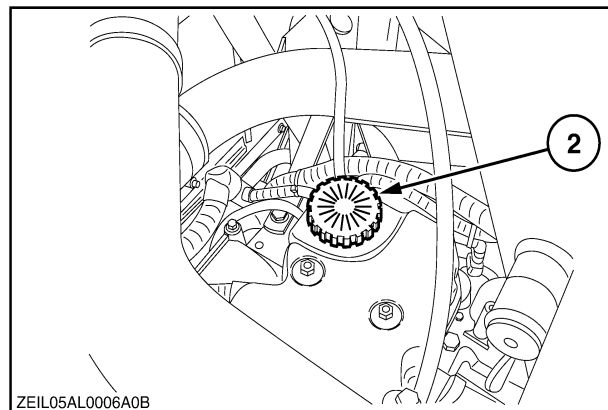

45

Oil specification

Use AMBRA MASTER GOLD HSP, SAE15W40, NH330H engine oil or an oil meeting the following specifications:

- API CH-4 or ACEA E3/E5

ENGINE COOLING SYSTEM

Coolant level

Check the coolant level daily in the shunt tank when the engine is cold. The coolant level should reach the level indicator (2).

IMPORTANT: Under no circumstances should the engine be started without coolant in the cooling system.



The cooling system operates under pressure which is controlled by the pressure/filler cap (1). Take care if removing the pressure/filler cap while the system is hot. Cover the cap using a thick cloth and open the pressure/filler cap slowly and allow the pressure to escape before removing the cap completely. Do not add cold water to a hot shunt tank.

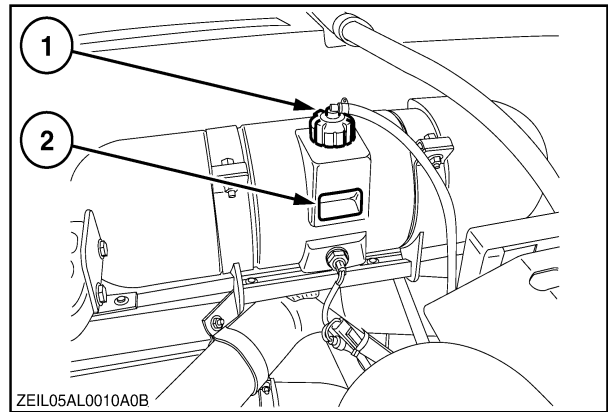

46

When the coolant level is too low, proceed as follows:

1. Run the engine at low idle.
2. Add coolant to the cooling system through the shunt tank filler opening (1). Never fill when the engine is hot.

Coolant change

The coolant should be renewed:

- Every 2 years.

When replacing the coolant proceed as follows:

1. Drain the coolant by opening the stopcock (3) at the bottom of the radiator.
2. Flush the cooling system with clean water. (steps 3 to 6).
3. Close the stopcock (3) and fill the cooling system with clean water through the shunt tank filler opening (1) (fig. 46).
4. Start the engine and run it at low idle until the water temperature is at normal operating temperature.
5. Stop the engine.

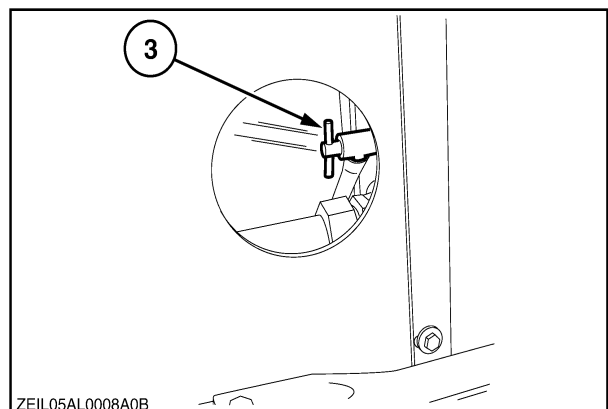

47

6. Drain the water by opening the stopcock (3).
7. Close stopcock and fill the cooling system with coolant as specified.

IMPORTANT: Always fill the cooling system with an approved antifreeze/water mixture. Check the freezing point of the coolant after each refill.

— **⚠ CAUTION ⚠** —

The engine is hot and so may be the shunt tank. Extreme care should be taken when filling the cooling system.

8. Start the engine and run it at 1500 rpm until the coolant temperature is at normal operating temperature.
9. Return to low idle and stop the engine after 1 minute (Turbo charger precaution).
10. Fill the shunt tank to the level indicator (2) and install the pressure/filler cap (1).

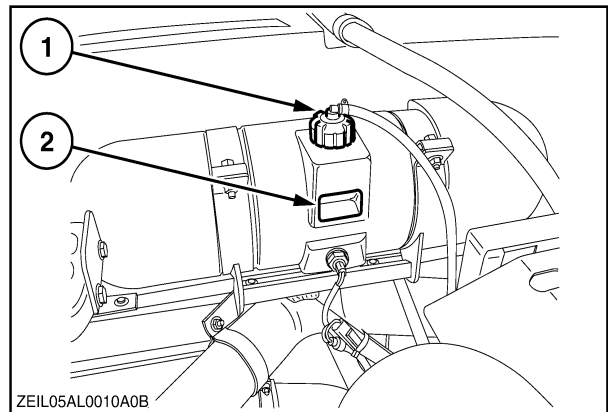

Coolant system capacity

38 litres (10 US gal)

Coolant specification

The coolant is a water/antifreeze mixture containing:

- 50% water
- 50% antifreeze: AGRIFLU (ref. NH900A)

The quality of the water should not exceed following limits:

- Total hardness: 0.3%
- Chlorides: 0.1%
- Sulphates: 0.1%

Fuel tank drain plug

The fuel tank is fitted with a drain plug 1.

Fuel prefilter / water separator

A prefilter/water separator (2) is fitted in the fuel intake tube, under the fuel tank.

Drain the water from the prefilter/water separator (2) daily, proceed as follows:

1. Loosen the screw (3) to allow the water to run out of the screw orifice.
2. Collect the water/fuel mixture and dispose according to regulations.
3. Tighten the screw (3) when fuel free of water runs out of the screw orifice.

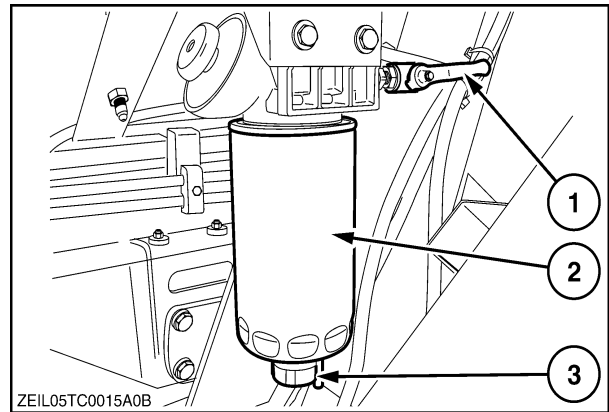

49

The fuel prefilter/ water separator (2) should be changed every 300 operating hours, or earlier, if a drop in engine performance is experienced.

To change the prefilter/water separator, proceed as follows:

1. Wipe the top of the prefilter/water separator head clean.
2. Close the tap (1).
3. Unscrew the "spin-on" prefilter/water separator, using a filter wrench.
4. Fill the new prefilter/water separator with clean fuel and apply a film of fuel to the gasket.
5. Screw on the new prefilter/water separator by hand. Tighten firmly, but do not use tools.
6. Open the tap (1).

Check for possible leaks. If required, tighten the prefilter / water separator.

7. Bleed the fuel system (refer to paragraph headed "Bleeding the fuel system").

SECTION 4 – LUBRICATION AND MAINTENANCE

Fuel filter

The fuel filter (3) should be replaced every 300 operating hours.

To change, proceed as follows:

1. The fuel filter is accessible by removing the covers (1) and/or (2) in the grain tank.
2. Clean the top of the filter head.
3. Unscrew the "spin-on" fuel filter, using a filter wrench.
4. Fill a new fuel filter with clean fuel and coat the seal with fuel. Make sure the seal is properly seated.
5. Screw the new filter by hand and tighten firmly, without using tools.
6. Bleed the fuel system (see the next paragraph).

- TC5040 - TC5050 - TC5060: one filter (fig. 52)
- TC5070 - TC5080: two filters (fig. 51)

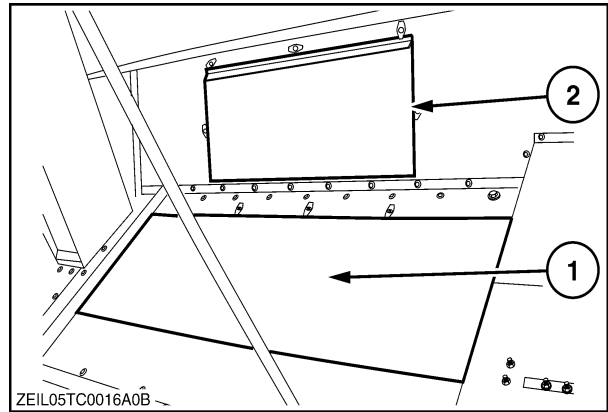

50

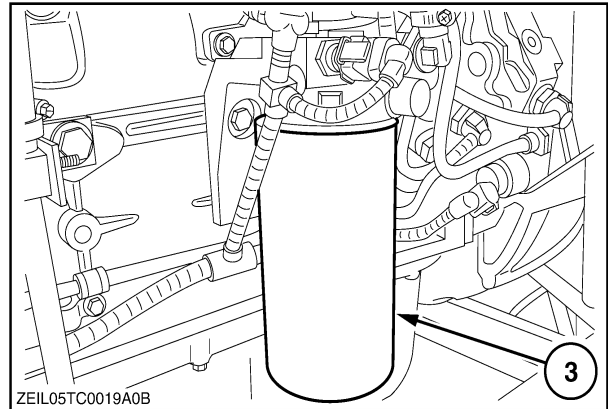

51

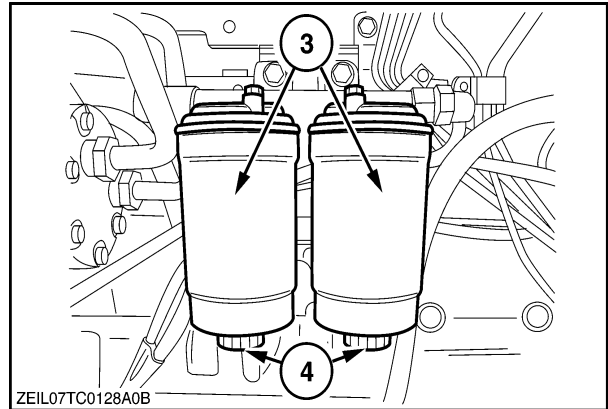

52

Bleeding the fuel system (TC5040 - TC5050 - TC5060)

To bleed the fuel system, proceed as follows:

NOTE: This job needs to be carry out with two people.

1. Ensure there is fuel in the fuel tank and the tap (1) is open.
2. Loosen both bleed screws on top of the fuel filters (3) to allow the air to escape.

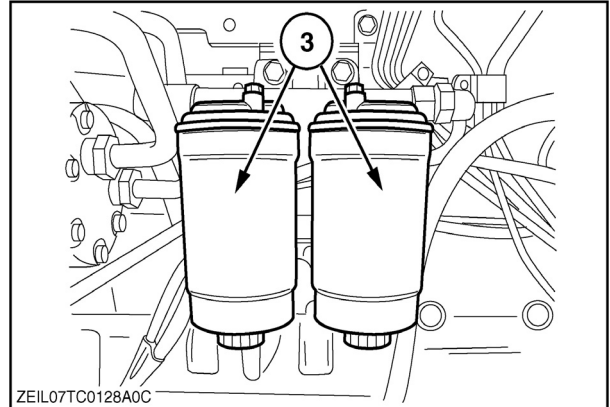

ZEIL07TC0128A0C

53

3. On top of the water separator (2) is fitted a primer pump (4) which is used to prime the injection pump with fuel when the filter element has been changed.
4. Tighten the bleed screws when fuel free of air bubbles escapes.
5. Continue pumping until the force needed remains more or less constant.
6. Start the engine.

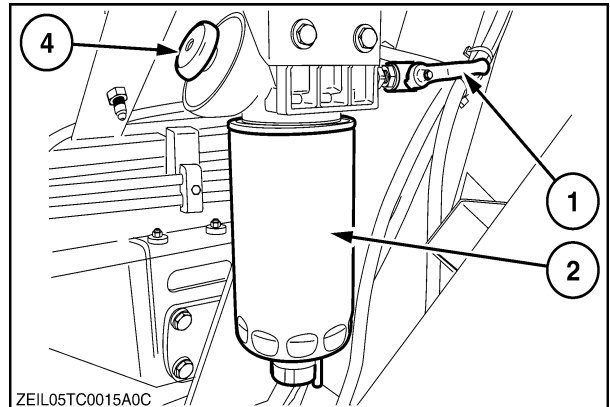

ZEIL05TC0015A0C

54

7. Run the engine at low idle until the engine runs smoothly.

Bleeding the fuel system (TC5070 - TC5080)

To bleed the fuel system, proceed as follows:

1. Ensure there is fuel in the fuel tank and the tap (1) is open.
2. On top of the water separator (2) is fitted a primer pump (4) which is used to prime the injection pump with fuel when the filter element has been changed.
3. Continue pumping until the force needed remains more or less constant.
4. Start the engine.

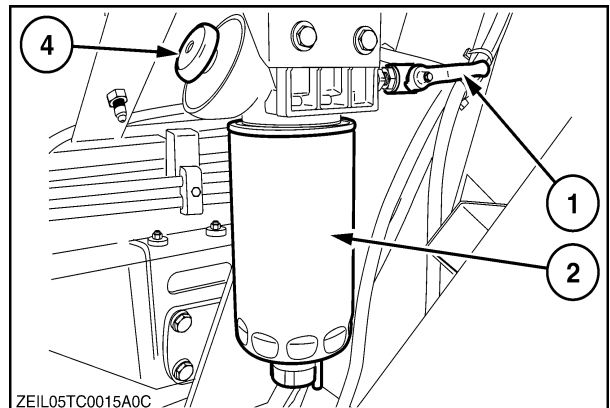

ZEIL05TC0015A0C

55

5. Run the engine at low idle until the engine runs smoothly.

Fuel specification

The quality of fuel used is an important factor in obtaining dependable performance and satisfactory engine life.

Fuels must be clean, well-refined and non-corrosive to fuel system parts. Be sure to use fuel of a known quality from a reputable supplier.

To be sure that a fuel meets the required properties, enlist the aid of a reputable fuel oil supplier. The responsibility for clean fuel lies with the fuel supplier as well as the fuel user.

Fuel type	Compatible
Arctic blend	Yes (Reduced durability)
Avtur/JP-8/Jet A/Jet A-1	No
Biodiesel (Din V51602 – UNI 10946 – EN 14214)	Maximum 20% blended in EN590 fuel: TC5070 - TC5080 Maximum 100% blended in EN590 fuel: TC5040 - TC5050 - TC5060
European diesel per EN590	Yes
Ultra low S sulphur Sweden fuel (Mk1)	Yes

Fuel storage

Many engine difficulties can be traced to dirty fuel, therefore the importance of using clean fuel, properly stored cannot be stressed too strongly.

■ ROTARY DUST SCREEN AND COOLING SYSTEM

The TC models are equipped with a hinged rotary dust screen door.

To gain access to clean the cooling system, proceed as follows:

- Open the rotary dust screen door by open the lock (1), using the handle (2).

Clean the cooling system regularly, depending on combining conditions.



Wear a dust mask when doing this job.

- Intercooler (1)
- Watercooler (2)
- Hydrostatic oil cooler (3)
- Air-conditioning condenser (4)

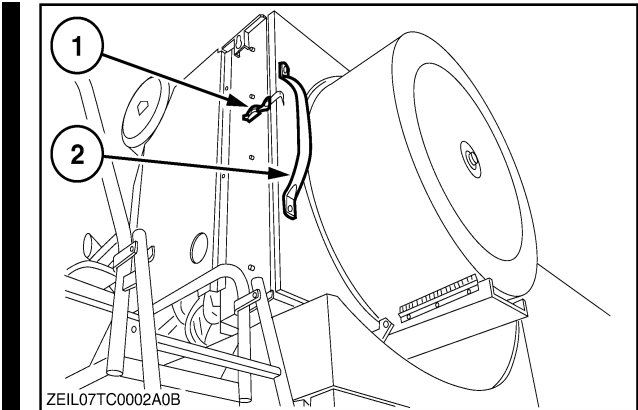

56

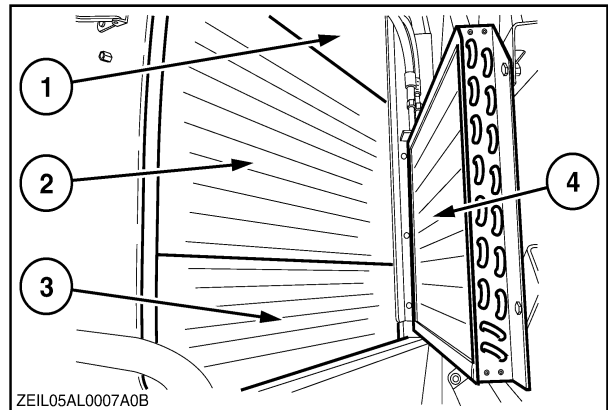

57

AIR INTAKE SYSTEM

The filter element should **only** be cleaned when the warning light in the combine cab illuminates and the audible alarm sounds (625 mm vacuum).

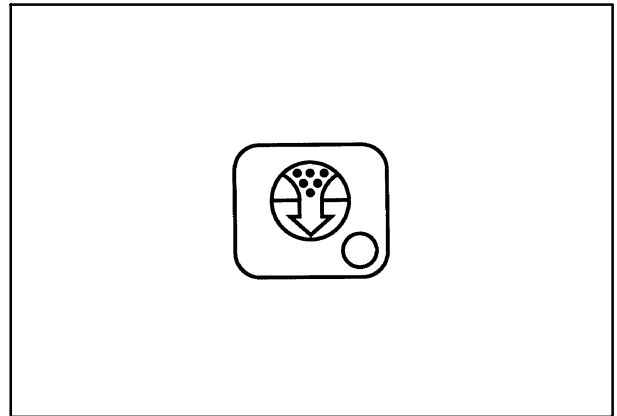

58

The air filter element (1) (fig. 60) should only be cleaned when there is an alarm on the monitor (625 mm) (24 - 5/8") vacuum.

To remove the air filter element, remove the cover (2) by loosening the clamps (3).

To clean the air filter element, hold the top and tap it against the palm of the other hand to remove the dust.

NEVER TAP IT ON A HARD SURFACE.

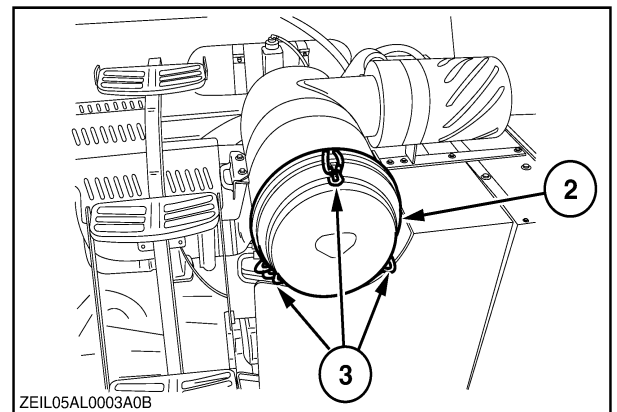

59

When tapping does not remove the dirt, direct compressed air through the element, from the inside towards the outside.

To prevent damage to the air filter element when cleaning with compressed air, take the following precautions:

- Maximum air pressure must be 5 bar (72,5 psi).
- Move the nozzle up and down when rotating the element.
- Keep the nozzle at least 25 mm (1") from the plated paper.

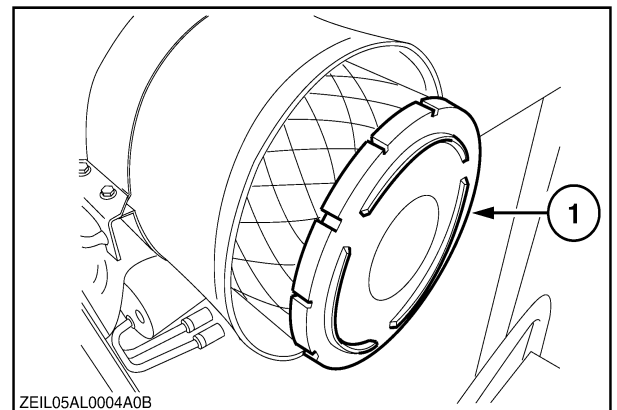

60

NOTE: To keep the interval acceptable is it high recommended to clean the air filter element with compressed air.

————— **⚠ WARNING ⚠** —————

Wear a dust mask when cleaning the air filter element.

If the element is soiled with oil or soot, it is possible to soak it for 15 minutes in a solution of 75 grammes (0,165 lbs.) of non-sudsy detergent and 10 litres (2,6 US gal) of lukewarm water.

Rinse the element thoroughly in clean water until the water remains clear and leave the element to dry.

NEVER WASH THE AIR FILTER ELEMENT IN PETROL OR DIESEL OIL.

Every time the air filter element is cleaned, it should be examined for holes and cracks by holding an electric light bulb inside the element and looking through it. If any damage is noted, discard the element and fit a new one.

Replace the air filter element after 10 cleanings or once a year, whichever comes first.

When fitting, make sure the element is seated properly and the sealing is in good condition.

A safety element (4) is fitted as an additional security to prevent dust from entering the engine when replacing the standard element.

————— **⚠ CAUTION ⚠** —————

The safety element should not be cleaned.
Replace the safety element every two years.

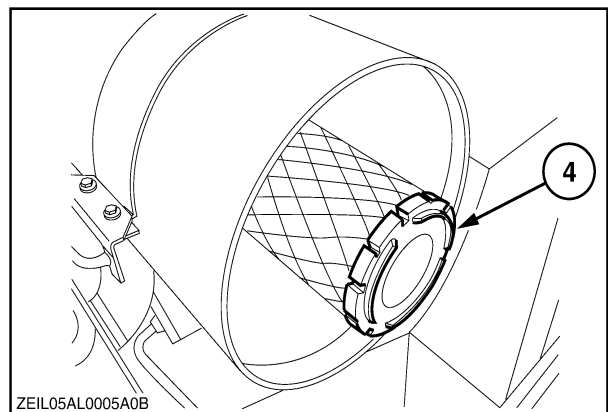

ZEIL05AL0005A0B

HYDRAULIC AND HYDROSTATIC SYSTEM

Oil reservoir

A single oil reservoir (1) is fitted for the hydraulic and hydrostatic system (if applicable). Both systems draw their oil from the same reservoir but the oil for each circuit goes through a separate filtering system.

- unit with mechanical drive (fig. 62)
- unit with hydrostatic drive (fig. 63)

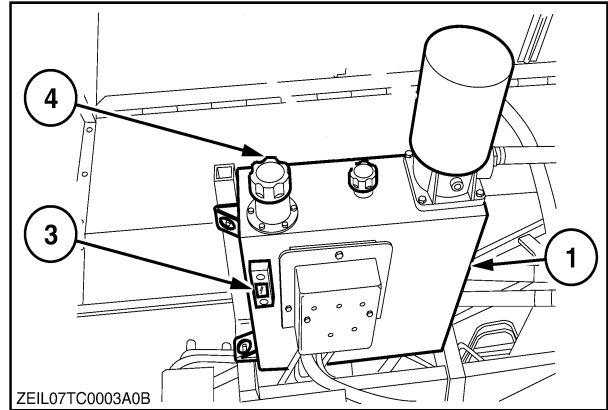

62

Oil level

NOTE: Ensure that all hydraulic cylinders are retracted before checking the oil level.

It is necessary to check daily the oil level by the level gauge (3) and should be kept between the marks. If necessary, add oil through the filler opening (4).

IMPORTANT: Always clean the reservoir filler cap (4) and surrounding area before removing the filler cap to top-up or replace the oil.

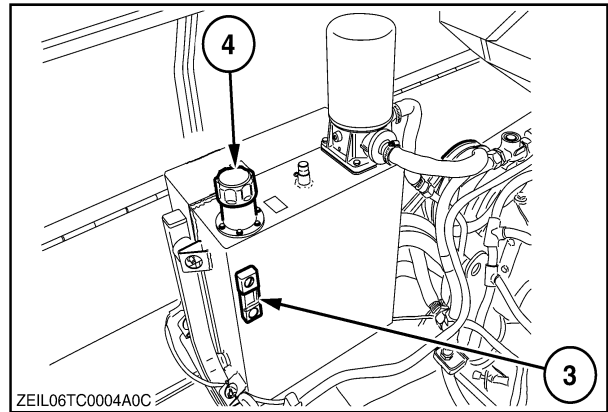

63

Oil and filter change

The hydraulic/hydrostatic oil and filters should be changed:

- Only filter after the first 100 operating hours
- Thereafter, every 600 operating hours or annually.

IMPORTANT: The return filter (5) (low pressure filter) should be changed at each oil change.

To change the oil and/ or the oil filters, proceed as follows:

• **All models**

1. Retract all hydraulic cylinders.
2. Thoroughly clean the surrounding area of the reservoir and the filters.
(with compressed air, if possible).
3. Remove the filler cap (4).

4. Drain the oil from the tank through the hose (2) and catch the oil in a suitable container.
5. Remove the “spin-on” return filter (5) with a filter wrench. (fig. 64)
6. Apply a film of oil to the gasket of the new return filter.
7. Screw the new filter by hand.
Tighten firmly **WITHOUT USING TOOLS**.

• **Only model TC5050 – TC5070 – TC5080**

8. Remove the hydrostatic filter (1).
9. Apply a film of oil to the gasket of the new oil filter and screw on the new filter by hand.

• **All models**

10. Reinstall the plug of the drain hose.

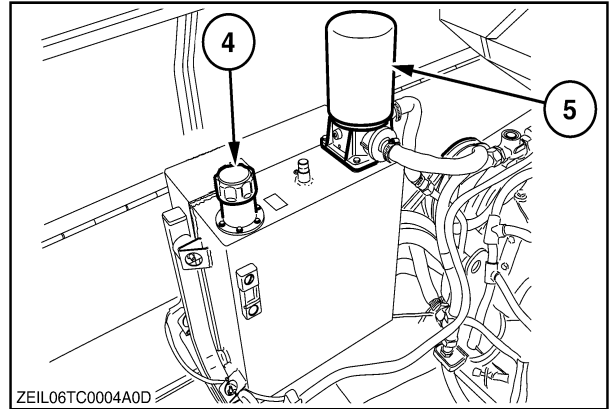

64

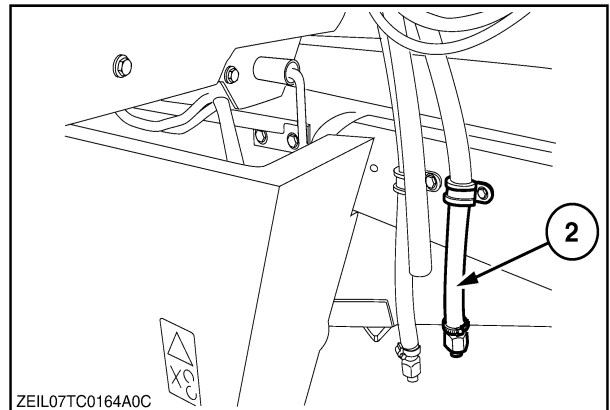

65

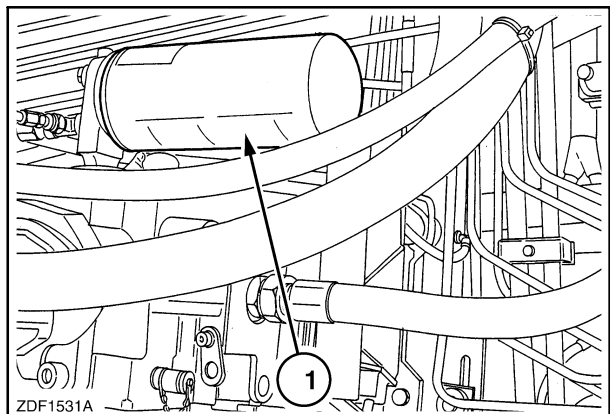

66

11. Fill the oil reservoir with hydraulic oil through the filler hole (4).
12. Check the oil level on the level gauge (3). This should be kept between the marks.

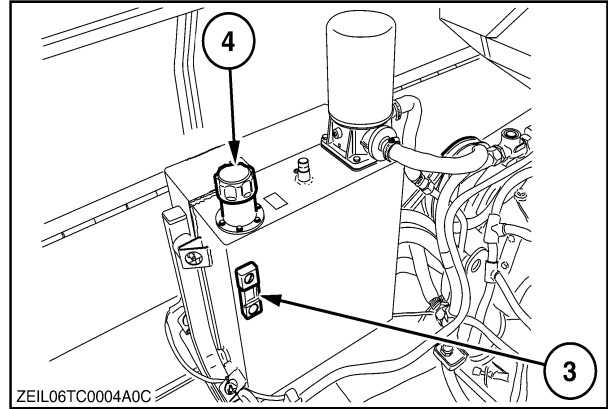

67

- **Only model TC5050 – TC5070 – TC5080**

13. Start the engine. When starting the engine, the buzzer in the cab should stop. The low pressure hydrostatic charge warning light must switch off as soon as the engine starts. If this is not the case, contact your dealer for assistance.

Run the engine at idle speed for five minutes and move the ground speed control lever slowly forward and rearward with the gearshift lever in neutral.

14. Check the oil level on the level gauge and, if required, add oil up to the maximum mark on the oil dipstick.

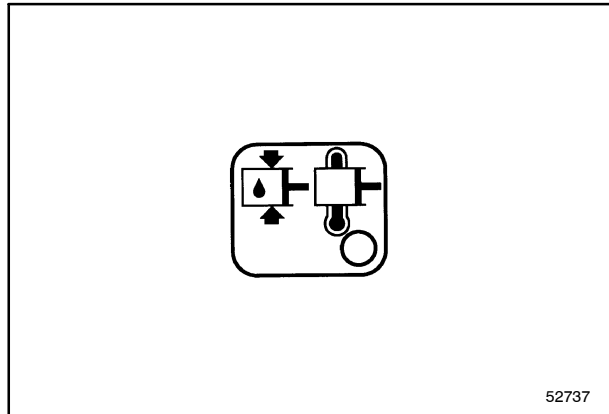

68

Oil capacity

TC5040 – TC5060: 20 litres

TC5050 – TC5070 – TC5080: 38 litres

Hydraulic oil specifications

Use AMBRA HYDROSYSTEM 46 (NH646H), AMBRA HYDROSYSTEM 46 BIO-S (re. NH646BS), AMBRA HYDROSYSTEM 46 BIO-V (re. NH 646 BV) hydraulic oil or an oil meeting the technical specifications here below:

- DIN 51524, part 2 or ISO VG 46
- Viscosity grade: HV 46

The hydraulic system is factory-filled with AMBRA HYDROSYSTEM 46 (NH646H) hydraulic oil. AMBRA HYDROSYSTEM 46 is a hydraulic oil with high viscosity grade; therefore, it remains fluid even at very low temperatures.



WARNING



The oil quality and cleanliness is of utmost importance for the reliability and life of the hydrostatic system. Deviation of the prescribed oil specification may lead to severe damage and void the warranty!

ACCUMULATOR

- Before disconnecting the accumulators for maintenance operations, it is necessary to reset the accumulator fluid pressure.
- The accumulator pressure check must be performed following the method recommended by the above accumulator manufacturer. It is necessary to make sure that the max. allowed accumulator pressure is never exceeded. After each check or adjustment, leaks should not be detected.

HYDRAULIC REMOTE CONTROL VALVES

Hydraulic valves located at the left-hand side of the combine.

• **Only if remote control**

1. Threshing
2. Unloading
3. Straw elevator

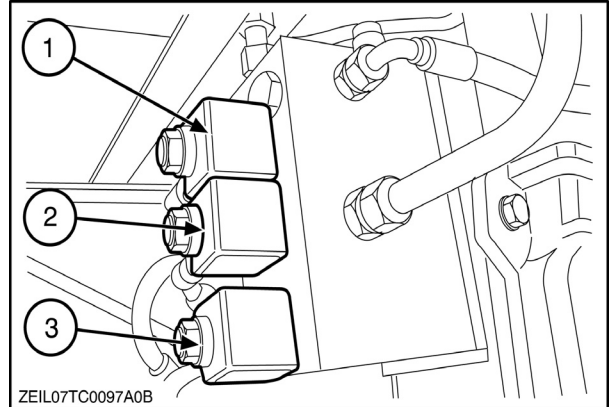

69

• **All models**

1. Lateral float
2. Reel for/after
3. Reel up/down
4. Unloading tube swing
5. Header up/down

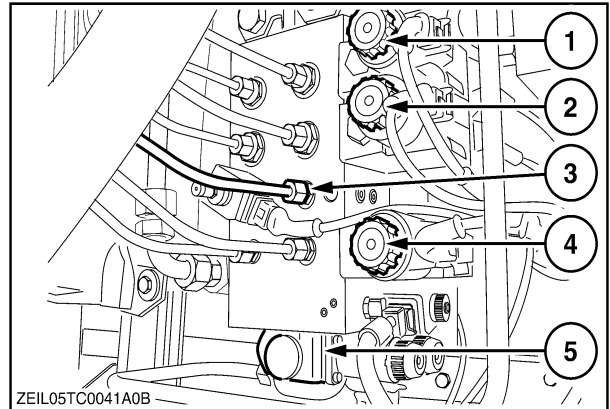

70

HYDROSTATIC SYSTEM

Hydrostatic control cable adjustment

When changing gear with the ground speed control lever in the neutral position, the combine must not move at all. If this is not the case, the cable linkage must be adjusted.

To adjust the hydrostatic control cable, proceed as follows:

1. Stop the engine.
2. Place the lever in neutral position.
3. Loosen the lock nut 10 and the nut 11 and remove eye bolt from the threaded rod.
4. Loosen the lock nut 12 and turn the eyebolt on the cable until it can be moved freely on the threaded pin of the pump adjustment lever.
5. Tighten the lock nut 12 and reinstall the nuts 10 and 11 on the threaded pin. Tighten the nuts and the lock nut sufficiently so that the eyebolt can rotate freely.

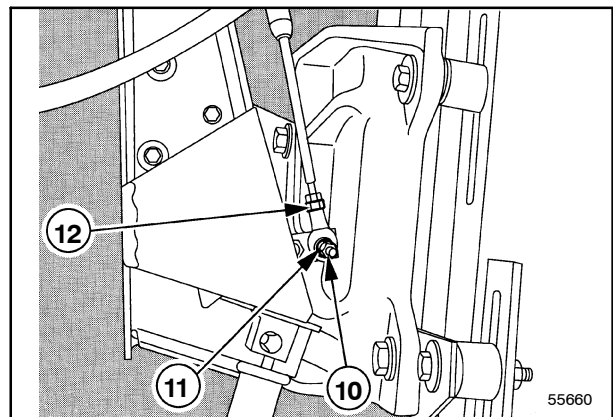

71

TRACTION GEARBOX

- TC5040 – TC5050 – TC5060

Oil level

When the combine is parked on level ground, the oil level must reach the plug 1 on the gearbox right side. Check the oil level every 50 hours.

If required, add gear oil through the filler/breather plug 2.

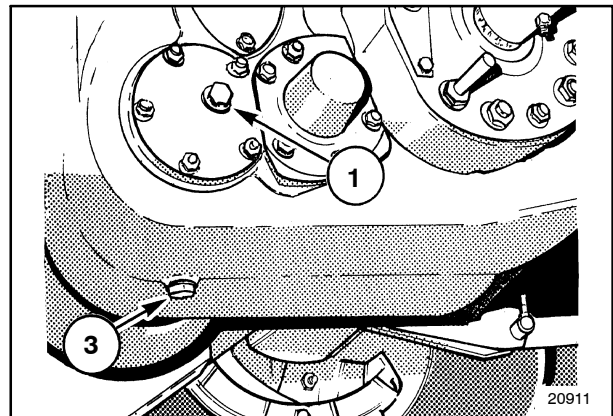

72

Oil change

- After the first 100 operating hours
- Thereafter, every 600 operating hours or annually.

Drain the oil through plug 3.

The plug 3 is fitted with a magnet which must be cleaned when changing the oil.

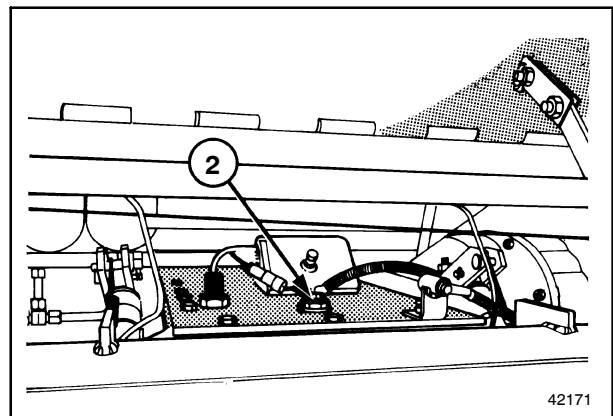

73

Oil capacity

15 litres

Oil specifications

Use AMBRA HYPOIDE 90, SAE80W90, NH520A or an oil meeting the following specifications:

- API GL5 or MIL-L-2105 D

- TC5070 - TC5080

Oil level

With the combine standing on a level surface, the oil level should reach the centre of the sight glass (1).

Oil change

The traction gearbox oil should be changed:

- After the first 100 operating hours.
- Thereafter, every 600 operating hours or annually.

To change the traction gearbox oil, proceed as follows:

1. Drain the oil through the plug (2) and catch the oil in a suitable container.
2. Reinstall the plug (2).

IMPORTANT: Clean the magnetic plug (2) before installation.

3. Clean the area around the filler/breather plug (4) and remove the filler/breather plug.
4. Fill the traction gearbox with new oil until the oil level reaches the sight glass.
5. Reinstall the filler/breather plug (4).

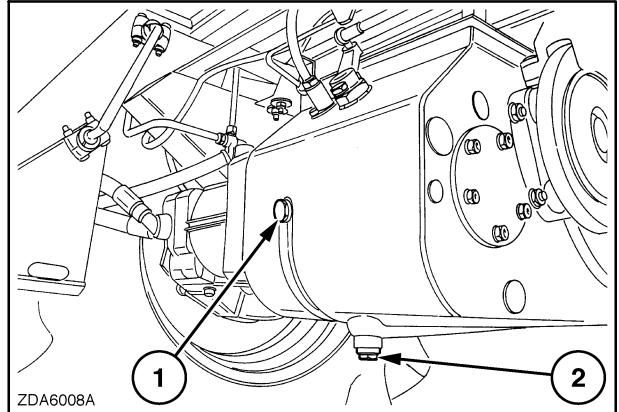

74

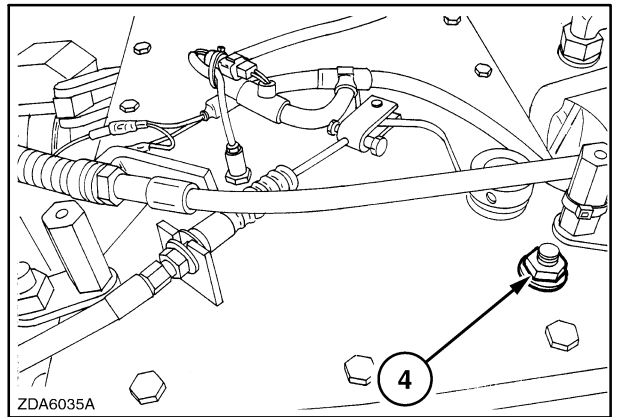

75

Oil capacity

19 litres (5 US gallons)

Oil specification

Use AMBRA HYPOIDE 90, SAE 80W90, NH520A or an oil meeting the following specification:

- API GL-5
- MIL-L-2105 D

FINAL DRIVE GEARBOXES

Oil level

Check the oil level every 50 operating hours through the plug 4 when the combine is parked on level ground.

If required, top the oil through the filler/breather plug 5.

Oil change

- After the first 100 operating hours
 - Thereafter, every 600 operating hours or annually
1. Drain the oil through the plug 6 and catch the oil in a suitable container.
 2. Reinstall the plug 6.

IMPORTANT: The plug 6 is equipped with a magnet that must be cleaned at each oil change.

3. Clean the area around the level plug 4, the filler breather plug 5 and remove them.
4. Fill the final drive gearbox with new oil.
5. Reinstall the level plug 4 and the filler/breather plug 5.

■ Oil capacity

- 5,5 litres/gearbox (standard)
- 5 litres/gearbox (for final drives with special seal)

Oil specifications

Use AMBRA HYPOIDE 90, SAE 80W90, NH520A oil or an oil meeting the following specifications:

- API GL5 or MIL-L-2105 D

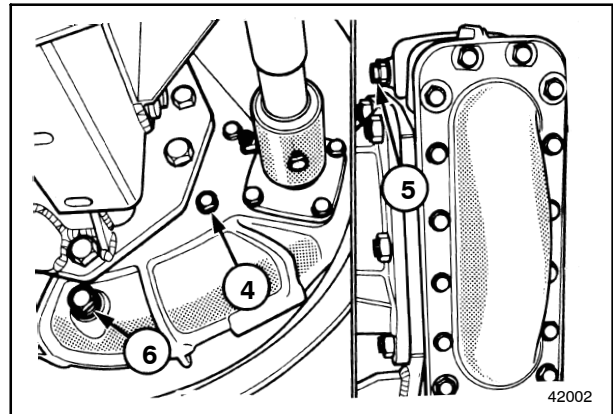

76

DELETED

CHAINS, THREADED RODS AND PIVOT POINTS

Chains

Lubricate the following chains DAILY and IMMEDIATELY AFTER WORK.

In this way the oil penetrates into the chains and provides excellent protection and lubrication. Use AMBRA HYPOIDE 90, SAE80W90, NH520A or a special (biodegradable) chain oil.

- API GL5 or MIL-L-2105 D

(Refer to the lubrication diagram for belts and chains, Section 4 – LUBRICATION AND MAINTENANCE).

- Returns auger drive
- Grain elevator drive
- Unloading auger drive

Threaded rods

Lubricate the following threaded rods every 300 operating hours:

- Drum variator
- Fan variator

Lubricate all threaded rods of the spring-loaded idlers and all other threaded rods where adjustments are carried out at least once a season.

Pivot points

It is recommended to lubricate all pivot points (including guard pivot points) which may become stiff from corrosion or dirt every 300 operating hours.

BRAKE SYSTEM

Brake fluid level

The brake fluid level (10) should be checked weekly or every 50 operating hours, according to whichever occurs first.

IMPORTANT: Never allow the level to drop below the minimum mark on the outside of the reservoir. If required, add brake fluid.

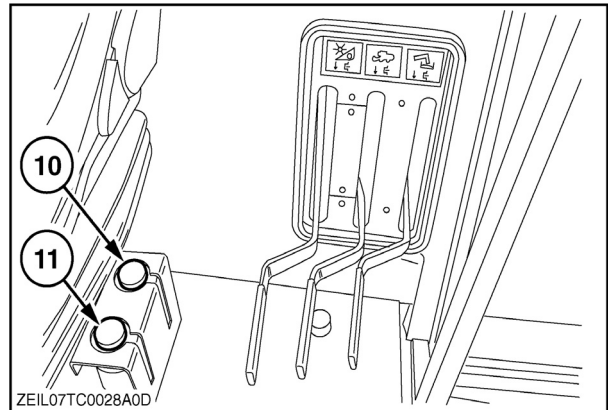

77

⚠ CAUTION ⚠

In case of leakage or malfunction of the brake system, immediately contact your local New Holland dealer

Fluid change

The brake fluid has to be changed every two years. When refilling the system, a special bleeding procedure will have to be followed.

Contact your local dealer to carry out this job.

⚠ CAUTION ⚠

- In case of leakage or malfunction of the brake system, immediately contact your New Holland dealer.
- The seals of the brake slave cylinders contain fluoroelastomers which, when used under normal conditions, are perfectly safe.

If however they are exposed to temperatures in excess of 315° C (599° F), the material will not burn, but decompose.

An extremely corrosive acid is almost impossible to remove once it has contaminated the skin.

IMPORTANT: Brake fluid has a tendency to absorb moisture and brake down over time. Therefore it should be replaced every two years. As brake fluid contains substances which, when mixed with engine or other oils, create problems for recycling the oil, do not mix oil, but collect separately.

Capacity

Reservoir: 0,25 litres (0,07 US gal.)

Entire brake system: 0,825 litres (0,21 US gal.)

Fluid specification

Use AMBRA SYNTFLUID 4, NH800A, SAE-J-1703 or a fluid meeting the following specification:

- NHTSA 116–DOT 4 or ISO 4925

Clutch fluid level (TC5040 - TC5050)

The clutch fluid level (11) should be checked weekly or every 50 operating hours, according to whichever occurs first.

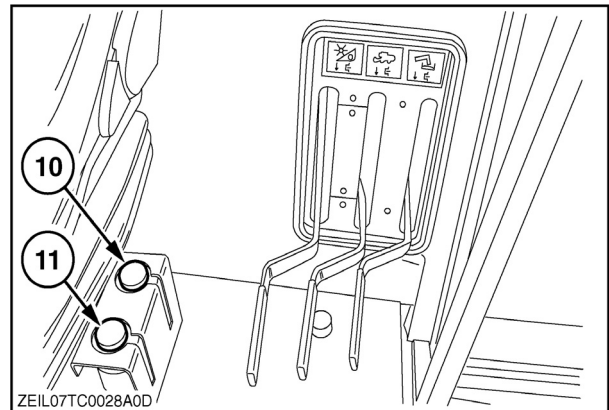

78

Fluid specification

Use AMBRA SYNTFLUID 4, NH800A, SAE-J-1703 or a fluid meeting the following specification:

- NHTSA 116–DOT 4 or ISO 4925

SECTION 4 – LUBRICATION AND MAINTENANCE

LUBRICATION SCHEDULE

ITEM	Servicing intervals	Amount unit	NEW HOLLAND brand name	NEW HOLLAND specification	Lubricant grade	International specification
Grease zerks	10 hours 50 hours 100 hours	- - -	AMBRA GR9 or AMBRA GR75MD	NH710A or NH720A		NLGI 2 NLGI 2
Traction gearbox	Check every 50 hours. Change - after the first 100 hours - every 600 hours or annually	15 litres	AMBRA HYPOIDE 90	NH520A	SAE 80W90	API GL5, MIL-L 2105D
Final drives	Check every 50 hours. Change - after the first 100 hours - every 600 hours or annually	5.5 litres	AMBRA HYPOIDE 90	NH520A	SAE 80W90	API GL5, MIL-L 2105D
Engine (sump with filter)	Check daily. Change: - every 600 hours	16 litres	AMBRA MASTER GOLD HSP	NH330H	SAE15W40	API CH-4 ACEA E3/E5
Chains	Daily					
Threaded rods	every 300 hours	-	AMBRA HYPOIDE 90	NH520A	SAE 80W90	API GL5, MIL-L 2105D
Pivot points	every 300 hours					
Brake system	Check every 50 hours. Change every two years.	0.325 litres (reservoir)	AMBRA SYNTFLUID 4	NH800A	SAE J 1703	NHTSA 116-DOT 4, ISO 4925
Clutch system	Check every 50 hours. Change every two years.	(reservoir)	AMBRA SYNTFLUID 4	NH800A	SAE J 1703	NHTSA 116-DOT 4, ISO 4925
Hydraulic system (oil + filter)	Check daily. Change: - after the first 100 hours (filter only) - every 600 hours or annually	TC5040 TC5060 20 litres	AMBRA HYDRO-SYSTEM 46	NH646 NH646BS NH646BV	HV 46	DIN 51524 Part 2 ISO VG 46
Hydraulic and hydrostatic system (oil + filter)	Check daily. Change: - after the first 100 hours (filter only) - every 600 hours or annually	TC5050 TC5070 TC5080 38 litres	AMBRA HYDRO-SYSTEM 46	NH646 NH646BS NH646BV	HV 46	DIN 51524 Part 2 ISO VG 46
Cooling system	Check daily. Change: - every two years	38 litres	50% AGRIFLU 50% WATER	NH900A	-	-

DELETED



CAUTION



Before checking and/or adjusting belts, chains or other parts described in this chapter, first of all stop the combine engine, in case no other instruction is given (for example, variator position change, etc.).. In case the engine must be started or several transmission systems need to be operated for some adjustment, make sure no bystanders are near the combine!

IMPORTANT: To guarantee an optimum operation, it is necessary to check daily the belt and chain tension. The maintenance schedule is reported at the end of this section.

DRIVE CHAIN AND BELTS (LEFT-HAND SIDE)

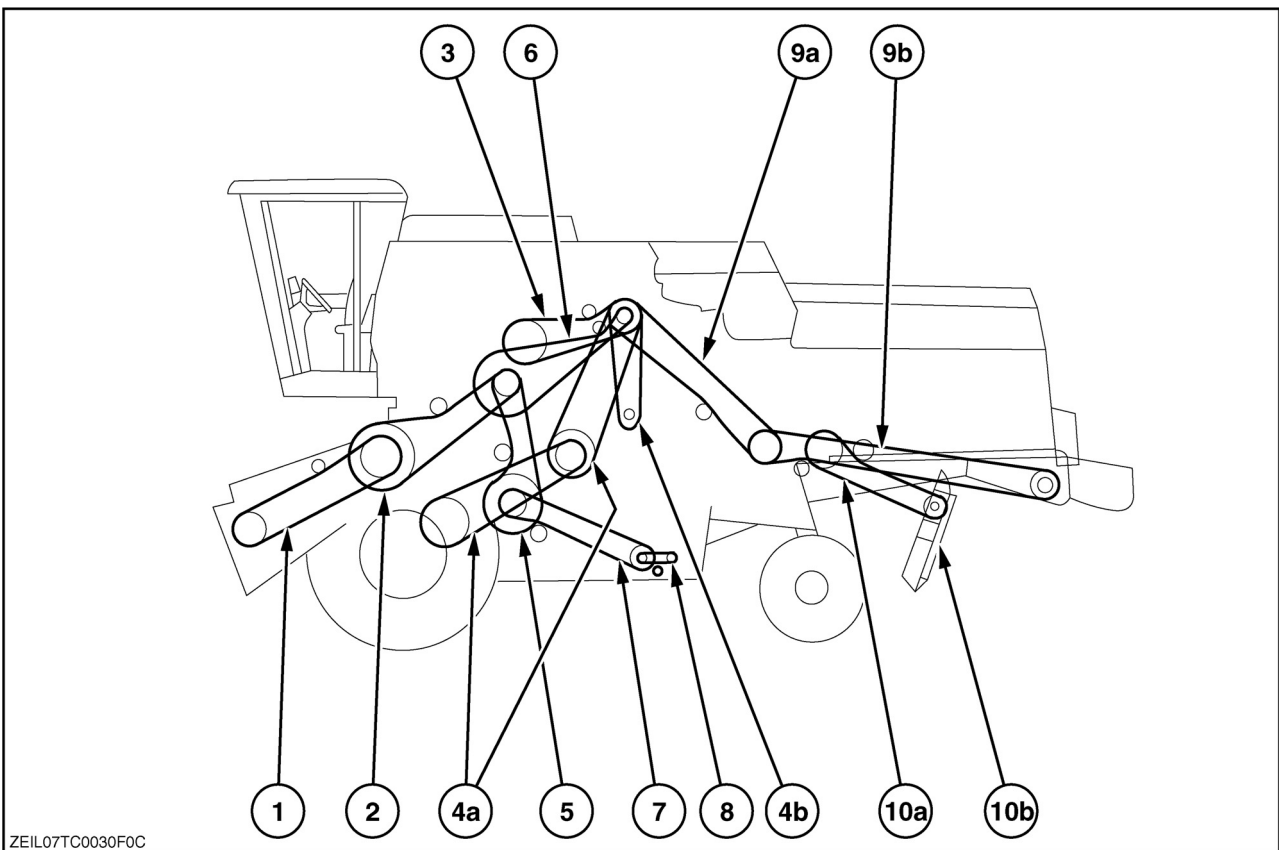

ZEIL07TC0030F0C

- | | |
|---|--|
| <ul style="list-style-type: none"> 1. Header drive belt 2. Straw elevator and header engaging drive belt 3. Unloading system engaging belt 4. a) Ground speed vari-drive belts (mechanical drive)
b) Hydrostatic pump drive belt (hydrostatic drive) 5. Cleaning shoe drive belt | <ul style="list-style-type: none"> 6. Main engaging drive belt 7. Grain cross auger and elevator drive belt 8. Grain returns cross auger and elevator drive chain 9. a) Straw chopper front drive belt (if installed)
b) Straw chopper rear drive belt (if installed) 10. a) Chaff spreader drive belt (if installed)
b) Chaff spreader discs drive belt (if installed) |
|---|--|



CAUTION



Before checking and/or adjusting belts, chains or other parts described in this chapter, first of all stop the combine engine, in case no other instruction is given (for example, variator position change, etc.).. In case the engine must be started or several transmission systems need to be operated for some adjustment, make sure no bystanders are near the combine!

IMPORTANT: To guarantee an optimum operation, it is necessary to check daily the belt and chain tension. The maintenance schedule is reported at the end of this section.

1.Header drive belt

Correct belt tension:
 thread length X = 155 mm.
 Adjust with the nuts 1.

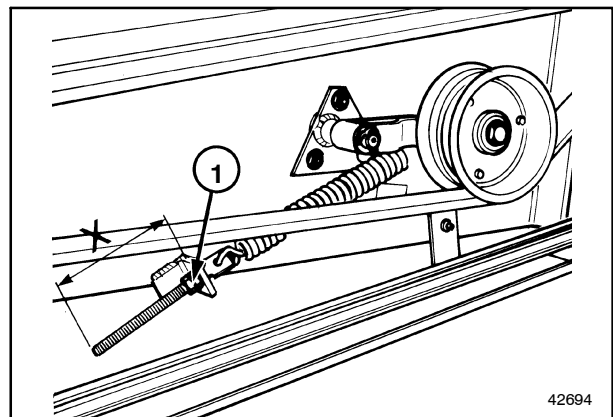

42694

80

2.Straw elevator and header engaging drive belt

• **If mechanical control**

Correct belt tension (engaged position):
 spring length 2 = indicator plate length 3.
 Adjust with the nut 4.

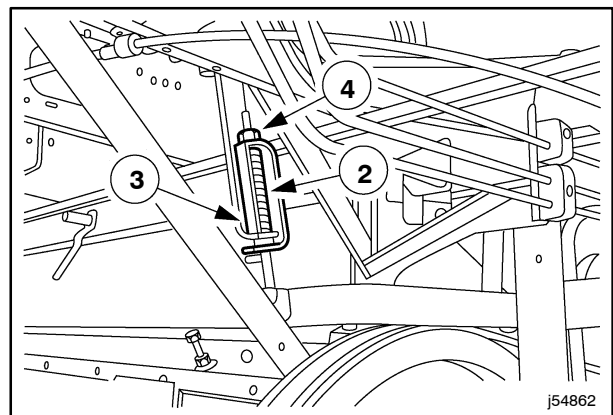

j54862

81

• **If remote control**

Correct belt tension (in engaged position)
Spring length (1) = Indicator length (2)

Adjust with the nut (3).

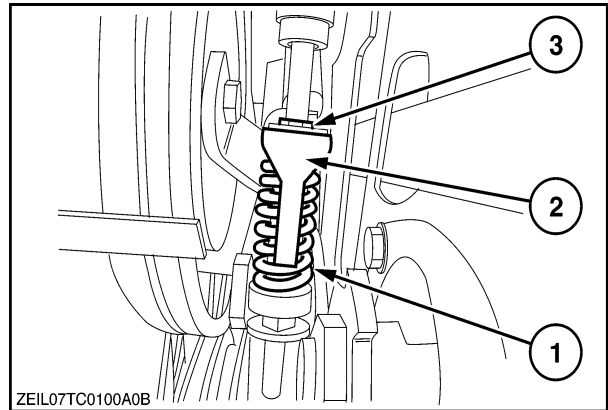

82

Proceed as follows to check and adjust the tension of the straw elevator and header engaging drive belt. To adjust, proceed as follows:



CAUTION

Make sure nobody is near the combine when starting the combine!

1. Start the engine.
2. Engage the threshing mechanism with the threshing engagement switch (4).

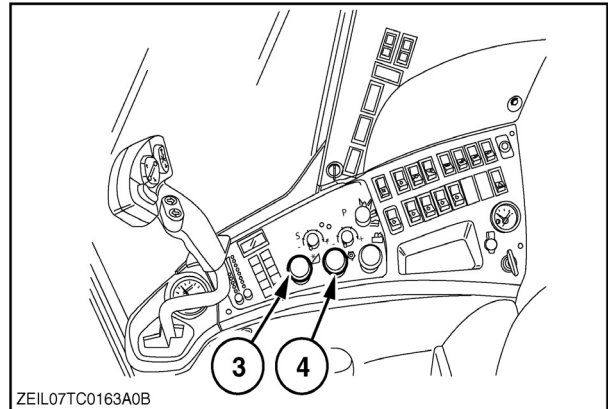

83

3. Engage the header and straw elevator drive belt by using the engagement switch (3).
4. Press on the “ESC” button for minimum four seconds. Refer to “SECTION 2 – CONTROLS, INSTRUMENTS AND OPERATION”; paragraph headed: “Display with keyboard functions”.
5. Wait until all machine components have stopped completely before touching them.
6. Check and adjust the drive belt as described above, if necessary (fig. 82).
7. After adjusting disengage the drive belts.

3. Unloading system engaging belt

- **If mechanical control**

Correct belt tension (in engaged position):
 spring length (1) = indicator plate length (2)
 Adjust with the nut (3).

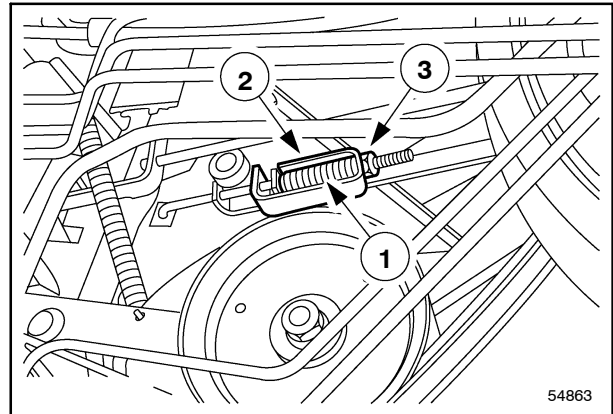

84

- **If remote control**

Correct belt tension (in engaged position):
 spring length (1) = indicator plate length (2)
 Adjust with the nut (3).

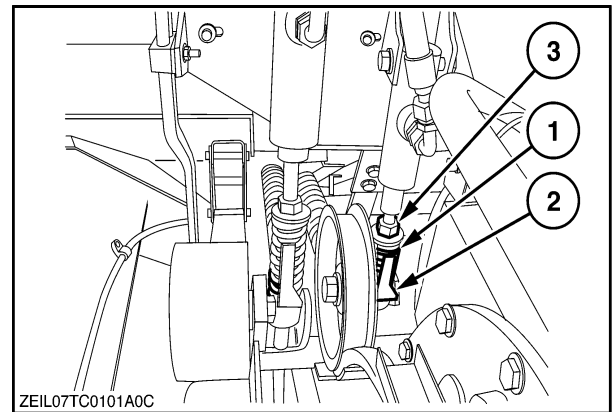

85

To adjust, proceed as follows:

1. Start the engine.
2. Open the unloading tube.
3. Engage the unloading system.



CAUTION

Make sure nobody is near the combine when starting the combine!

4. Press on the “ESC” button for minimum four seconds. Refer to “SECTION 2 – CONTROLS, INSTRUMENTS AND OPERATION”; paragraph headed: “Display with keyboard functions”.
5. Wait until all machine components have stopped completely before touching them.
6. Check and adjust the drive belt as described above, if necessary.
7. After adjusting disengage the drive belts.

4a. Ground speed vari-drive belts

Belt tension adjustment

Proceed as follows:

1. Move the traction variator to maximum 1/4 of its travel, starting from the maximum position.
2. Loosen the screw (1) and adjust with the nuts (2).
3. Tighten the screw (1) to a torque of 220 Nm.

Correct belt tension:

Upper belt deflection of 20 mm midway when applying a force between 140 and 210 N.

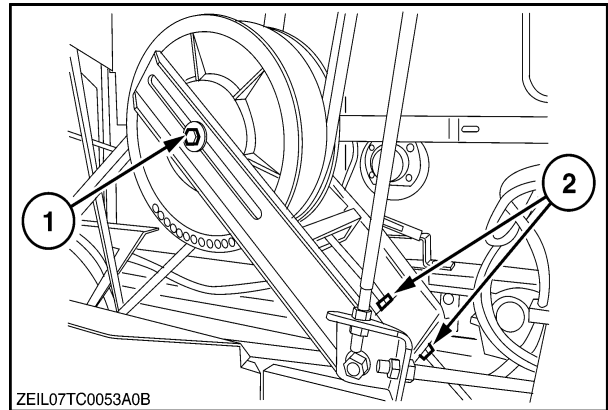

86

Traction variator adjustment

Proceed as follows:

1. First tension the belts as described above.
2. Start the engine and move the variator completely to MAXIMUM POSITION (the hydraulic cylinder rod is fully extended). Then, stop the engine again.
3. The distance X must correspond to 1 mm.

If this not the case, proceed as follows:

- a) Start the engine and move slightly the variator from maximum position. Then, stop the engine again.
- b) Loosen the nut 11 and turn slightly the adjusting block 12 and the cylinder rod in the directions here below:
 - counter-clockwise to reduce the distance X, or
 - clockwise to increase the distance X.
- c) Start the engine. First move the variator from the minimum and then to the maximum position. Then stop the engine again.

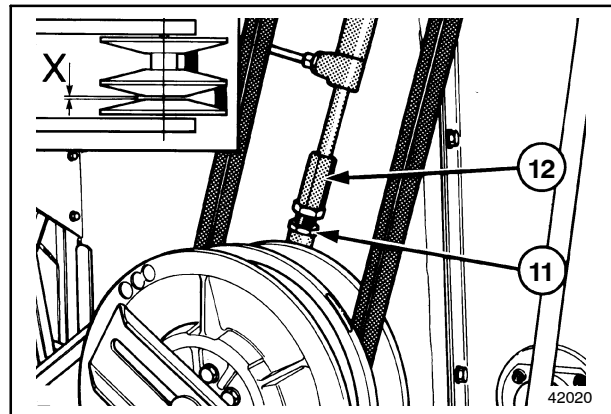

87

- d) Measure the distance X (fig. 87).
If required, repeat the above adjustment until $X = 1$ mm.
- e) Retighten the nut 11.
4. Start the engine and move the variator completely to the MINIMUM POSITION. Stop the engine.
5. Now, the distance Y must correspond to 1 mm.
If this is not the case, proceed as follows:
 - a) Start the engine and move slightly the variator from minimum position.
Stop the engine.
 - b) Loosen the nut 13 and turn slightly the adjusting block 12 and the cylinder rod in the directions here below:
 - Clockwise to increase the distance Y.
 - Counter-clockwise to decrease the distance Y.
 - c) Start the engine and move the variator firstly in maximum position and then in minimum position.
Stop the engine.
 - d) Measure the distance Y.
If required, repeat the adjustment described until $Y = 1$ mm.
 - e) Tighten the nut 13 again.

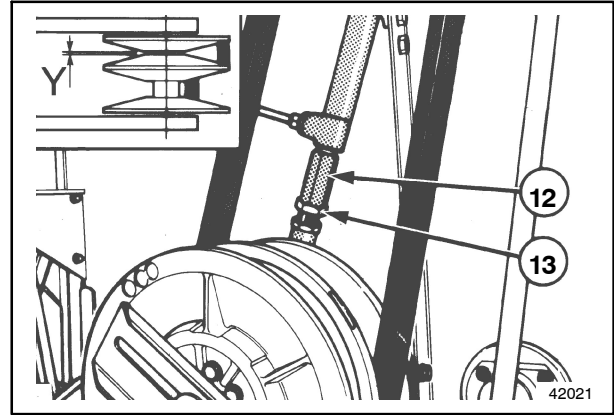

88

Variator support position

The variator must be parallel to the main frame (or the sheaves should be parallel to the drive and driven sheaves).
Adjust with the nuts (6) and (7).

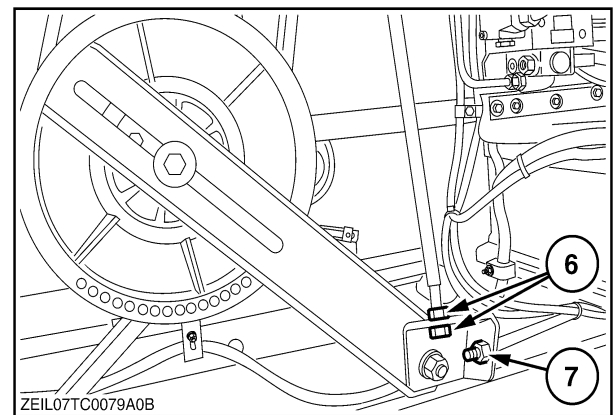

89

■ **4b. Hydrostatic pump drive belt**

The belt tension should be adjusted as follows:

1. Loosen the four screws 5 of some turns until the pump can move freely.
2. Loosen the nut 1 approximately 1 cm.
3. Tighten the nuts 2 until the distance X between the bushing 3 and the washer 4 is 1 mm.
4. Tighten the nuts 1 so that the rods, the bushing 3 and the washers 4 become one rigid part.
5. Tighten the bolts 5.

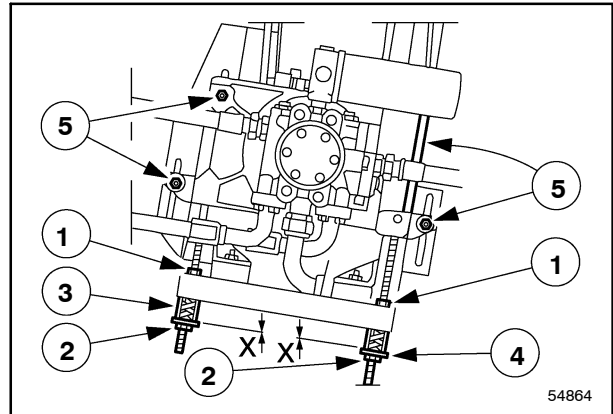

90

■ **5. Cleaning shoe drive belt**

Correct belt tension:
spring length 17 = indicator plate length 18.
Adjust with the nut 19.

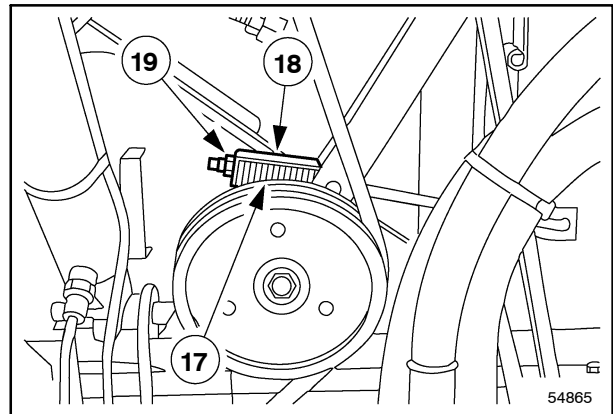

91

6. Main engaging drive belt

• **If mechanical control**

Correct belt tension (in engaged position)
 spring length (1) = indicator plate length (2)
 Adjust with the nut (3).

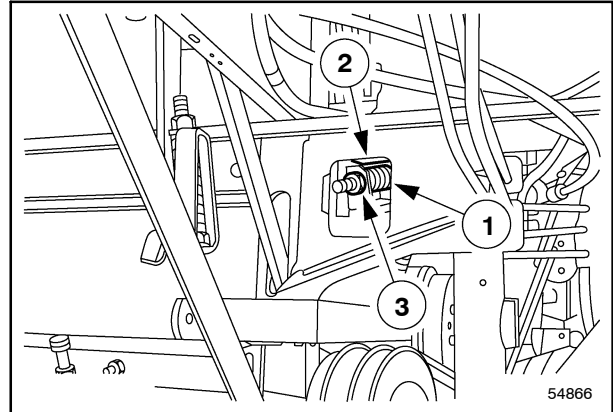

92

• **If remote control**

Correct belt tension (in engaged position):
 spring length (1) = indicator plate length (2)
 Adjust with the nut (3).

To adjust, proceed as follows:

1. Start the engine.
2. Engage the threshing system.



CAUTION

Make sure nobody is near the combine when starting the combine!

3. Press on the “ESC” button for minimum four seconds. Refer to “SECTION 2 – CONTROLS, INSTRUMENTS AND OPERATION”; paragraph headed: “Display with keyboard functions”.
4. Wait until all machine components have stopped completely before touching them.
5. Check and adjust the drive belt as described above, if necessary.
6. After adjusting disengage the drive belts.

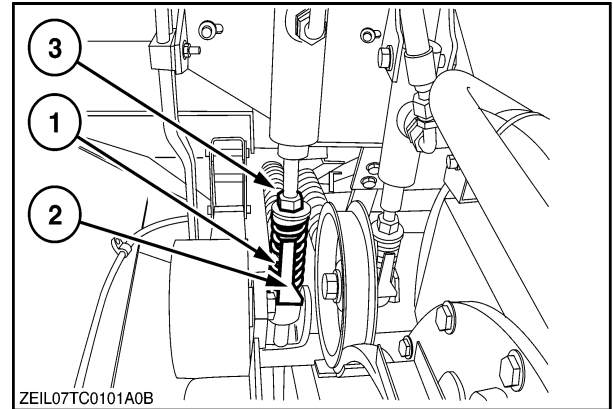

93

7. Grain cross auger and elevator drive belt

Correct belt tension:
spring length 1 = indicator plate length 2.
Adjust with the nut 3.

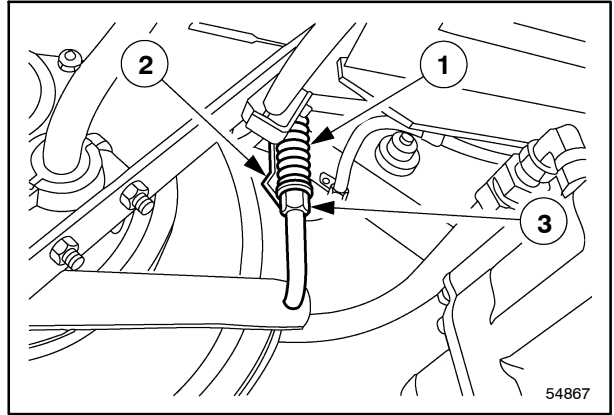

Bottom view 94

8. Grain returns cross auger and elevator drive chain

The chain is adjusted by means of the idler 4.
Loosen the nut 5 and move the idler 4.
Retighten the nut 5.

The chain tension is correctly adjusted when it is just possible to move a link laterally across a sprocket by hand.

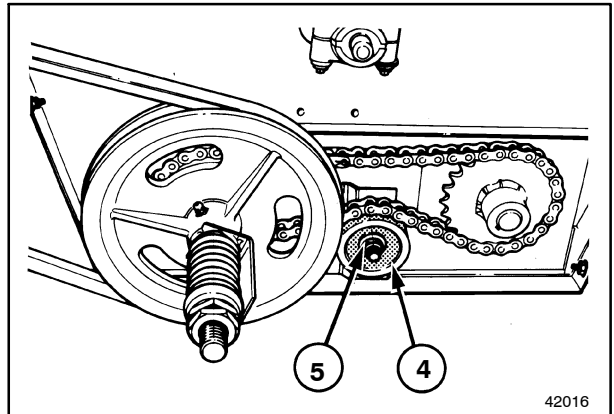

95

9a. Straw chopper front drive belt (if installed)

A spring-loaded idler.

Correct belt tension:
spring length 4 = indicator plate length 5.
Adjust with the nut 6.

9b. Straw chopper rear drive belt (if installed)

Correct belt tension:
spring length 1 = indicator plate length 2.
Adjust through the nuts and lock nuts 3.

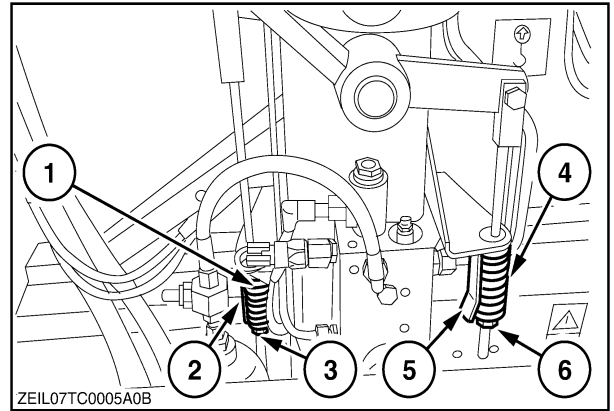

96

10a. Chaff spreader drive belt (if installed)

The belt tension is correct:
spring length (1) = indicator length (2).
Adjust with the nut (3).

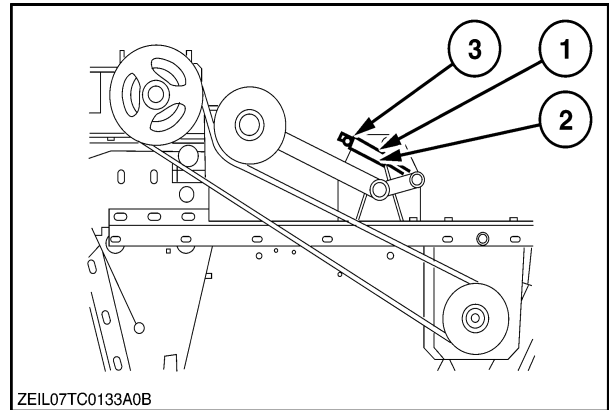

97

10b. Chaff spreader discs drive belt (if installed)

The belt tension is correct:
spring length (1) = indicator length (2).
Adjust with the nut (3).

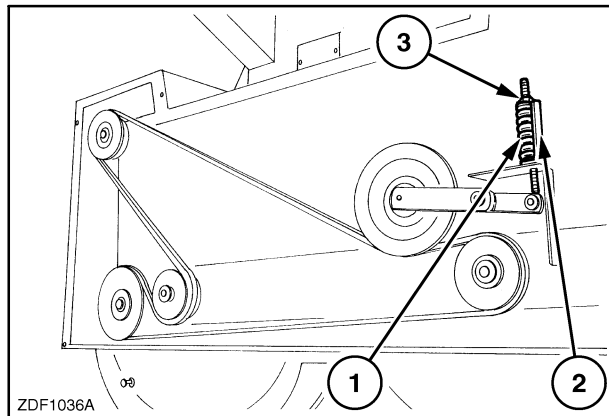

98

DRIVE CHAIN AND BELTS (RIGHT-HAND SIDE)

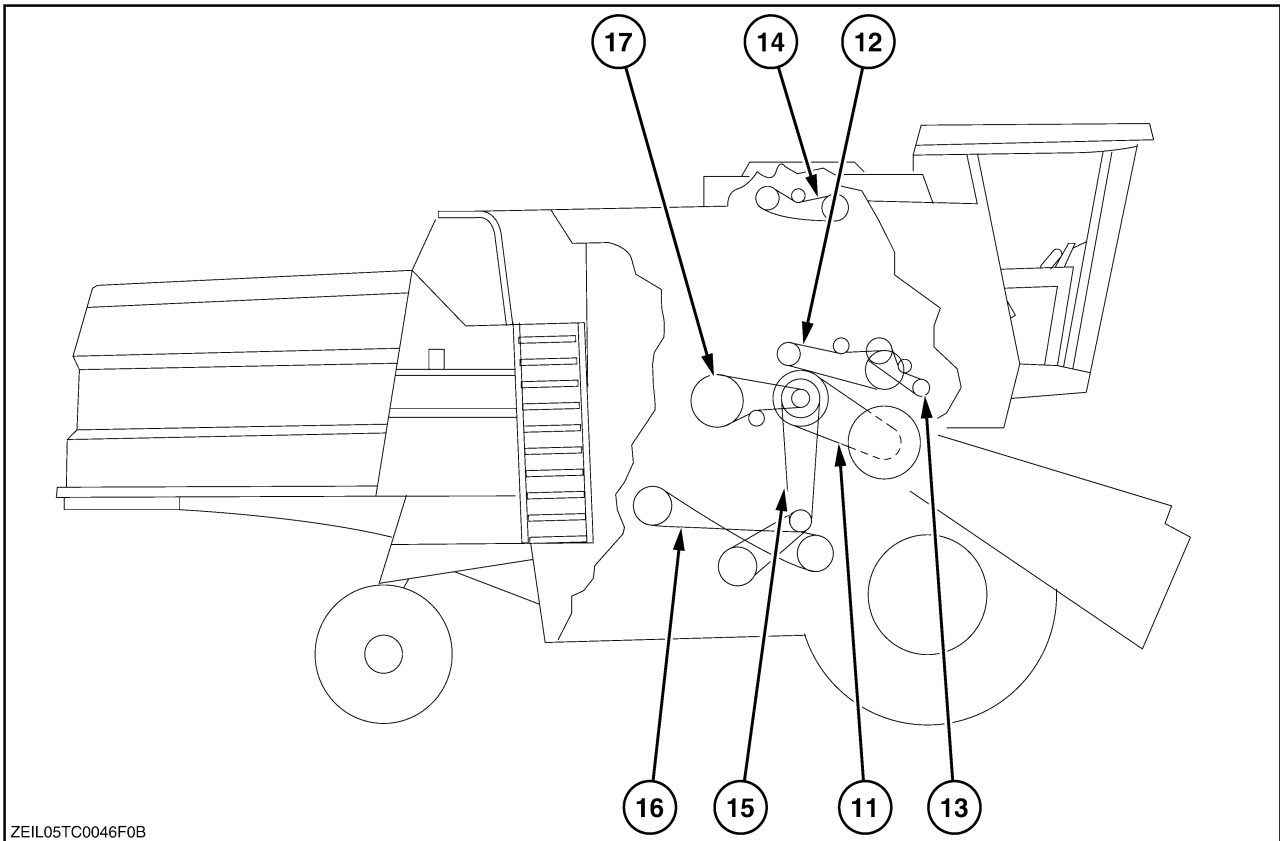

- 11. Drum variator belt
- 12. Grain tank bottom auger drive chain
- 13. Returns top auger drive chain
- 14. Grain tank filling auger drive chain
- 15. Cleaning fan variator drive belt
- 16. Straw walker drive belt
- 17. Rotary separator drive belt (if installed)

11. Drum variator belt

Correct belt tension:
 spring length 1 = indicator plate length 2.
 Adjust with the nut 3.

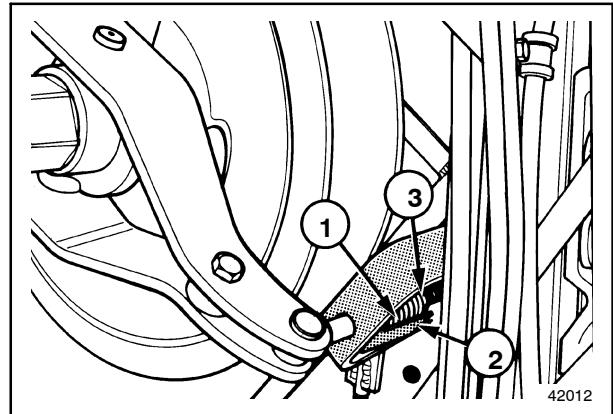

100

Check and adjustment of variator

Proceed as follows:

1. First tension the variator drive belt as described above.
2. Start the engine, engage the threshing mechanism and adjust the drum variator up to the MINIMUM. LEVEL. Then, stop the engine.
3. Check the distance "X" between the drive sheaves, which must be minimum 1 mm (or the belt depth "W" on the drive sheaves, which must be 78 mm).

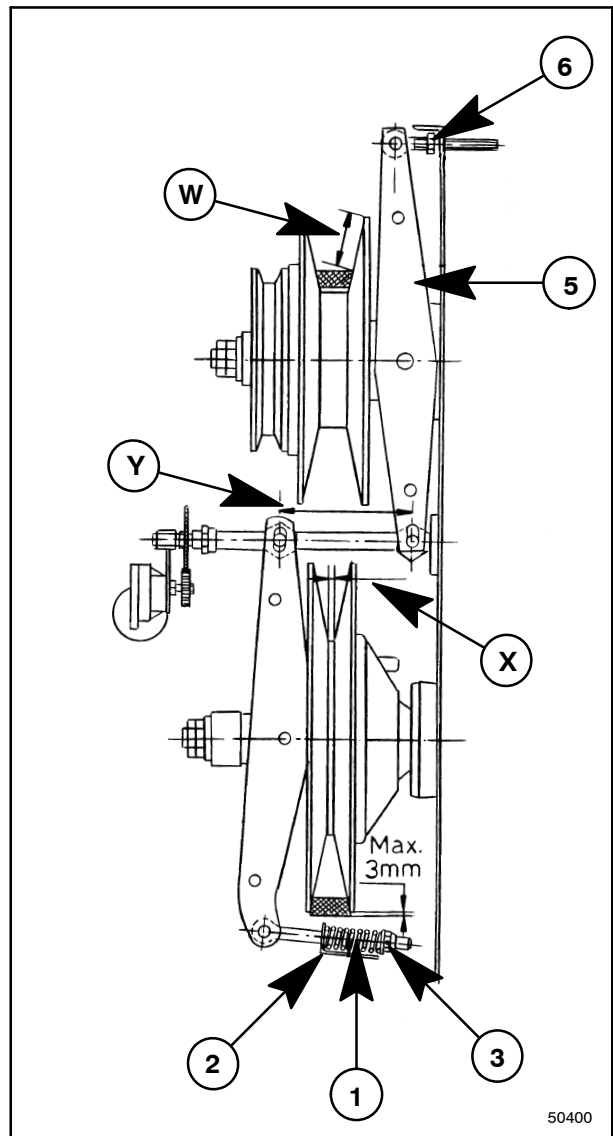

101

If this is not the case, proceed as follows:

- a) First check the distances “Y” and “Z”.
The distance “Y” must be 179 mm.
The distance “Z” must be 67 mm.
- b) The distance “Y” must be adjusted moving the arms 4 and 5 on the threaded rods.
The distance “Z” can be adjusted by the nut 6.
- c) If required (when the distance “X” is lower than 1 mm or if the belt depth “T” does not correspond) it is possible to adjust by the nut 6.
- d) Start the engine, engage the threshing mechanism adjust the drum variator up to the MAX. LEVEL. Then, stop the engine.
- e) Check the distance “X” between the drive sheaves, which must be minimum 1 mm (or the belt depth “V” on the driven sheaves must be 78 mm). If not, adjust with the nut 7.

NOTE: In case of a stretched belt, the belt can be allowed to extend 3mm beyond the edge of the drive sheaves.

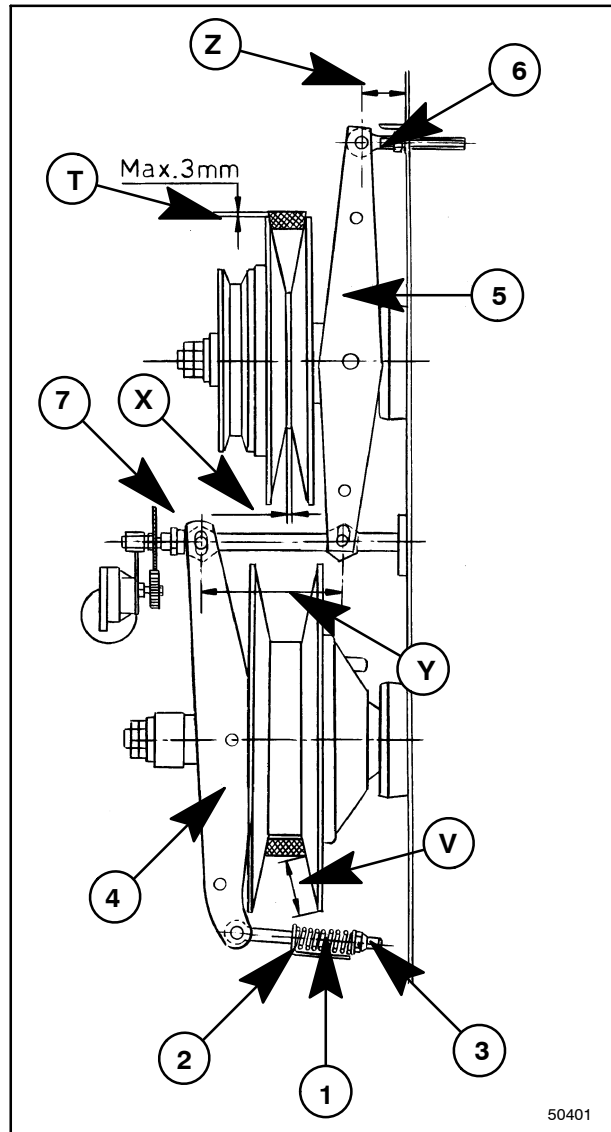

102

12. Grain tank bottom auger drive chain

Chain tension to be adjusted with the idler 8.
Loosen the nut 10 and move the idler 8.
Retighten the nut 10.

The chain tension is adjusted correctly when it is just possible to move a link laterally across a sprocket by hand.

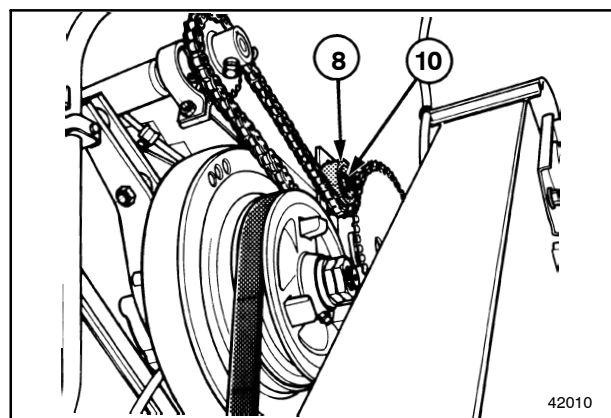

103

13. Returns top auger drive chain

Chain tension to be adjusted with the idler 11.
Loosen the nut 12 and move the idler 11.
Retighten the nut 12.

The chain tension is adjusted correctly when it is just possible to move a link laterally across a sprocket by hand.

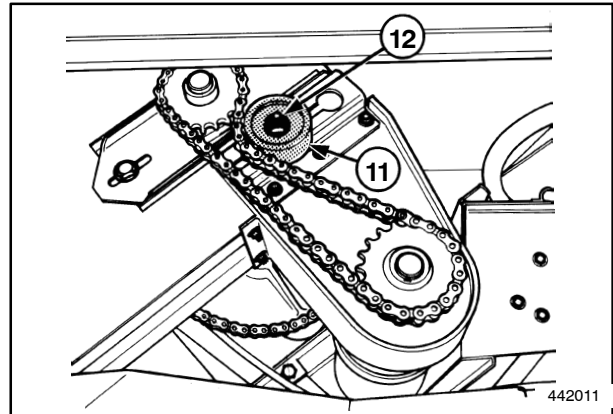

104

14. Grain tank filling auger drive chain

The chain tension can be adjusted with the idler 13.
Loosen the nut 14 and move the idler 13.
Retighten the nut 14.

The chain tension is adjusted correctly when it is just possible to move a link laterally across a sprocket by hand.



Adjust this chain from inside the grain tank.

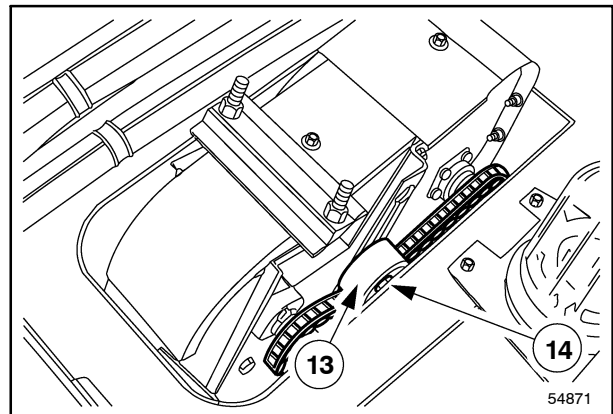

105

15. Cleaning fan variator drive belt

Proceed as follows:

1. Move the variator to the middle position.
Stop the engine.
2. Loosen the screw 16 and adjust with the nut 17.
3. Retighten the screw 16.

Correct belt tension:
Upper belt deflection of 14 mm halfway the front part when applying a force of 30 N.

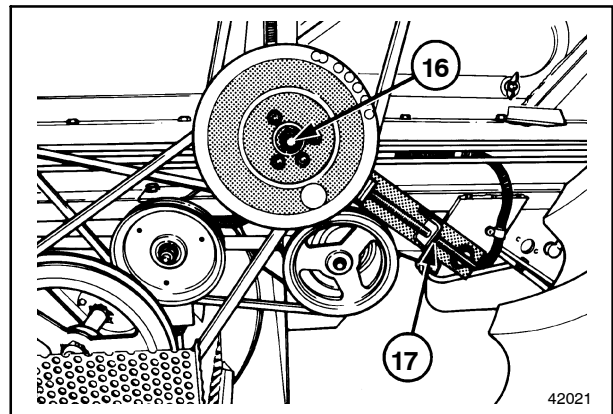

106

Fan variator adjustment

Figure 107: manually operated

Figure 108: electrically operated

Proceed as follows:

1. First tension the variator drive belts as described above.
2. Start the engine and move the variator completely to MAXIMUM POSITION. Then, stop the engine again.
3. Check the distance X. This distance must be minimum 1 mm.
If not, adjust with the nut 18.
4. Start the engine and move the variator completely to MINIMUM POSITION. Then stop the engine again.
5. Check the distance Y which must be minimum 1 mm.
If not, adjust with the nut 19.

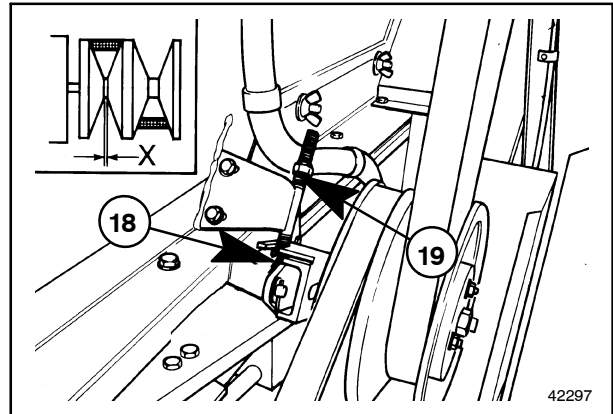

107

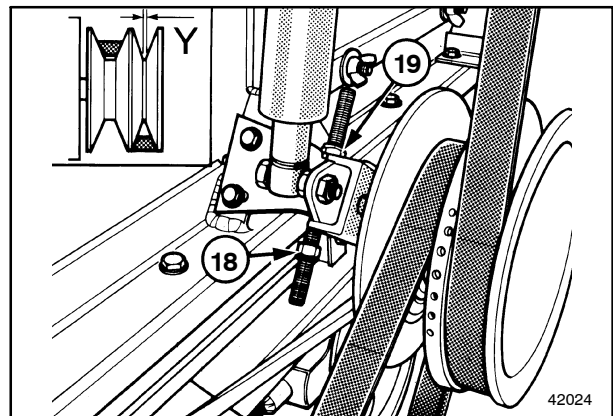

108

16. Straw walker drive belt

Belt tension to be adjusted with the idler 20.
Loosen the nut 22 and adjust with the nut 23.
Retighten the nut 22.

The belt tension is correct when the belt can be deflected 15mm when applying a force of 1.88kg halfway between the pulleys at F. When a new belt is installed, a force of 2.32 kg is applied to deflect the belt 15 mm.

The belt is allowed to touch in the crossing point by vibration.

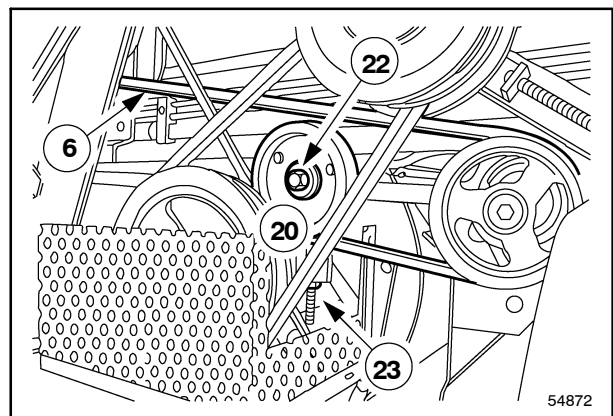

109

17. Rotary separator drive belt (if installed)

Correct belt tension:
spring length 18 = indicator plate length 19
Adjust with the nut 20

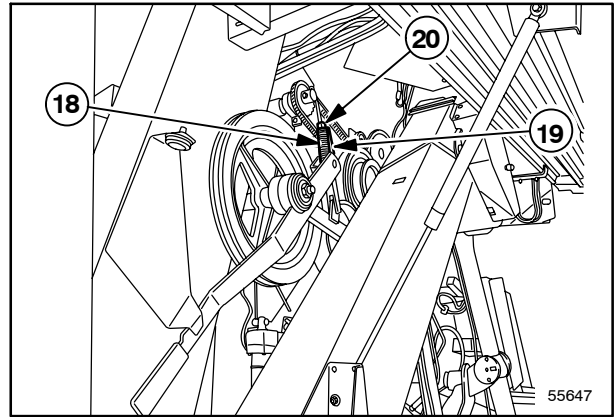

DRIVE BELTS - ENGINE COMPARTMENT

TC5040 – TC5050 – TC5060

- 18. Rotary dust screen drive belt
- 20. Rotary dust screen intermediate shaft drive belt
- 21. Engine cooling fan drive belt
- 23. Alternator and water pump drive belt
- 24. Air conditioning compressor drive belt (if installed)

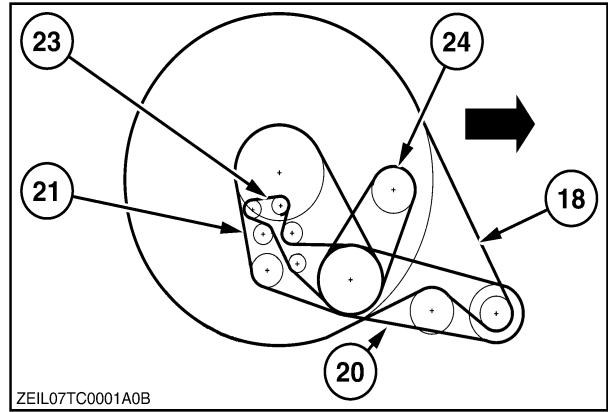

111

TC5070 – TC5080

- 18. Rotary dust screen drive belt
- 19. Alternator, water pump and air conditioning compressor drive belt
- 20. Rotary dust screen intermediate shaft drive belt
- 21. Engine cooling fan drive belt
- 22. Hydraulic pump drive belt

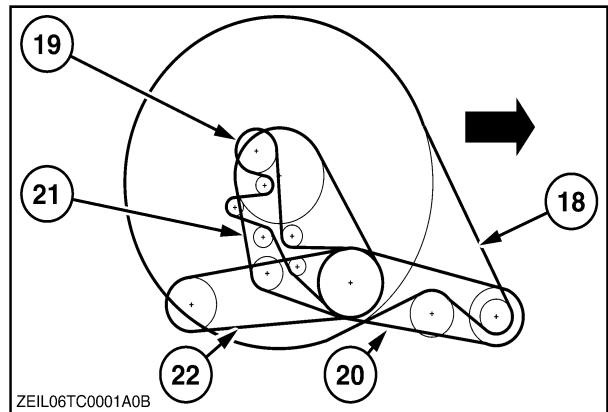

112

18. Rotary dust screen drive belt

The belt tensioned with the spring loaded idler (1) and does not need any adjustment.

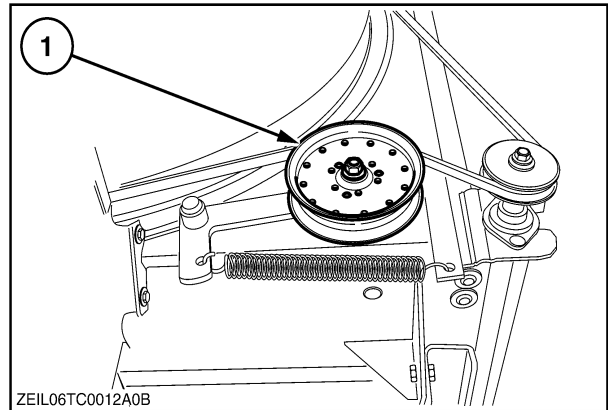

113

19. Alternator, water pump and air conditioning compressor drive belt (TC5070 - TC5080)

No adjustment needed as the system is self-adjusting.

20. Rotary dust screen intermediate shaft drive belt

The belt tension is correct:
Applying a force of 23 N (5.17 lbf) on the midpoint of the belt between the two pulleys, should deflect the belt 3 mm (1/8").

To adjust the belt tension, proceed as follows:

1. Loosen the two bolts (1).
2. Tighten the bolt (2) to obtain the correct belt tension. The bearing housing moves in slotted holes.
3. Tighten the two bolts (1).

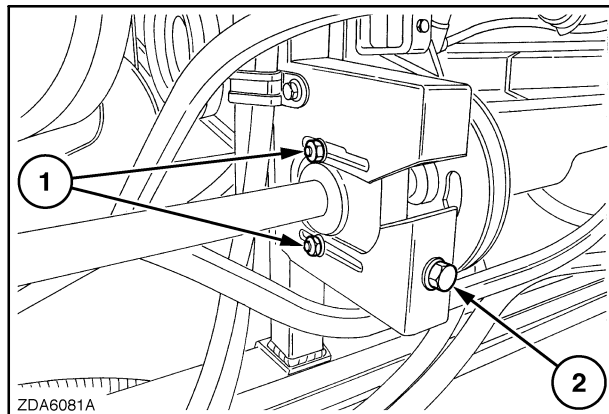

114

21. Engine cooling fan drive belt

Correct belt tension:
 spring length 1 = indicator plate length 2
 Adjust with the nut 3

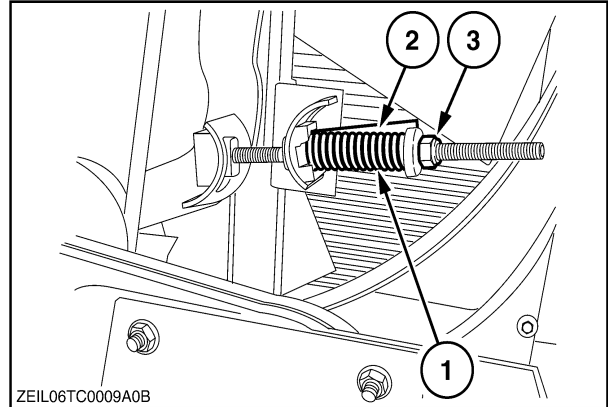

115

22. Hydraulic pump drive belt (TC5070 - TC5080)

Applying a force of 30 N at the midpoint of the belt should deflect the belt 7.6 mm.

Loosen the three nuts (1) and adjust with the nuts (2) and (3).

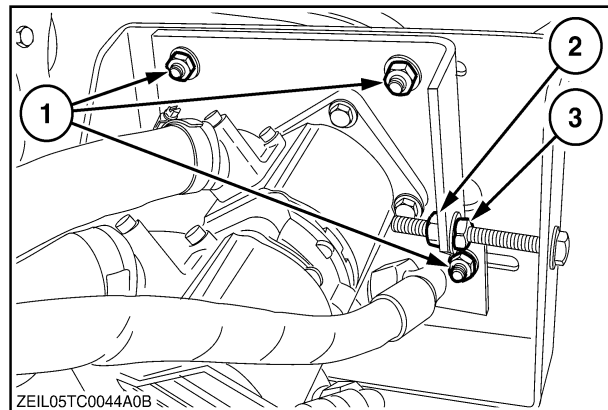

116

23. Alternator and water pump drive belt (TC5040 - TC5050 - TC5060)

No adjustment needed as the system is self-adjusting.

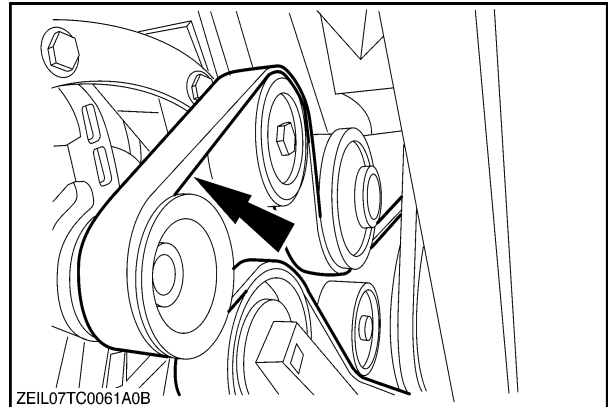

117

24. Air conditioning compressor drive belt (If installed) (TC5040 - TC5050 - TC5060)

The belt tension is correct :
 Applying a force between 10.4 and 11.1 N on the midpoint of the belt between the two pulleys, should deflect the belt 3.78 mm.

Adjust with the bolt (1).

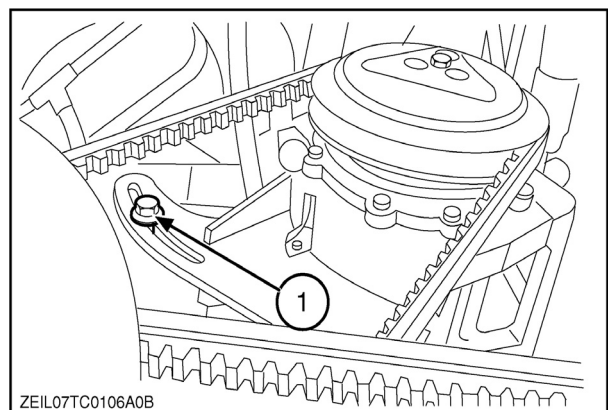

118

STRAW ELEVATOR

Chain tension

To adjust the chain tension, tighten the spring 6 with the nut 7 on both sides of the straw elevator and then loosen it to the length of the indicator plate 8.

When the chain has stretched so far that the mounting supports are at the end of the slots, the chain has to be shortened by removing half a link from each chain.

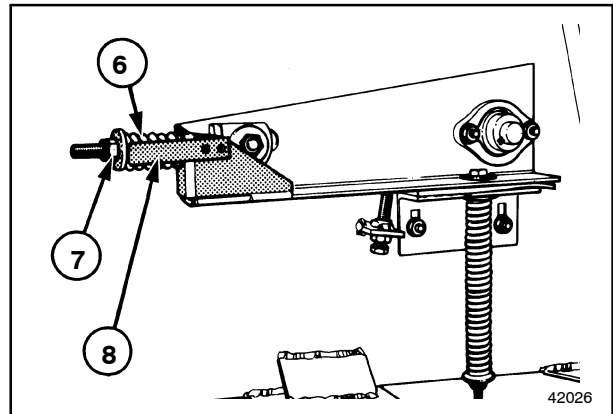

119

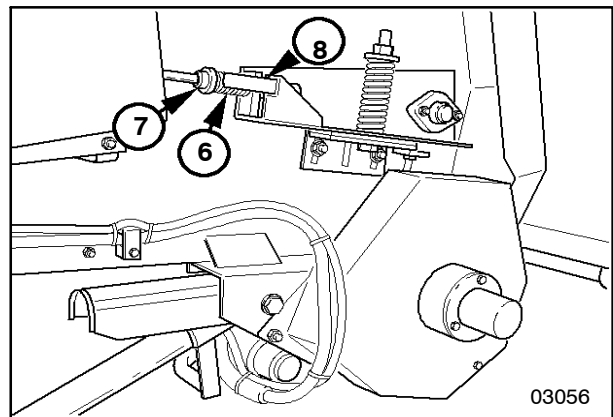

120

Straw elevator slip clutch

The audible slip clutch 10 is factory-set at 600 Nm for average conditions and must not be further tensioned.

To adjust the clutch to the correct setting, tighten the nut 12 (left hand thread) completely until it touches the collar on the shaft.

The tightening torque should be between 313 and 373 Nm.

Tighten the nut 12 with the nut 13 (right-hand thread) with a torque between 313 and 373Nm.

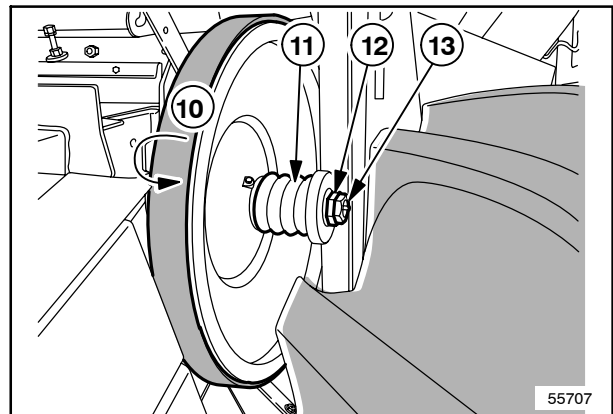

121

ELEVATOR CHAINS

Grain elevator

The tension of the grain elevator can be adjusted at the top of the elevator.



Adjust this chain from inside the grain tank.

Proceed as follows:

1. Loosen the tension of the chain 14 by loosening idler 16.
2. Loosen the screw 17 and tighten the nuts 18 on both sides of the elevator head **evenly**.

Correct chain tension:

The chain tension is correct when it is just possible to move the link laterally across a sprocket by hand.

3. Tighten the screw and tension the drive chain as described in paragraph headed "Drive chains and belts – right-hand side", subheading "14. Grain tank filling auger drive chain".

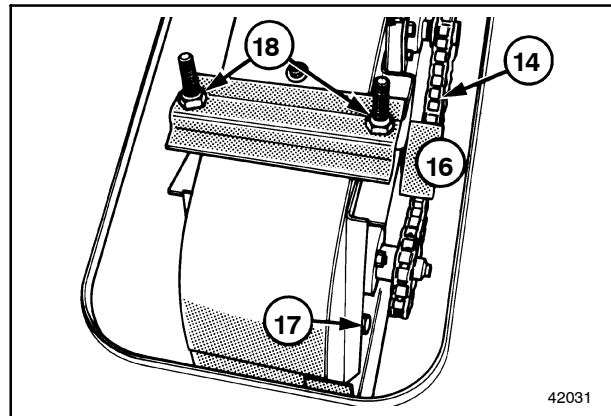

122

Returns elevator

The tension of the returns elevator chain can be adjusted at the top of the elevator.

Proceed as follows:

1. Loosen the idler 20 to release the chain tension 19.
2. Loosen the screw 21 and tighten the nuts 22 on both sides of the elevator head **evenly**.

Correct chain tension:

The chain tension is correct when it is just possible to move the link laterally across a sprocket by hand

3. Tighten the screw and tension the drive chain as described in paragraph headed "Drive chains and belts – right-hand side", subheading "13. Returns top auger drive chain"

Elevator slip clutch

The grain and returns elevator drives are protected by an audible slip clutch 23.

To adjust proceed as follows:

- **TC5040 - TC5050**

1. Compress the spring (26) with the nut (1).
2. Release the nut (1) five turns.
3. Tighten the lock nut.

- **TC5060 - TC5070 - TC5080**

1. Loosen the lock nut from nut (1).
2. Adjust the nut (1) until the spring (26) has become a length of 93 mm.
3. Tighten the lock nut.

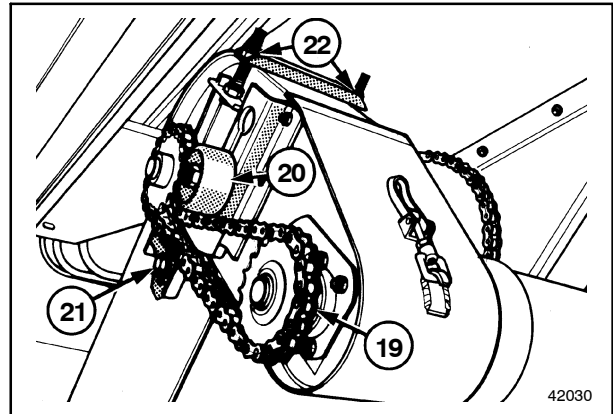

123

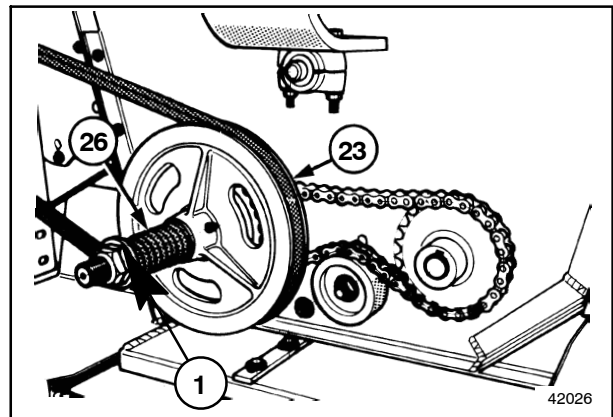

124

SELF-LEVELLING SYSTEM CALIBRATION

When the warning light (9) for **self-levelling** starts glowing, then:

- Either the side slope inclination exceeds the capability of the self-levelling system, meaning that grain losses are likely, or
- That the self-levelling system is incorrectly calibrated.
(the control box is positioned incorrectly)

To check and correct the calibration, proceed as follows:

1. Position the machine on a level ground.
2. Stop the engine and make sure that all mechanisms are disengaged. Then, turn the ignition key in contact position.
3. Slightly loosen both screws of the control box on the inside of the instrument panel and move the control box until the middle red warning light remains glowing (do not remove the connector).

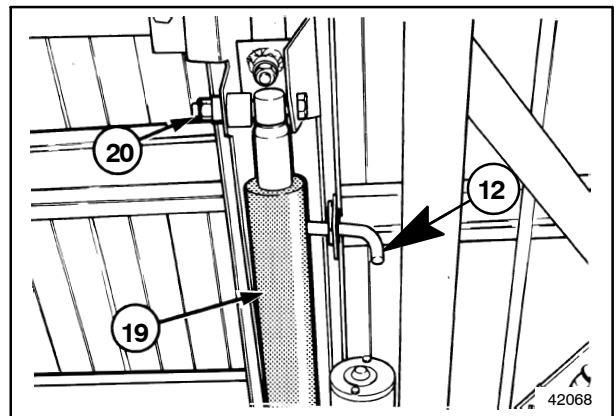

125

4. Engage the automatic levelling override switch (2) placed at the rear of the combine) until the upper sieve is in the horizontal position (four holes where pin (12) fits, should be aligned).
5. Loosen the levelling actuator (19) at (20) and let it hanging free.
6. With the ignition key still in the contact position and with stopped engine, engage the threshing mechanism once or repeatedly until the levelling system audible signal and the warning light (9) remain extinguished.
7. Disengage the threshing mechanism and remove the ignition key.
8. Rotate the actuator rod in or out until the holes are in line at (20).
9. Reinstall the actuator (19) at (20).

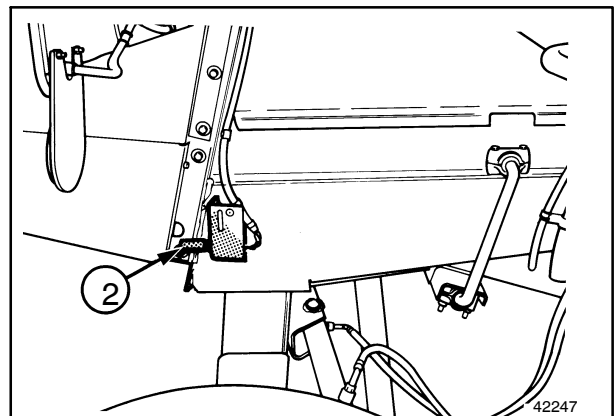

126

SELF-LEVELLING SYSTEM BLOCKAGE

When the automatic self-levelling alarm led on the alarm control module (see page 2-14) starts blinking at one-second intervals and the audible signal sounds, the self-levelling system maybe seized or the power supply is interrupted.

In this case, proceed as follows:

1. Stop the combine.
2. Keep the threshing mechanism engaged.
3. Press the self-levelling rocker reset switch (24).

The automatic levelling moves in the most opposite position and then goes back to the horizontal position.

The self-levelling warning light will blink during the reset mode.

4. The warning light must switch off and the buzzer must stop.

If not, even after a second reset trial, stop the combine completely. Check if the automatic levelling system is still blocked or contact your local dealer.

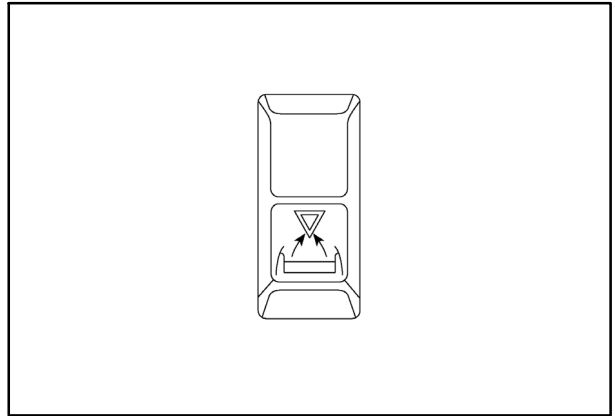

127

BRAKES



WARNING



The braking system of your combine was carefully designed and balanced to provide optimum braking performance.

It is important to ensure that only brake linings meeting NEW HOLLAND specifications for the combine are used. The use of brake linings having incorrect friction properties may result in a reduction of braking efficiency. Only use genuine NEW HOLLAND replacement parts.

Brakes belong to the components that are subject to homologation in many countries, and must therefore not be altered.



CAUTION



In case of leakage or malfunction of the brake system, contact immediately your local dealer.

FOOT BRAKES

TC5040 – TC5050 – TC5060

To bleed or to replace the brake linings, contact your local dealer.

It is necessary to check the brake linings:

- when the brake warning light illuminates
- after 600 operating hours in normal conditions
- after 300 operating hours in heavy brake conditions (for example “spin-turns” in maize fields, when driving on hilly grounds, etc.).

Check regularly the foot brake adjustment as described below:

1. Press the brake pedal down with a force of 22 daN.
2. Measure the brake cylinder displacement at 4.
3. The foot brake is correctly adjusted when the brake cylinder displacement is between 5.8 and 6.2 mm.
Adjust with the nuts 7.

Combines stored for several days or weeks may require a “bedding-in” procedure before the machines are put into operation in order to ensure a consistent brake performance.

Foot brake “bedding-in” procedure

1. Drive the machine at minimum throttle in first or in second gear.
2. Apply the brakes without declutching or bringing the hydrostatic control lever to neutral position (i.e. brake against the engine power).
Press down the brake pedals as hard as you can (approximately 80 kg force) for about 5 seconds, then release the brakes.
3. Repeat this procedure twice or three times.

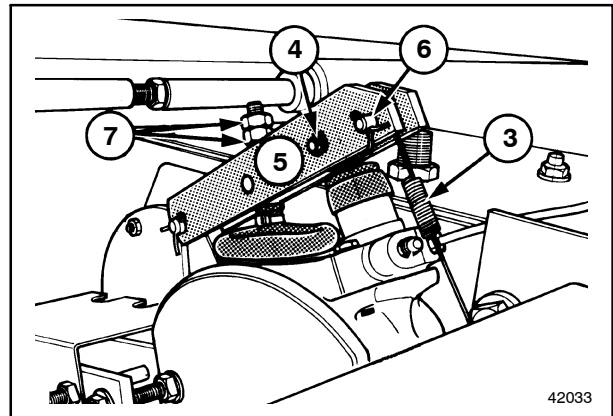

PARKING BRAKE

- TC5040 – TC5050 – TC5060

- On differential shaft (if fitted)

When properly adjusted, the parking brake lever should be halfway through its stroke when fully applied.

In the lowest position of the handbrake lever, the cable should be adjusted in such a way that a distance “X” of 0.5 to 1 mm exists between the levers 11 and the pins 12. The adjustment can be carried out at clamping bolt 13.

When the end of the adjustment is reached, loosen the nuts 14 and shorten the cable at clamping bolt 13, then finally adjust the nuts 14.

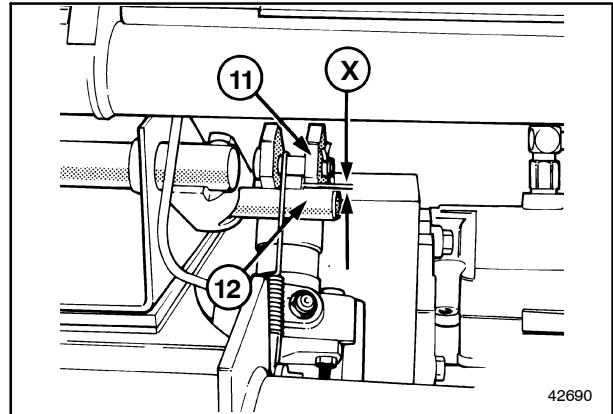

129

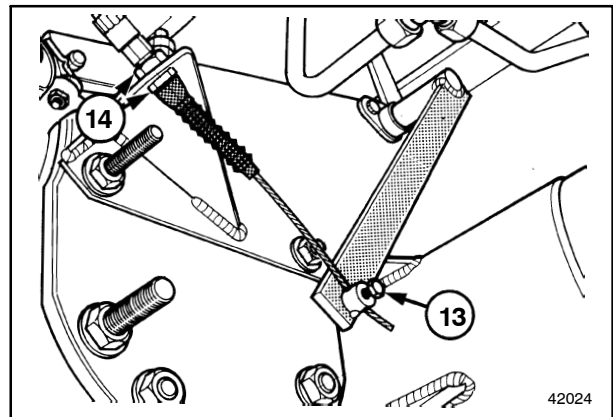

130

- On transmission shaft (if fitted)

When properly adjusted, the parking brake lever should be halfway through its stroke when fully applied. A fine adjustment can be made with the nuts 16. When the end of the adjustment is reached, loosen the nuts 16 and shorten the cable 17 at clamping bolt 18, then finally adjust the nut 16.

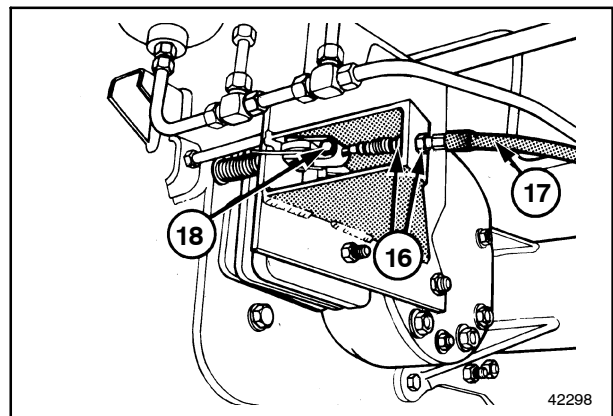

131

• TC5070 – TC5080

1. Disengage the parking brake in the cab.
(= bottom position)
2. Loosen the two nuts (1) and the two bolts (2).
3. Check that dimension “X” is between 180 and 184 mm (7-1/6” and 7-1/4”), make sure that the cable (3) is straight (fig. 133).

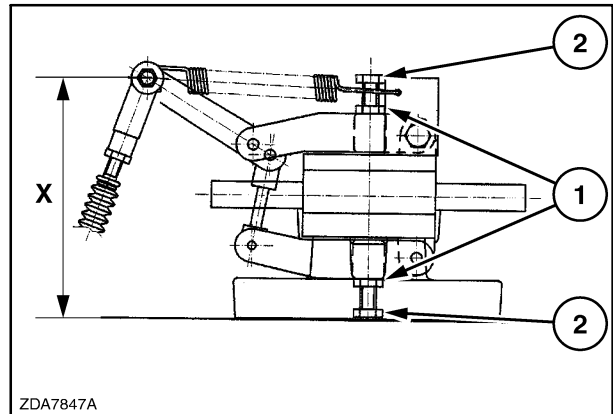

132

4. If not, adjust with the nuts (4) and (5).
After adjusting, tighten the nuts (4) and (5).

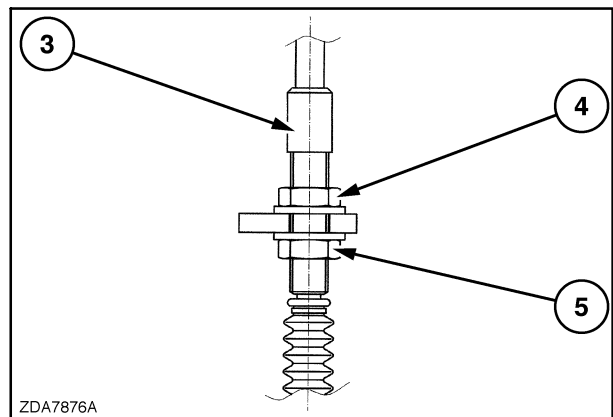

133

5. Simultaneously tighten the two bolts (2) by hand until they touch the brake blocks. Engage and disengage the parking brake in the cab a few times.
6. Check the tightness of the two bolts (2). If possible, tighten them simultaneously by hand. Turn them an extra quarter of a turn with a spanner.
7. Engage and disengage the parking brake in the cab a few times.
8. Loosen the two bolts (2) and tighten them simultaneously by hand, after loosen the two bolts (2) with 1/6 of a turn.
9. Tighten the locknuts (1). Ensure that the two bolts (2) not turning with the nuts (1).

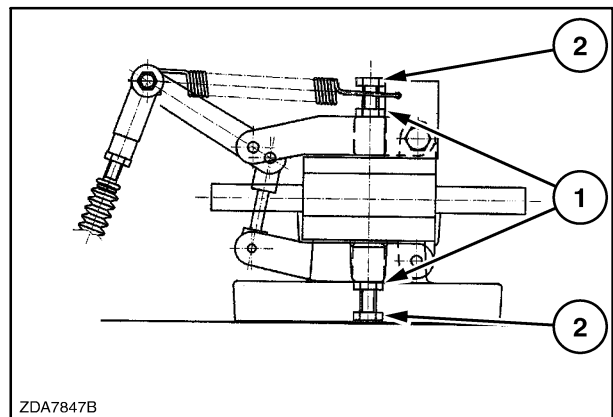

134

TRACTION CLUTCH

■ • TC5040– TC5060

Usually, the clutch adjustment is not required.

However, should an adjustment be necessary, proceed as follows:

1. Remove the pin 19 and loosen the lock nut 14.
2. Push in the cylinder pushrod 5 to take away internal clearance and adjust the yoke 20 until the pin 19 can be inserted without interference.
3. Additional screw up the yoke 20 one turn.

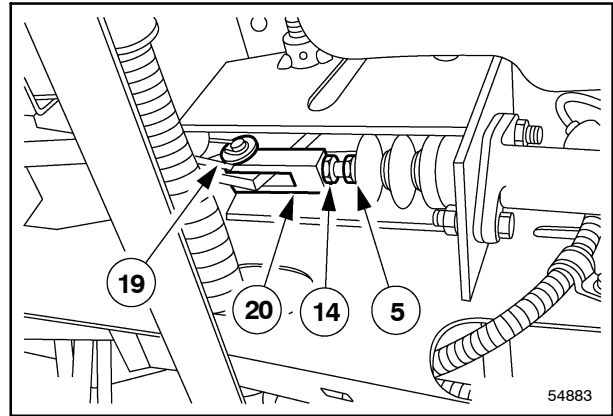

Under the operator's platform

135

4. Install the pin 19 and tighten the lock nut 14.
5. Remove the pin 21 from the lever 22.
6. Push the plunger rod 23 in the cylinder.
7. Adjust the yoke 26 until the distance 24 between the hole in the lever 22 and the hole in the yoke 26 measures 27.5 mm.
8. Reinstall the bolt 21.

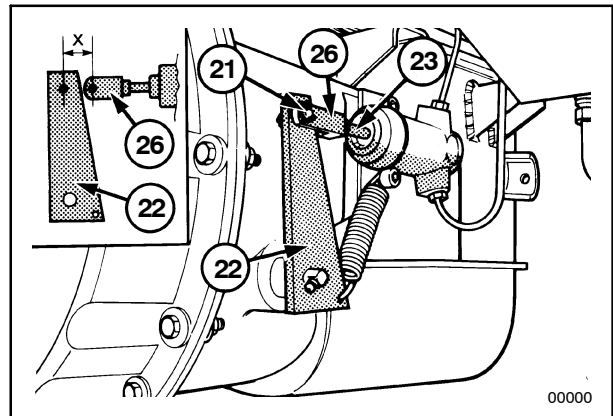

136

STEERING AXLE

TOE-IN ADJUSTMENT

The steering wheels should have the correct amount of toe-in, otherwise premature tyre wear may occur. The distance between the steering wheels must be smaller at the front than at the rear (facing the direction of travel).

To check and adjust the toe-in, proceed as follows:

1. Apply the parking brake and support the steering axle so that the steering wheels are clear of the ground.



CAUTION

Use suitable jack stands, securely positioned underneath the rear of the machine, before adjusting the steering axle. Steering ball joints, wheel spindles, tie rods and steering hydraulic components should be checked every 50 hours of operation.

2. Set the steering wheels in straight ahead position.
3. Mark spots at 273 mm from the centre of the inner front side of the wheel rims at the wheel centre and measure the distance 2.
4. Turn the steering wheels 180° forward or rearward until the marks are at the centre-of-wheel height and measure the distance 3.
The distance 3 must be 8 to 12 mm greater than the distance 2.
5. To adjust the toe-in, loosen the jam nuts 5, remove the steering ball 6 out of the steering arm and turn the steering ball in or out the rod 4, evenly on both sides. After adjustment, tighten the slotted nut of the steering balls 6 and the jam nuts 5 (see further in this section).

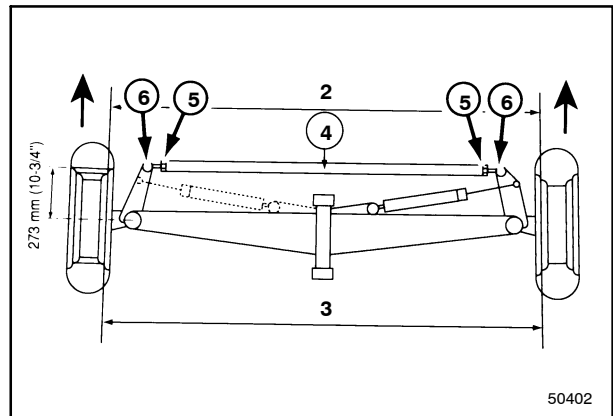

FIXED STEERING AXLE

Adjustment

Adjust the toe-in as described in the previous paragraph.

Steering wheel stops

The steering wheel stops are factory-set and should normally require further adjustment.

If, for any reason, the stops require adjustment, proceed as follows:

1. Turn the bolt 5 completely in.
2. Rotate the steering wheel to the extreme left or right-hand position so that the steering cylinder is at the end of its stroke.
3. Retract the steering cylinder by 2 mm.
4. Turn the screw 5 against the rear axle and tighten the lock nut.
5. Proceed in the same way on the opposite side.

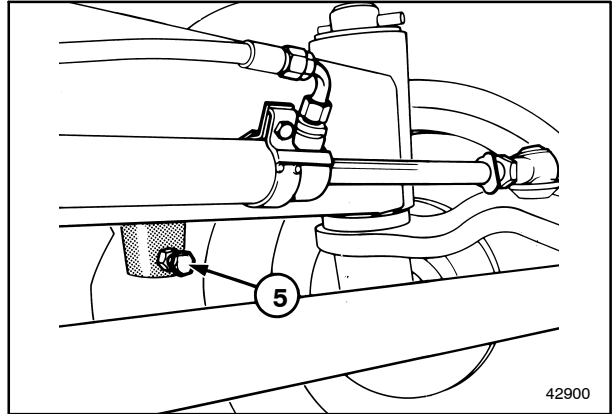

138

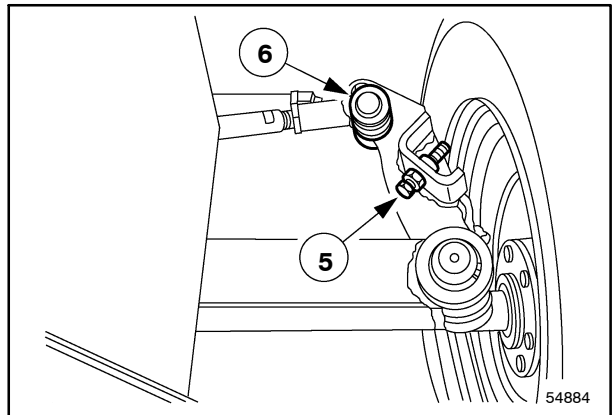

139

Steering ball joints

Check the steering ball joints of the steering axle every 50 operating hours for correct nut torque or possible play.

If, for any reason, the steering ball joints where disassembled, the nut torque should be as mentioned in fig. 140 and 141.

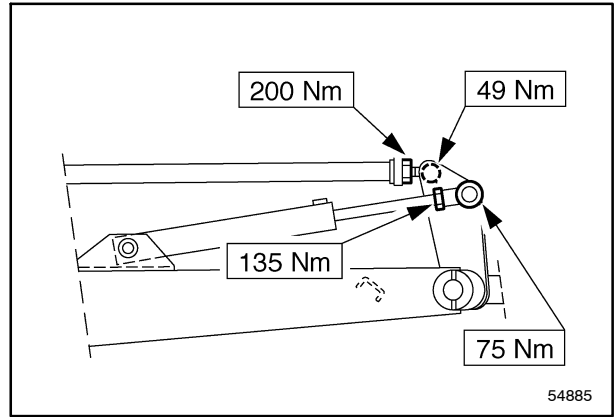

140

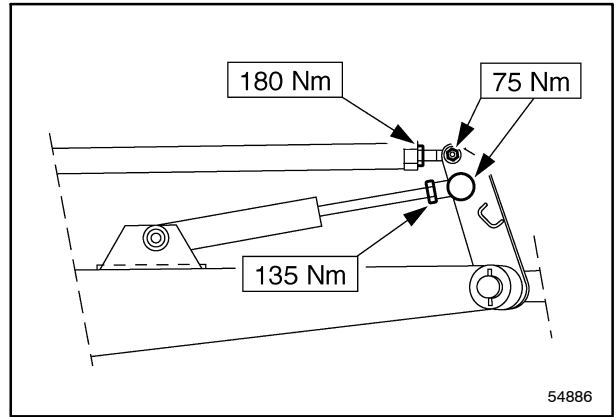

141

**ADJUSTABLE STEERING AXLE
(IF INSTALLED)**

The adjustable steering axle can be set in three positions:

- narrow position

NOTE: in Germany, this position is envisaged by law when driving on public roads.

- medium position
- wide position

Adjustment



CAUTION

Before adjusting the steering axle, it is necessary to support the combine adequately by means of stands to be placed under the combine back.

Proceed as follows:

1. Engage the parking brake and support the steering axle on the left-hand side.
2. Loosen the screw 7 and hammer it towards the middle of the axle until the key 6 releases.
3. Remove the screw from the tie rod 4 and the screws 8 from the steering wheel.
4. Set the steering axle on the left-hand side at the necessary and/or required width.
5. Fit the screws 8 again.
6. Beat with a hammer on the screw 7 to remove it until the key 6 seats and tighten the screw 7 with a torque of 140 Nm.
7. Tighten the screws 8 with a torque of 294 Nm.
8. Support the steering axle on the right-hand side and adjust, as outlined above.
9. Install the steering cylinder support 10 in the correct position.
10. Place the screws in the tie rod.

Adjust the toe-in following the procedure described in the previous paragraph.

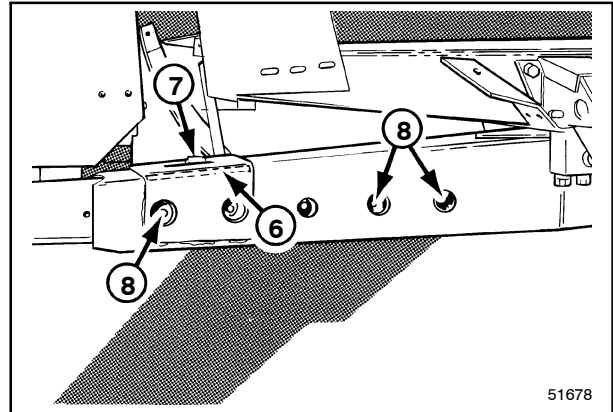

51678

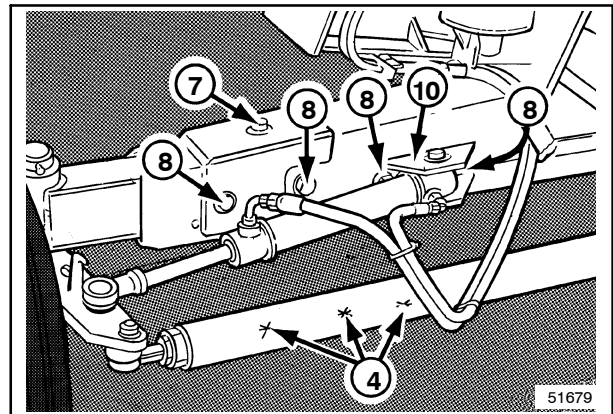

51679

Steering wheel stops

The steering wheel stops are factory-set and should normally not require further adjustment.

Nevertheless, in case the stops are to be adjusted, proceed as follows:

1. Turn the screw 5 completely in.
2. Rotate the steering wheel to the extreme left or right-hand position, until the steering cylinder is at the end of its stroke.
3. Retract the steering cylinder by 2 mm.
4. Turn the screw 5 against the support and tighten the safety nut.
5. Repeat the same procedure on the opposite side, too.

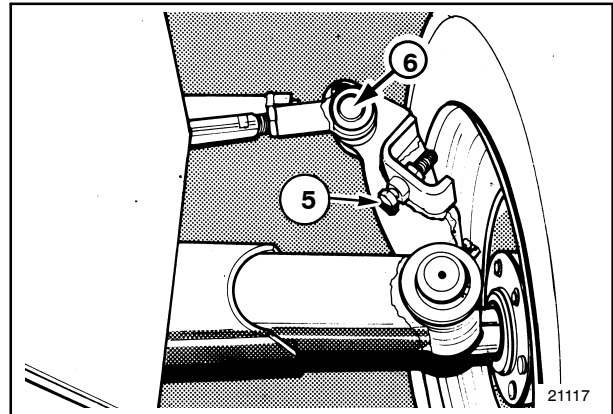

144

Steering axle ball joint

Every 50 operating hours, check that the tightening torque or the possible steering axle ball joint clearance are correct.

Should for any reason the steering axle ball joints were disassembled, keep to the tightening torque indicated in figure 145.

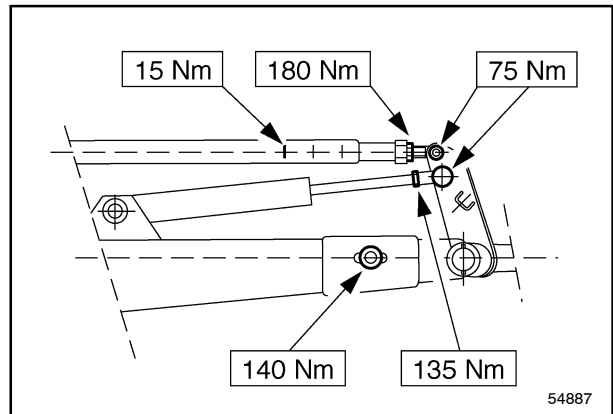

145

ELECTRICAL SYSTEM

Fuses and relays

IMPORTANT:

- When replacing a fuse, make sure the new fuse has the **same** amperage as the fuse being replaced.
- When replacing a relay, make sure the new relay has the same structure (visible on the relay housing) of the replaced relay. Always use genuine parts.

1. Fuse printed circuit: located at the right-hand side above the right-hand module

Remove the cover (12) to have access to the fuse or relay.

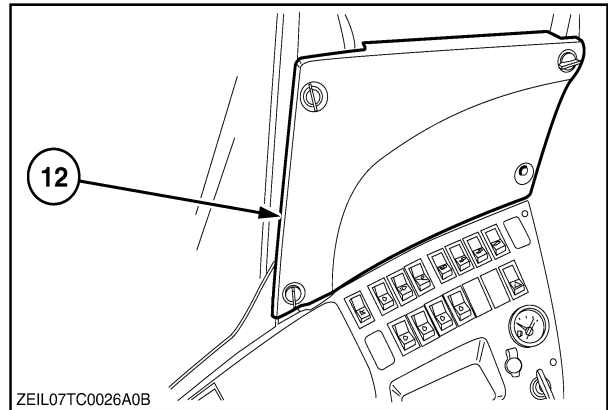

146

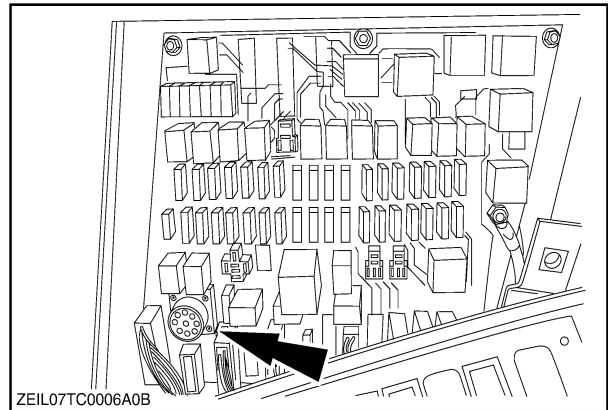

147

A decal on the inside of panel (12) shows the symbols for the function of each fuse or relay (see also next page)

SECTION 4 – LUBRICATION AND MAINTENANCE

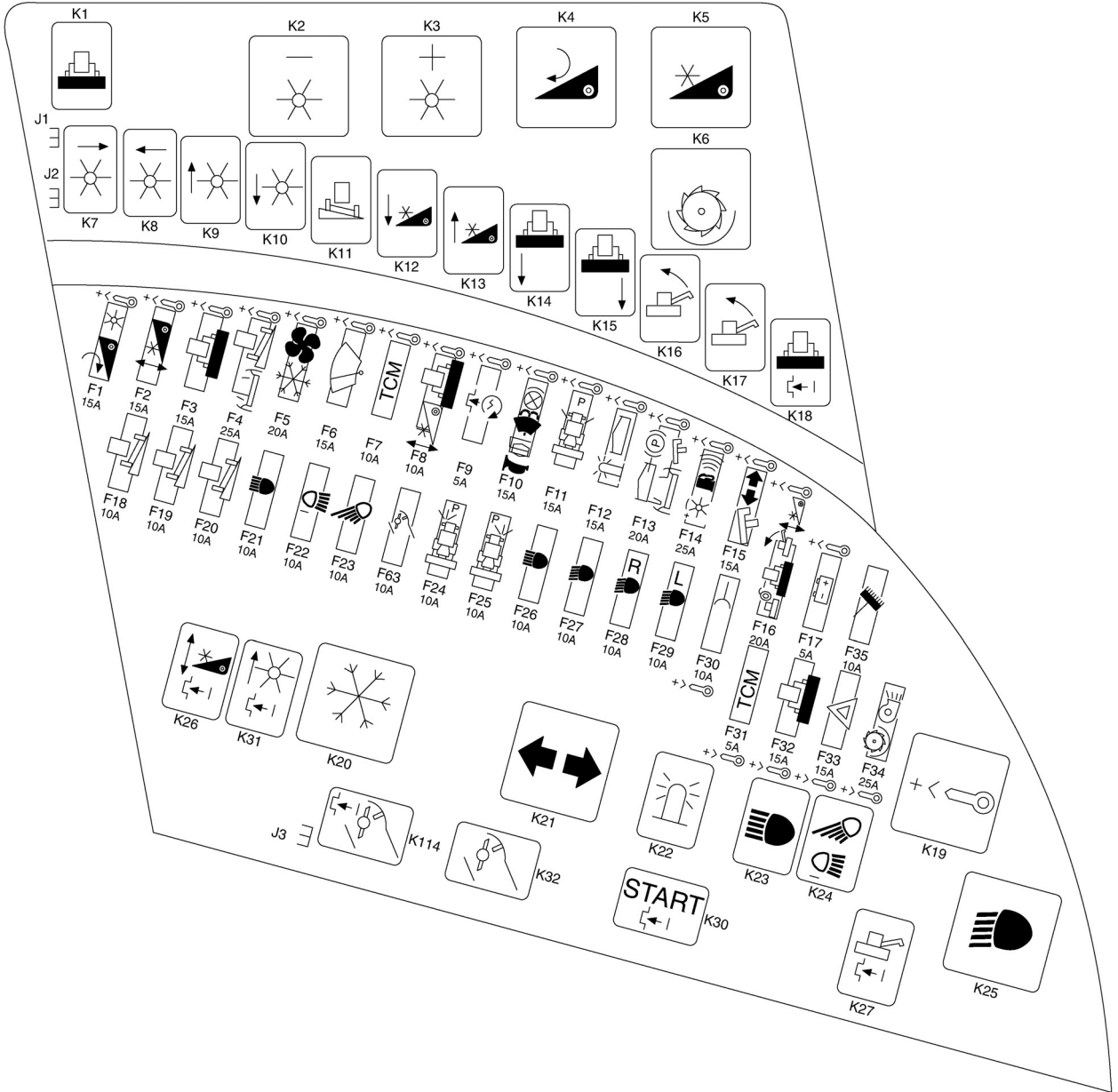

ZEIL07TC0112H0B

SECTION 4 – LUBRICATION AND MAINTENANCE

■ Fuse printed circuit

Fuse n°	Amperage	Function
F1	15A	Reel functions / reverser
F2	15A	Header up / down
F3	15A	Lateral flotation
F4	25A	After contact pilot self-levelling
F5	15A	Air conditioning
F6	15A	Screen wiper
F7	10A	After contact TCM (control module) / before contact FCM
F8	5A	Autofloat™
F9	5A	After contact ECU engine
F10	15A	Horn / lighting hazard switch / Lighting switches / Mirror adjustment / Relays worklights / seat adjustment
F11	15A	Fuse stop lights
F12	15A	Grain level indicator + revolving flash lights
F13	10A	Grain level indicator / parking brake / light in grain tank / manual control self-levelling
F14	25A	Back-up alarm / Fuel meter / Reel variator
F15	15A	Flasher lights / Light on unloading pipe
F16	20A	Lateral flotation + Header up/down + Relay header + threshing engaged
F17	5A	Excitation resistor alternator
F18	10A	–
F19	10A	–
F20	10A	–
F21	10A	Beam worklights
F22	10A	Rear worklights
F24	15A	Lighting fuel meter / Tail lights right
F25	15A	Tail lights left
F26	15A	Head lights
F27	15A	Dimmed lights
F28	10A	Worklights right
F29	10A	Worklights left
F30	15A	12V plug dashboard
F31	5A	Before contact update connector + Control Module
F32	15A	Autofloat™
F33	15A	Hazard switch for contact
F34	25A	Mechanical engagement
F35	10A	Rotary dust screen brushes
F63	10A	Straw chopper

SECTION 4 – LUBRICATION AND MAINTENANCE

Relay n°	Function
K1	Autofloat™
K2	Reel variator slowly
K3	Reel variator quickly
K4	Reel reverser
K5	Mechanical header engaged
K6	Mechanical threshing engaged
K7	Reel after
K8	Reel fore
K9	Reel up
K10	Reel down
K11	–
K12	Header down
K13	Header up
K14	Lateral flotation right down
K15	Lateral flotation left down
K16	Unloading pipe close
K17	Unloading pipe open
K18	Protection lateral flotation
K19	+ After contact
K20	Air conditioning
K21	Flasher unit
K22	Revolving flash lights
K23	Beam worklights
K24	Stubble lights
K25	Work lights
K26	Protection header down
K30	Start protection
K31	Protection reel down
K32	Straw chopper
K33	Heating
K114	Protection straw chopper

SECTION 4 – LUBRICATION AND MAINTENANCE

2. Fuses and relay located on the engine module.

To have access remove the cover (1) by loosening the three nuts.

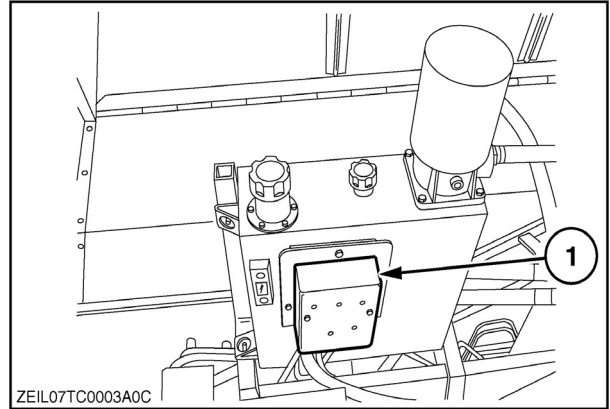

149

DELETED

Fuse	Amperage	Function
F37	40 A	Battery ECU motor
F61	80 A	Main fuse motor area

Relay	Function
K52	Starter protection relay

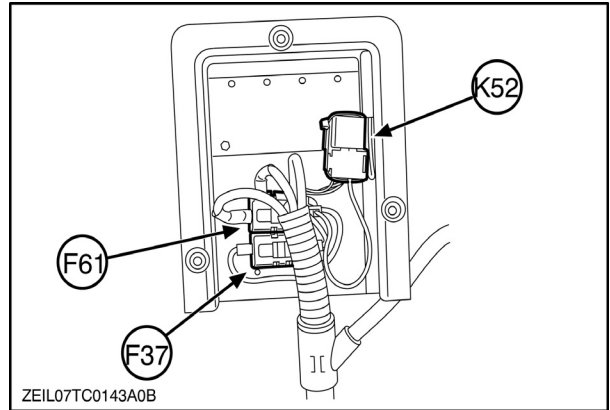

150

BATTERIES

The combine is equipped with two 12V (92 Ah) batteries. Remove the rubber cover (4) to have access to the batteries

The earth cable is connected to the battery negative pole (-).

Check weekly the battery acid level (every 50 operating hours) and, if necessary, top up with distilled water until the separators are covered.

The batteries can be completely disconnected by means of the main battery switch.

IMPORTANT: To avoid loss of data and/or monitor damage, it is strongly recommended not to stop the engine by using the battery switch. Always use the contact key in this case and wait for minimum 15 seconds before disconnect the battery switch (3).

IMPORTANT: It is advisable to disconnect the batteries at the end of the day, using the battery switch.

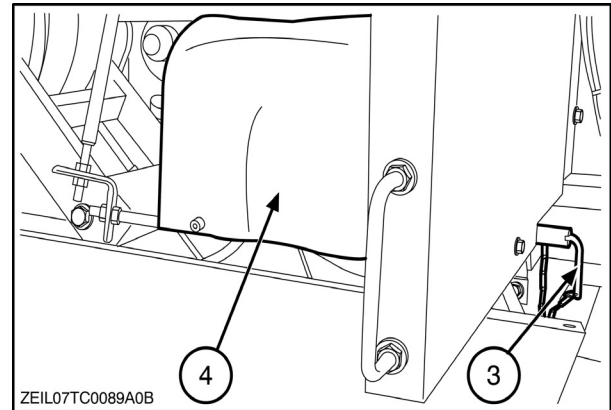

151

Important tips

1. With cold weather conditions, before starting the engine, fill the batteries with distilled water. In this way the water and the electrolytes are mixed by the charging current thus avoiding the battery freezing.



CAUTION



Keep sparks, lighted matches or an open flame away from the battery as battery gas can explode. Never check the battery charge by placing a metal object across the terminals.

Use a volt meter or a hydrometer.

2. If the engine is reluctant to start, do not turn the ignition key for longer than 20 seconds, but try again after a few seconds.
3. The battery clamps must be cleaned regularly and covered with a layer of vaseline or petroleum jelly to prevent corrosion.
4. Make sure the vents in the filler plugs are kept clean.
5. The batteries must never be disconnect while the engine is running, or damage to the alternator may result.
6. Never switch off the ignition while the engine is running on full speed. This is to prevent running out of the turbocharger propeller without lubricant.
7. To safeguard battery life, switch off any lighting before starting the engine.
8. Under normal conditions, do not add sulphuric acid to the batteries.
9. The batteries should be stored in a fully charged condition.



CAUTION



Do not charge a frozen battery as it may explode!

Battery charge warning light

As soon as the ignition switch is turned on, the battery charge warning light on the instrument panel will glow. When the engine has reached a certain speed, the light will extinguish.

If the light does not extinguish or if it flickers, the alternator or the voltage regulator may not be working properly.

Disconnect the battery terminals immediately and locate the cause of the problem or call your local dealer.

Alternator

IMPORTANT: *The engine is equipped with an alternator. Certain precautions must be observed to avoid serious damage to the alternator, battery and wiring.*

When carrying out any maintenance work, the following instructions must be observed:

1. Disconnect the negative (-) battery terminal if any electric welding work is to be carried out on the combine.

Secure the negative (-) terminal of the welding apparatus as close as possible to the part to be welded.

2. The positive (+) lead of the battery is live at all times. To prevent damage, always disconnect the battery earth lead (-) first.
3. Ensure the battery is connected properly, i.e. negative (-) lead to the negative (-) terminal and positive (+) lead to the positive (+) terminal.
4. Always connect a booster battery in parallel, i.e. negative (-) to negative (-), and positive (+) to positive (+).
5. Disconnect the earth (-) battery cable before connecting a battery charger.

Ensure the battery charger is properly connected.

6. Never run the engine if the wiring between the alternator and the battery has been disconnected.

DELETED

CAB/CLIMATE CONTROL

Cab air filter

The cab air filter should be cleaned regularly and/or daily in case of harvesting in extremely dusty conditions. Open the cab roof (4) with the lock (7) inside the cab. Release the latches (5) and remove the cab air filter (6). Clean with compressed air blown from the inside towards the outside.

It is advisable to replace the filter elements every year.

—————  **CAUTION**  —————
Wear a dust mask when doing this job.

—————  **CAUTION**  —————

Dust protection

The air filter in the cab does not protect against all substances (e.g. chemical residues on crops). Absolute protection against specific products can only be obtained when the nature of these products is known and adequate measures are purposely designed to counter the hazard created by these substances. It goes without saying that correct filter maintenance and keeping doors and windows closed is essential.

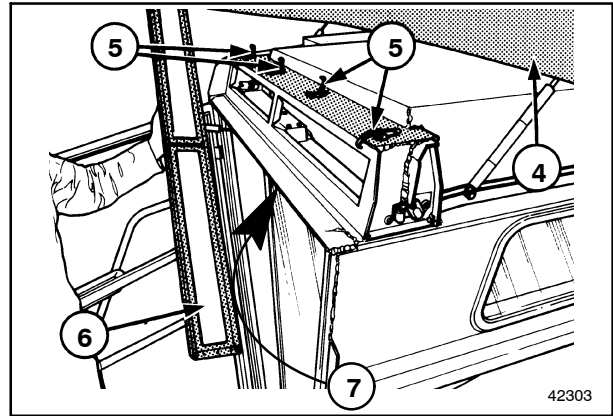

A/C SYSTEM (IF INSTALLED)

The A/C system must be started exclusively when the combine engine is warm and when inside the cab temperature reaches 21 °C or more.

NOTE: Ignoring this precaution may cause damage to the system.

To start the A/C system turn the switch (2) completely towards the right (maximum position) and the fan switch (3) onto "III" (maximum speed). The heating switch (1) must be in minimum position (i.e. completely towards left).

The fan inside the cab roof will blow air at full speed through the evaporator which is installed inside the roof.

When the air temperature feels comfortable, turn the switch (2) away from its maximum position and turn the fan switch (3) into position "I" or "II" (low to medium speed).

IMPORTANT: The switch (3) must never be turned on "I" if the A/C system switch (2) is in the maximum position (i.e. completely towards right), because this can influence negatively the system performance.

Condenser

Regularly inspect and clean the condenser (4) with compressed air.

To gain access to clean the condenser: refer to "Rotary dust screen and cooling system" in this section.

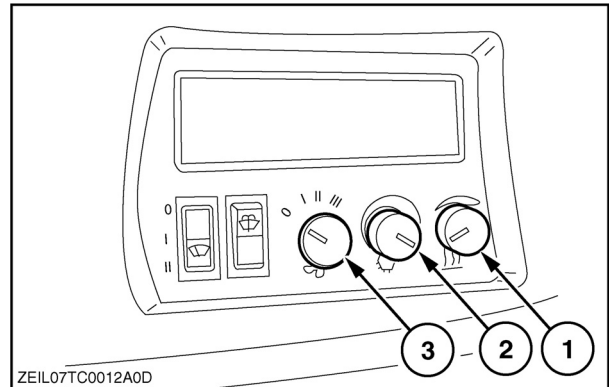

153

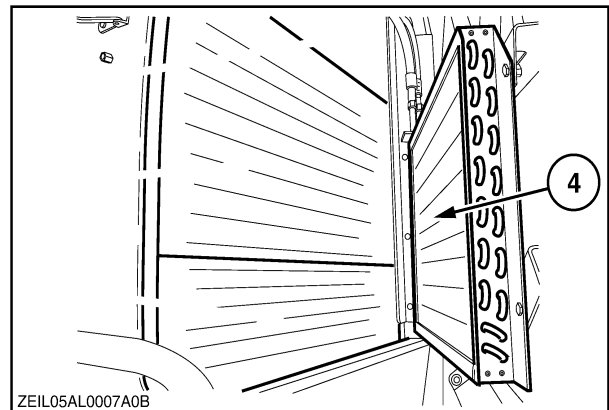

154

Evaporator

Inspect regularly the evaporator 11 inside the cab to ensure that the coils are free of foreign material. To gain access, open the cab roof, remove the mounting screws 12 and the fan cover. Remove any debris using compressed air.

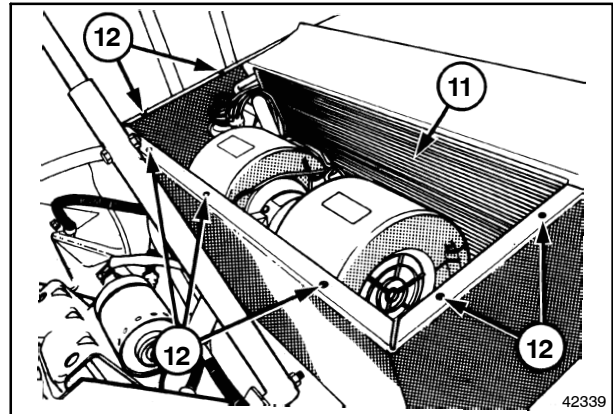

155

Filter-drier

The sight glass and a ring-shaped moisture indicator (1) on the right-hand side of the engine compartment serve for determining the condition of the R134a gas.

- If the refrigerant is without air bubbles, then the refrigerant condition is good.
- If the glass shows a milky refrigerant: good condition in ambient temperature.
- If air bubbles are visible: lack of refrigerant.
- If the moisture indicator is blue: filter and refrigerant are in good condition.
- If the moisture indicator is red: this is an indication of too much moisture, the filter-drier has to be replaced.
- If the moisture indicator is brown or black: too much contamination: filter-drier has to be replaced.

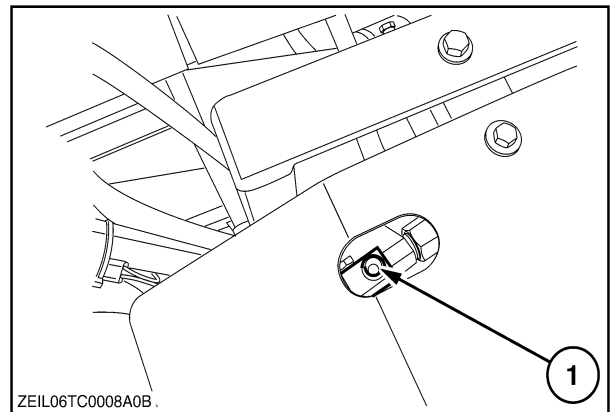

156

NOTE: The filter-drier must always be replaced when the air circuit has been opened.

If the filter-drier needs to be replaced, or if the air conditioning system needs repair, contact your local dealer.

Refer to Section 5 – FAULT FINDING.

AIR COMPRESSOR (IF INSTALLED)

The air compressor (1) is installed onto the engine and needs no further maintenance.

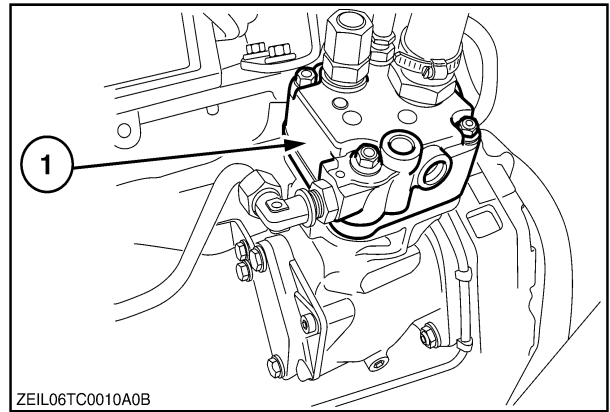

157

Every 50 operating hours, drain the condensed water from the air reservoir through cock (2).

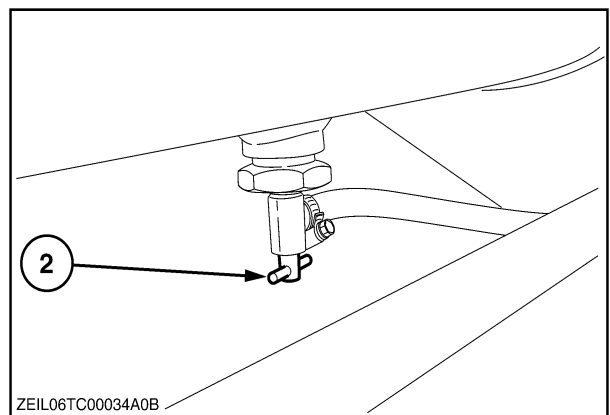

158

One union (3) is installed to attach pneumatic service tools and for cleaning purposes.

The inner thread of the union is 1/2 GAZ CYL.

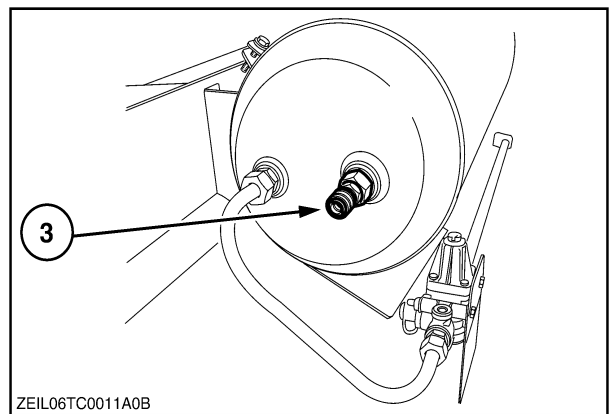

159

Air reservoir specification

(according to European Directive 87/404/EEC)

- Trade mark: Wabco
- Type: "60 l"
- Maximum operating pressure: 10 bar (145.1 PSI)
- Maximum operating temperature: +100°C (212°F)
- Minimum operating temperature: – 50°C (–58°F)
- Capacity: 60 litres (15.85 US gal)
- Approval date: see cold stamping on the air reservoir.

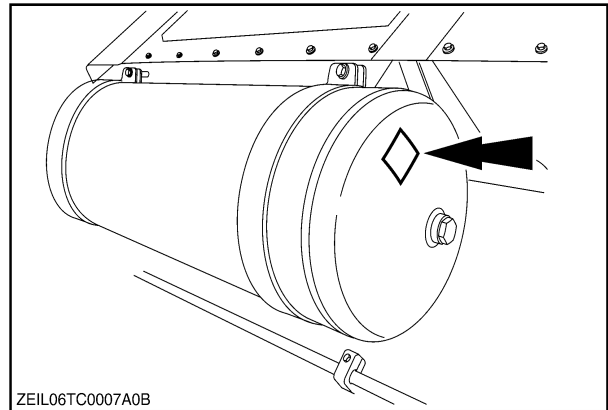

160

IMPORTANT: For France, the air reservoir must be reapproved (technical control) every 5 years. The owner has to take the necessary actions to have the reservoir retested before the expiry date which is the approval date + 5 years.

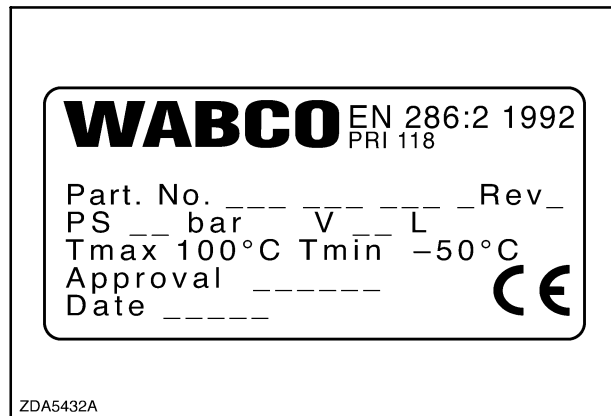

161

MAINTENANCE SCHEDULE

Service to be performed before the first start-off	SECTION
1. Check wheel nut torques	<i>SPECIFICATIONS</i>
2. Check all chain and belt tensions	<i>LUBRICATION AND MAINTENANCE</i>
3. Check all tyre pressures	<i>SPECIFICATIONS</i>
4. Check brake fluid level	<i>LUBRICATION AND MAINTENANCE</i>
5. Check engine oil level	<i>LUBRICATION AND MAINTENANCE</i>
6. Check coolant level	<i>LUBRICATION AND MAINTENANCE</i>
7. Check hydraulic oil level	<i>LUBRICATION AND MAINTENANCE</i>
8. Check hydrostatic oil level	<i>LUBRICATION AND MAINTENANCE</i>
9. Check fuel level	<i>LUBRICATION AND MAINTENANCE</i>
10. Grease all zerks	<i>LUBRICATION AND MAINTENANCE</i>

Run-in period	Service to be performed	SECTION
First week: daily	Check wheel nut torques	<i>SPECIFICATIONS</i>
After the first 50 hours	Final drives Traction gearbox Parking brake	<i>LUBRICATION AND MAINTENANCE</i>
After first 100 hours	Check the oil level	<i>LUBRICATION AND MAINTENANCE</i>
	Check the oil level	<i>LUBRICATION AND MAINTENANCE</i>
	Adjust the stroke if necessary	<i>LUBRICATION AND MAINTENANCE</i>
	Change hydrostatic oil and filter	<i>LUBRICATION AND MAINTENANCE</i>
	Change hydraulic oil and oil filters	<i>LUBRICATION AND MAINTENANCE</i>
	Change traction gearbox oil	<i>LUBRICATION AND MAINTENANCE</i>
	Change final drives gearbox oil	<i>LUBRICATION AND MAINTENANCE</i>
	Change engine oil and filter	<i>LUBRICATION AND MAINTENANCE</i>

SECTION 4 – LUBRICATION AND MAINTENANCE

Daily service to be performed (10 hour service to be performed)	SECTION
1. Perform the 10 hour grease zerk service	<i>LUBRICATION AND MAINTENANCE</i>
2. Lubricate all chains	<i>LUBRICATION AND MAINTENANCE</i>
3. Check all chain and belt tensions	<i>LUBRICATION AND MAINTENANCE</i>
4. Check engine oil level	<i>LUBRICATION AND MAINTENANCE</i>
5. Check hydraulic oil level	<i>LUBRICATION AND MAINTENANCE</i>
6. Check hydrostatic oil level	<i>LUBRICATION AND MAINTENANCE</i>
7. Check coolant level	<i>LUBRICATION AND MAINTENANCE</i>
8. Clean cab air filter	<i>LUBRICATION AND MAINTENANCE</i>
9. Check fuel level	<i>LUBRICATION AND MAINTENANCE</i>
10. Clean stone trap	<i>FIELD AND SITE OPERATION</i>
11. Drain water from fuel system prefilter/water separator	<i>LUBRICATION AND MAINTENANCE</i>

50 hour service to be performed	SECTION
1. Perform the 10 hour service (see above)	<i>LUBRICATION AND MAINTENANCE</i>
2. Perform the 50 hour grease zerk service	<i>LUBRICATION AND MAINTENANCE</i>
3. Check wheel nut torques	<i>SPECIFICATIONS</i>
4. Check steering ball joints	<i>LUBRICATION AND MAINTENANCE</i>
5. Check and clean air conditioning condenser [if fitted]	<i>LUBRICATION AND MAINTENANCE</i>
6. Check and clean air conditioning evaporator [if fitted]	<i>LUBRICATION AND MAINTENANCE</i>
7. Check air conditioning filter-drier [if fitted]	<i>LUBRICATION AND MAINTENANCE</i>
8. Check tyre pressure	<i>SPECIFICATIONS</i>
9. Check drum concave setting	<i>FIELD AND SITE OPERATION</i>
10. Check electrolyte level in batteries	<i>LUBRICATION AND MAINTENANCE</i>
11. Check brake fluid level	<i>LUBRICATION AND MAINTENANCE</i>

SECTION 4 – LUBRICATION AND MAINTENANCE

100 hour service to be performed	SECTION
1. Perform the 10 hour service (see above)	<i>LUBRICATION AND MAINTENANCE</i>
2. Perform the 50 hour service (see above)	<i>LUBRICATION AND MAINTENANCE</i>
3. Perform the 100 hour grease zerk service	<i>LUBRICATION AND MAINTENANCE</i>

DELETED

300 hour service to be performed	SECTION
1. Perform the 10 hour service (see above)	<i>LUBRICATION AND MAINTENANCE</i>
2. Perform the 50 hour service (see above)	<i>LUBRICATION AND MAINTENANCE</i>
3. Perform the 100 hour service (see above)	<i>LUBRICATION AND MAINTENANCE</i>
4. Change prefilter / water separator	<i>LUBRICATION AND MAINTENANCE</i>
5. Change fuel filter	<i>LUBRICATION AND MAINTENANCE</i>
6. Lubricate threaded rods and pivot points	<i>LUBRICATION AND MAINTENANCE</i>
7. Check steering ball joints, wheel spindles, tie rods and steering hydraulic components	<i>LUBRICATION AND MAINTENANCE</i>

SECTION 4 – LUBRICATION AND MAINTENANCE

600 hour service to be performed	SECTION
1. Perform the 10 hour service (see above)	<i>LUBRICATION AND MAINTENANCE</i>
2. Perform the 50 hour service (see above)	<i>LUBRICATION AND MAINTENANCE</i>
3. Perform the 100 hour service (see above)	<i>LUBRICATION AND MAINTENANCE</i>
DELETED	
5. Perform the 300 hour service (see above)	<i>LUBRICATION AND MAINTENANCE</i>
6. Change traction gearbox oil	<i>LUBRICATION AND MAINTENANCE</i>
7. Change final drive gearbox oil	<i>LUBRICATION AND MAINTENANCE</i>
8. Change hydraulic oil and oil filters	<i>LUBRICATION AND MAINTENANCE</i>
9. Change hydrostatic oil and oil filter	<i>LUBRICATION AND MAINTENANCE</i>
10. Replace air cleaner element of air intake system	<i>LUBRICATION AND MAINTENANCE</i>
11. Replace cab air filters	<i>LUBRICATION AND MAINTENANCE</i>
12. Check brake linings	<i>LUBRICATION AND MAINTENANCE</i>
13. Change engine oil and oil filter	<i>LUBRICATION AND MAINTENANCE</i>

2 year service to be performed	SECTION
1. Perform the 10 hour service (see above)	<i>LUBRICATION AND MAINTENANCE</i>
2. Perform the 50 hour service (see above)	<i>LUBRICATION AND MAINTENANCE</i>
3. Perform the 100 hour service (see above)	<i>LUBRICATION AND MAINTENANCE</i>
DELETED	
5. Perform the 300 hour service (see above)	<i>LUBRICATION AND MAINTENANCE</i>
6. Perform the 600 hour service (see above)	<i>LUBRICATION AND MAINTENANCE</i>
7. Change brake fluid	<i>LUBRICATION AND MAINTENANCE</i>
8. Change coolant	<i>LUBRICATION AND MAINTENANCE</i>
9. Replace safety element of air intake system	<i>LUBRICATION AND MAINTENANCE</i>

4 to 6 year service to be performed	SECTION
Replace all hydraulic hoses	<i>LUBRICATION AND MAINTENANCE</i>

SECTION 5 – FAULT FINDING

—  **WARNING**  —

Curing concerns after having found their cause with the help of this fault finding section must always be carried out with the utmost care and attention. Failure to do so may lead to severe injuries or even death.

Cleaning and unblocking activities must ALWAYS be carried out with the engine off and all rotating parts stopped.

FEEDING AREA

CONCERN	POSSIBLE CAUSE	CORRECTION
Irregular feeding into the straw elevator	Straw elevator chain set too high at the entrance	Lower straw elevator chain.
	Header drive belt slipping	Adjust belt tension.
	Slats damaged	Straighten or replace damaged slats.
The material is backed to the feed auger by the straw elevator chain	Straw elevator chain badly adjusted	Adjust chain tension.
	Stone trap clogged	Clean stone trap.
	Drum rasp bars worn	Replace rasp bars.

THRESHING AREA

CONCERN	POSSIBLE CAUSE	CORRECTION
Grain not properly threshed from heads	Crop not ripe enough	Wait until crop is in a fit condition to harvest.
	Drum speed too slow	Increase drum speed.
	Clearance between drum and concave too wide	Reduce concave clearance.
	Concave not parallel to drum	Adjust sides of concave individually until they are parallel to the drum rasp bars.
	Not enough material entering combine for proper threshing action	Lower header and/or increase ground speed.
Unthreshed heads passing through concave grate	Close concave de-awning plates to blank off front portion of the concave.	

CONCERN	POSSIBLE CAUSE	CORRECTION
Grain not properly threshed from heads	<p>Rasp bars or concave damaged, bent or worn excessively</p> <p>Irregular feeding to drum</p> <p>Beater shaft speed incorrect</p>	<p>Inspect all rasp bars and concave for excessive wear or damage.</p> <p>Check straw elevator chain position.</p> <p>Check speed of beater shaft. Correct speed = 875 rpm on TC5040–TC5050–TC5060. 850 rpm on TC5070–TC5080</p>
Material wrapping around the drum	<p>Drum speed too slow</p> <p>Beater stripper plates incorrectly adjusted</p> <p>Drum rasp bars damaged or worn</p> <p>Crop too wet or insufficiently ripe</p>	<p>Increase drum speed.</p> <p>Adjust stripper plates closer to the rasp bars.</p> <p>Replace rasp bars.</p> <p>Wait until crop is in a fit condition to harvest.</p>
Drum blockage	<p>Irregular feeding</p> <p>Drum speed too slow</p> <p>Crop too wet or insufficiently ripe</p> <p>Drum vari-drive belt slips</p> <p>Losing rpm because of sluggish or malfunctioning engine governor</p>	<p>Adjust header and straw elevator for optimum feeding.</p> <p>Increase drum speed.</p> <p>Wait until crop is in a fit condition to harvest.</p> <p>Check drum variator for deformation or incorrect adjustment. Tighten tensioning spring, if necessary.</p> <p>Fuel injection pump should be checked by a specialist.</p>

THRESHING, SEPARATION AND CLEANING

CONCERN	POSSIBLE CAUSE	CORRECTION
<p>Excessive cracked grain in tank</p>	Drum speed too fast	Decrease drum speed sufficiently to stop cracking, yet still thresh all the grains from the heads, and/or open concave slightly.
	Excessive tailings	See the concern described under “Excessive tailings”.
	Concave clogged, or openings blocked by de-awning plates	Clean concave and remove de-awning plates.
	Concave not parallel to drum	Adjust sides of concave individually until they are parallel to the drum.
	Grain being cracked in grain elevator	Adjust grain elevator chain tension.
	Clearance between drum and concave too small	Increase concave clearance just enough to eliminate cracking. Decrease drum speed slightly.
	Uneven feeding, or wads entering drum	Adjust straw elevator chain. Check feed auger height and retractable finger adjustment.
	Not enough material entering combine	Lower header and increase ground speed.
Damaged bottom auger housing	Repair damaged housing.	

CONCERN	POSSIBLE CAUSE	CORRECTION
<p>Grain loss over straw walkers</p>	<p>Straw walkers running at incorrect speed</p> <p>Straw walkers overloaded due to excessive ground speed</p> <p>Crop too wet or contains excessive green material</p> <p>Straw walker openings blocked so grain cannot drop through</p> <p>Concave blocked allowing excessive grain to be thrown onto the straw walkers</p>	<p>Check speed of beater shaft. Correct speed = 875 rpm on TC5040–TC5050–TC5060. 850 rpm on TC5070–TC5080</p> <p>Reduce ground speed to reduce amount of material entering combine. Raise the header. Increase concave-to-drum clearance if straw walkers have become dogged due to the straw being broken up excessively.</p> <p>It may be necessary to reduce concave-to-drum clearance if overloading is the result of incomplete threshing. In this case, it may also be desirable to increase the drum speed.</p> <p>Wait until crop is in fit condition to harvest.</p> <p>Clean straw walker openings.</p> <p>Clean concave thoroughly.</p>
<p>Grain is not properly cleaned</p>	<p>Lower sieve opening too wide, allowing trash to fall into the clean grain auger</p> <p>Cleaning fan vari-drive belt slipping</p> <p>Beater shaft speed incorrect</p>	<p>Reduce lower sieve opening.</p> <p>Check fan variator adjustment.</p> <p>Check speed of beater shaft. Correct speed = 875 rpm on TC5040–TC5050–TC5060. 850 rpm on TC5070–TC5080</p> <p>Check also whether the cleaning shoe drive belt is slipping.</p>

CONCERN	POSSIBLE CAUSE	CORRECTION
<p>Grain is not properly cleaned</p>	<p>Wind deflectors incorrectly adjusted</p> <p>Insufficient air blast from cleaning fan</p> <p>Lower sieve overloaded or blocked</p> <p>Upper sieve opened too wide, allowing excessive trash to fall onto lower sieve</p> <p>Drum speed too high, or concave clearance too small, or a combination of both, resulting in chopped straw overloading the sieves</p>	<p>Position deflectors on the factory setting.</p> <p>Increase fan speed to the point that grain is being cleaned properly, but not blown over the rear of the sieves.</p> <p>Clean the sieve thoroughly.</p> <p>Close upper sieve so that only the clean grain falls onto the lower sieve and most of the trash moves out over the rear of the upper sieve.</p> <p>If closed too far, threshed grain will be lost over the rear of the sieve.</p> <p>Readjust drum speed and concave clearance so that the straw is not broken up excessively, but so that all the grain is threshed from the heads.</p>
<p>Grain loss over the sieves</p>	<p>Too much air blast from the cleaning fan</p> <p>Wind deflectors incorrectly adjusted</p> <p>Upper sieve not opened wide enough</p> <p>Upper sieve blocked</p> <p>Lower sieve not opened wide enough or blocked, causing excessive grain to enter returns and be rethreshed</p> <p>Crop not in a fit condition to harvest, or contains too much green material</p>	<p>Reduce air blast with fan variable speed control.</p> <p>Position deflectors on the factory setting.</p> <p>Open the upper sieve so that all the clean grain moves to the lower sieve.</p> <p>Clean upper sieve.</p> <p>Open the lower sieve and clean if it is blocked.</p> <p>Raise header to prevent as much green material as possible from entering combine, or wait until crop is in a fit condition to harvest.</p>

CONCERN	POSSIBLE CAUSE	CORRECTION
<p>Grain loss over the sieves</p>	<p>Grain pan dirty Sieves overloaded</p> <p>Cleaning shoe drive belt slipping Beater shaft speed incorrect</p> <p>Cleaning shoe not level (self-levelling cleaning shoe only)</p>	<p>Clean grain pan.</p> <p>See concern described under “Sieves overloaded”, below.</p> <p>Adjust cleaning shoe belt tension.</p> <p>Check speed of beater shaft. Correct speed = 875 rpm on TC5040–TC5050–TC5060. 850 rpm on TC5070–TC5080</p> <p>Check electric control. Contact your local dealer.</p>

GENERAL PROBLEMS

CONCERN	POSSIBLE CAUSE	CORRECTION
<p>Blockage of machine</p>	<p>Beater shaft speed incorrect</p> <p>Crop not in a fit condition to harvest, or too much green material in crop</p> <p>Concave incorrectly adjusted</p> <p>Rasp bars or concave damaged or worn excessively</p> <p>Irregular feeding.</p>	<p>Check speed of beater shaft. Correct speed = 875 rpm on TC5040–TC5050–TC5060. 850 rpm on TC5070–TC5080</p> <p>Raise header to reduce amount of green material entering the combine, or wait until crop is in a fit condition to harvest.</p> <p>Increase drum-to-concave clearance. Ensure concave is parallel to the drum.</p> <p>Inspect all rasp bars and concave for excessive wear or damage. Replace, if necessary.</p> <p>Adjust ground speed to permit even feeding.</p> <p>Check straw elevator chain tension</p>

CONCERN	POSSIBLE CAUSE	CORRECTION
<p>Blockage of machine</p>	<p>Belts slipping</p> <p>Drum vari-drive belt slips</p> <p>Belt or chain broken</p>	<p>Check all belt drives. Tighten belts, as required.</p> <p>Check drum variator for deformation or incorrect adjustment.</p> <p>Tighten tensioning spring, if necessary.</p> <p>Replace broken belt or repair chain.</p>
<p>Excessive tailings</p>	<p>Lower sieve closed too much, or blocked</p> <p>Air blast too strong from the cleaning fan</p> <p>Wind deflectors incorrectly adjusted</p> <p>Eccentric shaft speed incorrect</p> <p>Overthreshing</p>	<p>Open lower sieve slightly and clean thoroughly, if blocked.</p> <p>Reduce the fan speed.</p> <p>Position deflectors on the factory setting.</p> <p>Check cleaning shoe drive belt tension.</p> <p>Reduce drum speed and/or increase drum-to-concave clearance to prevent straw from being chopped up excessively.</p>

CONCERN	POSSIBLE CAUSE	CORRECTION
<p>Sieves overloaded</p>	<p>Beater shaft speed incorrect</p> <p>Cleaning shoe drive belt slipping</p> <p>Insufficient air blast from the fan</p> <p>Upper sieve open too narrow or blocked</p> <p>Overthreshing</p> <p>Wind deflectors incorrectly adjusted</p>	<p>Check speed of beater shaft. Correct speed = 875 rpm on TC5040–TC5050–TC5060. 850 rpm on TC5070–TC5080</p> <p>Check all belt drives and adjust tension, as required.</p> <p>Increase fan speed.</p> <p>Open sieve slightly and clean thoroughly, if blocked.</p> <p>Reduce drum speed and/or increase drum-to-concave clearance to reduce the amount of short straw on the upper sieve.</p> <p>Do not make these adjustments too extreme, or underthreshing may result.</p> <p>Position deflectors on the factory setting.</p>

ENGINE

CONCERN	POSSIBLE CAUSE	CORRECTION
Engine will not start	<p>Insufficient fuel in tank</p> <p>Battery connections dirty or disconnected</p> <p>Battery partly run down</p> <p>Air in fuel system</p> <p>Faulty lift pump</p> <p>Restricted fuel filter</p> <p>Restricted prefilter/water separator</p> <p>Dirty or defective injectors</p> <p>Faulty injection pump setting</p> <p>Poor compression</p> <p>Polluted fuel</p>	<p>Fill up fuel tank.</p> <p>Connect, clean and coat with vaseline the battery connections.</p> <p>Charge battery.</p> <p>Bleed fuel system.</p> <p>Check lift pump.</p> <p>Replace fuel filter.</p> <p>Replace element.</p> <p>Contact your local dealer.</p> <p>Contact your local dealer.</p> <p>Contact your local dealer.</p> <p>Drain and clean fuel tank. Refill with clean fuel.</p>
Engine does not give full power	<p>Dirty air cleaner</p> <p>Restricted fuel filter</p> <p>Dirty or defective injectors</p> <p>Restricted exhaust pipe</p>	<p>Clean air cleaner.</p> <p>Replace fuel filter.</p> <p>Contact your local dealer.</p> <p>Clean or replace exhaust pipe.</p>

CONCERN	POSSIBLE CAUSE	CORRECTION
Engine does not give full power	Injection timing incorrect Incorrect valve clearance Faulty injection pump Poor compression Vent hole in fuel tank filler cap clogged Polluted fuel	Contact your local dealer. Contact your local dealer. Contact your local dealer. Contact your local dealer. Clean vent hole. Drain and clean fuel tank. Refill with clean fuel.
Engine overheats	Insufficient coolant Dirty radiator Fan belt slack or broken Rotary screen clogged Thermostat sticking Fuel injection timing incorrect Faulty or dirty fuel injectors Insufficient oil in engine sump Defective cylinder head gasket	Add coolant. Clean radiator. Adjust belt(s) tension, or replace belt. Clean the screen. Contact your local dealer. Contact your local dealer. Contact your local dealer. Add oil. Contact your local dealer.

CONCERN	POSSIBLE CAUSE	CORRECTION
Engine knocks	Faulty or dirty injectors Incorrect injection timing Broken valve springs Faulty injection pump Piston slap Bearing(s) worn	Contact your local dealer. Contact your local dealer. Contact your local dealer. Contact your local dealer. Contact your local dealer. Contact your local dealer.
Exhaust emits excessive smoke	Incorrect fuel injection timing Faulty or dirty injectors Faulty injection pump Poor compression Wrong engine timing	Contact your local dealer. Contact your local dealer. Contact your local dealer. Contact your local dealer. Contact your local dealer.
Engine will not idle	Air in fuel system Broken injector pipe Dirty or defective injectors Broken or sticking piston rings Sticking valves Faulty injection pump	Bleed fuel system. Contact your local dealer. Contact your local dealer. Contact your local dealer. Contact your local dealer. Contact your local dealer.
Engine runs only at 1500 rpm	CAN connection error	Contact your local dealer.

CONCERN	POSSIBLE CAUSE	CORRECTION
Engine starts, then stops	Air in fuel system Fuel filters restricted Faulty lift pump Sticking valves Incorrect injection pump	Bleed fuel system. Replace filters. Check lift pump. Contact your local dealer. The injection pump should be checked. Contact your local dealer.
Insufficient oil pressure	Insufficient oil Sender unit defective Oil pressure gauge defective Main bearings worn	Add oil. Replace sender unit. Contact your local dealer. Replace oil pressure gauge. Contact your local dealer. Contact your local dealer.
Battery will not charge	Corroded or loose connections Loose alternator drive belt Alternator or voltage regulator not working properly	Check and tighten connections. Contact your local dealer. Contact your local dealer.
Air conditioning will not cool	Fuse no. 5 blown Condenser plugged externally Evaporator plugged externally	Check for cause and replace fuse. Clean condenser. Clear evaporator. Contact your local dealer or a specialist for assistance.

STRAW CHOPPER [if fitted]

CONCERN	POSSIBLE CAUSE	CORRECTION
Chopper vibrates during operation	<p>The chopper rotor touches the side of the combine straw hood</p> <p>Rotor knife damaged or broken</p> <p>Rotor bearing broken</p> <p>Frame cross bars not installed</p> <p>Rotor out of balance</p> <p>Knives of different thickness installed</p>	<p>Straighten the straw hood and readjust the chopper so that the rotor runs freely.</p> <p>Replace damaged or broken rotor knife.</p> <p>Replace rotor bearing. Contact your local dealer.</p> <p>Install frame cross bars.</p> <p>Ensure all knives are swinging freely, are undamaged and equally worn. Clean rotor properly. If this does not solve the problem, contact your local dealer.</p> <p>Replace incorrect knives.</p>
Poor chop quality, i.e. too long	<p>Damaged knife or knives on rotor and counter knives bar</p> <p>Dull rotor knives and counter knives</p> <p>Incorrect rotor speed</p> <p>Wrong position of counter knives bar</p>	<p>Replace damaged knives and sharpen counter knives.</p> <p>Turn, or replace, rotor knives. Sharpen or replace counter knives.</p> <p>Rotor speed must be 3400 rpm minimum (on standard speed). Check belt tension.</p> <p>Correct position.</p>
Spread pattern too wide, or too narrow	Adjustment error	Adjust spreader fins for correct spread pattern.

CONCERN	POSSIBLE CAUSE	CORRECTION
Straw chopper gets blocked	<p>Dull knives</p> <p>Belts slack</p> <p>Straw spreader fins incorrectly installed, or damaged</p> <p>Clutch slips</p> <p>Incorrect belts used</p> <p>Warning alarm defective (accumulation of straw in the straw hood)</p> <p>Straw chopper incorrectly adjusted to the crop being harvested</p>	<p>Sharpen or replace counter knives. Replace, or turn, rotor knives.</p> <p>Tension belts correctly.</p> <p>Install fins correctly, or repair.</p> <p>Adjust and, if necessary, replace worn parts. Contact your local dealer.</p> <p>Use correct belts.</p> <p>Repair warning alarm. Contact your local dealer.</p> <p>Adjust straw chopper, as described in this manual.</p>
Chopper will not engage	<p>Clutch not engaged</p> <p>Belts not tensioned</p> <p>Clutch failure</p>	<p>Engage the clutch</p> <p>Tension belts</p> <p>Contact your local dealer</p>
Belts flapping	<p>Belt guides and/or idler incorrectly adjusted</p>	<p>Adjust belt guides and idler correctly.</p>

HEADER HEIGHT CONTROL – ERROR MESSAGES

Error Code	Short description	Description
Severe error		
11	Lifting limit switch	The limit switch of the lifting magnet is faulty or the magnet line is interrupted downstream the connector.
12	Lowering limit switch	The limit switch of the lowering magnet is faulty or the magnet line is interrupted downstream the connector.
13	Short circuit of the magnet current	The current measured at the connector is too high. – Possible magnet short circuit.
14	Wire break in the magnet connector	On the connector no current is measured even though the magnet is live. – Possible break of the power wires towards the solenoid valves – Faulty magnet – No battery tension on the connector (faulty fuse).
15	Lifting / Lowering / Quick control	Control signal not OK, see Lifting / Lowering / Quick control.
16	Stabilized power	Incorrect component power. 10 V or ground power not OK.
17	Battery	Battery voltage higher than 19 V
18	Switch	Switch signal not OK. Wire break and/or signal disconnected.

Error Code	Short description	Description
Mean error		
21	Position sensor	Position signal not OK – Wire break and/or position sensor disconnected – Possible short circuit or ground connection – Position sensor adjustment not OK
22	Distance and position rated potentiometer	Rated potentiometer signal not OK Wire break and/or potentiometer disconnected
23	Pressure sensor	Pressure sensor signal not OK Wire break and/or sensor disconnected This error does not occur only when the pressure adjustment has been pre-selected.
24	Pressure rated potentiometer	Rated potentiometer signal not OK Wire break and/or potentiometer disconnected
Slight error		
31	Right Autofloat™ sensor	Right Autofloat™ sensor signal [optional] not OK – Wire break and/or sensor disconnected – Possible short circuit or ground connection
32	Left Autofloat™ sensor	Left Autofloat™ sensor signal not OK – Wire break and/or sensor disconnected – Possible short circuit or ground connection
33	Right-hand / left-hand and automatic control button	Control button signal from switch (5) and (7) not OK. – Broken and/or disconnect wire Control button for right, left or automatic swinging faulty function.
34	Valve for accumulator	Valve for accumulator not closed
36	Faulty valve and/or no oil pressure	Notwithstanding the enabled lifting current on the connector of the EHRD box, the cylinders do not lift. Is the engine running? If yes, the oil pressure is unlikely to be present or the valve is likely to be obstructed.
41	"Left tilting" valve	Left tilting valve disconnected
42	"Right tilting" valve	Right tilting valve disconnected

MACHINE – ERROR MESSAGES

Error code	Description
E101	Ground speed sensor shorted to ground
E102	Ground speed sensor shorted to battery voltage
E103	Ground speed sensor line open
E104	Drum speed sensor shorted to ground
E105	Drum speed sensor shorted to battery voltage
E106	Drum speed sensor line open
E107	Fan speed sensor shorted to ground
E108	Fan speed sensor shorted to battery voltage
E109	Fan speed sensor line open
E110	Straw walker speed sensor shorted to ground
E111	Straw walker speed sensor shorted to battery voltage
E112	Straw walker speed sensor line open
E113	Returns elevator speed sensor shorted to ground
E114	Returns elevator speed sensor shorted to battery voltage
E115	Returns elevator speed sensor line open
E116	Straw chopper speed sensor shorted to ground
E117	Straw chopper speed sensor shorted to battery voltage
E118	Straw chopper speed sensor line open
E201	Coolant temperature sensor shorted (TC5040 - TC5050 – TC5060)
E202	Coolant temperature sensor line open (TC5040 - TC5050 – TC5060)
E301	Threshing valve output (remote control only)
E302	Header valve output (remote control only)
E303	Unload tube valve output (remote control only)

ENGINE – ERROR MESSAGES

Error code Alarm message	Description
F559	Coolant temperature sensor
F560	Coolant temperature sensor dynamic test
F562	Boost pressure sensor
F563	Fuel temperature signal
F564	Oil pressure sensor
F566	Oil temperature sensor
F596	Open oil pressure sensor (only TC5070 - TC5080)
F705	Atmospheric pressure sensor
StEP	Engine rear ladder is down at contact on
SEAt	Operator not present alarm
OIL/StOP	Low engine oil pressure alarm
HEAt/StOP	Excessive coolant temperature alarm
HYDP/StOP	Hydrostatic low oil pressure alarm
HYDt/StOP	Excessive hydrostatic oil temperature alarm
FUEL/HOt	High fuel temperature alarm (> 70°C) = low level fuel tank
SHUUn/StOP	Shunttank level alarm
bAtt/StOP	Battery no charge alarm

SECTION 6 – VEHICLE STORAGE

Your combine represents an important investment and its life depends upon how well you take care of it.

END-OF-SEASON SERVICE

Follow the steps outlined below at the end of each season's use or when the machine will not be used for an extended period of time. This will ensure the combine is kept in good condition and ready for the next season.

1. Remove the head to facilitate cleaning.
2. Clean the interior and exterior of the combine thoroughly because any chaff and dirt left in the machine will attract moisture and cause rust.

NOTE:

- *Avoid pressure washing at ambient temperatures below 10° C (50° F). Place the machine in a heated workshop for at least 24 hours.*
- *Avoid direct water jets onto electric equipment, bearings, seals, gearbox, oil tank or fuel tank filler caps, into the engine exhaust, engine, cab air filters and decals.*
- *When using a high pressure washer spray:*
 - Keep a minimum distance of 30 cm (11") between the spray gun and the surface to be cleaned.
 - Spray under an angle of minimum 25° (do not spray in perpendicular direction).
 - Maximum water temperature: 60°C (140°F).
 - Maximum water pressure: 60 bar (870 PSI)
Do not use chemicals.
 - Legislation in certain countries and good practice requires special treatment of waste water through sedimentation and oil separation and controlled removal of residues.

Leave covers open at the bottom of the elevators to allow any moisture to drain out. Leave the unloading auger cleaning doors open.

DELETED

3. Remove the sieves, clean them and coat with oil or a rust preventative.
4. Remove all chains. Clean and coat the chains with oil. Reinstall them, then adjust to the correct tension.
5. Lubricate the machine thoroughly, as described in Section 4 - LUBRICATION AND MAINTENANCE.
6. Coat all bright parts (except the pulley and the variator discs) with paint, a rust preventative, oil or grease to protect them from rust.

SECTION 6 – VEHICLE STORAGE

7. Retract all hydraulic cylinders and coat exposed parts of the cylinder rods with grease.
8. Clean all belts, then check belt tension. Adjust if necessary.

DELETED

9. Clean the air filter element.
10. Use compressed air, or water under pressure, to clean out the engine radiator. Use a low-pressure water jet, or compressed air, to clean the air-conditioner condenser fins.
11. Check the anti-freeze content in the engine cooling system.
12. Fill the fuel tank completely.
13. Store the combine in a dry place, protected from the weather.
14. Close off all engine openings with plugs or greaseproof paper.
15. Support the combine on wooden blocks to relieve the weight from the tires. Leave tires inflated.
16. Disconnect the battery cables. Clean and charge the batteries.

IMPORTANT: The batteries should be charged every 8 to 10 weeks with a 5 to 6 amperes current for a period of 24 hours to a minimum of 12.6 volt.

NOTE: Removing the batteries will not harm the storage of information in the monitor.

17. Straw chopper: Remove all knives and bushings, grease them thoroughly and reinstall them onto the rotor. Torque nuts between 110 and 120 Nm (81 and 88 ft.lbs).
18. Every 4 weeks, remove the engine opening seals, start the engine and run at 3/4 throttle for 1 to 2 hours. Move all the variators from minimum to maximum, and vice versa, to ensure adequate lubrication to prevent rust.
19. Switch on the air conditioning while the engine is running, only if the ambient temperature is above 15°C (60°F). This will ensure lubrication of the compressor parts. Operate the air-conditioning system for at least 15 minutes.
20. Reinstall the engine opening seals.

Periodic checks will help to keep your combine maintenance and repairs to a minimum and avoid costly breakdowns during the season. Therefore, it is good practice to have the combine inspected at the end of the season. Your NEW HOLLAND dealer will gladly quote a price for this work.

ORDERING PARTS AND/OR ACCESSORIES

When preparing the combine for storage, check thoroughly for any parts that may have become worn and need replacing.

Parts and/or Accessories should be ordered at once and fitted before the next harvesting season.

When ordering Parts and/or Accessories, always ensure to give your NEW HOLLAND dealer the model number and PIN number of your combine. See the chapter headed “Product Identification”.

INSIST ON GENUINE NEW HOLLAND “QUALITY” PARTS AS THEY WILL GIVE THE BEST PERFORMANCE AND ARE COVERED BY OUR WARRANTY.

FOR BEST PERFORMANCE YOUR COMBINE SHOULD BE SERVICED BY AN AUTHORIZED NEW HOLLAND DEALER.

PRE-SEASON SERVICE

Follow the steps outlined below at the beginning of each season to ensure the machine is in good condition and ready for use.

1. Remove the wooden blocks supporting the combine.
2. Check the tire pressures and wheel nuts torque.
3. Lubricate the machine, as detailed in the “Lubrication Schedule”.
4. Check all belt and chain tensions (including the straw elevator and grain elevator chain).
5. Remove the protective oil from the sieves and re-install them in the machine.

6. Check the oil level of the following and add oil, if needed:

- Traction gearbox
- Final drive gearboxes
- Brake fluid reservoir
- Clutch fluid reservoir
- Hydrostatic and/ or hydraulic reservoir

DELETED

SECTION 7 – ACCESSORIES

FEEDING

Grain header illumination kit

A grain header illumination kit is available.

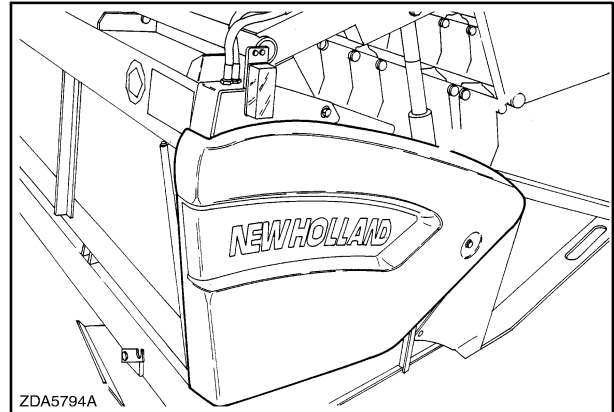

1

Quick release coupler

A quick release coupler is available to connect the hydraulic components of the combine with the header attached.

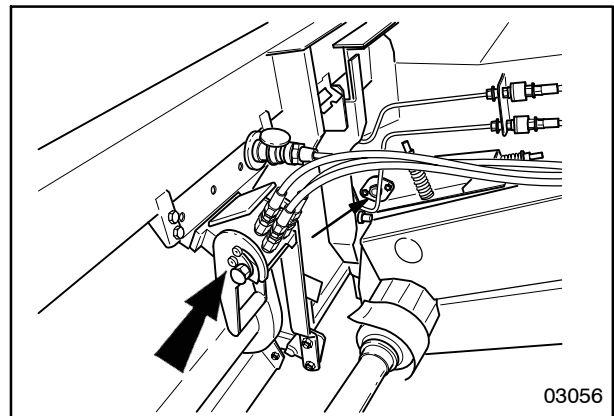

2

STRAW ELEVATOR

Anti-wrap shields

Anti-wrap shields can be installed onto the upper shaft of the straw elevator to harvest rice or damp straw conditions.

Rice kit for fixed straw elevator

Rice kit for lateral float straw elevator

Narrowing plates can be installed to harvest rice or damp straw conditions.

Third header lift cylinder

When a maize header is used, it is necessary to install a third header lifting cylinder (only on models with five straw walkers).

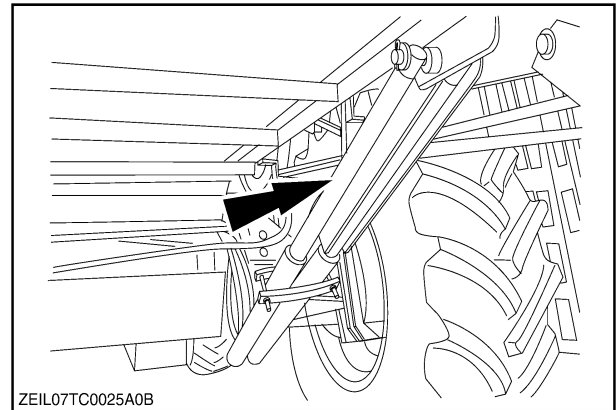

THRESHING AND SEPARATION

Straw walker vertical cover plates

In crops with short brittle straw it may be necessary to cover all the vertical apertures on the straw walkers. This will reduce the amount of material on the sieves and provide a cleaner sample.

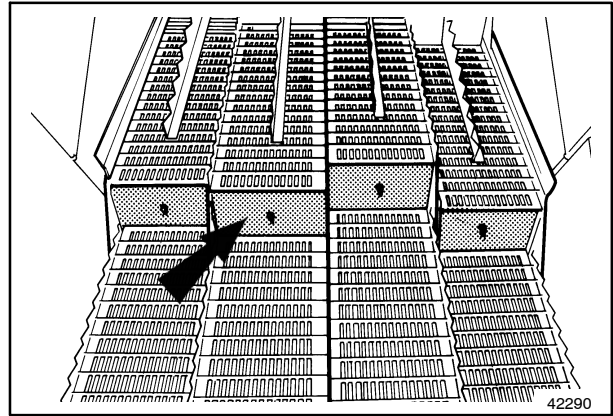

42290

DELETED

De-awning slats

Two de-awning slats can be fitted in the front section of the threshing concave to improve threshing efficiency in difficult to thresh crops.

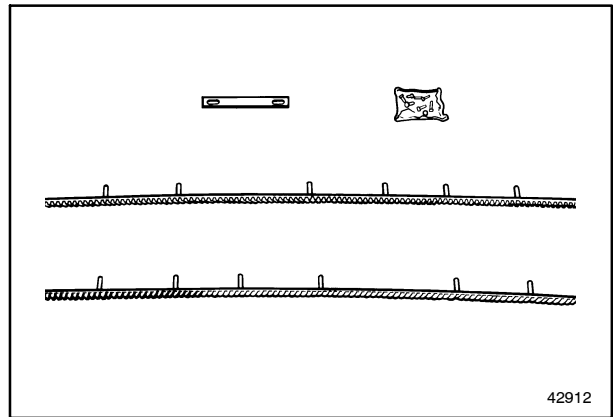

42912

4

5

De-awning plates

The de-awning plates increase the rubbing action of the drum and concave when threshing winter barley or difficult to thresh crops.

Depending on the needs, two or four de-awning plates can be installed.

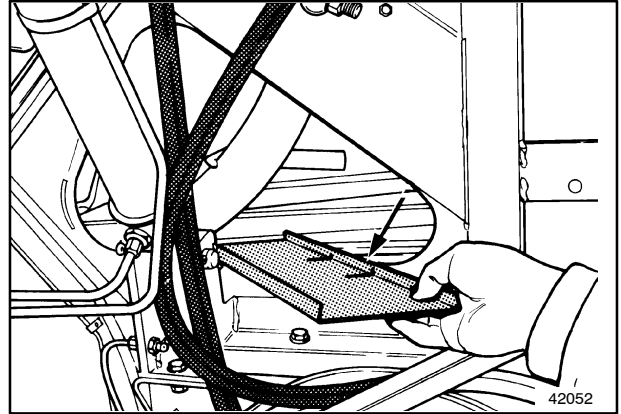

6

Beater pins

Beater pins can be installed to reduce grain crackage.

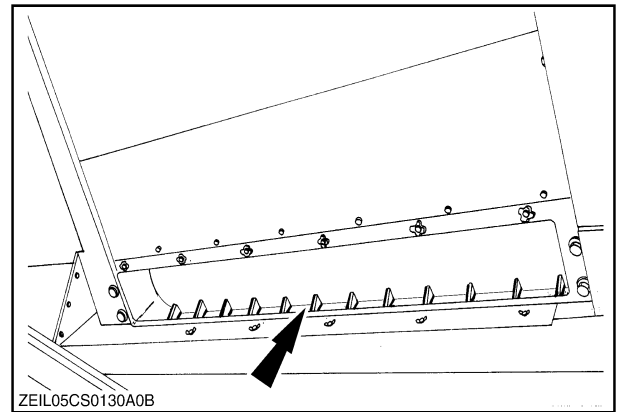

7

Cereal threshing rebuild kit

This equipment must be installed when the conversion from rice to cereal threshing is needed:

It consists of:

- de-awning plates
- standard drum
- stone trap tube
- standard concave

Rice threshing rebuild kit

This equipment must be installed when the conversion from cereal to rice threshing is needed:

It consists of:

- rice drum
- rice concave
- cleaning fan bottom shield
- anti-wrap shields
- rotary separator wear plates (if rotary separator)

Maize threshing rebuild kit

For harvesting maize it is necessary to install the following equipment:

- Rebuild from rice to maize: the kit consists of:
 - maize concave and fixed suspension
 - drum cover plates (see fig. 8)
 - standard drum
 - stone trap tube
- Rebuild from cereals to maize: the kit consists of:
 - maize concave and fixed suspension
 - drum cover plates
 - cleaning fan bottom shield

DELETED

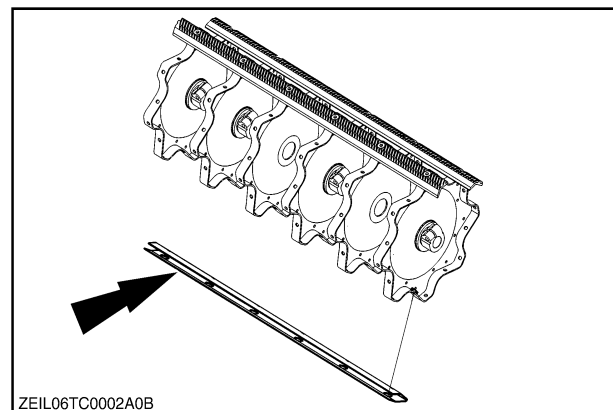

Maize special dry conditions

- maize concave and fixed suspension
- drum cover plates
- stone trap cover plate
- spike tooth beater

CLEANING SYSTEM

■ **Upper sieve HC 1-5/8" (FS+SL)**

This sieve is recommended as upper sieve when harvesting maize.

DELETED

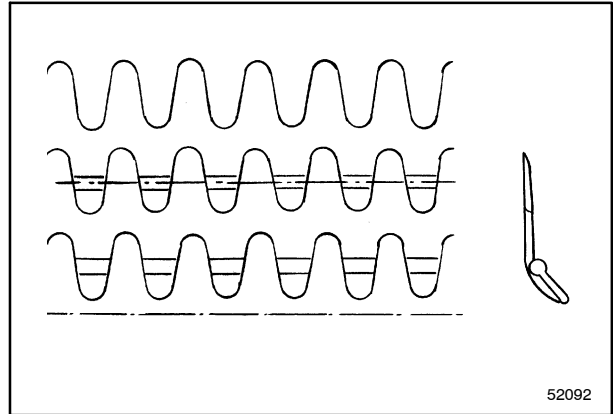

9

Round hole sieves

The following round hole sieves are available:

- 3.5 mm diameter holes: for use when harvesting small seeds (used as lower sieve)
- 16 mm diameter holes: for use when harvesting damp maize (used as upper sieve)
- 18 mm diameter holes: for use when harvesting damp maize (used as upper sieve)

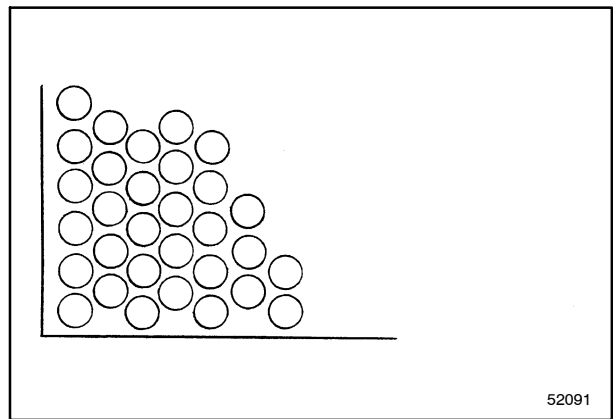

10

■ **Graepel sieve extension (fixed cleaning shoe)**

■ **Graepel sieve extension (self-levelling cleaning shoe)**

This extension can be fitted at the rear of the upper sieve instead of a finger rake to prevent short straw and weed from passing into the returns auger.

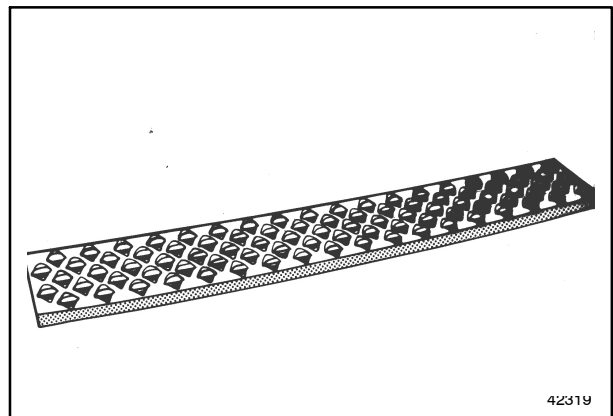

11

Cleaning fan bottom shield

This shield can be fitted for harvesting maize, sunflower, soya, beans, etc., to protect the fan bottom.

NOTE: This bottom shield is included in the rice threshing equipment.

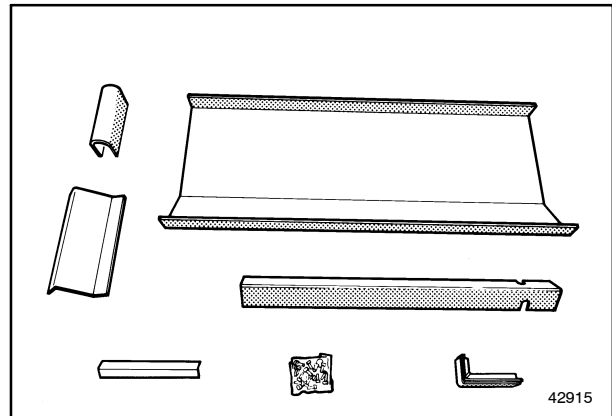

12

Grass seed equipment

This equipment will improve the combine performance while threshing small seeds.

It consists of:

- fan blanking-off plates
- beater rake cover plate
- grain pan rake cover plate
- Graepel sieve extension
- canvas on sieve end
- sweeper plates on the unloading auger
- auger flight part (for grain header)

**Extended dividers
(only for units with fixed upper sieve)**

These are recommended when operating in hilly conditions to prevent material from flowing to one side of the upper sieve and causing grain losses. The dividers are bolted in vertical position between the sieve sections.

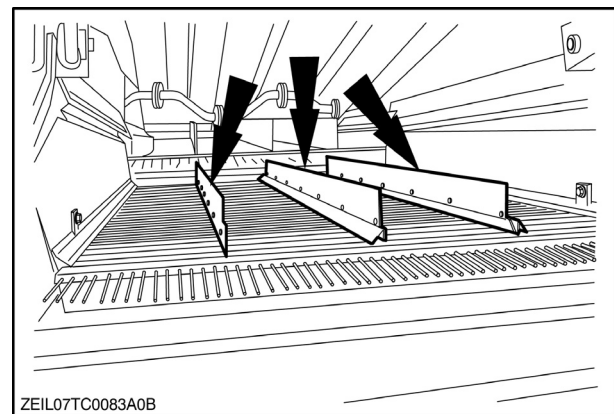

13

DELETED

CLEAN GRAIN, GRAIN TANK AND UNLOADING

Perforated covers under augers and elevators

These covers are recommended when threshing beans, peas or soya to obtain a cleaner grain sample.

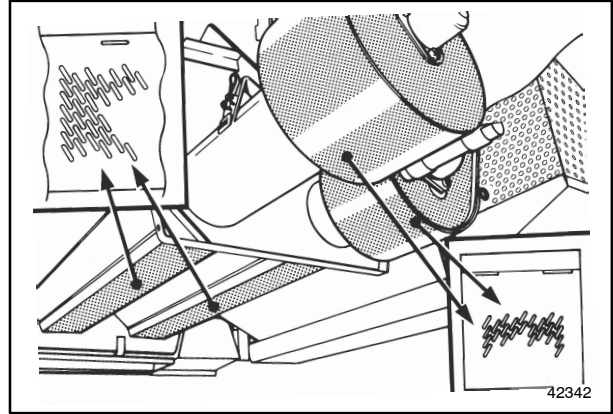

14

Grain tank level sensor

This system warns the operator when the grain tank is full.

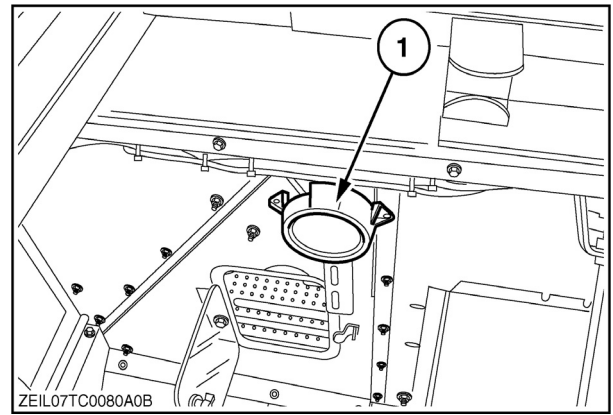

15

Grain elevator high speed kit

This kit can be used to increase the capacity of the grain elevator, especially when harvesting maize.

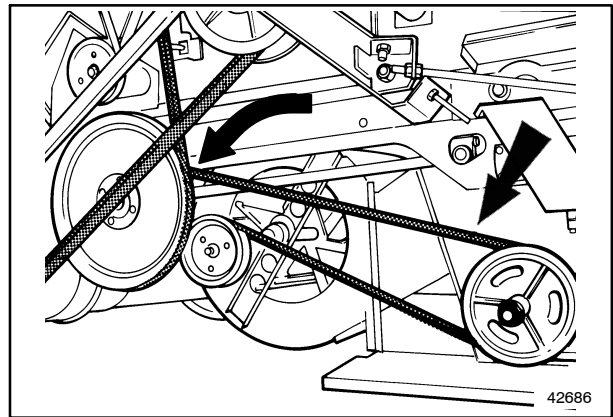

16

DELETED

STRAW HANDLING

Straw walker protection

This device can be fitted on the straw hood to warn the operator that there is an excessive straw build-up on the straw walkers. The straw activates a flap switch which sounds the horn.

This device is standard equipment when the combine is equipped with straw chopper.

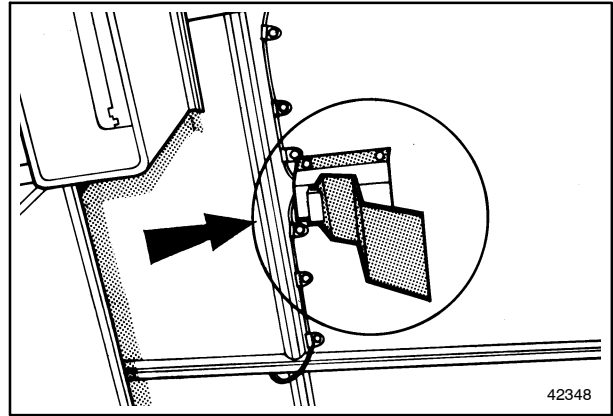

17

Straw chopper with manually adjustable deflectors

This equipment can be fitted on the machine to cut and to spread the straw if the straw has to be ploughed back into the soil.

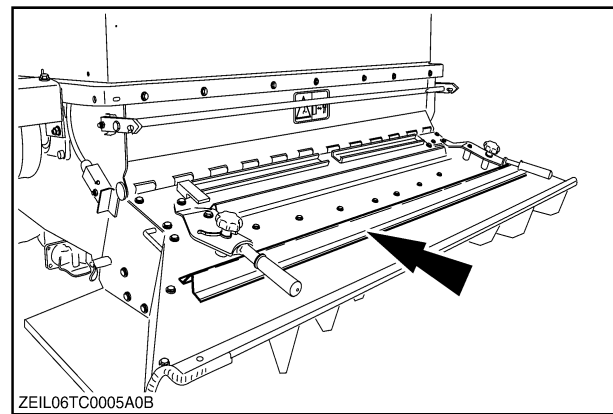

18

Remote adjustable spreader plates rebuild kit

This provides the operator with dashboard switches to reposition the chopper chute spreader plates while working and to precisely set the spread pattern behind the machine, e.g. when changing crops or in windy conditions.

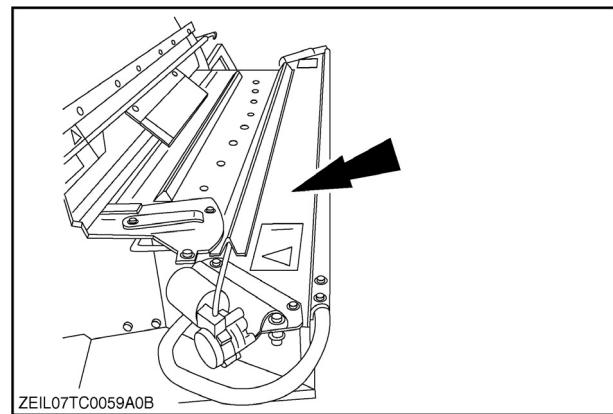

19

Straw chopper slow-down kit

This equipment should be installed for harvesting sunflower or maize to protect the knives and to prevent maize cobs pieces from being projected too violently from the chopper.

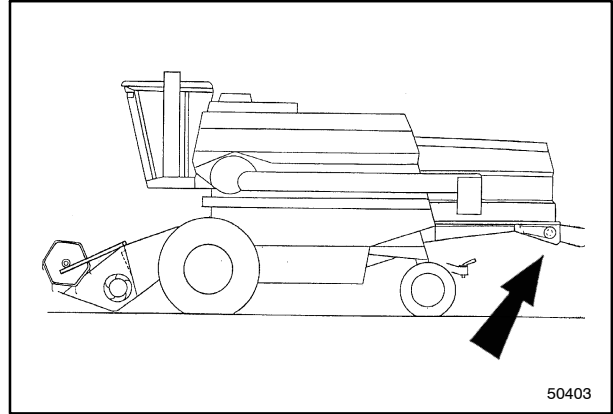

20

Straw chopper guards for maize

If the straw chopper is installed, a maize punching plate (2) should be installed in the straw hood, to avoid maize cobs from being thrown against the hood.

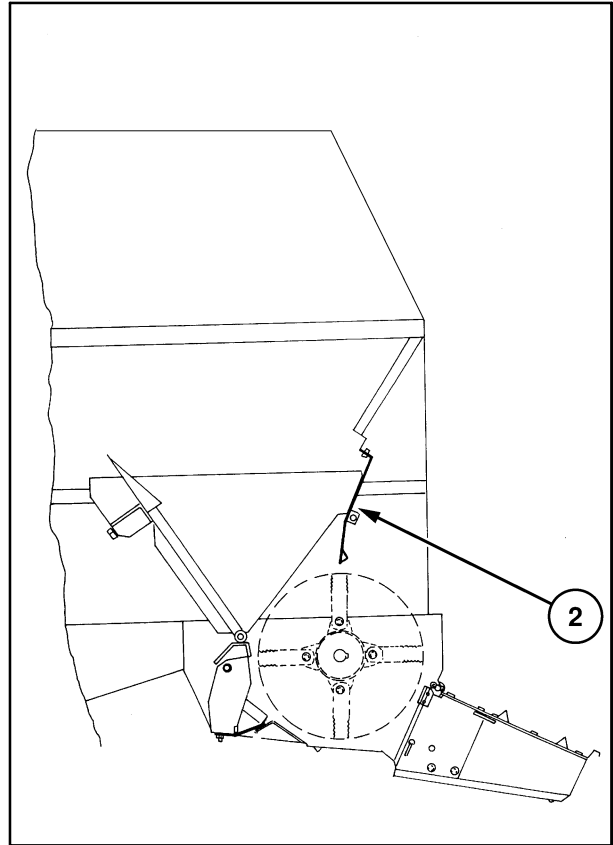

ZDA1142A 21

DELETED

Chaff spreader (TC5060 - TC5070 - TC5080)

This equipment can be fitted when the chaff from the cleaning shoe is required to be spread or to project the chaff into the straw chopper to spread or to project chaff into straw swath to increase amount of baled straw.

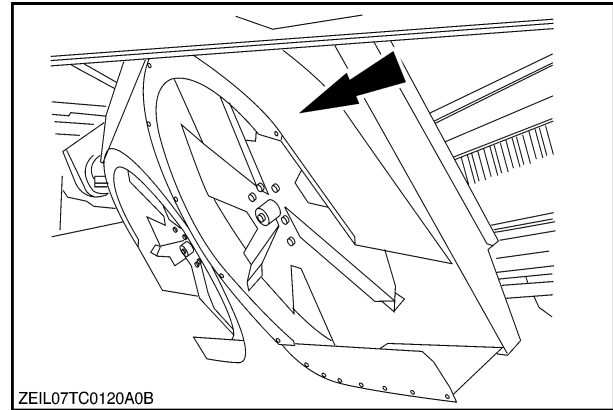

22

Straw spreader

DELETED

Swathing rake

A straw deflector can be installed in the straw hood to reduce the swath width for the following baler.

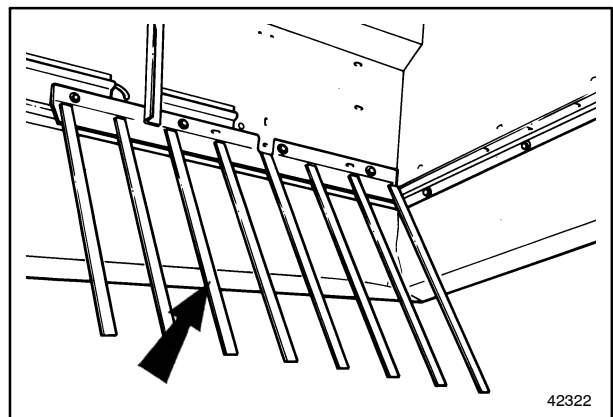

23

TRACTION AND TYRES

Ladder extension

A ladder extension is available.

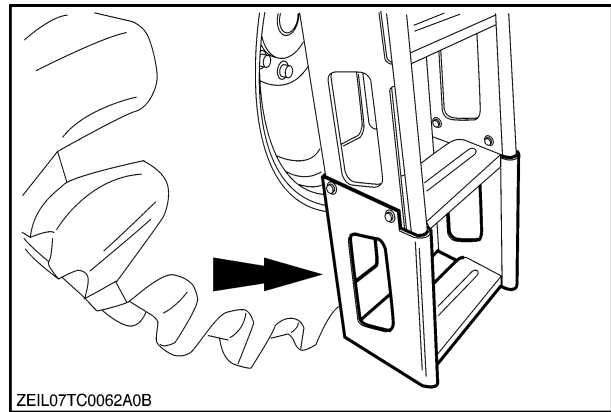

ZEL07TC0062A0B

24

Hinging ladder extension (TC5080)

A hinging ladder extension is available.

DELETED

Steering platform extension

This extension allows the use of wider traction tyres.

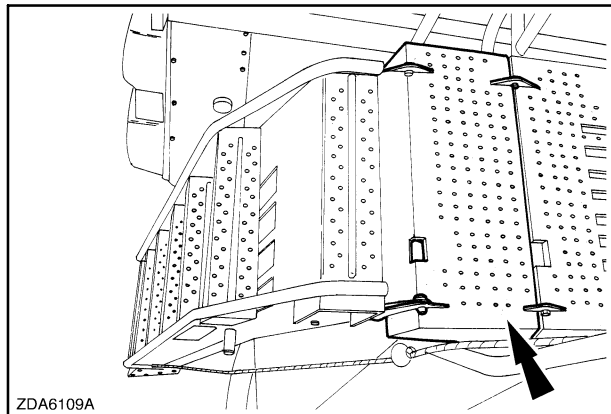

ZDA6109A

25

ENGINE

Air compressor kit (TC5070 - TC5080)

An air compressor kit can be installed to clean the engine compartment.

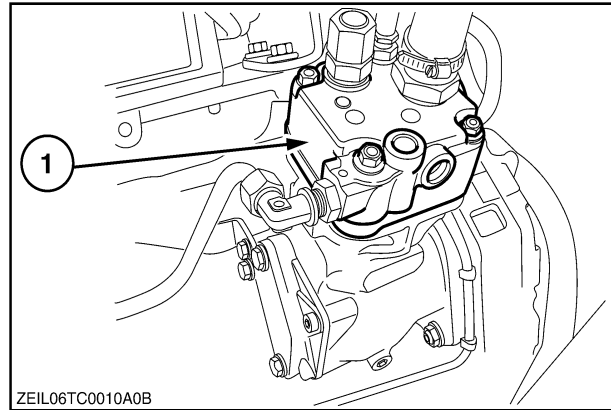

ZEIL06TC0010A0B

26

Air gun and hose (TC5070 - TC5080)

An air gun and hose is available to clean the combine.

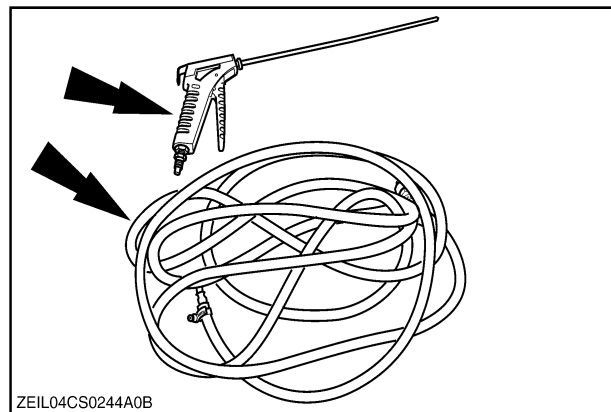

ZEIL04CS0244A0B

27

Rotary dust screen brush

This kit can be fitted to help cleaning the rotary dust screen while harvesting maize.

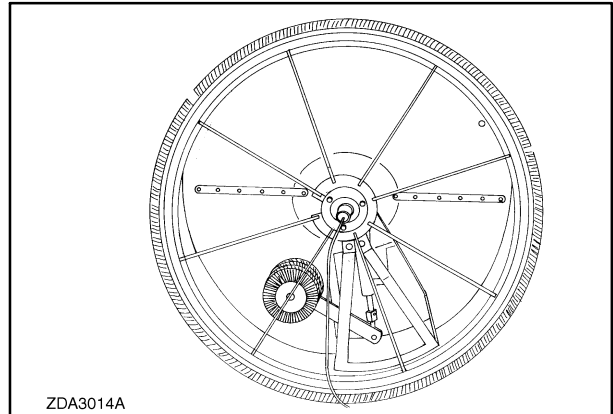

28

Grid heater

A grid heater can be installed to aid the engine in cold weather.

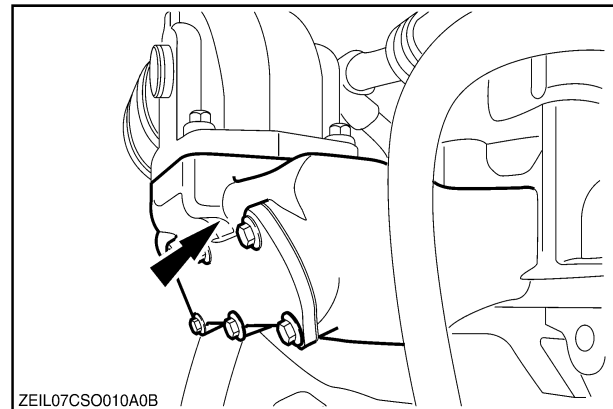

29

CAB

Sun canopy

For combine models without cab, the machine operator can be protected against the sun by a large adjustable sun canopy.

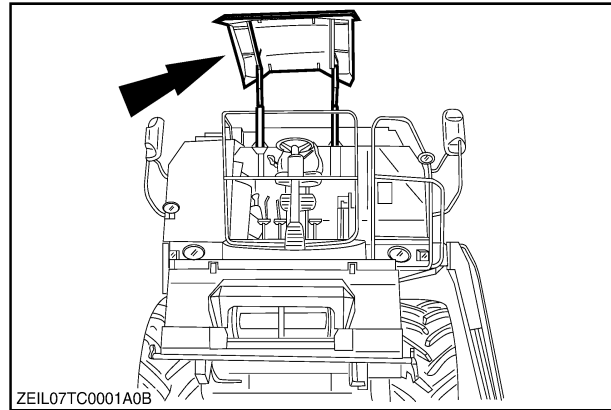

30

Additional mirrors

The additional mirrors will increase the visibility at the sides and to the rear of the machine.

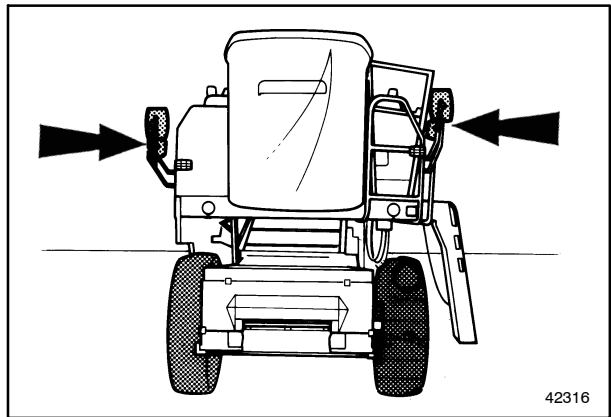

31

Screen washer kit

A screen washer kit can be installed to clean the cab windscreen.

Heating

Heating (1) can be fitted in the cab for operator comfort when operating in cold weather.

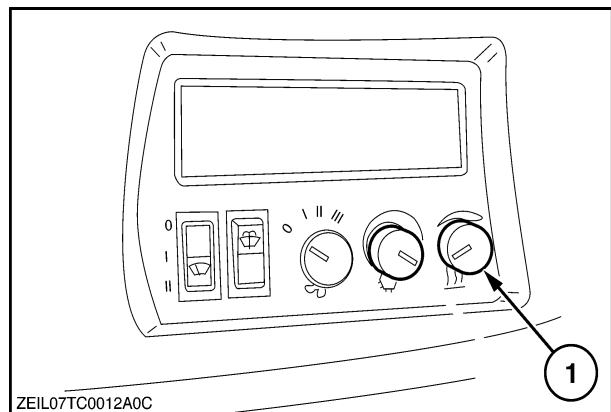

32

ELECTRICAL AND ELECTRONIC EQUIPMENT

Revolving flash light

The machine can be equipped with two revolving flash lights for driving on public roads to warn the other vehicles that it is a wide and slow-moving vehicle.

NOTE: According to local legislations, this equipment is mandatory or forbidden for driving on public roads.

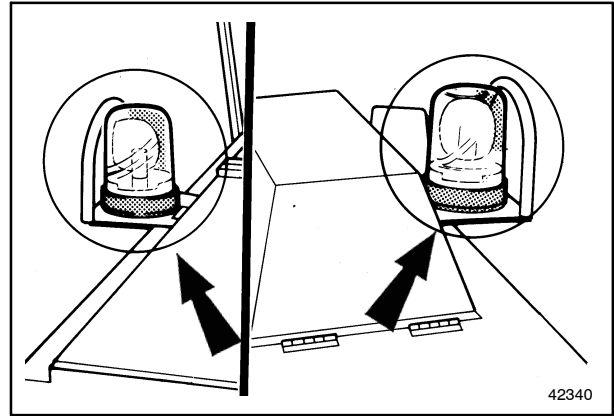

33

Adjustable light on grain tank

To perform the grain tank unloading operations at night it is possible to fit an adjustable light on the grain tank.

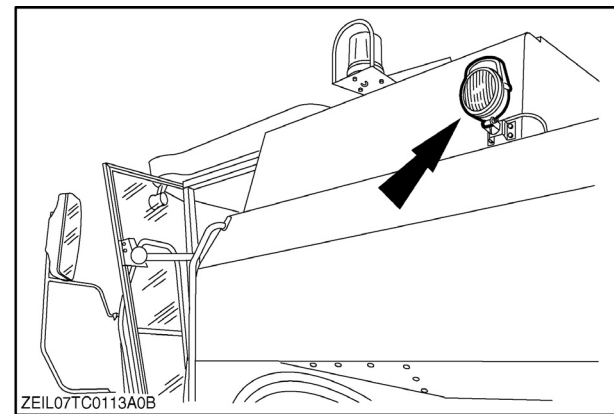

34

Portable operating light and stubble lights

Two stubble lights can be installed underneath the operator's platform for use when working at night. Two portable operating lights fitted at the straw hood gives more clarity to the rear. It can be unhooked and, among others, used to check sieve settings while using the machine at night.

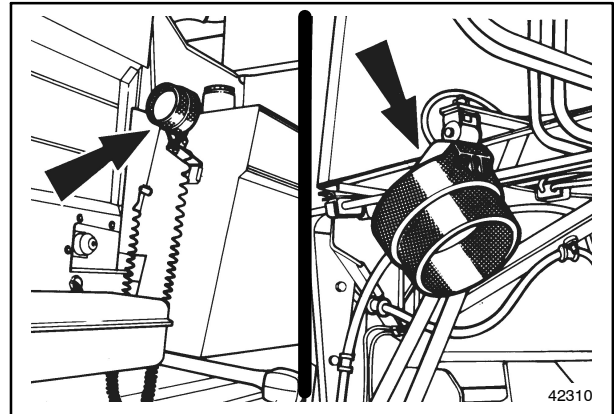

35

Performance monitor

The performance monitor indicates a possible increase or decrease in grain losses. It allows the combine to be used to its maximum capacity.

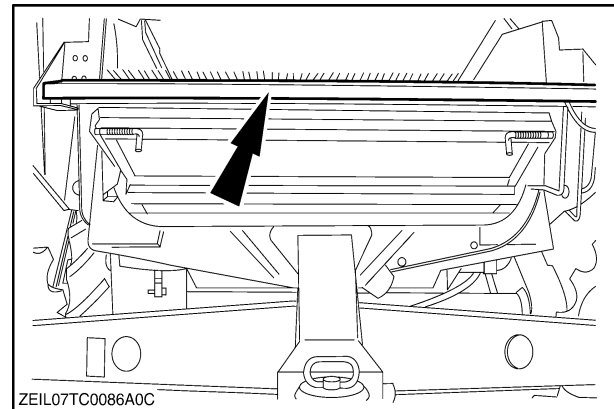

36

MISCELLANEOUS

Header trailer hitch

Two types of trailer hitches are available for towing the header trailer.

Maximum static load on this hitch and the maximum allowed header trailer weight is mentioned on a plate located on the hitch support.

• **Rotation trailer hitch**

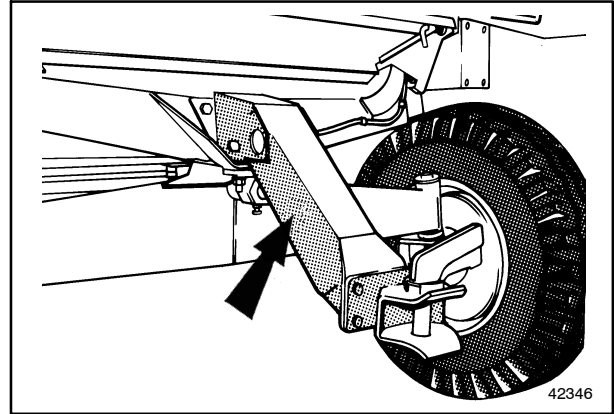

37

• **Fixed trailer hitch**

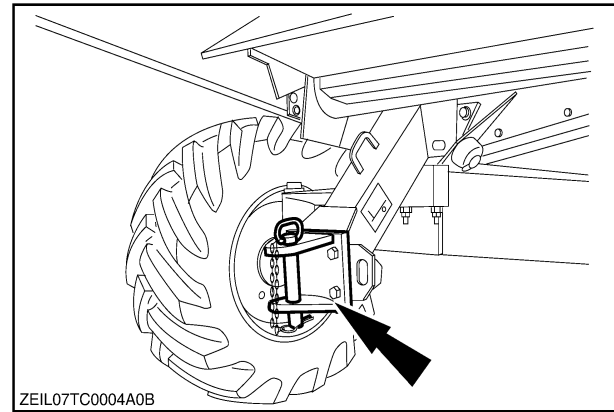

38

Wheel counterweights

Wheel weights can be fitted to the steering wheel rims.

Two sets of counterweights are available:

200 kg (441 lbs): 10 counterweights

400 kg (882 lbs): 20 counterweights

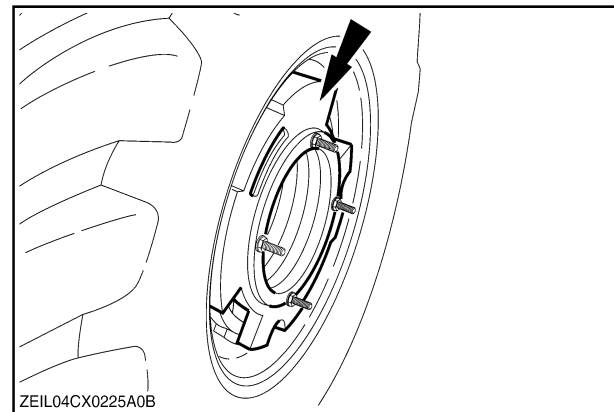

39

Signal plates

For some countries, signal plates must be installed for road transport.

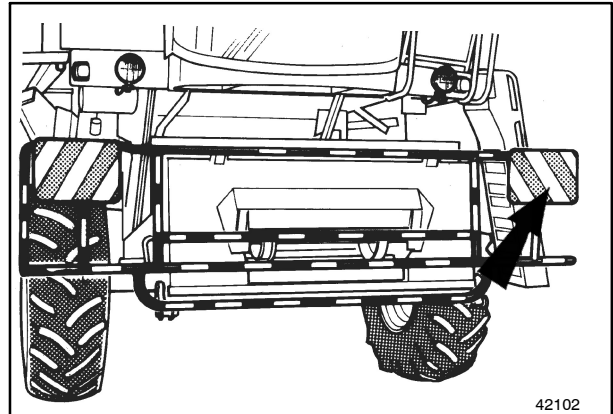

40

Signal plates for Germany

Specs Germany

Fire extinguisher

A fire extinguisher is available.

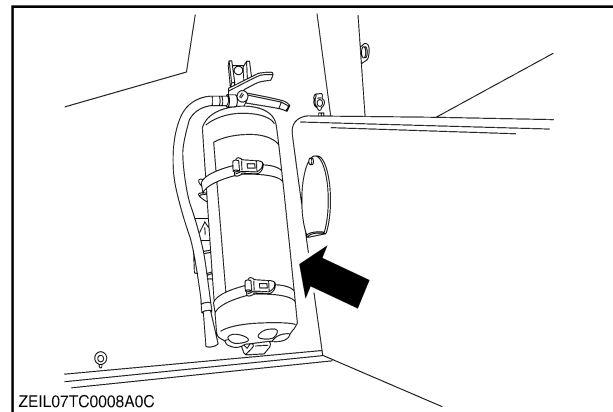

41

SECTION 7 – ACCESSORIES

SECTION 8 – SPECIFICATIONS

WHEELS AND TYRES



The tyres specified by the manufacturer are the only tyres approved. If nongenuine or replacement tyres are used, these must be identical in size and strength [PR rating for diagonal tyres or Load Capacity for radial tyres (e.g. 166 A8)] to specified tyres. The recommended tyre pressure has to be maintained at all times.

Only original NEW HOLLAND wheel rims should be used in combination with the tyre sizes indicated. Only these tyre/wheel combinations have been homologated in relation to the machine weight, width and road speed limits. The rims should be fitted in such a way that the maximum overall machine width permitted locally on public roads is adhered to.



Road travel in the 4th gear with grain in the tank is not allowed.

WHEEL NUTS TORQUE

TORQUE	MINIMUM		MAXIMUM	
	Nm	Ft.lbs	Nm	Ft.lbs
Traction wheel nuts torque	610	450	732	540
Steering wheel nuts torque (Fixed + ASA)	410	302	492	363

Tables below gives the permitted inflation pressure (bar):

Field condition:

- Speed = 10 km/h: cycling loading operations, excepting hillside applications in excess of 20% grade.
- Full grain tank + header in work position

Road condition:

- Empty grain tank

Traction tyres (pressures): road + field conditions

Steering tyres (pressures): only road conditions

“Offset”, “Track”, “Overall width” = mm

TC 5040

HEADERS										
Field					Road					
10 km/h					20 km/h		25 km/h			
Grain Header 12 ft										No header
Grain Header 13 ft										No header
Grain Header 15 ft										No header
1.4 1.5 1.5					1.0					1.0
1.1 1.1 1.1					0.8					0.9
1.3 1.3 1.4					0.6					0.7
1.0 1.0 1.0					0.6					0.6

TRACTION TYRES	Offset	Track	Overall Width
23.1 - 26 10PR SSG TD8 TL R2 (20")	-50	2512	3114
23.1 - 26 14PR (156A6) AN15 TT R1 (20")	37	2338	2943
620/75 R 26 166A8 166B DT824 TL R1W (20") (tr)	37	2338	2971
750/65 R 26 166A8 163B DT820 TL R1W (25")	-70	2552	3316

STEERING TYRES	Offset
13.0/65 - 18 12PR (138A6) SFI TL I1 (9")	-75
16.0/70 - 20 10PR Implement AS TL (14")	-95

STEERING AXLES
Fixed steering axle
Adjustable steering axle

(x) = Allowed

x	x	x	x
x	x	x	x

SECTION 8 – SPECIFICATIONS

TC 5050

HEADERS							
Field			Road				
10 km/h	20 km/h	25 km/h	30 km/h	20 km/h	25 km/h	30 km/h	
Grain Header 12 ft				No header		No header	
Grain Header 13 ft				No header		No header	
Grain Header 15 ft				No header		No header	
1.5 1.6 1.6	1.0	1.0	1.0	1.0	1.0	1.0	
1.1 1.2 1.2	0.8	0.8	0.8	0.8	0.8	0.9	
1.4 1.4 1.5	0.6	0.6	0.6	0.6	0.6	0.7	
1.0 1.0 1.0	0.6	0.6	0.6	0.6	0.6	0.6	
TRACTION TYRES							
23.1 - 26 10PR SSG TD8 TL R2 (20")							3114
23.1 - 26 14PR (166A6) AN15 TT R1 (20")							2512
620/75 R 26 166A8 166B DT824 TL R1W (20") (ft)							2943
750/65 R 26 166A8 163B DT820 TL R1W (25")							2971
750/65 R 26 166A8 163B DT820 TL R1W (25")							2552
750/65 R 26 166A8 163B DT820 TL R1W (25")							3316
STEERING TYRES							
13.0/65 - 18 12PR (138A6) SFI TL I1 (9")							Offset
16.0/70 - 20 10PR implement AS TL (14")							-75
16.0/70 - 20 10PR implement AS TL (14")							-95
STEERING AXLES							
Fixed steering axle							X X X X
Adjustable steering axle							X

SECTION 8 – SPECIFICATIONS

TC 5070

HEADERS											
Field						Road					
10 km/h						20 km/h		25 km/h		30 km/h	
Grain Header 12 ft	Grain Header 13 ft	Grain Header 15 ft				No header	No header	No header	No header	No header	No header
1.6	1.6	1.7	1.7	1.8		0.9	1.0	1.0	1.2		
1.9	1.9	2.0	2.1	2.2		0.7		0.9	1.0		
1.7	1.7	1.8	1.9	2.0		0.6		0.8	0.9		
1.4	1.4	1.5	1.6	1.7		0.6		0.6	0.7		

20 km/h		25 km/h		30 km/h	
3.3	3.2	3.7	3.6	4.1	4.0
1.0	1.0	1.0	1.0	1.1	1.1
1.0	1.0	1.0	1.0	1.2	1.1

TRACTION TYRES	Offset	Track	Overall Width
23.1 - 26 14PR (156A6) AN15 TT R1 (20")	37	2560	3165
620/75 R 26 166A8 166B DT824 TL R1W (20") (tr)	37	2560	3193
620/75 R 30 163A8 160B DT822 TL R1W (20")	-50	2734	3347
750/65 R 26 166A8 163B DT820 TL R1W (25")	-70	2774	3538

STEERING TYRES	Offset
13.0/65 - 18 12PR (138A6) SFH TL I1 (9")	-75
16.0/70 - 20 10PR Implement AS TL (14")	-95
400/70 R 20 158A8 FS24 TL I1 (14")	-95

STEERING AXLES
Fixed steering axle
Adjustable steering axle

(x) = Allowed

X	X	X
X	X	X
X	X	X

SECTION 8 – SPECIFICATIONS

TC 5080

HEADERS														
Field						Road						Overall Width		
10 km/h	20 km/h	25 km/h	30 km/h	20 km/h	25 km/h	30 km/h	20 km/h	25 km/h	30 km/h	20 km/h	25 km/h		30 km/h	
Grain Header 12 ft	1.6	1.6	1.7	1.7	1.8	1.8	1.9	0.9	1.0	1.1	1.1	1.1	1.1	3165
Grain Header 13 ft	1.9	1.9	2.0	2.1	2.2	2.2	2.4	2.0	2.1	2.2	2.4	2.6	2.6	2560
Grain Header 15 ft	1.7	1.7	1.8	1.9	2.0	2.0	2.1	1.8	1.8	1.9	2.1	2.3	2.3	2560
Grain Header 17 ft	1.3	1.3	1.4	1.5	1.5	1.6	1.7	1.4	1.4	1.5	1.6	1.7	1.8	2734
Grain Header 20 ft	1.4	1.4	1.5	1.6	1.6	1.7	1.8	1.5	1.5	1.6	1.8	2.0	2.0	3341
5 R no chopper	0.8	0.9	0.9	0.9	1.0	1.0	1.1	0.9	0.9	1.0	1.0	1.1	1.2	3538
6 R Rigid without chopper														2860
6 R Flip-up without chopper														2860
6 R Flip-up without chopper														2860
No header														3165
No header														3193
No header														3347
No header														2774
No header														3648

TRACTION TYRES	Offset	Track	Overall Width
23.1 - 26 14PR (156A6) AN15 TT R1 (20")	37	2560	3165
620/75 R 26 166A8 166B DT824 TL R1W (20") (tr)	37	2560	3193
620/75 R 30 163A8 160B DT822 TL R1W (20")	-50	2734	3347
650/75 R 32 172A8 169B DT822 TL R1W (21")	-37	2708	3341
750/65 R 26 166A8 163B DT820 TL R1W (25")	-70	2774	3538
800/65 R 32 172A8 169B DT822 TL R1W (27")	-113	2860	3648

STEERING TYRES	Offset
13.0/65 - 18 12PR (138A6) SFI TL I1 (9")	-75
16.0/70 - 20 10PR Implement AS TL (14")	-95
400/70 R 20 158A8 FS24 TL I1 (14")	-95

STEERING AXLES
Fixed steering axle
Adjustable steering axle

(x) = Allowed

X	X	X	X	X	X
X	X	X	X	X	X
X	X	X	X	X	X

SECTION 8 – SPECIFICATIONS

TECHNICAL DATA

	TC5040	TC5050	TC5060	TC5070	TC5080
HEADER					
High-Capacity Grain Header					
Cutting width	12 – 13 – 15 ft		12 – 13 – 15 – 17 ft		12 – 13 – 15 – 17 – 20 (1) ft
Cutting height	from 0 to 1600 mm				
Maize header					
Number of rows	–		5 row (Rigid)		5 – 6 row (Rigid) 6 row (Flip-up)

STRAW ELEVATOR		
Type	Fixed	Fixed / Lateral flotation
Straw elevator width	1054 mm	1314 mm
Front/Cradle width	1885 mm	
Number of chains	3	
Number of slats	16	32
Type of slats	L-slats	
Protection	spring-loaded slip clutch set at 600Nm	
Top shaft speed	376 rpm	365 rpm
Lower shaft speed	575 rpm	558 rpm
Straw elevator drive	2HC drive belt from the intermediate shaft	
Drive line	2HC belt	
Reverse system	electrical	
Stone trap	hinged	
Number of lifting cylinders	2	2 or 3
Fixed straw elevator		
– Controfloat™	–	Optional
Lateral flotation on straw elevator		
– Autofloat™	–	Standard

■ (1) former C.I.S. countries

SECTION 8 – SPECIFICATIONS

	TC5040	TC5050	TC5060	TC5070	TC5080
THRESHING DRUM					
Speed range	Variable from 430 to 1070 rpm			Variable from 417 to 1037 rpm	
Speed adjustment	Electrically controlled from the operator's platform				
Speed read-out	Display				
Drive	Variator belt from beater shaft				
Drum type	Standard drum with bars/Rice drum				
- Standard drum with bars					
Width	1040 mm		1300 mm		
Number of bars	8				
Diameter	607 mm				
- Rice drum					
Width	1040 mm		1300 mm		
Number of bars	8				
Diameter	607 mm				
Number of teeth/bar	18		22 (4 bars) 23 (remaining bars)		
Distance between teeth	56 mm				

SECTION 8 – SPECIFICATIONS

	TC5040	TC5050	TC5060	TC5070	TC5080
DRUM CONCAVE					
Width	1057 mm		1317 mm		
Adjustment possibility	14 positions, mechanical adjustment from the operator's platform				
Fine adjustments	At the suspension points, with threaded rods and nuts				
Deawning plates	4 (loose)				
Standard concave					
Wrap angle	111°				
Concave area	0.62 m ²		0.79 m ²		
Number of bars	14				
Distance between wires (centre to centre)	14 mm				
Wire diameter	3.5 mm				
Maize concave					
Wrap angle	111°				
Area	0.63 m ²		0.79 m ²		
Number of bars	10				
Distance between wires (centre to centre)	26 mm				
Wire diameter	6 mm				
Rice concave					
Wrap angle	102°				
Number of bars	4				
Number of teeth per bar	19		23		

SECTION 8 – SPECIFICATIONS

	TC5040	TC5050	TC5060	TC5070	TC5080
BEATER					
Drive	3 HB belt from the engine				
Speed	875 rpm			850 rpm	
Number of blades	4				
Width	1040 mm		1300 mm		
Grate area (without rotary separator)	0.318 m ²		0.396 m ²		
Beater concave (if applicable)					
Width	–		1317 mm		
Concave area	–		0.2 m ²		
Number of bars	–		3		
Distance between wires (centre to centre)	–		32 mm		
Wire diameter	–		6 mm		
ROTARY SEPARATOR (if applicable)					
Drive	–		1 HC belt over beater shaft		
Diameter	–		605 mm		
Width	–		1300 mm		
Number of teeth	–		10 x 7		
Speed	–		760 or 400 rpm	740 or 388 rpm	
Rotary separator concave (if applicable)					
Width	–		1317 mm		
Concave area (without rake)	–		0.66 m ²		
Concave area (with rake)	–		0.83 m ²		
Number of bars	–		12		
Distance between wires (centre to centre)	–		32 mm		
Wire diameter	–		6 mm		

SECTION 8 – SPECIFICATIONS

	TC5040	TC5050	TC5060	TC5070	TC5080
STRAW WALKERS					
Number	4		5		
Speed	220 rpm			212 rpm	
– Without rotary separator					
Number of steps	6				
Length	3780 mm				
Separation area	4 m ²		5 m ²		
– With rotary separator					
Number of steps	–		5		
Separation area	–		4.36 m ²		
Length	–		3300 mm		
CLEANING SHOE					
Type	Fixed or self-levelling				
Eccentric shaft speed	320 rpm			309 rpm	
Drive	1HC belt				
Grain pan					
Grain pan width	1001 mm		1261 mm		
Grain pan length	1926 mm				
Grain pan rake surface	0.19 m ²		0.23 m ²		
Upper shaker shoe					
Horizontal stroke	47 mm				
Throwing angle: front/ rear	27° / 27°				
Upper sieve width	996 mm		1256 mm		
Upper sieve length	1587 mm				
Upper sieve area	1.58 m ²		1.99 m ²		
Upper sieve positions	2				
Upper sieve grate sur- face	0.148 m ²		0.187 m ²		
Graepel area	0.153 m ²		0.191 m ²		
Lower shaker shoe					
Horizontal stroke	33 mm				
Throwing angle	15°				
Lower sieve length	1359 mm				
Lower sieve width	996 mm		1256 mm		
Lower sieve area	1.35 m ²		1.71 m ²		
Lower sieve positions	1				
Total sieve area under wind control	3.27 m ²		4.12 m ²		

SECTION 8 – SPECIFICATIONS

	TC5040	TC5050	TC5060	TC5070	TC5080
CLEANING FAN					
Number of blades	6				
Speed range	Variable from 350 to 1000 rpm			Variable from 340 to 970 rpm	
Speed adjustment	Manual or electrical	Electrical			

RETURNS SYSTEM					
Type	Bottom cross auger – Returns elevator to drum				
Drive	Chain				
Speed	368 rpm			357 rpm	

GRAIN TANK, UNLOAD					
Grain tank capacity	4000 litres	5200 litres	6000 litres		
Unloading drive	1 HB belt and chain				
Unloading tube length	3.85 m				
Unloading rate	72 litres/sec				

GRAIN TRANSPORT					
Type	Grain elevator and filling auger				
Drive	1 HB belt over eccentric shaft				
Speed	368 rpm			357 rpm	

STRAW CHOPPER					
Drive	2 HB belt – straw chopper clutch – 2HB belt				
Clutch speed	2420 rpm			2350 rpm	
Rotor speed	2465 or 3500 rpm			2390 or 3400 rpm	
Distance between knives	25 mm				

CHAFF SPREADER					
Drive	–		1 HB belt		
Rotor speed	–		580 rpm		

SECTION 8 – SPECIFICATIONS

	TC5040	TC5050	TC5060	TC5070	TC5080
ENGINE					
Type	New Holland (**)				
Gross power @ 2100 rpm (ISO TR14396)	125 kW (170CV)		152 kW (207CV)	177 kW (240CV)	
Maximum power @ 2000 rpm	129 kW (175CV)		164 kW (223CV)	178 kW (242CV)	
Injection system	Rotary injection pump			Common rail	
Governor	Mechanically			Electronically	
Rated speed	2100 rpm				
Low idle speed	1300 rpm				
High idle speed	2205 rpm			2100 rpm	
Displacement	6700 cc				
Bore	104 mm				
Stroke	132 mm				
Water pump speed	4084 rpm				
Ventilator speed	1382 rpm			1530 rpm	
Crankcase oil capacity (with oil filter)	16 litres				
Battery	2 x 12 V – 92 Ah				
Starter motor	12 V – 3.0 kW				
Alternator type	120 A (12V)				
Alternator speed	6409 rpm				
Rotary screen speed	226 rpm				
AC compressor speed	2943 rpm			3036 rpm	
Fuel tank	300 litres			400 litres	

(**) developed by CNH Engine Corporation

SECTION 8 – SPECIFICATIONS

	TC5040	TC5050	TC5060	TC5070	TC5080
--	---------------	---------------	---------------	---------------	---------------

PNEUMATIC SYSTEM					
Air compressor speed	-			2160 rpm	
Air reservoir	-			60 litres	

HYDRAULIC SYSTEM					
Pump capacity	16 + 5.5 cc/rev			Fixed 16 + 5.5 cc/rev Lateral float 16 + 5.5 + 2 cc/rev	
Maximum pressure	210 bar				
Steering valve					
- Type	OSPC 100				
- Maximum pressure	100 bar				
- Shock valve setting	150 bar				

HYDROSTATIC SYSTEM					
Pump flow rate	-	75 cc/rev	-	100 cc/rev	
Motor capacity	-	75 cc	-	100 cc	
Maximum pressure	-	420 bar	-	320 bar	420 bar
Speed pump	-	3000 rpm	-	2620 rpm	

Reservoir capacity	20 litres	38 litres	20 litres	38 litres	
--------------------	-----------	-----------	-----------	-----------	--

CAB					
	Optional	Standard			
Operator's seat	Standard			Standard / Air suspended	
Instructional seat	-	Optional	-	Optional	
Remote controls	-	Optional	-	Optional	
Air conditioning	Optional	Standard			
Screen washer kit	Optional				
Heating	Optional				

SECTION 8 – SPECIFICATIONS

	TC5040	TC5050	TC5060	TC5070	TC5080
TRACTION					
Transmission	Mechanical	Hydrostatic	Mechanical	Hydrostatic	
Number of gears	4 speed			3 speed	
Gearbox oil capacity	15 litres			19 litres	
Differential	10/52			16/71	
Forward ground speed					
Tyres	18.4 x 30		23.1 x 26	620/75R26	
- 1 st gear (full load)	1.0 – 2.54 km/h	0 – 2.88 km/h	1.01 – 2.58 km/h	0 – 5.7 km/h	
- 2 nd gear (full load)	2.16 – 5.53 km/h	0 – 6.26 km/h	2.19 – 5.61 km/h	0 – 10.4 km/h	
- 3 rd gear (full load)	3.94 – 10.16 km/h	0 – 11.38 km/h	3.99 – 10.2 km/h	Maximum permissible ground speed	
- 4 th gear (full load)	Maximum permissible ground speed			-	
Steering axle	fixed or adjustable				
FINAL DRIVE					
Ratio	10/75				
Mud seal	Optional				
Oil capacity	5.5 litres				
WEIGHT					
(-)	7600 kg		8520 kg		8720 kg

(-): configuration

- Without rotary separator
- Without straw chopper
- Empty fuel tank
- Empty grain tank

DIMENSIONS

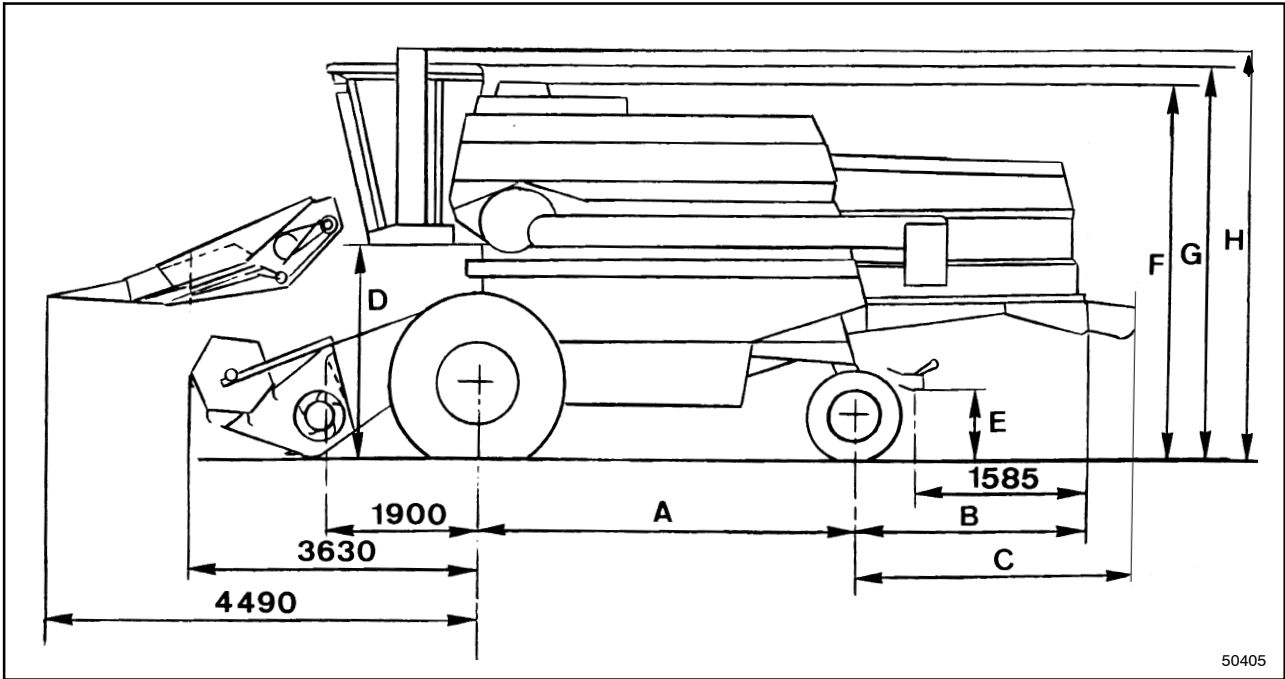

1

The dimensions of the drawing above are expressed in mm.

Steering axle dimensions	A	B	C
fixed	3.43 m	2.32 m	2.80 m
adjustable	3.41 m	2.33 m	2.81 m

TRACTION TYRES	D	E	F	G	H
23.1 x 26 – 14 PR-R1	2.00 m	0.51 m	3.63 m	3.86 m	3.94 m
620/75R26 – 166A8-DT824	1.99 m	0.50 m	3.62 m	3.85 m	3.93 m
23.1 x 26 – 10 PR-R20-SSG-TD8	2.00 m	0.51 m	3.63 m	3.86 m	3.94 m
620/75R30 – 163A8-DT822	2.05 m	0.56 m	3.68 m	3.91 m	3.99 m
750/65R26 – 166A8-DT820	2.00 m	0.51 m	3.63 m	3.85 m	3.94 m
650/75R32 – 172A8-DT822	2.12 m	0.56 m	3.75 m	3.98 m	4.00 m
800/65R32 – 172A8-DT822	2.12 m	0.56 m	3.75 m	3.98 m	4.00 m

GRAIN TANK UNLOAD TUBE POSITION

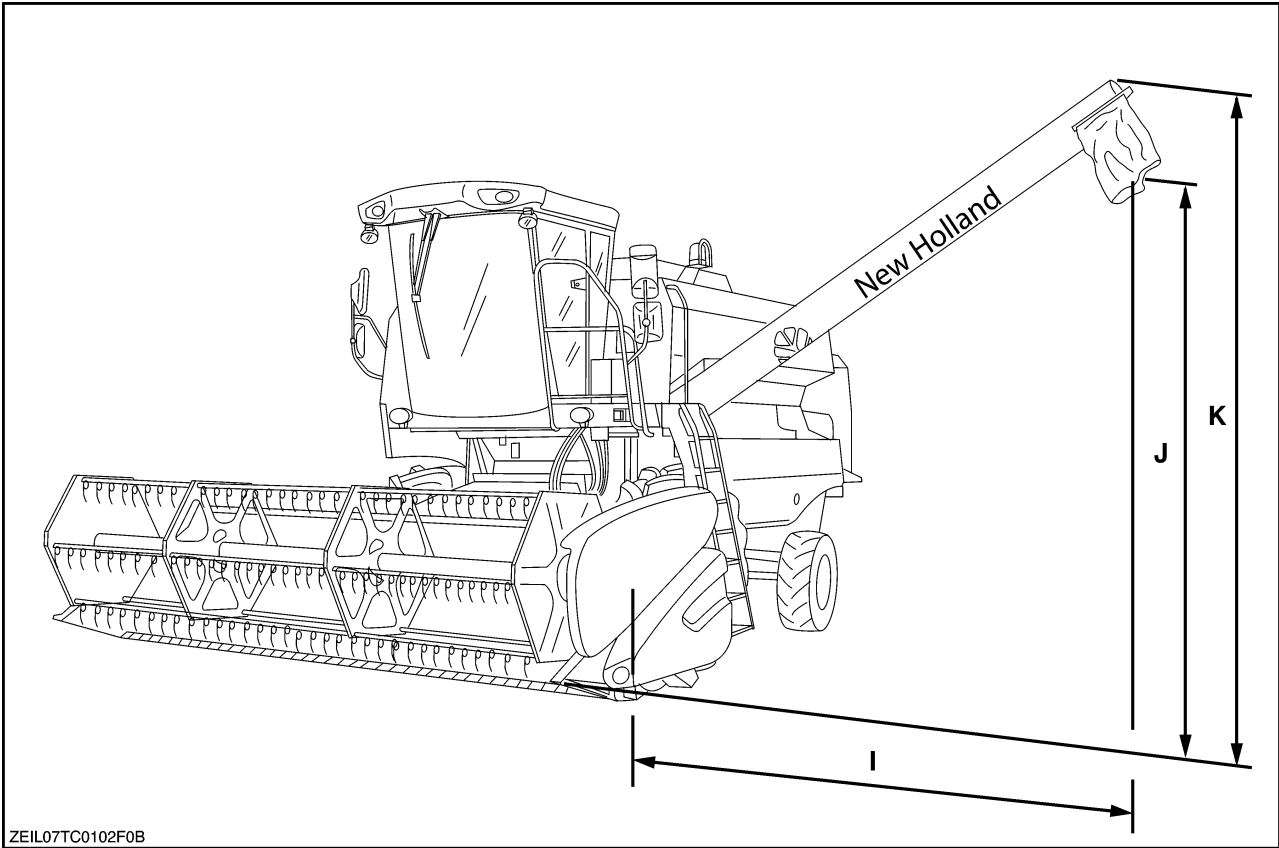

ZEIL07TC0102F0B

SECTION 8 – SPECIFICATIONS

Dimensions

a) Grain header

Header width	Dimension I
12 ft	2.24 m
13 ft	2.09 m
15 ft	1.79 m
17 ft	1.49 m
20 ft	1.04 m

b) Maize header

Header width	Dimension I
5 row Row distance 70 – 80 cm	2.3 m
6 row (rigid) Row distance: 70 – 75 cm Row distance: 75 – 80 cm	2.02 m 1.9 m
6 row (flip-up) Row distance: 70 – 75 cm Row distance: 75 – 80 cm	2.03 m 1.91 m

Traction tyres	Dimension K	Dimension J
23.1 x 26 – 14 PR-R1-DT	4.49 m	3.94 m
620/75R26 – 166A8-DT820 (SQ)	4.48 m	3.94 m
23.1 x 26 – 10 PR-R20-SSG-TD8	4.44 m	3.90 m
23.1 x 30 – 14 PR-R1-DT	4.54 m	3.99 m
620/75R30 – 163A8-DT820	4.54 m	3.99 m
750/65R26 – 165A8-DTR	4.46 m	3.92 m
650/75R32 – 167A8-DT820	4.64 m	4.07 m
800/65R32 – 167A8-STR	4.64 m	4.07 m

SECTION 9 – 1ST 50 HOUR SERVICE SHEETS

CHECK AND ADJUST, AS REQUIRED (CUSTOMER COPY)

- | | |
|--|--|
| 1. Perform the 50 hour grease zerk service ... <input type="checkbox"/> | 12. Lubricate all chains <input type="checkbox"/> |
| 2. Check wheel nut and torques <input type="checkbox"/> | 13. Check coolant level (shunt tank) <input type="checkbox"/> |
| 3. Check steering ball joints <input type="checkbox"/> | 14. Check brake fluid level <input type="checkbox"/> |
| 4. Check and clean air conditioning condenser <input type="checkbox"/> | 15. Clean cab air filter <input type="checkbox"/> |
| 5. Check air conditioning filter-drier <input type="checkbox"/> | 16. Check fuel level <input type="checkbox"/> |
| 6. Check tyre pressure <input type="checkbox"/> | 17. Clean stone trap <input type="checkbox"/> |
| 7. Check drum concave setting <input type="checkbox"/> | 18. Drain water from fuel system prefilter/
water separator <input type="checkbox"/> |
| 8. Check electrolyte level in batteries <input type="checkbox"/> | 19. Check the tension of the grain elevator
chain and returns elevator chain <input type="checkbox"/> |
| 9. Check engine oil level <input type="checkbox"/> | 20. Check traction gearbox oil level <input type="checkbox"/> |
| 10. Check hydraulic/hydrostatic oil level <input type="checkbox"/> | 21. Check final drive gearbox oil level <input type="checkbox"/> |
| 11. Check all chain and belt tensions <input type="checkbox"/> | |

THE INSPECTION HAS BEEN MADE

COMBINE MODEL NO: **COMBINE SERIAL NO:**

SIGNATURE OWNER, DATE: **SIGNATURE DEALER, DATE:**

CHECK AND ADJUST, AS REQUIRED (DEALER COPY)

- | | |
|--|--|
| 1. Perform the 50 hour grease zerk service ... <input type="checkbox"/> | 12. Lubricate all chains <input type="checkbox"/> |
| 2. Check wheel nut and torques <input type="checkbox"/> | 13. Check coolant level (shunt tank) <input type="checkbox"/> |
| 3. Check steering ball joints <input type="checkbox"/> | 14. Check brake fluid level <input type="checkbox"/> |
| 4. Check and clean air conditioning condenser <input type="checkbox"/> | 15. Clean cab air filter <input type="checkbox"/> |
| 5. Check air conditioning filter-drier <input type="checkbox"/> | 16. Check fuel level <input type="checkbox"/> |
| 6. Check tyre pressure <input type="checkbox"/> | 17. Clean stone trap <input type="checkbox"/> |
| 7. Check drum concave setting <input type="checkbox"/> | 18. Drain water from fuel system prefilter/
water separator <input type="checkbox"/> |
| 8. Check electrolyte level in batteries <input type="checkbox"/> | 19. Check the tension of the grain elevator
chain and returns elevator chain <input type="checkbox"/> |
| 9. Check engine oil level <input type="checkbox"/> | 20. Check traction gearbox oil level <input type="checkbox"/> |
| 10. Check hydraulic/hydrostatic oil level <input type="checkbox"/> | 21. Check final drive gearbox oil level <input type="checkbox"/> |
| 11. Check all chain and belt tensions <input type="checkbox"/> | |

THE INSPECTION HAS BEEN MADE

COMBINE MODEL NO: **COMBINE SERIAL NO:**

SIGNATURE OWNER, DATE: **SIGNATURE DEALER, DATE:**

SECTION 10 – INDEX

A

Air reservoir specification	4-84
A/C system	4-81
Access to machine components	1-30
Access to the drum and to the concave	3-52
Access to the grain pan	3-50
Access to the straw chopper rotor	3-80
Accumulator	4-29
Additional mirrors	7-15
Adjustable light on grain tank	7-16
Adjustable steering axle (if installed)	4-70
Adjustment for harvesting maize	3-37
Adjustment of the dimmed lights	1-39
Adjustment values	3-51
Air compressor kit	7-13
Air compressor	4-83
Air conditioning compressor drive belt	4-56
Air gun and hose	7-13
Air intake system	4-24
Airborne noise emission	1-15
Alarm control module	2-14
Alternator	4-79
Alternator, water pump (and air conditioning compressor) drive belt	4-55
Anti-dust plate	3-50
Anti-wrap shields	7-2
Area counter	2-35
Attaching a trailer	1-36
Attaching the header to the combine	3-19
Attachment compatibility	1-40
Audible alarm	2-40
Auto-diagnostics	3-35
Autofloat™ operation	3-28
Automatic ground speed calibration	2-32
Automatic shut-off	2-44

B

Batteries	4-77
Battery charge warning light	4-79
Battery warning	1-13
Beater pins	7-4
Before driving the combine	3-1
Biodiesel fuel	1-12
Bleeding the fuel system	4-21
Brake fluid level	4-35
Brake system	4-35
Brakes	4-62

C

Cab	7-15
Cab air filter	4-80
Cab and controls	2-1
Cab door	2-1
Cab roof controls	2-17
Cab/climate control	4-80
Cereal threshing rebuild kit	7-5
Chaff spreader	3-84, 7-11
Chaff spreader drive belt	4-47
Chain tension	4-57
Chains	4-34
Chopping maize	3-82
Chopping position	3-77
Clean grain, grain tank and unloading	7-8
Cleaning	3-6
Cleaning fan	3-67
Cleaning fan bottom shield	7-7
Cleaning fan variator drive belt	4-51
Cleaning shoe drive belt	4-44
Cleaning system	7-6
Clutch fluid level	4-36
Clutch pedal	2-1
Combine functions	3-4

SECTION 10 – INDEX

Combine performance check	3-15
Compensation operation	3-27
Concave clearance	3-54
Concave clearance mechanical adjustment	3-55
Concave position for harvesting maize	3-55
Condenser	4-81
Coolant change	4-16
Coolant level	4-16
Coolant specification	4-18
Coolant system capacity	4-18
Counter knives	3-81
Cylinder safety latch on straw elevator	1-25

D

Daily start-up procedure	3-2
De-awning plates	3-56, 7-4
De-awning slats	7-3
De-awning slats (accessory)	3-57
Detaching the header from the combine	3-21
Diesel fuel	1-12
Dimensions	8-16
Drive chains and belts (left side)	4-38
Drive chains and belts (right side)	4-48
Driving the combine	3-3
Drum and concave	3-51
Drum and concave type use	3-57
Drum blockage	3-53
Drum concave	3-43
Drum speed	3-51
Drum variator belt	4-49

E

Electrical and electronic equipment	7-16
Electrical system	4-72
Electromagnetic compatibility	1-15
Elevator chains	4-58
Elevator slip clutch	4-59
Emergency exit	2-1

End-Of-Season service	6-1
Engine	1-2, 1-11, 4-13, 5-10, 7-13
Engine – Error messages	5-19, 4-56, 4-16, 2-42, 4-14
Evaporator	4-82
Extended dividers	7-7

F

Fluid specification	4-36
Fuel storage	4-22
Fan speed adjustment	3-67
Feeding	3-5, 7-1
Feeding area	5-2
Filter-drier	4-82
Final drive gearboxes	4-33
Fire extinguisher	1-29
Fixed steering axle	4-68
Fixed trailer hitch	7-18
Fluid change	4-35
Foot brake "bedding-in" procedure	4-63
Foot brakes	4-63
Fuel filter	4-20
Fuel prefilter / water separator	4-19
Fuel specification	4-22
Fuel tank drain plug	4-19
Full header width	2-30
Fundamentals of adjustment	3-51
Fuses and relays	4-72

G

General problems	5-7
General recommendations	1-4
Grain cross auger and elevator drive belt	4-46
Grain elevator	4-58
Grain elevator high speed kit	7-8
Grain header illumination kit	7-1
Grain pan dividers	3-66
Grain pan/upper sieve distribution	3-16

SECTION 10 – INDEX

Grain returns cross auger and elevator drive chain	4-46
Grain sample	3-72
Grain storage and unloading	3-9
Grain storage/unloading	3-71
Grain tank bottom auger drive chain	4-50
Grain tank cover	3-72
Grain tank filling auger drive chain	4-51
Grain tank filling system	3-71
Grain tank level sensor	3-74, 7-8
Grain tank sample	3-15
Grain tank unload tube position	8-17
Grain tank unloading auger	3-73
Grass seed equipment	7-7
Grease fittings and intervals	4-1
Grease specification	4-1
Grid heater	7-14
Ground level calibration	3-32
Ground level calibration through the Autofloat™ sensors	3-34
Ground speed constant adjustment	2-31
Ground speed vari-drive belts	4-42

H

Header	3-19
Header additional safety latch	1-25
Header and straw elevator reversing system	3-23
Header compensation gauge	3-24
Header drive belt	4-39
Header height control	3-25
Header height control – Error messages	5-16
Header height control calibration	3-31
Header levelling	3-22
Heating	7-15
High-Capacity Grain Header	1-2
How to obtain an idea on loss level	3-18
Hydraulic and hydrostatic system	4-26

Hydraulic oil specifications	4-29
Hydraulic pump drive belt	4-56
Hydraulic remote control valves	4-30
Hydrostatic control cable adjustment	4-30
Hydrostatic pump drive belt	4-44
Hydrostatic system	4-30

I

Installation	3-46
Intended use	1-1

K

Kill stall	3-15
------------	------

L

Ladder extension	7-12
Left-hand side components	2-23
Legal obligations	1-14
Lifting the combine	1-37
Losses	3-16
Lower sieve	3-63
Lubrication schedule	4-37

M

Machine error messages	2-41
Machine safety	1-3
Machine settings	2-29
Main engaging drive belt	4-45
Maintenance	1-9
Maintenance schedule	4-85
Maize Header	1-2
Maize threshing rebuild kit	7-5
Manual adjustable deflector plates	3-78
Manual clearing of the header and straw elevator blockage	3-24
Maximum cylinder pressure calibration	3-33
Metric/ imperial setting	2-34
Miscellaneous	7-18

SECTION 10 – INDEX

Multi-function handle 2-15

O

Oil and filter change 4-14, 4-27
 Oil capacity 4-29, 4-31, 4-33
 Oil change 4-31, 4-33
 Oil level 4-13, 4-26, 4-31, 4-33
 Oil reservoir 4-26
 Oil specifications 4-31, 4-33
 Operating the attachments 1-8
 Operating the combine 1-7
 Operation modes 3-26
 Ordering parts and/or accessories 6-3
 Other components 2-25

P

Parking brake 4-64
 Performance indicators 3-15
 Performance monitor 2-26, 7-17
 Personal safety 1-3
 Pivot points 4-34
 Portable operating light and stubble lights 7-17
 Positioning, removal, installation 3-63, 3-65
 Precautionary statements 1-3
 Pre-season service 6-4
 Product identification 1-1
 Prohibited usage 1-1
 Protective devices 1-25

Q

Quick release coupler 7-1

R

Remote adjustable deflector plates 3-78
 Remote adjustable spreader plates rebuild kit 7-9
 Return sample 3-16

Returns 3-70
 Returns elevator 4-59
 Returns system 3-69
 Returns top auger drive chain 4-51
 Revolving flash light 7-16
 Rice kit for fixed straw elevator 7-2
 Rice kit for lateral float straw elevator 7-2
 Rice threshing rebuild kit 7-5
 Right-hand module 2-6
 Right-hand side components 2-22
 Rotary dust screen and cooling system 4-23
 Rotary dust screen brush 7-14
 Rotary dust screen drive belt 4-55
 Rotary dust screen intermediate shaft drive belt 4-55
 Rotary separator 3-59
 Rotary separator drive belt 4-53
 Rotary separator speed 3-59
 Rotary separator wear plates 3-59
 Rotation trailer hitch 7-18
 Round hole sieves 7-6

S

Safety decals 1-16
 Safety guard for straw elevator 1-26
 Safety guards 1-28
 Safety precautions 1-3
 Safety requirements 1-14
 Screen washer kit 7-15
 Self-levelling cleaning system 3-9, 3-66
 Self-levelling system calibration 4-60
 Separation 3-6
 Shaft speed alarm indications 2-44
 Shaft speed calibration 2-43
 Shaft speed sensor failure 2-44
 Sieve opening adjustment 3-63, 3-64
 Sieve types (available) 3-62
 Sieve-levelling system blockage 4-61
 Signal plates 1-27, 7-19

SECTION 10 – INDEX

Software version	2-39
Specifications	8-1
Starting the engine	3-2
Starting up the combine	1-5
Steering axle	4-67
Steering column and control pedals	2-5
Steering platform extension	7-12
Stone trap	3-49
Stopping the combine	1-8
Stopping the engine	3-3
Storing partial area	2-38
Straw chopper	5-14
Straw chopper availability	2-33
Straw chopper clutch	3-79
Straw chopper front drive belt	4-46
Straw chopper guards for maize	7-10
Straw chopper operation	3-79
Straw chopper rear drive belt	4-46
Straw chopper rotor knives	3-80
Straw chopper slow-down kit	7-10
Straw chopper spreader chute	1-28
Straw chopper with manually adjustable deflectors	7-9
Straw elevator	3-36, 3-38, 4-57, 7-2
Straw elevator additional support	1-25
Straw elevator adjustment	3-36
Straw elevator and header engaging drive belt	4-39
Straw elevator slip clutch	4-57
Straw handling	3-75, 7-9
Straw spreader	7-11
Straw walker drive belt	4-52
Straw walker protection	7-9
Straw walker vertical cover plates	7-3
Straw walkers	3-61
Straw-retaining curtain	3-60
Stubble height indicator	3-24
Stubble height operation	3-29
Summary of the machine settings for different crops	3-10
Swath-forming position	3-75

Swathing rake	3-76, 7-11
---------------	------------

T

Technical data	8-7
Third header lift cylinder	7-2
Threaded rods	4-34
Threshing	3-6
Threshing and separation	7-3
Threshing area	5-2
Threshing, separation and cleaning	5-4
Tie downs for shipping	1-38
To change from grain to maize	3-14
Toe-in adjustment	4-67
Towing the combine	1-36
Traction and tyres	7-12
Traction clutch	4-66
Traction gearbox	4-31
Transport operation	3-26
Transport position	3-75
Travelling on public roads	1-6

U

Unloading system engaging belt	4-41
Unloading tube	3-73
Upper sieve	3-64
Upper sieve HC 1-5/8"	7-6

V

Vibration level information	1-15
-----------------------------	------

W

Wheel chock	1-26
Wheel counterweights	7-18
Wheel nuts torque	8-1
Wheels and tyres	8-1



AFTER SALES – Technical Information
Print no. **87640842** – 1st Edition – 09 – 2007

PRINTED IN FRANCE

COPYRIGHT BY CNH BELGIUM N.V.

All rights reserved.
No entire or partial reproduction is allowed.

New Holland policy is intended to improve continuously its products and reserves the right to change prices, technical specifications or equipment in any moment without notice.

All data in this publication are subject to production changes. Dimensions and weights are indicative. Illustrations do not necessarily represent the products in their standard configuration. For further accurate information on products, turn to your New Holland dealer.

LUBRICANTS TO BE USED

A new line of specially formulated Ambra–NH lubricants, based on own Engineering specifications, is available from your NEW HOLLAND dealer. For this combine we recommend:

ITEM	Servicing intervals	Amount unit	NEW HOLLAND brand name	NEW HOLLAND specification	Lubricant grade	International specification
Grease zerks	10 hours 50 hours 100 hours	– – –	AMBRA GR9 or AMBRA GR75MD	NH710A or NH720A		NLGI 2 NLGI 2
Traction gearbox	Check every 50 hours. Change – after the first 100 hours – every 600 hours or annually	15 litres	AMBRA HYPOIDE 90	NH520A	SAE 80W90	API GL5, MIL–L 2105D
Final drives	Check every 50 hours. Change – after the first 100 hours – every 600 hours or annually	5.5 litres	AMBRA HYPOIDE 90	NH520A	SAE 80W90	API GL5, MIL–L 2105D
Engine (sump with filter)	Check daily. Change: – every 600 hours	16 litres	AMBRA MASTER GOLD HSP	NH330H	SAE15W40	API CH–4 ACEA E3/E5
Chains	Daily					
Threaded rods	every 300 hours	–	AMBRA HYPOIDE 90	NH520A	SAE 80W90	API GL5, MIL–L 2105D
Pivot points	every 300 hours					
Brake system	Check every 50 hours. Change every two years.	0.325 litres (reservoir)	AMBRA SYNTFLUID 4	NH800A	SAE J 1703	NHTSA 116–DOT 4, ISO 4925
Clutch system	Check every 50 hours. Change every two years.	(reservoir)	AMBRA SYNTFLUID 4	NH800A	SAE J 1703	NHTSA 116–DOT 4, ISO 4925
Hydraulic system (oil + filter)	Check daily. Change: – after the first 100 hours (filter only) – every 600 hours or annually	TC5040 TC5060 20 litres	AMBRA HYDRO-SYSTEM 46	NH646 NH646BS NH646BV	HV 46	DIN 51524 Part 2 ISO VG 46
Hydraulic and hydrostatic system (oil + filter)	Check daily. Change: – after the first 100 hours (filter only) – every 600 hours or annually	TC5050 TC5070 TC5080 38 litres	AMBRA HYDRO-SYSTEM 46	NH646 NH646BS NH646BV	HV 46	DIN 51524 Part 2 ISO VG 46
Cooling system	Check daily. Change: – every two years	38 litres	50% AGRIFLU 50% WATER	NH900A	–	–

DELETED





Your success - Our specialty

Printed in France

© 2007 CNH Global N.V.