

927000 Series 6, 7, 8 And 10 H.P. Riding Mowers

Model 927001 (RM728) 7 H.P.
Tecumseh recoil w/28'' pan

Model 927002 (RM626) 6 H.P.
Tecumseh recoil w/26'' pan

Model 927003 (RM626) 6 H.P.
Tecumseh recoil w/26'' pan

Model 927004 (RM830e) 8 H.P.
Briggs elec. start w/30'' pan

Model 927005 (RM832) 8 H.P.
Tecumseh recoil w/32'' pan

Model 927006 (RM832e) 8 H.P.
Briggs elec. start w/32'' pan

Model 927007 (RM1032) 10 H.P.
Tecumseh recoil w/32'' pan

Model 927008 (RM1032e) 10 H.P.
Tecumseh elec. start w/32'' pan

Model 927009 (RM828) 8 H.P.
Tecumseh recoil w/28'' pan

Model 927010 (RM830) 8 H.P.
Tecumseh recoil w/30'' pan

Model 927011 (RM830e) 8 H.P.
Briggs elec. start w/30'' pan

Model 927012 (RM832) 8 H.P.
Briggs recoil w/32'' pan

Model 927013 (RM832e) 8 H.P.
Briggs elec. start w/32'' pan

Model 927014 (RM830) 8 H.P.
Tecumseh recoil w/30'' pan

Model 927015 (RM1032) 10 H.P.
Briggs recoil w/32'' pan

Model 927016 (RM1032e) 10 H.P.
Briggs elec. start w/32'' pan

Model 927017 (SRM830) 8 H.P.
Tecumseh recoil w/30'' pan

Model 927018 (SRM626) 6 H.P.
Tecumseh recoil w/28'' pan

Model 927020 (SRM1030) 10 H.P.
Tecumseh recoil w/30'' pan

Model 927021 (RM828) 8 H.P.
Tecumseh recoil w/28'' pan

Model 927023 (RM1032e) 10 H.P.
Briggs elec. start w/32'' pan

Model 927024 (RM830) 8 H.P.
Tecumseh recoil w/30'' pan

Model 927025 (RM830e) 8 H.P.
Briggs recoil w/30'' pan

Model 927026 (RM1032) 10 H.P.
Tecumseh recoil w/32'' pan

Model 927027 (SRM830) 8 H.P.
Briggs recoil w/30'' pan

A message to the Ariens Dealer

This Repair Manual has been prepared to assist the Ariens Dealer in providing quality service for the products listed. Additional information on these products is available from AriensService, Ariens Company, Brillion, Wisconsin 54110-1098 U.S.A. Telephone: (414)756-2141. Refer also to Parts Manual.

A warning and message to the Ariens Customer

This Repair Manual is intended for use by Ariens Dealers' trained servicemen. The information and instructions contained herein serve as a supplement to and reminder of training sessions conducted by Ariens Company. Before you attempt any repair, adjustment or maintenance project outlined in this manual, be certain of the following:

1. That you have read and fully understand the instructions in this manual.
2. That you have all of the tools, replacement parts and other materials required to complete the project.
3. Follow all instructions exactly as given.

All fittings, measurements, torque recommendations and the like are significant and approximations or substitutions must be avoided. Improper repair, maintenance and/or adjustments or service attempted by anyone other than an authorized Ariens Service Dealer could void future warranty claims, and cause damage to the unit and/or result in injury to the operator and/or bystanders.



ARIENS COMPANY
655 West Ryan Street
Brillion, Wisconsin
54110-1098 U.S.A.

Part No. RM927-1983
Printed in U.S.A. 6-83



CONTENTS

Instructions for Safe Operation	2
927000 Series Riding Mower Specifications	3-6
927000 Series Cross Reference Guide	7
927000 Series Trouble Shooting Guide	8-10
Functional Systems	11-19
Speed Selector, Drive Clutch and Parking Brake Systems, Diagram A	11-12
Brake System, Diagram B	13-14
Mower Clutch and Brake Systems, Diagram C	15-16
Mower Height Adjustment System, Diagram D	17-18
Steering System, Diagram E	19
Electrical Systems	20-22
Adjustments/Maintenance	23-33
Lubrication	34
Repair	35-40
Carrier Assembly (627028)—Die Cast	35
Transfer Frame Assembly (627000)—Stamped	36
Mower Spindle Assembly	37
Drive Assembly	38-39
Gear Case Assembly (527007)	39-40
Storage	41
Attachments and Accessories, Service Assemblies	42-59
Grass Bagger Models 827020, 21	42-51
Vane Service Assembly (527011)	52
Screen Update Service Assembly (527013)	52
Spring and Link Parts Package (527017)	53
Height Adjustment Service Assembly (527018)—Retro-Fit	54-58
Drive Parts Package	59
Riding Mower Performance Guide	60-65

SAFETY INSTRUCTIONS

1. Before test operating or making repairs or adjustments to the unit, read and understand the operating and safety instructions in the Owner's Manual.
2. Stop the engine, disengage the clutches, remove the key and wait for moving parts to stop before performing any repair, or maintenance adjustment procedures.
Never make any adjustment or perform any maintenance or repair procedures while the engine is running.
3. To prevent accidental starting, disconnect the spark plug wire.
4. Do repair work in well-lighted, ventilated area.
5. Always wear safety goggles when cleaning or making repairs to parts or machine.
6. Gasoline fumes are hazardous to health and are a fire hazard. Use non-flammable solvent to clean parts — **DO NOT USE GASOLINE.**
7. Use only Ariens original replacement parts in making repairs.
8. After repair procedures are performed, make sure the unit is in good operating condition and all safety devices and shields are in place and in good working condition. Be sure all fasteners are tight, all adjustments are correct and all tools are removed.

TORQUE VALUES

Common bolts and nuts.		Tightening Torque $\pm 20\%$		
SIZE	GRADE 2 	GRADE 5 	GRADE 8 	
1/4-20	70 in.-lb.	115 in.-lb.	165 in.-lb.	
1/4-28	85 in.-lb.	140 in.-lb.	200 in.-lb.	
5/16-18	150 in.-lb.	250 in.-lb.	350 in.-lb.	
5/16-24	165 in.-lb.	270 in.-lb.	30 ft.-lb.	
3/8-16	260 in.-lb.	35 ft.-lb.	50 ft.-lb.	
3/8-24	300 in.-lb.	40 ft.-lb.	60 ft.-lb.	
7/16-14	35 ft.-lb.	55 ft.-lb.	80 ft.-lb.	
7/16-20	45 ft.-lb.	75 ft.-lb.	105 ft.-lb.	
1/2-13	50 ft.-lb.	80 ft.-lb.	115 ft.-lb.	
1/2-20	70 ft.-lb.	105 ft.-lb.	165 ft.-lb.	
9/16-12	75 ft.-lb.	125 ft.-lb.	175 ft.-lb.	
9/16-18	100 ft.-lb.	165 ft.-lb.	230 ft.-lb.	
5/8-11	110 ft.-lb.	180 ft.-lb.	260 ft.-lb.	
5/8-18	140 ft.-lb.	230 ft.-lb.	330 ft.-lb.	
3/4-10	150 ft.-lb.	245 ft.-lb.	350 ft.-lb.	
3/4-16	200 ft.-lb.	325 ft.-lb.	470 ft.-lb.	

SERVICE POSITION DESIGNATION SYMBOLS

These symbols are used in this manual to clarify illustration service positions.

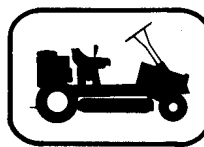

SIDE VIEW WITH PAN



SIDE VIEW WITHOUT PAN



BOTTOM VIEW WITH PAN

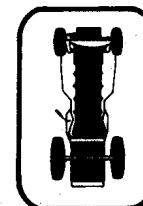

BOTTOM VIEW WITHOUT PAN

927000 SERIES RIDING MOWER SPECIFICATIONS

927000 Riding Mower	Sales No.	Engine Information	Owner's Manual	Parts Manual
927001	RM728	Tec. Recoil	27191	PM-27-80
927002	RM626	Tec. Recoil	27191	PM-27-80
927003	RM626	Tec. Recoil	27238A	PM-27-81
927004	RM830e	Briggs Elect.	27191	PM-27-80
927005	RM832	Tec. Recoil	27191	PM-27-80
927006	RM832e	Briggs Elect.	27191	PM-27-80
927007	RM1032	Tec. Recoil	27191	PM-27-80
927008	RM1032e	Tec. Recoil	27191	PM-27-80
927009	RM828	Briggs Recoil	27238A	PM-27-81
927010	RM830	Tec. Recoil	27238A	PM-27-81
927011	RM830e	Briggs Elect.	27238A	PM-27-81
927012	RM832	Briggs Recoil	27238A	PM-27-81
927013	RM832e	Briggs Elect.	27238A	PM-27-81
927014	RM830	Tec. Recoil	27191	PM-27-80
927015	RM1032	Briggs Recoil	27238A	PM-27-81

927000 Riding Mower	Sales No.	Engine Information	Owner's Manual	Parts Manual
927016	RM1032e	Briggs Elect.	27238A	PM-27-81
927017	SRM830	Tec. Recoil	27330	PM-27-81, 82
927018	SRM626	Tec. Recoil	27330A	PM-27-82, 83
927020	SRM1030	Tec. Recoil	27330A	PM-27-82, 83
927021	RM828	Tec. Recoil	27335A	PM-27-82
927023	RM1032e	Briggs Elect.	27335B	PM-27-82, 83
927024	RM830	Tec. Recoil	27335B	PM-27-82, 83
927025	RM830e	Briggs Elect.	27335B	PM-27-82, 83
927026	RM1032	Tec. Recoil	27335A	PM-27-82, 83
927027	SRM830	Briggs Recoil	27330A	PM-27-83

827000 Attachments	Requirements (for attachment to product)	Owner's Manual	Parts Manual
825002 Dozer Blade 40"	Tire Chains - 703944, 703985	79205A	PM-27-80, 81, 82, 83
827002 Grass Collector 28" ①	Fits 927001, 9	27221A	PM-27-80, 81
827004 Grass Collector 26"	Fits 927002, 3	27221A	PM-27-80, 81
827005 Grass Bagger 26"	Fits 927002, 3	27219A	PM-27-80, 81
827006 Grass Bagger 28" ①	Fits 927001, 9	27219A	PM-27-80, 81
827007 Grass Bagger 32" ①	Fits 927005, 6, 7, 8, 12, 13, 15, 16	27219A	PM-27-80, 81
827008 Grass Collector 32" ①	Fits 927005, 6, 7, 8, 12, 13, 15, 16	27221A	PM-27-80, 81
827009 Grass Bagger 30" ①	Fits 927004, 10, 11, 14	27219A	PM-27-80, 81
827020 Grass Bagger 26" and 30" ①	Fits all 927000 26" and 30"	27313B	PM-27-82, 83
827021 Grass Bagger 28" and 32" ①	Fits all 927000 28" and 32"	27313B	PM-27-82, 83

① Available High Performance Accessories for Grass Bagging or Collecting are:

927009 (Serial No. 000501 and up)	927010 (Serial No. 001001 and up)	927011 (Serial No. 001001 and up)	927012 (Serial No. 000101 and up)	927013 (Serial No. 000101 and up)	927015 (Serial No. 000501 and up)	927016 (Serial No. 000501 and up)	927017/927027 (Serial No. 000101 and up)	927020 (Serial No. 000101 and up)
727008-28"	727011-30"	727011-30"	727009-32"	727012-32"	727012-32"	727012-32"	727011-30"	727011-30"
727010-28"			727012-32"					

High Performance Flanges and Blade Tray Assemblies are included on Models: 827020 (30" only) (Serial No. 004001 and up)
827021 (32" only) (Serial No. 002701 and up)

NOTE: FOR SRM MODELS A SERVICE BAR MUST BE INSTALLED FOR BAGGER OR COLLECTOR INSTALLATION. ALSO, A BLADE TRAY ASSEMBLY SUPPLIED WITH LATER MODEL GRASS BAGGERS MUST BE INSTALLED FOR USE WITH HIGH PERFORMANCE FLANGES ON 30" MODELS (EARLY 30" RM MODELS 927024 AND 927025 HAVE THE BLADE TRAY AS STANDARD EQUIPMENT).

727000 Accessories	Requirements (for attachment to product)	Instruction Sheet	Parts Manual
703944 Tire Chains	For 4.80-4.00 x 8 tires	—	PM-27-80, 81, 82, 83
703985 Tire Chains	For 16-6.50 x 8 tires	—	PM-27-80, 81, 82, 83
722007 Electric Starter Kit - 120 Volt	Fits 927002, 3	79290D	PM-27-81
724007 Electric Starter Kit - 120 Volt	Fits 927001, 5, 7, 9, 10, 14, 20, 24, 26	79290D	PM-27-81, 82, 83
725002 Grass Catcher	Fits 927004, 10, 11, 14		
725003 Mulcher Kit - 26" and 30"	Fits 927002, 4, 10, 11, 14	79240A	PM-27-80, 81, 82
727001 Electric Starter Kit - 12 Volt	Fits 927002, 3	27158B	PM-27-80, 81
727002 Electric Starter Kit - 12 Volt	Fits 927001, 5, 7, 9, 10, 14, 20, 21, 24, 26	27158B	PM-27-80, 81, 82, 83
727003 Electric Starter Kit - 12 Volt	Fits 927001, 5, 7, 9, 10, 14, 20, 21, 24, 26	27165B	PM-27-80, 81
727004 Mulcher Kit - 28"	Fits 927001, 3, 9, 21	79507A	PM-27-80, 81, 82
727008 High Performance Accessory - 28"	Fits 927001 (All Serial No's)	79599	PM-27-81
727009 High Performance Accessory - 32"	Fits 927009 (up to Serial No. 000501) Fits 927005, 6, 7, 8 (All Serial No's)	79599	PM-27-81
727010 High Performance Accessory - 28"	Fits 927015, 16 (up to Serial No. 000501)		
727011 High Performance Accessory - 30"	Fits 927009 (Serial No. 000501 and up) Fits 927010, 11 (Serial No. 001001 and up)	79635	PM-27-81, 82 PM-27-81, 82
727012 High Performance Accessory - 32"	Fits 927017, 20 (All Serial No's) Fits 927012, 13 (Serial No. 000101 and up) Fits 927015, 16 (Serial No. 000501 and up)	79635	PM-27-81, 82

927000 SERIES RIDING MOWER SPECIFICATIONS

927

Model	RM626	RM728	RM828	RM830
Engine	Tecumseh	Tecumseh	Tecumseh	Tecumseh
HP	6 HP	7 HP	8 HP	8 HP
Starting	Recoil Elec. Start Opt.	Recoil Elec. Start Opt.	Recoil Elec. Start Opt.	Recoil Elec. Start Opt.
Key Switch	Yes	Yes	Yes	Yes
Speeds:				
Forward	6	6	6	6
Reverse	1	1	1	1
Deck Width	26'' (66 cm)	28'' (71 cm)	28'' (71 cm)	30'' (76 cm)
Cutting Height	1 1/2'' - 4 1/2'' (3.8-11 cm)	1'' - 4'' (2.5-10 cm)	1'' - 4'' (2.5-10 cm)	1 1/2'' - 4 1/2'' (3.8-11 cm)
Geared Steering	Yes	Yes	Yes	Yes
Gas Tank Capacity	2 qts. (1.9 liters)	3 qts. (2.8 liters)	3 qts. (2.8 liters)	3 qts. (2.8 liters)
Turning Radius (Inside Rear Tire)	Min. 26'' (Min. 66 cm)	Min. 26'' (Min. 66 cm)	Min. 26'' (Min. 66 cm)	Min. 26'' (Min. 66 cm)
Grass Collector	Yes (Opt.)	Yes (Opt.)	Yes (Opt.)	No
Grass Bagger	Yes (Opt.)	Yes (Opt.)	Yes (Opt.)	Yes (Opt.)
Tires:				
Front	Pneumatic 4.10-3.50 x 4	Pneumatic 4.10-3.50 x 4	Pneumatic 4.10-3.50 x 4	Pneumatic 4.10-3.50 x 4
Rear	Pneumatic 4.80-4.00 x 8	Pneumatic 4.80-4.00 x 8	Pneumatic 4.80-4.00 x 8	Pneumatic 16-6.50 x 8
Dimensions:				
Length	62 1/2'' (158 cm)	62 1/2'' (158 cm)	62 1/2'' (158 cm)	62 1/2'' (158 cm)
Width	38'' (96 cm)	34'' (86 cm)	34'' (86 cm)	41'' (104 cm)
Height	39'' (99 cm)	39'' (99 cm)	39'' (99 cm)	39'' (99 cm)
Shipping Wt.	375 lbs. (170 kg)	375 lbs. (170 kg)	375 lbs. (170 kg)	375 lbs. (170 kg)
Wheelbase	45 1/2'' (115 cm)	45 1/2'' (115 cm)	45 1/2'' (115 cm)	45 1/2'' (115 cm)
*Spark Plug Gap	.030''	.030''	.030''	.030''
*Engine Oil Capacity	2 Pints (Models 927001, 2, 3, 7, 8, 9, 10, 14, 17, 18, 20, 21, 24, 26) 2 1/4 Pints (Models 927004, 6, 11, 12, 13, 15, 16, 23, 25)			
*Engine Oil Type(s)	Above 32°F (0°C): 30W (SAE) or 10W-40 Below 32°F (0°C): 5W-30 (SAE) (Models 927001, 2, 3, 7, 8, 9, 10, 14, 17, 18, 20, 21, 24, 26) 10W-30 (SAE) (Models 927004, 6, 11, 12, 13, 15, 16, 23, 25)			
Transmission Lubrication	Ariens Premium Multi-Purpose Grease (Part No. 000150)			
Tire Pressure — F/R —	12 - 16 PSI — Front*** 10 - 12 PSI — Rear			
*Fuel Type	Regular, Unleaded (Models 927001, 2, 3, 7, 8, 9, 10, 14, 17, 18, 20, 21, 24, 26) Regular or Low-Leaded (Models 927004, 6, 11, 12, 13, 15, 16, 23, 25)			

*Refer Also to your Engine Manual.

**Semi-Pneumatic on SRM Models except 927027

***Service Bar Assembly must be installed for SRM Models.

927000 SERIES RIDING MOWER SPECIFICATIONS

Model	SRM626	SRM830	SRM830(927027)	SRM1030
Engine	Tecumseh	Tecumseh	Briggs	Tecumseh
HP	6 HP	8 HP	8 HP	10 HP
Starting	Recoil	Recoil	Recoil	Recoil Elec. Start Opt.****
Key Switch	Yes	Yes	Yes	Yes
Speeds:				
Forward	6	6	6	6
Reverse	1	1	1	1
Deck Width	26'' (66 cm)	30'' (76 cm)	30'' (76 cm)	30'' (76 cm)
Cutting Height	1 1/2'' - 4 1/2'' (3.8-11 cm)	1 1/2'' - 4 1/2'' (3.8-11 cm)	1 1/2'' - 4 1/2'' (3.8-11 cm)	1 1/2'' - 4 1/2'' (3.8-11 cm)
Geared Steering	Yes	Yes	Yes	Yes
Fuel Tank Capacity	2 qts. (1.9 liters)	3 qts. (2.8 liters)	3 qts. (2.8 liters)	3 qts. (2.8 liters)
Turning Radius (Inside Rear Tire)	Min. 26'' (Min. 66 cm)	Min. 26'' (Min. 66 cm)	Min. 26'' (Min. 66 cm)	Min. 26'' (Min. 66 cm)
Grass Collector***	Yes (Opt.) ****	No	No	No
Grass Bagger***	Yes (Opt.)	Yes (Opt.)	Yes (Opt.)	Yes (Opt.)
Tires:				
Front	Semi-Pneumatic 10.50 x 3.50	Semi-Pneumatic 10.50 x 3.50	Pneumatic 4.10-3.50 x 4	Semi-Pneumatic 10.50 x 3.50
Rear	Pneumatic 4.80-4.00 x 8	Pneumatic 4.80-4.00 x 8	Pneumatic 4.80-4.00 x 8	Pneumatic 16-6.50 x 8
Dimensions:				
Length	62 1/2'' (158 cm)	62 1/2'' (158 cm)	62 1/2'' (158 cm)	62 1/2'' (158 cm)
Width	38'' (96 cm)	41'' (104 cm)	41'' (104 cm)	41'' (104 cm)
Height	39'' (99 cm)	39'' (99 cm)	39'' (99 cm)	39'' (99 cm)
Shipping Wt.	375 lbs. (170 kg)	375 lbs. (170 kg)	375 lbs. (170 kg)	390 lbs. (176 kg)
Wheelbase	45 1/2'' (115 cm)	45 1/2'' (115 cm)	45 1/2'' (115 cm)	45 1/2'' (115 cm)
*Spark Plug Gap	.030''	.030''	.030''	.030''
*Engine Oil Capacity	2 Pints (Models 927001, 2, 3, 7, 8, 9, 10, 14, 17, 18, 20, 21, 24, 26) 2 1/4 Pints (Models 927004, 6, 11, 12, 13, 15, 16, 23, 25, 27)			
*Engine Oil Type(s)	Above 32°F (0°C): 30W (SAE) or 10W-40 Below 32°F (0°C): 5W-30 (SAE) (Models 927001, 2, 3, 7, 8, 9, 10, 14, 17, 18, 20, 21, 24, 26) 10W-30 (SAE) (Models 927004, 6, 11, 12, 13, 15, 16, 23, 25, 27)			
Transmission Lubrication	Ariens Premium Multi-Purpose Grease (Part No. 000150)			
Tire Pressure F/R**	10 - 12 PSI — Rear			
*Fuel Type	Regular, Unleaded (Models 927001, 2, 3, 7, 8, 9, 10, 14, 17, 18, 20, 21, 24, 26) Regular or Low-Leaded (Models 927004, 6, 11, 12, 13, 15, 16, 23, 25, 27)			

*Refer Also to your Engine Manual.

**Semi-Pneumatic on SRM Models except 927027

***Service Bar Assembly must be installed for SRM Models.

****Electric Start is available for RM 1032 Models with Tecumseh engine.

927000 SERIES RIDING MOWER SPECIFICATIONS

927

Model	RM830e	RM832	RM832e	RM1032	RM1032e
Engine	Briggs & Stratton	Briggs & Stratton	Briggs & Stratton	B & S or Tec.	Briggs & Stratton
HP	8 HP	8 HP	8 HP	10 HP	10 HP
Starting	Electric & Recoil	Recoil	Electric & Recoil	Recoil ****	Electric & Recoil
Key Switch	Yes	Yes	Yes	Yes	Yes
Speeds:					
Forward	6	6	6	6	6
Reverse	1	1	1	1	1
Deck Width	30" (76 cm)	32" (81 cm)	32" (81 cm)	32" (81 cm)	32" (81 cm)
Cutting Height	1 1/2" - 4 1/2" (3.8-11 cm)	1" - 4" (2.5-10 cm)	1" - 4" (2.5-10 cm)	1" - 4" (2.5-10 cm)	1" - 4" (2.5-10 cm)
Geared Steering	Yes	Yes	Yes	Yes	Yes
Gas Tank Capacity	3 qts. (2.8 liters)	3 qts. (2.8 liters)	3 qts. (2.8 liters)	3 qts. (2.8 liters)	3 qts. (2.8 liters)
Turning Radius (Inside Rear Tire)	Min. 26" (Min. 66 cm)	Min. 26" (Min. 66 cm)	Min. 26" (Min. 66 cm)	Min. 26" (Min. 66 cm)	Min. 26" (Min. 66 cm)
Grass Collector	No	Yes (Opt.)	Yes (Opt.)	Yes (Opt.)	Yes (Opt.)
Grass Bagger	Yes (Opt.)	Yes (Opt.)	Yes (Opt.)	Yes (Opt.)	Yes (Opt.)
Tires:					
Front	Pneumatic 4.10-3.50 x 4	Pneumatic 4.10-3.50 x 4	Pneumatic 4.10-3.50 x 4	Pneumatic 4.10-3.50 x 4	Pneumatic 4.10-3.50 x 4
Rear	Pneumatic 16-6.50 x 8	Pneumatic 16-6.50 x 8	Pneumatic 16-6.50 x 8	Pneumatic 16-6.50 x 8	Pneumatic 16-6.50 x 8
Dimensions:					
Length	62 1/2" (158 cm)	62 1/2" (158 cm)	62 1/2" (158 cm)	62 1/2" (158 cm)	62 1/2" (158 cm)
Width	41" (104 cm)	39" (99 cm)	39" (99 cm)	39" (99 cm)	39" (99 cm)
Height	39" (99 cm)	39" (99 cm)	39" (99 cm)	39" (99 cm)	39" (99 cm)
Shipping Wt.	375 lbs. (170 kg)	375 lbs. (170 kg)	390 lbs. (176 kg)	390 lbs. (176 kg)	390 lbs. (176 kg)
Wheelbase	45 1/2" (115 cm)	45 1/2" (115 cm)	45 1/2" (115 cm)	45 1/2" (115 cm)	45 1/2" (115 cm)
*Spark Plug Gap	.030"	.030"	.030"	.030"	.030"
*Engine Oil Capacity	2 Pints (Models 927001, 2, 3, 7, 8, 9, 10, 14, 17, 18, 20, 21, 24, 26) 2 1/4 Pints (Models 927004, 6, 11, 12, 13, 15, 16, 23, 25)				
*Engine Oil Type(s)	Above 32°F (0°C): 30W (SAE) or 10W-40 Below 32°F (0°C): 5W-30 (SAE) (Models 927001, 2, 3, 7, 8, 9, 10, 14, 17, 18, 20, 21, 24, 26) 10W-30 (SAE) (Models 927004, 6, 11, 12, 13, 15, 16, 23, 25)				
Transmission Lubrication	Ariens Premium Multi-Purpose Grease (Part No. 000150)				
Tire Pressure — F/R —	12 - 16 PSI — Front** 10 - 12 PSI — Rear				
*Fuel Type	Regular, Unleaded (Models 927001, 2, 3, 7, 8, 9, 10, 14, 17, 18, 20, 21, 24, 26) Regular or Low-Leaded (Models 927004, 6, 11, 12, 13, 15, 16, 23, 25)				

*Refer Also to your Engine Manual.

**Semi-Pneumatic on SRM Models except 927027

***Service Bar Assembly must be installed for SRM Models.

****Electric Start is available for RM 1032 Models with Tecumseh engine.

927000 SERIES CROSS-REFERENCE GUIDE

ENGINES

MODEL NO.	DESCRIPTION	ENGINE	ARIENS NUMBER
927001	7 HP Tec. Riding Mower 28"	Tec. VM70-127006B	082128
927002	6 HP Tec. Riding Mower 26"	Tec. V60-70359J	082131
927003	6 HP Tec. Riding Mower 26"	Tec. V60-70359J	082131
927004	8 HP Briggs Riding Mower 30" Electric	Briggs 190707-1192-01	082144
927005	8 HP Tec. Riding Mower 32"	Tec. VM80-150135F	082145
927006	8 HP Briggs Riding Mower 32" Electric	Briggs 190707-1192-01	082144
927007	10 HP Tec. Riding Mower 32"	Tec. VM100-157044B	082146
927008	10 HP Tec. Riding Mower 32" Electric	Tec. VM100-157045B	082147
927009	8 HP Tec. Riding Mower 28"	Tec. VM80-150135F	082145
927010	8 HP Tec. Riding Mower 30"	Tec. VM80-150135F	082145
927011	8 HP Briggs Riding Mower 30" Electric	Briggs 190707-1192-01	082144
927012	8 HP Briggs Riding Mower 32"	Briggs 190702-1201-01	082154
927013	8 HP Briggs Riding Mower 32" Electric	Briggs 190707-1192-01	082144
927014	8 HP Tec. Riding Mower 30"	Tec. VM80-150135F	082145
927015	10 HP Briggs Riding Mower 32"	Briggs 220702 0143-01	082156
927016	10 HP Briggs Riding Mower 32" Electric	Briggs 220707 0144-01	082155
927017	8 HP Tec. Riding Mower 30"	Tec. TVM195-150139H	082161
927018	6 HP Tec. Riding Mower 26"	Tec. TVM140-70369K	082162
927020	10 HP Tec. Riding Mower 30"	Tec. TVM220-157054D	082163
927021	8 HP Tec. Riding Mower 28"	Tec. VM80 150135G	082145
927023	10 HP Briggs Riding Mower 32" Electric	Briggs 220707 0636-01	082155
927024	8 HP Tec. Riding Mower 30"	Tec. TVM195-1501354H	082145
927025	8 HP Briggs Riding Mower 30" Electric	Briggs 190707-2147-01	082144
927026	10 HP Tec. Riding Mower 32"	Tec. TVM220-157054D	082163
927027	8 HP Briggs Riding Mower 30"	Briggs 190702-2148-01	082154

BELTS

927000 SERIES RIDING MOWER BELT CROSS REFERENCE		
MODEL NO.	DRIVE BELT	MOWER BELT
927001, 9, 21	072112	072113
927002, 3, 18	072112	072115
927004, 11, 25	072112	072113
927005, 12	072112	072124
927006, 13	072112	072124
927007, 15, 26	072112	072124
927008, 16, 23	072112	072124
927010, 14, 24	072112	072113
927017, 20, 27	072112	072113

A NOTE ABOUT ARIENS BELTS

ARIENS BELTS are individually engineered to the highest standards of material quality, design, and construction including special cording locations for strength and stability. This assures that the belts will deliver maximum performance and durability for each product's specific applications.

The selling price of **ARIENS BELTS** reflects these quality features. Our name and number stamped on your replacement belt is your assurance of receiving the quality you are paying for.

927000 SERIES TROUBLE SHOOTING

- | | |
|--|---|
| 1. Front axle pivot nut loosening up. | <ul style="list-style-type: none"> a. Spacer may not be long enough. (Replace) b. There should be a lock washer under the nut. c. When replacing nut, use a new one. <p>NOTE: NUT SHOULD BE TORQUED TO 35 FT. LBS.</p> |
| 2. Shift Arm (27038) cutting battery. | <ul style="list-style-type: none"> a. Remove burrs. b. New style battery box can be added. Use Part No. 25129. |
| 3. Nut falling off of steering gear. (25061) | <ul style="list-style-type: none"> a. Part 25061 may have a burr in pivot hole. <p>NOTE: REFER TO CAMPAIGN LETTER C-103. MODELS AFFECTED ARE: MODEL 927001 101-4413; MODEL 927002 101-3899.</p> |
| 4. Service Bar tube bending. | <ul style="list-style-type: none"> a. Add Service Bar Brace (27227). |
| 5. Catcher doesn't fit properly. (Older style.) | <ul style="list-style-type: none"> a. Position 12263 bracket on R.H. side of service bar. |
| 6. 27031 clutch arm interferes with adjustment yoke. NOTE: REFER TO CAMPAIGN LETTER C-102. | <ul style="list-style-type: none"> a. Replace with clutch arm package 527010. Models affected are: Model 927001 101-2021; Model 927002 101-2659. |
| 7. When depressing clutch all the way, you cannot shift. | <ul style="list-style-type: none"> a. Adjustment nuts on clutch rod are not adjusted properly because 27150 carrier yoke hits bottom of the frame. |
| 8. Cannot shift into fifth speed. | <ul style="list-style-type: none"> a. 27008 shift rod may interfere with 27150 carrier yoke. <ul style="list-style-type: none"> 1. Grind off corner of notch in yoke. 2. Grind off end of 27008 rod. <p>Reference Product Notice N-107.</p> |
| 9. Clutch rod coming out of clutch bracket. | <ul style="list-style-type: none"> a. Replace with lock nuts. |
| 10. Engine dies when engaging mower. | <ul style="list-style-type: none"> a. Mower Belt too tight. Adjust Belt. b. Mower pan down in lush high grass when engaging. c. Engine problem. |
| 11. Friction wheel failure. (See "Drive Parts Package No. 527029" Instructions on page 70 of this manual if Rider has older style Friction Drive.) | <ul style="list-style-type: none"> a. Clutch stop bolt in wrong position. b. Perform friction wheel stop adjustment. c. Binding in system. d. Readjust clutch & brake per set-up instructions. e. Nut may be loose on carrier. f. Move spring to outer hole in clutch arm. g. Bad wheel. h. Hub out of round. |
| 12. Grease running out of gear case. | <ul style="list-style-type: none"> a. Check for a break in the gasket. b. Gear case may be over filled. c. Check for a bad seal. |
| 13. Idler spring breaking. | <ul style="list-style-type: none"> a. Burrs on idler arm - Remove with file. b. Improperly heat treated spring. (Replace) |
| 14. Loose steering. | <ul style="list-style-type: none"> a. Tighten steering gear per instructions in this manual. |
| 15. No drive. (See "Drive Parts Package No. 527029" Instructions on page 70 of this manual if Rider has older style Friction Drive). | <ul style="list-style-type: none"> a. Clutch stop not set correctly. b. Linkage hang up. c. Linkage not connected. d. Friction wheel failed. |
| 16. Noisy transmission. | <ul style="list-style-type: none"> a. Check for spacer missing in case. b. 54039 bearing failed. |

927000 SERIES TROUBLESHOOTING

- | | |
|--|--|
| 17. Poor shifting. | a. 65123 nut on ball joint not properly torqued.
b. 27008 shift link interference with yoke. To correct, widen slot in yoke. |
| 18. Carrier yoke failure. | a. Nut came off.
b. Check for proper assembly. |
| 19. Seat rubbing hole in battery. | a. Grind or bend Seat Bracket channel away. Be sure Battery terminals face the CENTER of the Riding Mower when installed. Be sure Hold-Down hardware is secure. |
| 20. Will not start. | a. Out of fuel or dirty fuel.
b. Poor spark plug or wire off.
c. Wires disconnected.
d. Mower interlock not engaging or failed.
e. Shift interlock not engaging or failed.
f. Defective interlock module.
g. Loose module causing poor ground.
h. Poor ignition switch. |
| 21. Wires burning when installing battery. | a. Wires not connected properly, check wiring diagram. |
| 22. Starter cable too short. | a. 10" long, Part 25189, is correct cable. |
| 23. Engine vibrates. | a. 27010 engine pulley out of balance.
b. 25284 disc out of balance. |
| 24. Mower belt slipping. | a. Not adjusted at front axle.
b. Misadjusted belt finger (See N-112).
c. Wrong mower pulley.
d. Adjust Mower Belt. |
| 25. Mower pan misaligned to one side. | a. Add shims under front bracket.
NOTE: THE DISTANCE FROM BLADES TO BOTTOM OF RUNNERS SHOULD BE:
26" 1.129
28" .714
30" .926 |
| 26. Mower scalping | a. Pan should be 1/8" to 3/8" lower in front.
b. Tire pressure should be corrected. Refer to "DEALER ASSEMBLY AND PRE-SERVICE" section of this manual.
c. No. 527018 Height Adjustment Kit may be installed to allow adjustment for leveling and pitch. |
| 27. Mower will not engage. | a. Wrong mower engagement link.
1. 26" link should be 5 1/4 long.
2. 28" and 30" link should be 6 3/4 long. |
| 28. Engine cuts out (Seat Switch). | a. Install Seat Switch Adjustment Package (527036), per Service Bulletin B-129.
Model 927021, Series No's 004001 - 007509
Model 927023, Series No's 002801 - 004055
Model 927027, Series No's 000101 - 003064 |

TROUBLE SHOOTING FOR GRASS BAGGERS AND COLLECTORS

927

TYPE OF FAILURE	CAUSE	SOLUTION
Unit does not operate properly — won't bag or	1) Worn or non-original equipment type blade	Be sure the mower has a sharp Ariens blade on it.
	2) Low tip speed on blade	Check engine RPM and increase to a maximum of 3300 RPM, decrease ground speed.
	3) High ground speed on mower.	Shift to lower speed. However avoid prolonged use of first speed.
	4) Grass conditions	Grass must be dry.
	5) Discharge chute clogging due to mower pan attitude.	Mower pan must hang level side to side and 1/8 inch to 3/8 inch lower in front than in rear.
	6) Grass cutting too low for first mowing	Raise mower to higher cutting height for cutting tall grass for first mowing. Then re-cut at a lower cutting height.
	7) Belt tension not properly adjusted	Adjust belt tension according to Owner's Manual and conditions.
	8) Vanes required or vanes worn down	Install or replace vanes. Order 527011 Service Vane Kit.
	9) High Performance Flange Accessory needed.	Install High Performance Flange Accessory. See Rider Performance Guide, page 75, and NOTE below.
Collector/Bagger Tube comes loose (32" Models)	1) Tube not secured	Install Latch Strap.

NOTE: A HIGH PERFORMANCE ACCESSORY FOR 28", 30" OR 32" RIDERS IS AVAILABLE FOR IMPROVED BAGGING OR COLLECTING (AS WELL AS IMPROVED MULCHING FOR THE 28" MOWER WITH MULCHER ACCESSORY). SEE "PERFORMANCE GUIDE," FOR FURTHER INFORMATION ON THESE KITS.

927000 SERIES RIDING MOWER OVERALL DIMENSIONS WITH 827020 OR 827021 GRASS BAGGER INSTALLED

MODEL NO. — RIDER	MODEL NO. — BAGGER	LENGTH	WIDTH	HEIGHT
SRM626 & RM626	827020 — 26"	83 1/2"	38"	38"
RM728 & RM828	827021 — 28"	83 1/2"	35"	38"
RM830, RM1030, SRM830 & SRM1030	827020 — 30"	83 1/2"	41"	38"
RM832 & RM1032	827021 — 32"	83 1/2"	39"	38"

FUNCTIONAL SYSTEMS

SPEED SELECTOR, DRIVE CLUTCH AND PARKING BRAKE SYSTEMS

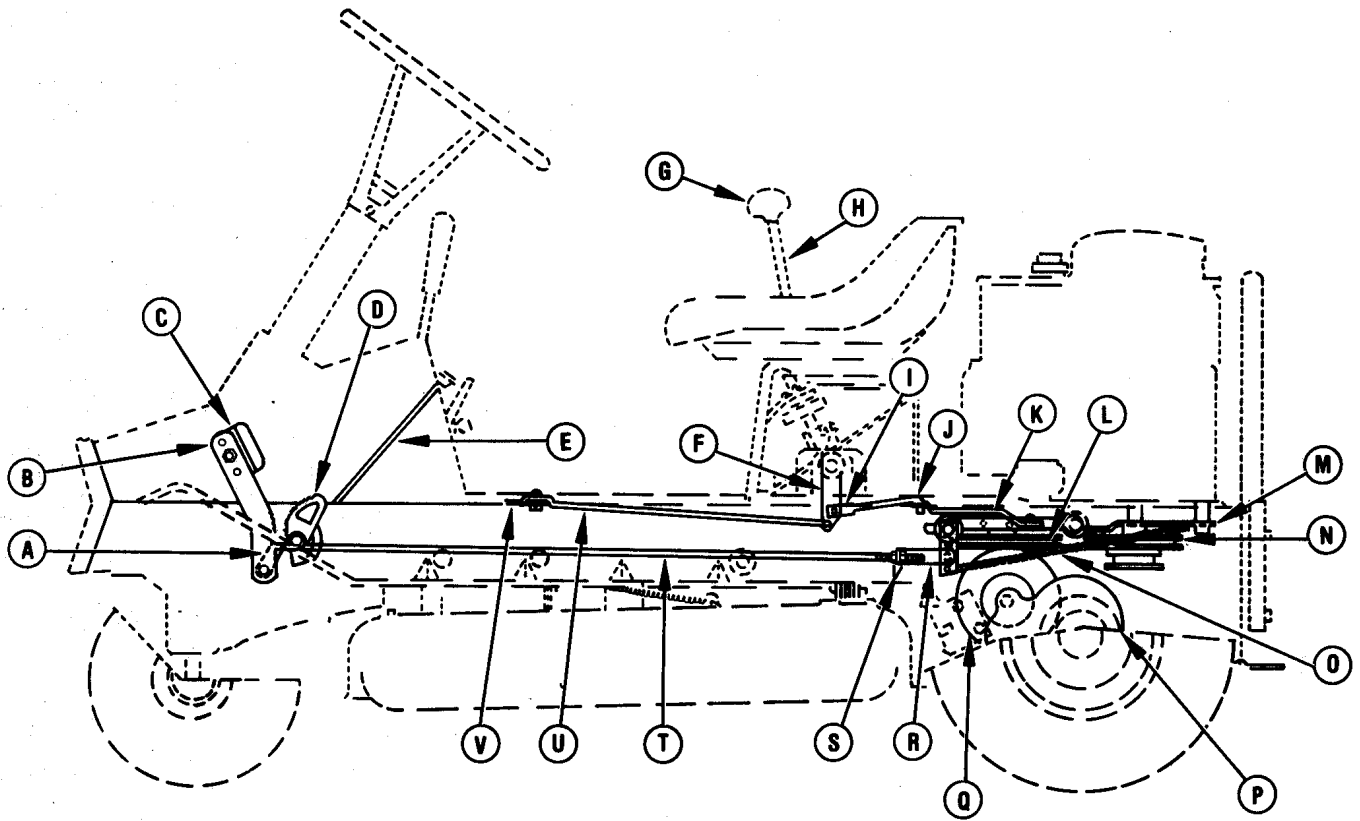

- | | |
|---|--|
| (A) CLUTCH ARM | (L) DRIVE DISC |
| (B) CLUTCH PEDAL ARM | (M) IDLER ARM |
| (C) CLUTCH PEDAL | (N) ENGINE SHEAVE |
| (D) BRAKE LATCH | (O) SPRING |
| (E) PARKING BRAKE ROD (EXCEPT SRM MODELS) | (P) GEAR CASE WITH DIFFERENTIAL (527000) |
| (F) SHIFT ARM | (Q) FRICTION WHEEL WITH FIVE CAP SCREWS |
| (G) SHIFT GRIP (SRM MODELS)
SHIFT KNOB (RM MODELS) | (R) CLUTCH BRACKET |
| (H) SHIFT LEVER | (S) CLUTCH ADJUSTMENT NUTS |
| (I) BALL JOINT | (T) CLUTCH ROD |
| (J) SHIFT ROD | (U) INDICATOR ROD |
| (K) BELLCRANK | (V) INDICATOR |

DIAGRAM A — 1

FUNCTIONAL SYSTEMS

SPEED SELECTOR, DRIVE CLUTCH AND PARKING BRAKE SYSTEMS

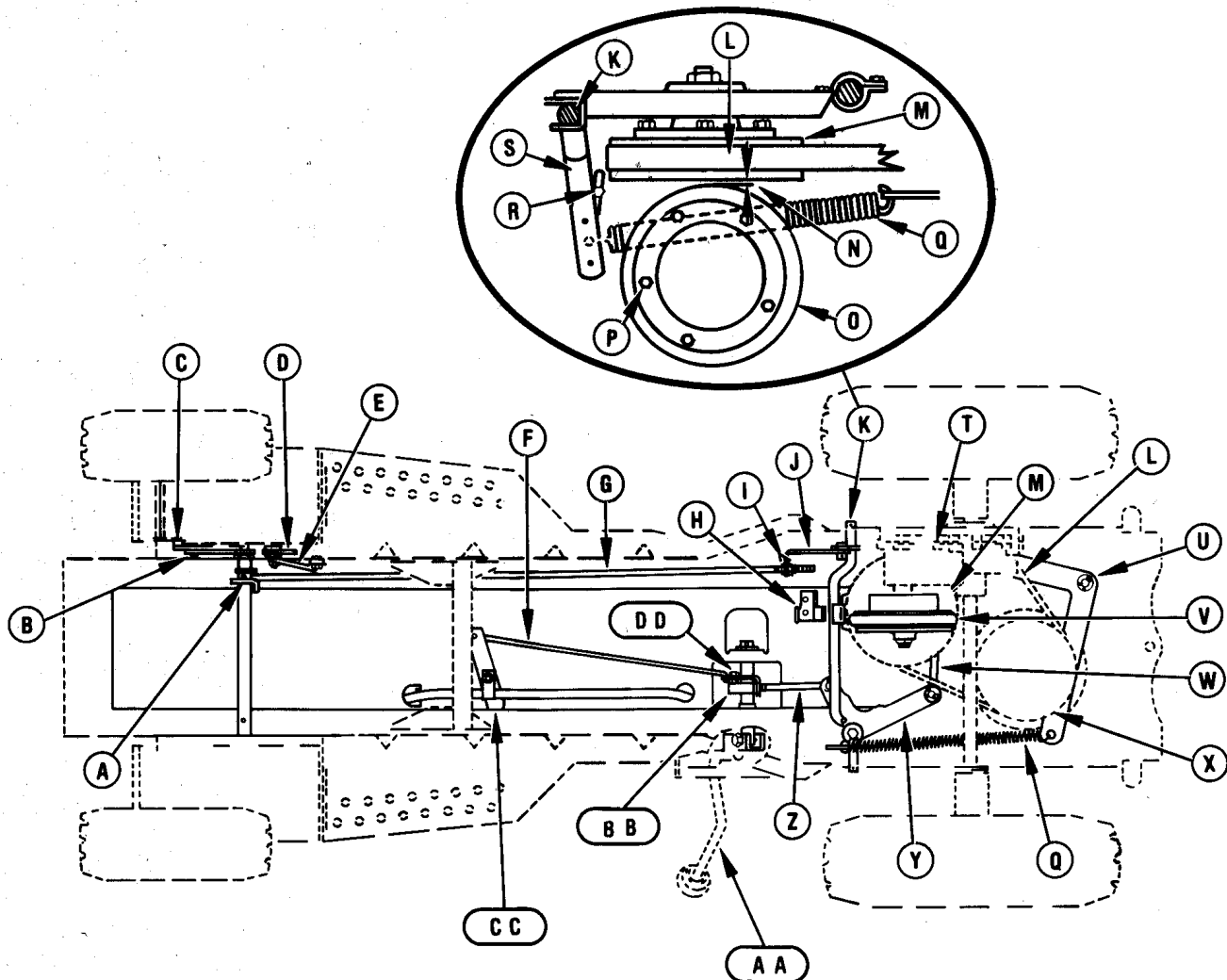

- | | |
|----------------------------|---|
| (A) CLUTCH ARM | (P) FIVE CAP SCREWS AND LOCKWASHERS |
| (B) CLUTCH PEDAL ARM | (Q) CLUTCH SPRING |
| (C) CLUTCH PEDAL | (R) CLUTCH SHAFT STOP |
| (D) BRAKE LATCH | (S) CLUTCH SHAFT ARM |
| (E) BRAKE SPRING | (T) GEAR CASE ASSEMBLY WITH DIFFERENTIAL (527007) |
| (F) INDICATOR ROD | (U) IDLER ARM |
| (G) CLUTCH ROD | (V) FRICTION WHEEL WITH FIVE CAP SCREWS |
| (H) NEUTRAL STOP | (W) SHIFT LINK |
| (I) CLUTCH ADJUSTMENT NUTS | (X) ENGINE SHEAVE |
| (J) CLUTCH BRACKET | (Y) BELLCRANK |
| (K) CLUTCH SHAFT | (Z) SHIFT ROD |
| (L) DRIVE BELT | (AA) SHIFT LEVER |
| (M) DRIVE DISC | (BB) BALL JOINT |
| (N) SET FOR MINIMUM SPACE | (CC) INDICATOR |
| (O) FRICTION WHEEL GUARD | (DD) SHIFT ARM |

DIAGRAM A — 2

FUNCTIONAL SYSTEMS

BRAKE SYSTEM

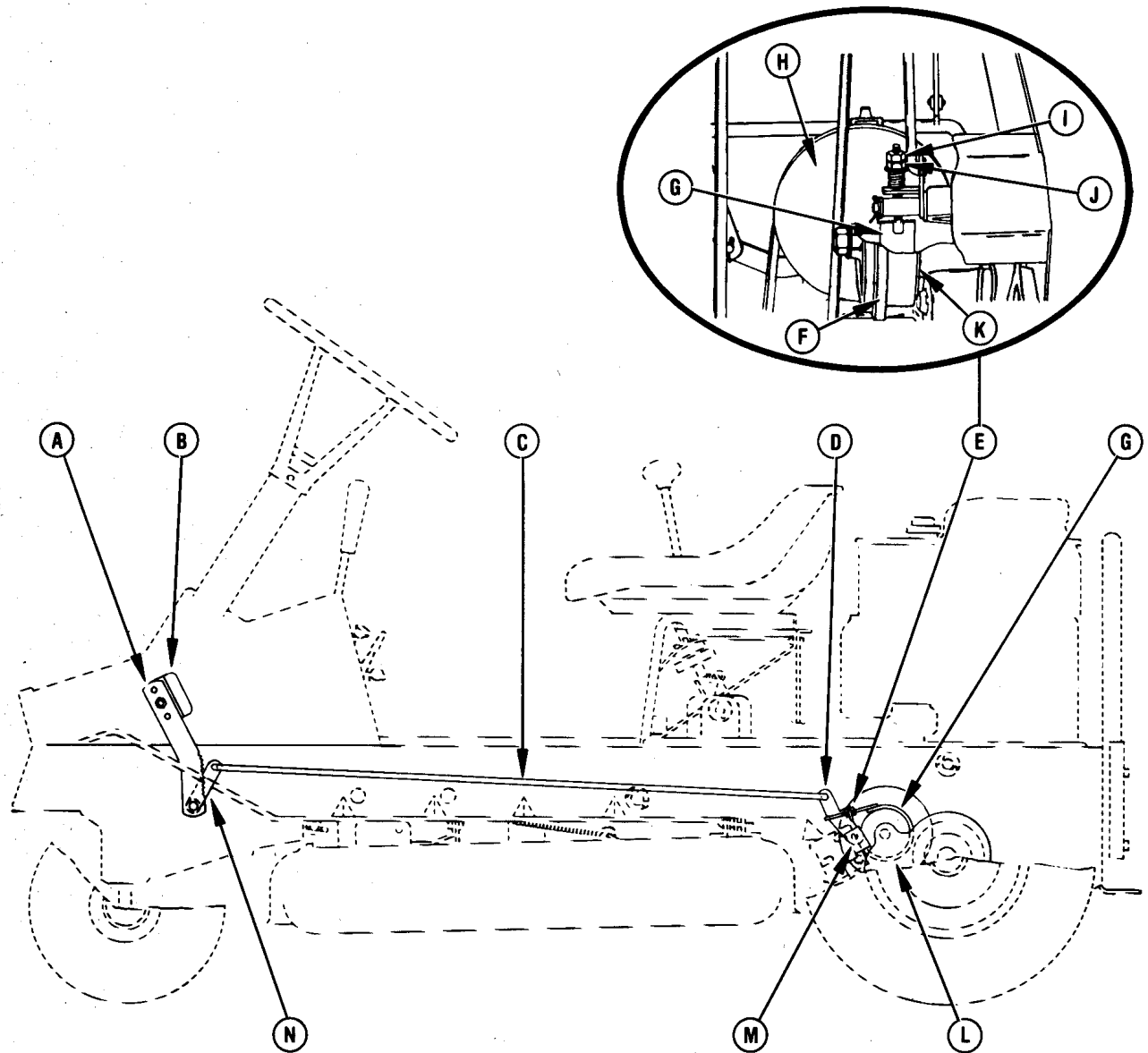

(A) BRAKE PEDAL ARM

(B) BRAKE PEDAL

(C) BRAKE ROD

(D) BRAKE LEVER

(E) BRAKE BAND ADJUSTMENT

(F) FRICTION WHEEL

(G) BRAKE BAND

(H) DRIVE DISC

(I) LOOSEN TOP NUT

(J) BOTTOM NUT ADJUSTS BRAKE

(K) BRAKE DRUM

(L) FRICTION WHEEL HUB

(M) BRAKE BRACKET

(N) BRAKE ARM

NOTE: REFER TO PM-27-83 FOR PART NUMBERS.

DIAGRAM B — 1

FUNCTIONAL SYSTEMS

BRAKE SYSTEM

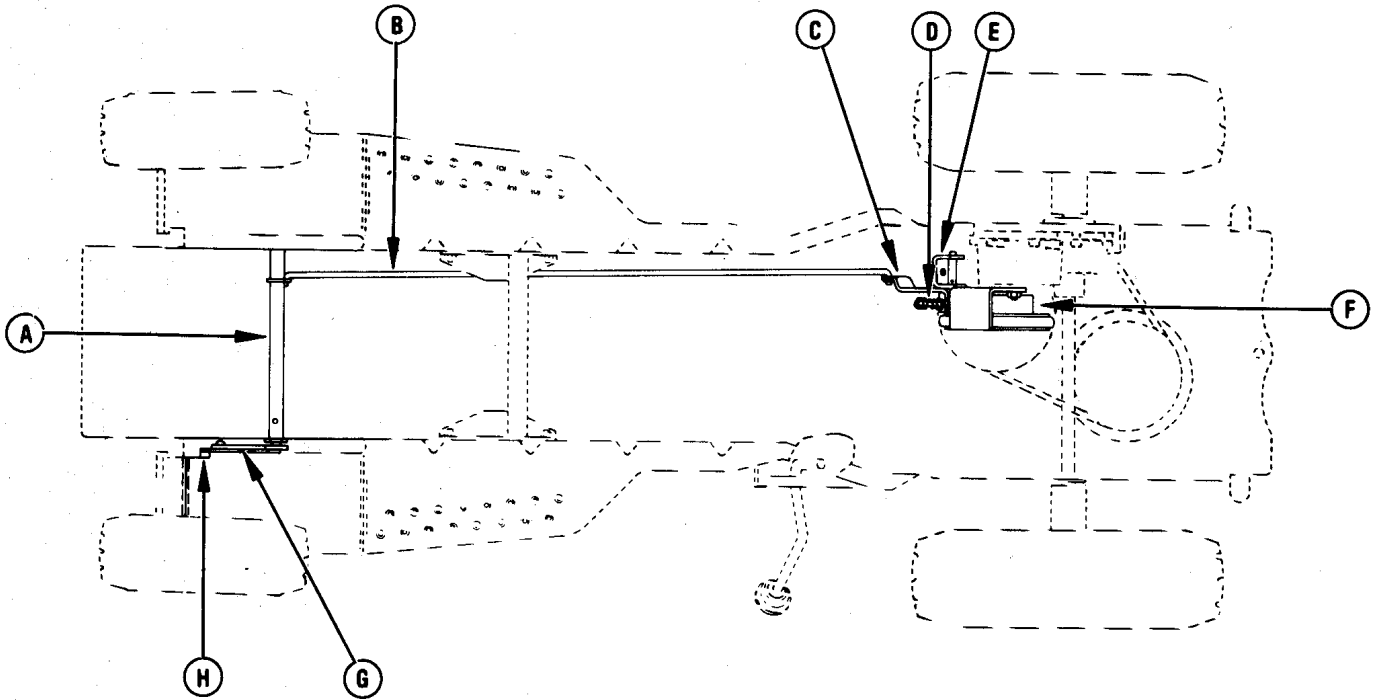

(A) BRAKE ARM
 (B) BRAKE ROD
 (C) BRAKE LEVER
 (D) BRAKE BAND ADJUSTMENT

(E) BRAKE BRACKET
 (F) BRAKE BAND
 (G) BRAKE PEDAL ARM
 (H) BRAKE PEDAL

NOTE: REFER TO PM-27-83 FOR PART NUMBERS.

DIAGRAM B — 2

FUNCTIONAL SYSTEMS

MOWER CLUTCH AND BRAKE SYSTEMS

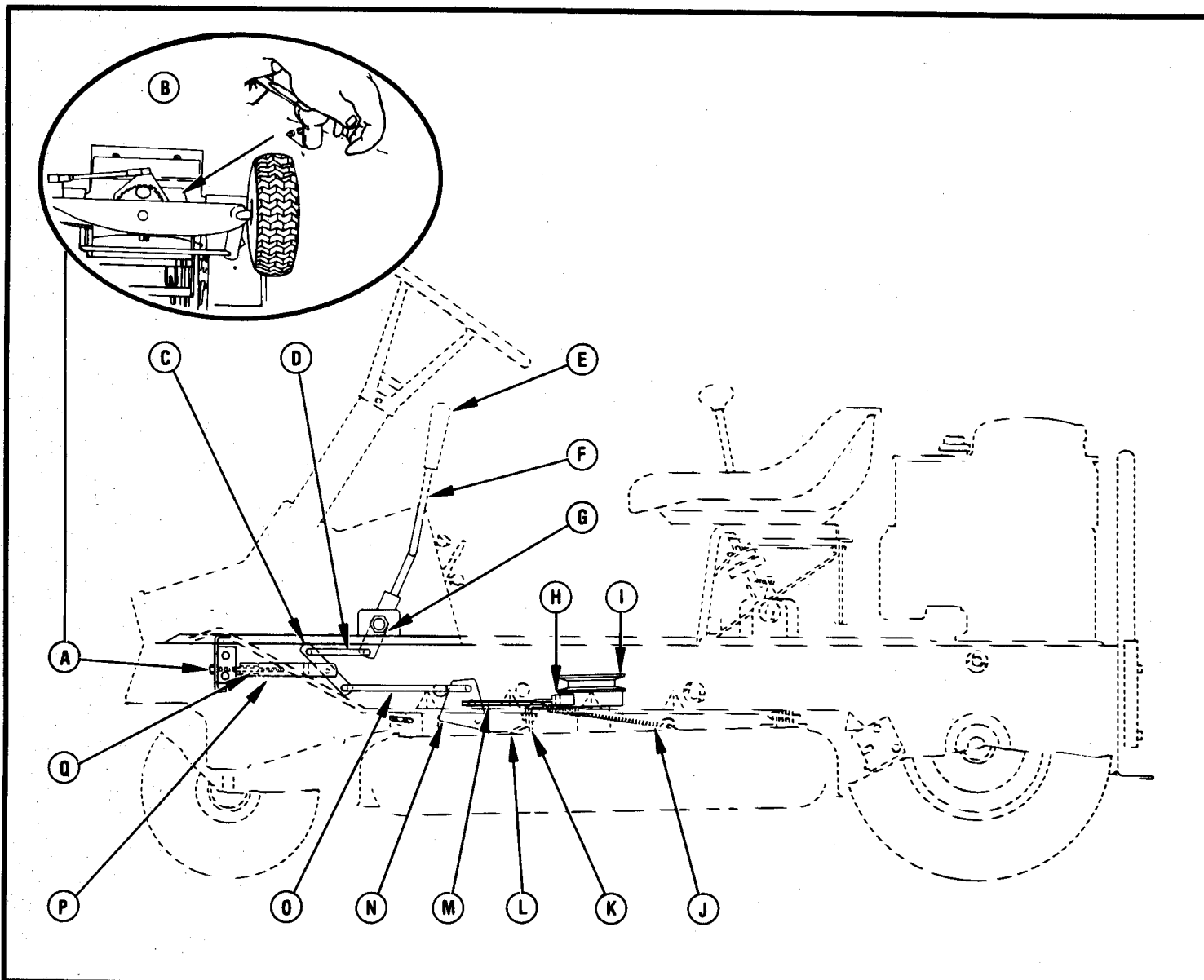

(A) MOWER BELT ADJUSTMENT
CAP SCREW (927001, 2, 4, 9, 10, 11, 14, 17, 18,
20, 21, 24, 25)
CAP SCREW (927005, 6, 7, 8, 12, 13, 15, 16, 23,
26)

(B) DEPRESS SPRING CLIP WITH WRENCH AND TURN
FOR BELT ADJUSTMENT. BE SURE SPRING CLIP
SNAPS UP TO LOCK ADJUSTMENT.

(C) CLUTCH LINK (927001, 2, 4, 9, 10, 11, 14, 17,
18, 20, 21, 24, 25)
CLUTCH LINK (927005, 6, 7, 8, 12, 13, 15, 16,
23, 26)

(D) MOWER CLUTCH LINK

(E) HANDLE (RM MODELS)
GRIP (SRM MODELS)

(F) MOWER CLUTCH LEVER

(G) CLUTCH ARM

(H) BLADE BRAKE

(I) MOWER SHEAVE

(J) SPRING

(K) BRAKE BRACKET

(L) PIVOT BRACKET

(M) MOWER BRAKE LINK

(N) MOWER ENGAGEMENT ARM

(O) MOWER ENGAGEMENT LINK

(P) FRONT ANCHOR (927005, 6, 7, 8, 12, 13, 15, 16,
23, 26)

(Q) ADJUSTMENT YOKE (927001, 2, 4, 9, 10, 11, 14,
17, 18, 20, 21, 24, 25)

NOTE: REFER TO PM-27-83 FOR PART NUMBERS.

DIAGRAM C — 1

FUNCTIONAL SYSTEMS

MOWER CLUTCH AND BRAKE SYSTEMS

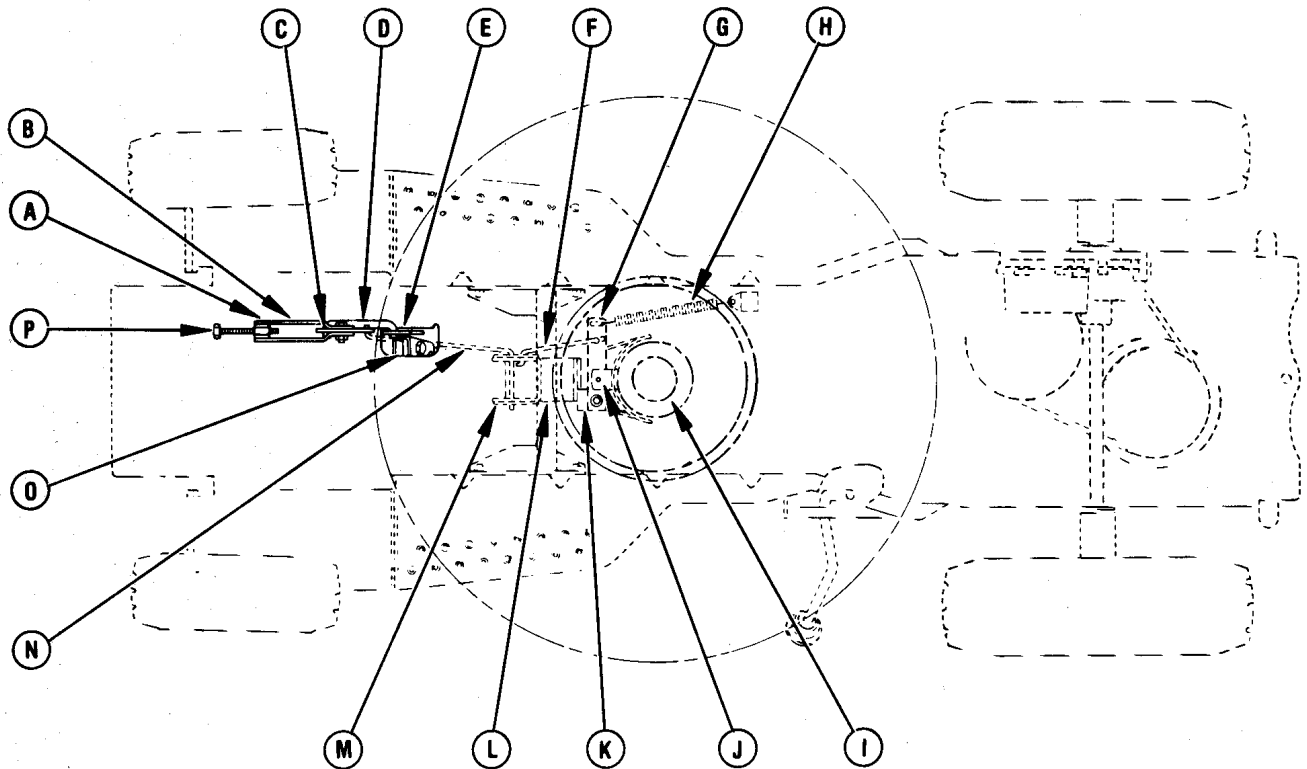

- (A) FRONT ANCHOR (927005, 6, 7, 8, 12, 13, 15, 16, 23, 26)
 (B) ADJUSTMENT YOKE (927001, 2, 4, 9, 10, 11, 14, 17, 18, 20, 21, 24, 25)
 (C) CLUTCH LINK (927001, 2, 4, 9, 10, 11, 14, 17, 18, 20, 21, 24, 25)
 CLUTCH LINK (927005, 6, 7, 8, 12, 13, 15, 16, 23, 26)
 (D) MOWER CLUTCH LINK
 (E) CLUTCH ARM
 (F) MOWER BRAKE LINK
 (G) MOWER BRAKE LEVER

- (H) SPRING
 (I) MOWER SHEAVE
 (J) BLADE BRAKE
 (K) BRAKE BRACKET
 (L) PIVOT BRACKET
 (M) MOWER ENGAGEMENT ARM
 (N) MOWER ENGAGEMENT LINK
 (O) MOWER CLUTCH LEVER
 (P) CAP SCREW (927001, 2, 4, 9, 10, 11, 14, 17, 18, 20, 21, 24, 25)
 CAP SCREW (927005, 6, 7, 8, 12, 13, 15, 16, 23, 26)

NOTE: REFER TO PM-27-83 FOR PART NUMBERS.

DIAGRAM C — 2

FUNCTIONAL SYSTEMS

MOWER HEIGHT ADJUSTMENT SYSTEM

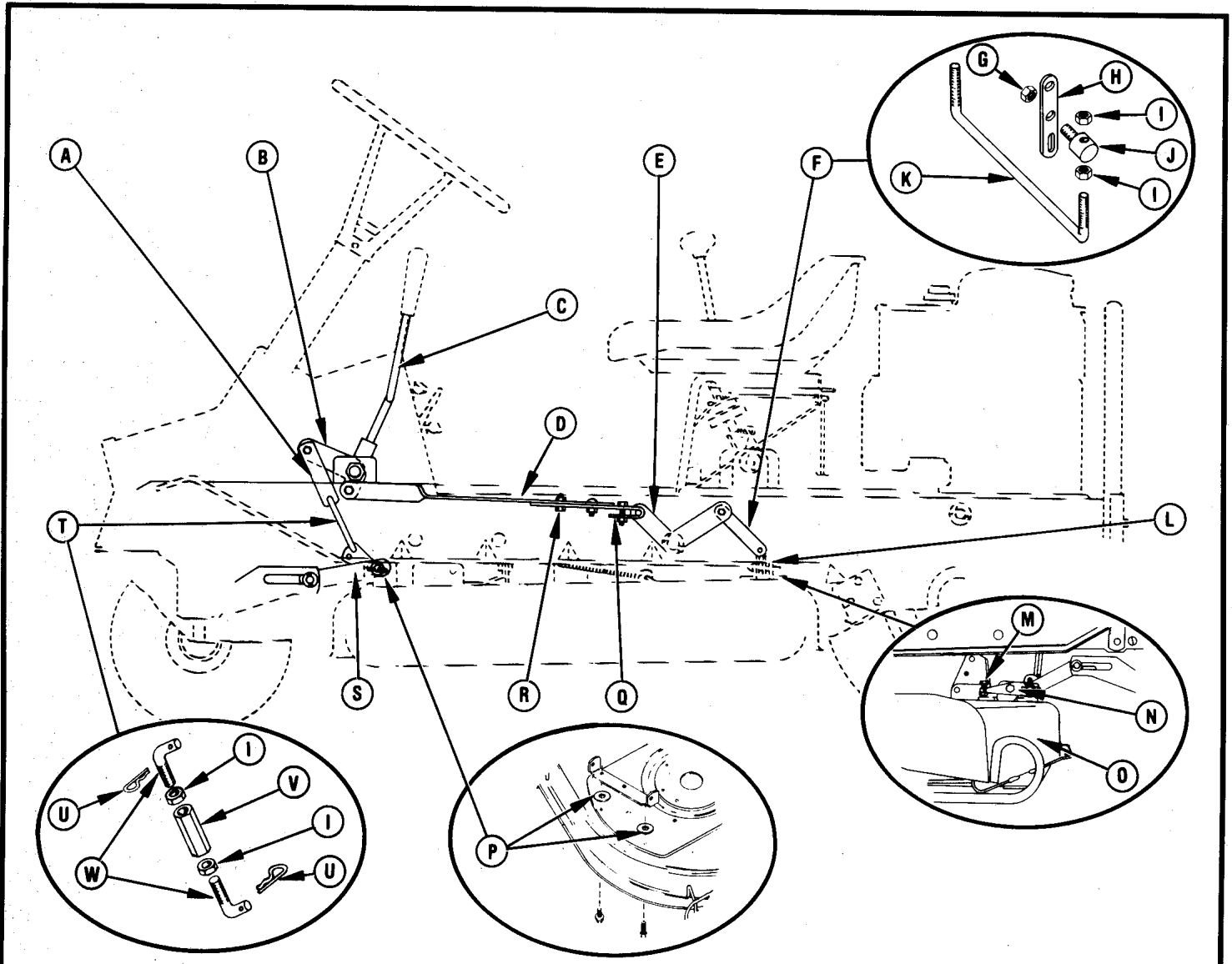

- (A) STRAP
- (B) LIFT ARM
- (C) MOWER HEIGHT LEVER
- (D) MOWER LIFT LINK
- (E) REAR MOWER HANGER
- (F) REAR ADJUSTABLE LINK
- (G) LOCKNUT
- (H) REAR LIFT LINK
- (I) JAM NUT
- (J) ROD PIVOT
- (K) REAR LIFT ROD
- (L) SWIVEL BRACKET
- (M) CAP SCREW
- (N) LEVER
- (O) MOWER PAN
- (P) ADD WASHERS AS REQUIRED.
- (Q) ADJUSTMENT STRAP
- (R) MOWER TILT ADJUSTMENT
- (S) FRONT LIFT ARM (927001, 2, 4, 9, 10, 11, 14, 17, 18, 20, 21, 24, 25)
FRONT LIFT ARM (927005, 6, 7, 8, 12, 13, 15, 16, 23, 26)
- (T) FRONT ADJUSTABLE LINK
- (U) HAIRPIN
- (V) COUPLING NUT
- (W) FRONT LIFT LINK

NOTE: REFER TO PM-27-83 FOR PART NUMBERS.

DIAGRAM D — 1

FUNCTIONAL SYSTEMS

MOWER HEIGHT ADJUSTMENT SYSTEM

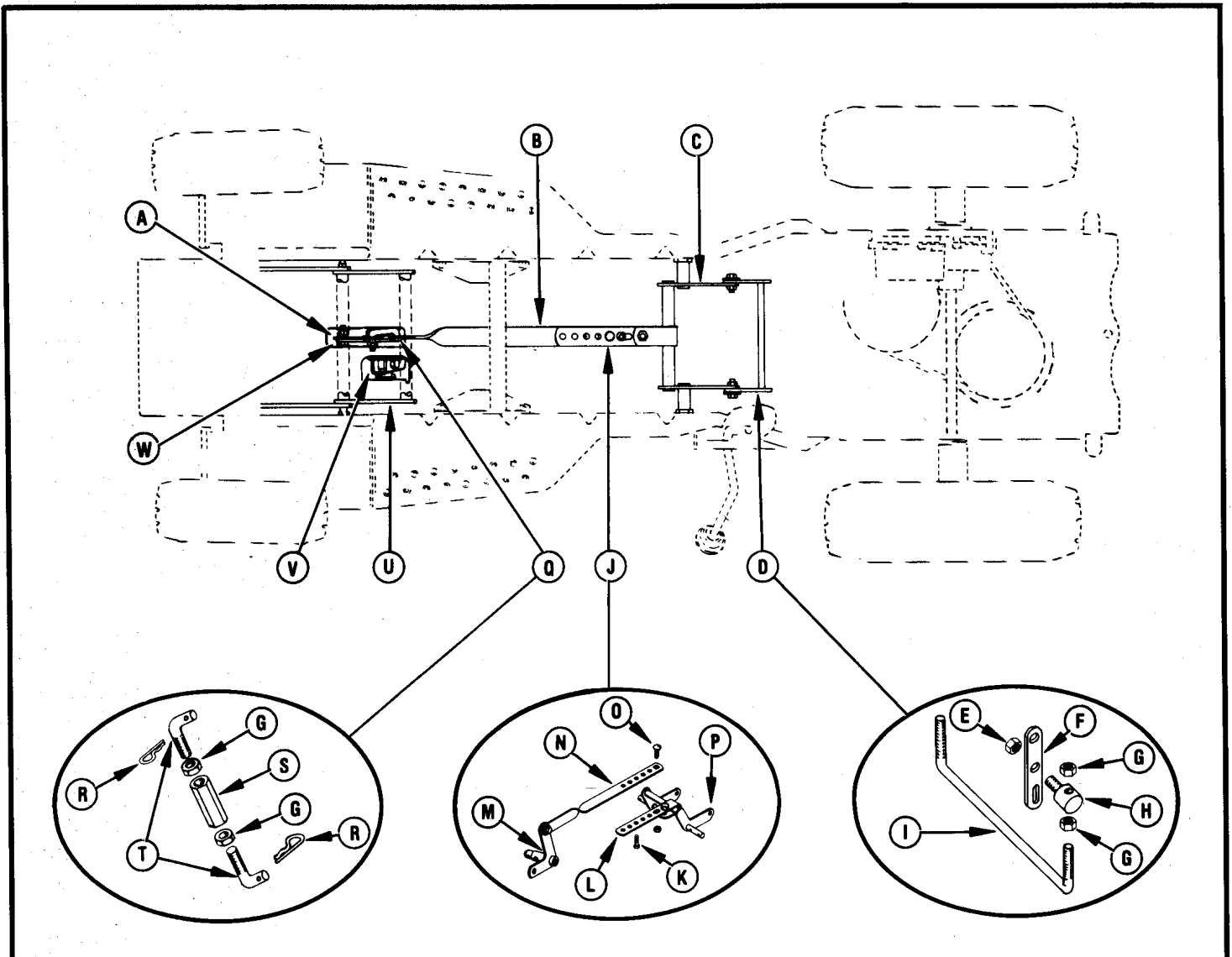

(A) STRAP

(B) MOWER LIFT LINK

(C) REAR MOWER HANGER

(D) REAR ADJUSTABLE LINK

(E) LOCKNUT

(F) REAR LIFT LINK

(G) JAM NUT

(H) ROD PIVOT

(I) REAR LIFT ROD

(J) ADJUSTABLE STRAP WITH ADJUSTMENT HOLES

(K) CAP SCREW

(L) ADJUSTMENT STRAP

(M) LIFT ARM

(N) LIFT STRAP

(O) CARRIAGE BOLT

(P) REAR MOWER HANGER

(Q) FRONT ADJUSTABLE LINK

(R) HAIRPIN

(S) COUPLING NUT

(T) FRONT LIFT LINK

(U) FRONT LIFT ARM (927001, 2, 4, 9, 10, 11, 14,
17, 18, 20, 21, 24, 25)

FRONT LIFT ARM (927005, 6, 7, 8, 12, 13, 15,
16, 23, 26)

(V) MOWER HEIGHT LEVER

(W) LIFT ARM

NOTE: REFER TO PM-27-83 FOR PART NUMBERS.

DIAGRAM D — 2

FUNCTIONAL SYSTEMS

STEERING SYSTEM

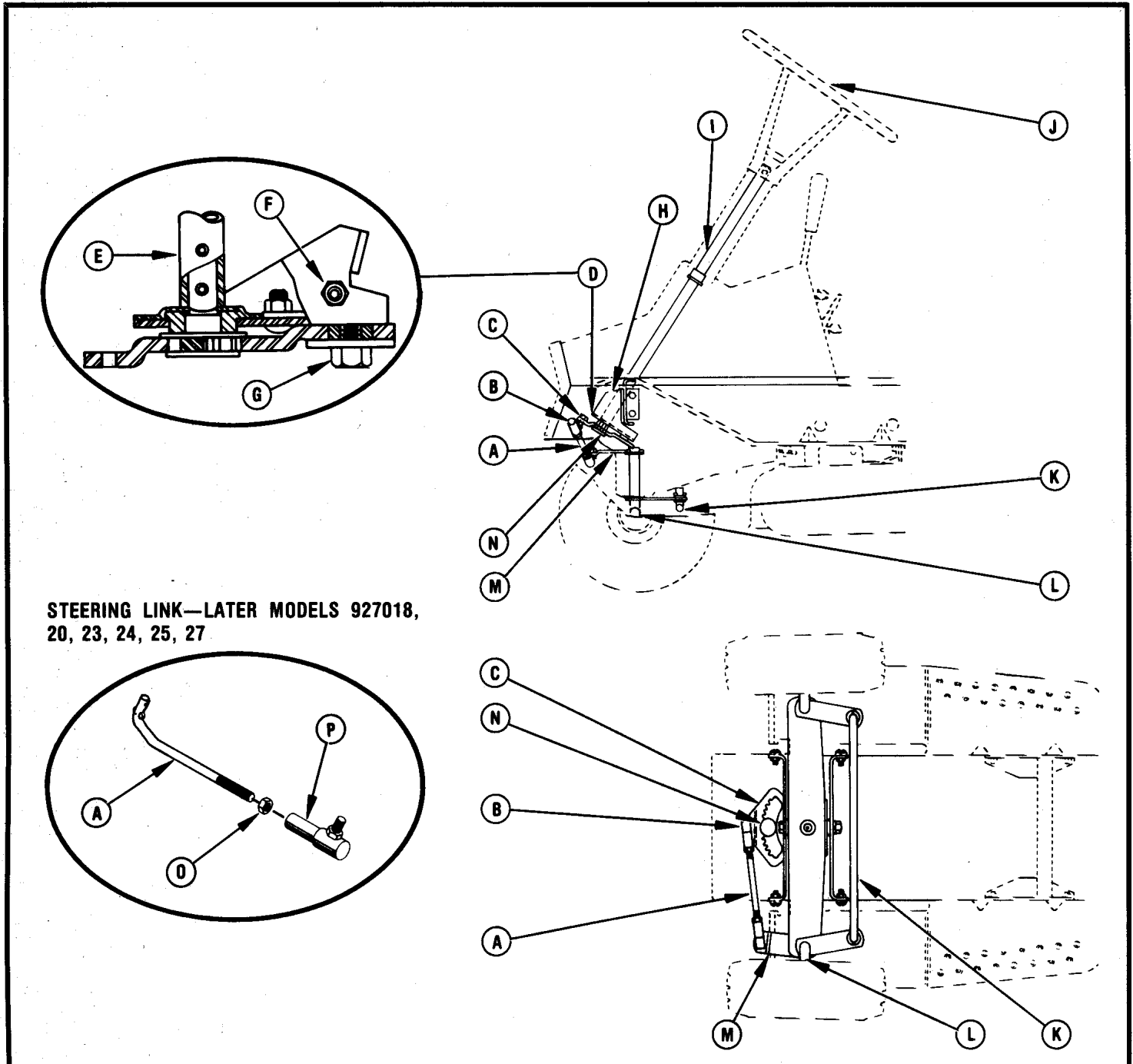

STEERING LINK—LATER MODELS 927018,
20, 23, 24, 25, 27

- (A) STEERING LINK (RM MODELS)
TIE ROD (SRM MODELS)
- (B) BALL JOINT (EXCEPT SRM MODELS)
- (C) STEERING GEAR
- (D) PINION AND STEERING ADJUSTMENT
- (E) BOTTOM OF STEERING POST
- (F) TURN TO ADJUST
- (G) LOOSEN NUT
- (H) STEERING BRACKET

- (I) STEERING SHAFT
- (J) STEERING WHEEL
- (K) TIE ROD
- (L) WHEEL SPINDLE, R.H. (027062)
WHEEL SPINDLE, L.H. (012102)
- (M) ARM
- (N) PINION
- (O) NUT, 3/8-24
- (P) BALL JOINT

NOTE: REFER TO PM-27-83 FOR PART NUMBERS.

DIAGRAM E

ELECTRICAL SYSTEMS

RIDING MOWER MODELS 927004, 6 AND 8

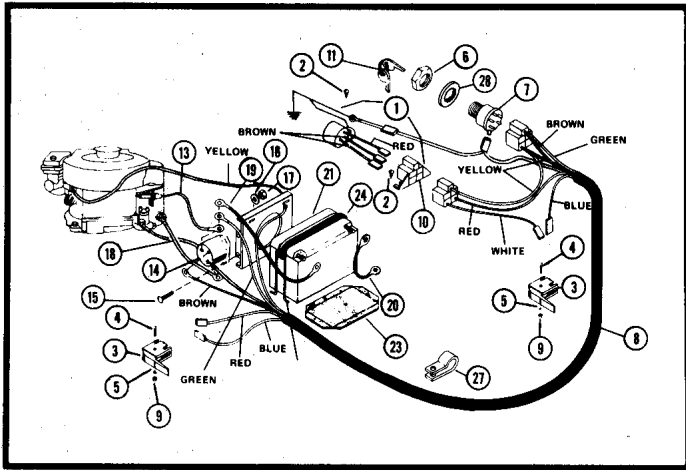

RIDING MOWER MODELS 927001, 2, 5, 7, 14

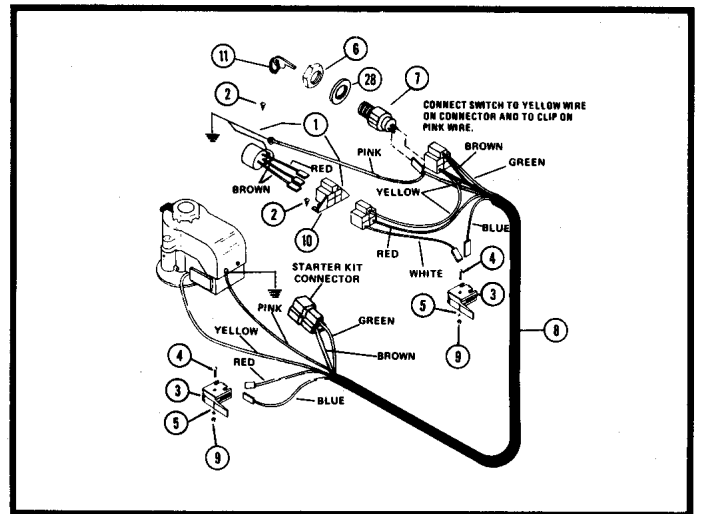

RIDING MOWER MODELS 927003, 9, 10, 12, 15, 21, 24 (SERIAL NO'S UP TO 005501) AND 26 WITH RECOIL START

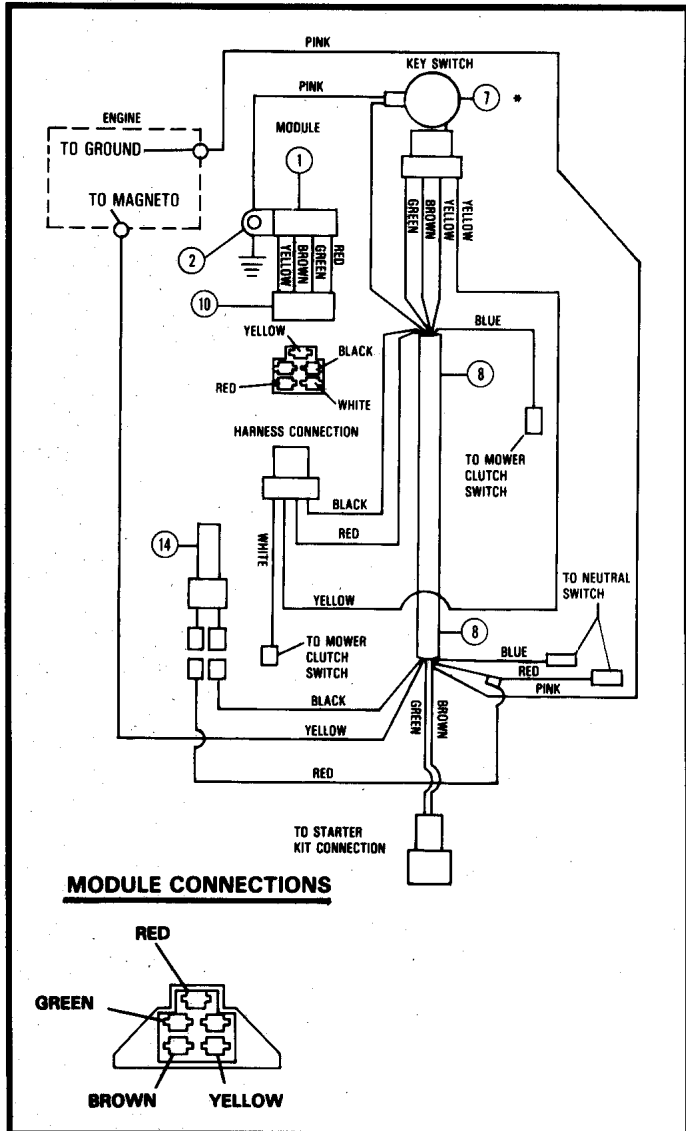

RIDING MOWER MODELS 927011, 13, 16 (ALL MODELS), 23 (SERIAL NO'S UP TO 002801), AND 25 (SERIAL NO'S UP TO 004001) WITH ELECTRIC START

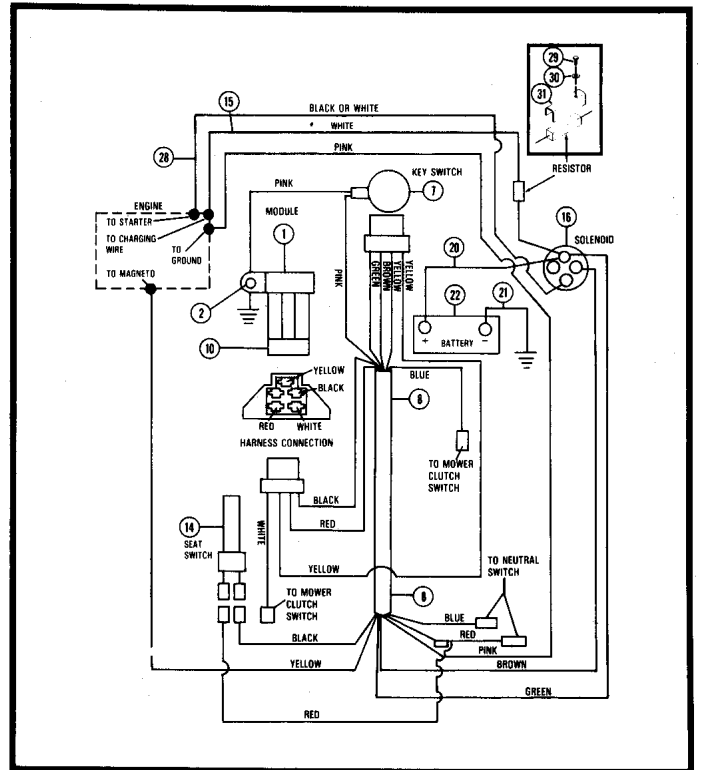

ELECTRICAL SYSTEMS

RIDING MOWER MODELS 927017 (ALL MODELS), 18 (SERIAL NO'S UP TO 001201), 20 (SERIAL NO'S UP TO 004500) WITH RECOIL START

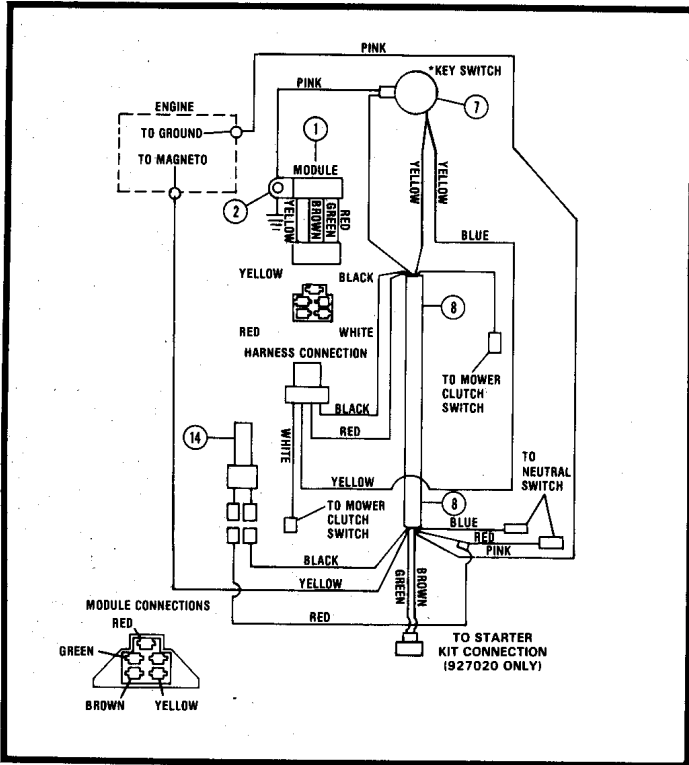

RIDING MOWER MODELS 927020 (SERIAL NO'S 004501 AND UP) AND 24 (SERIAL NO'S 005501 AND UP) WITH RECOIL START

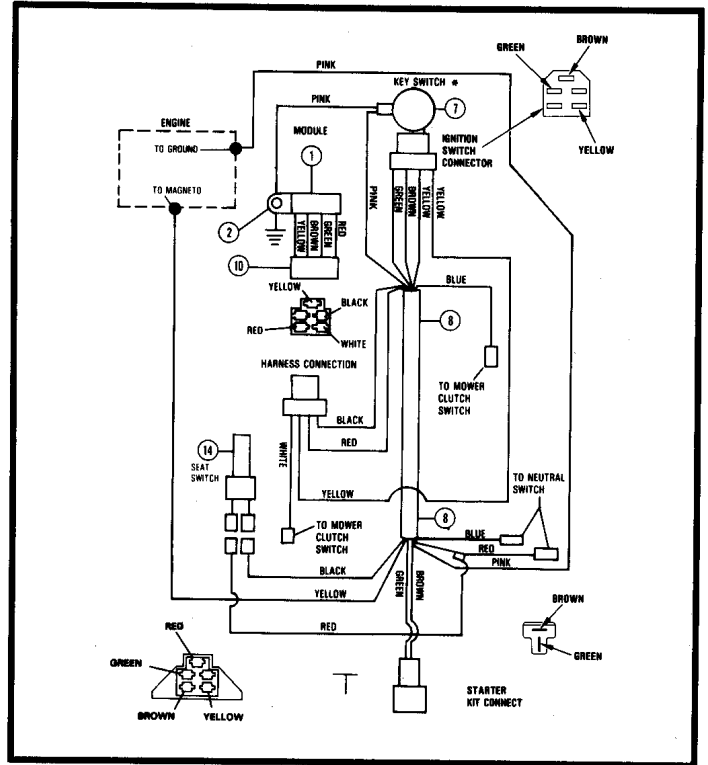

RIDING MOWER MODELS 927018 (SERIAL NO'S 001201 AND UP) AND 27 (ALL MODELS) WITH RECOIL START

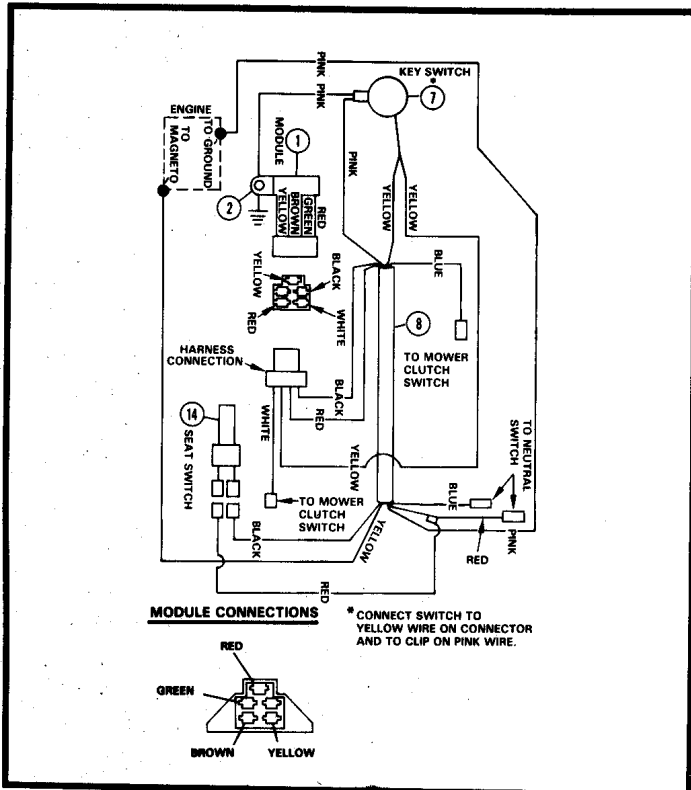

RIDING MOWER MODELS 927023 (SERIAL NO'S 002801 AND UP), AND 25 (SERIAL NO'S 004001 AND UP) WITH ELECTRIC START

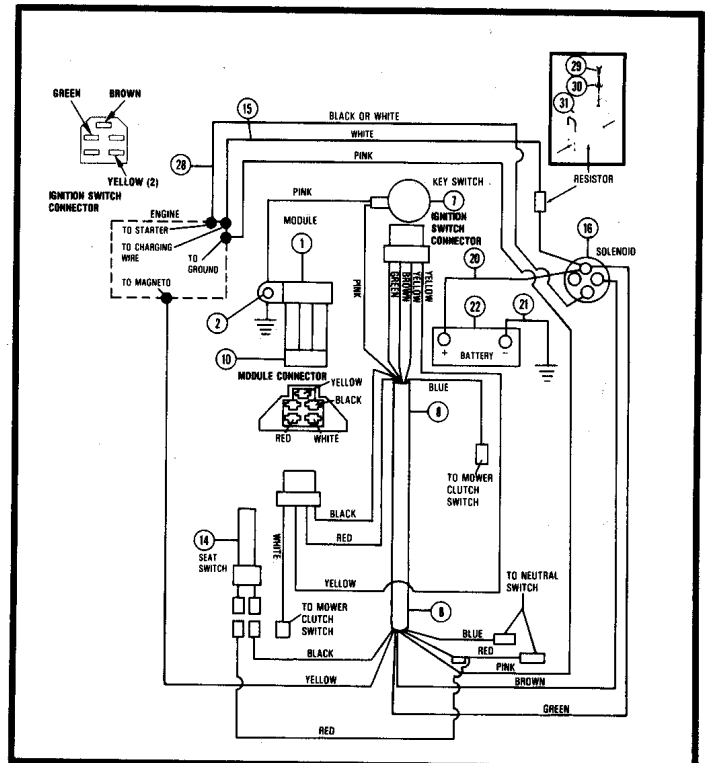

ELECTRICAL SYSTEMS

RIDING MOWER MODELS 927003, 9, 10, 12, 15, 21, 24, 26

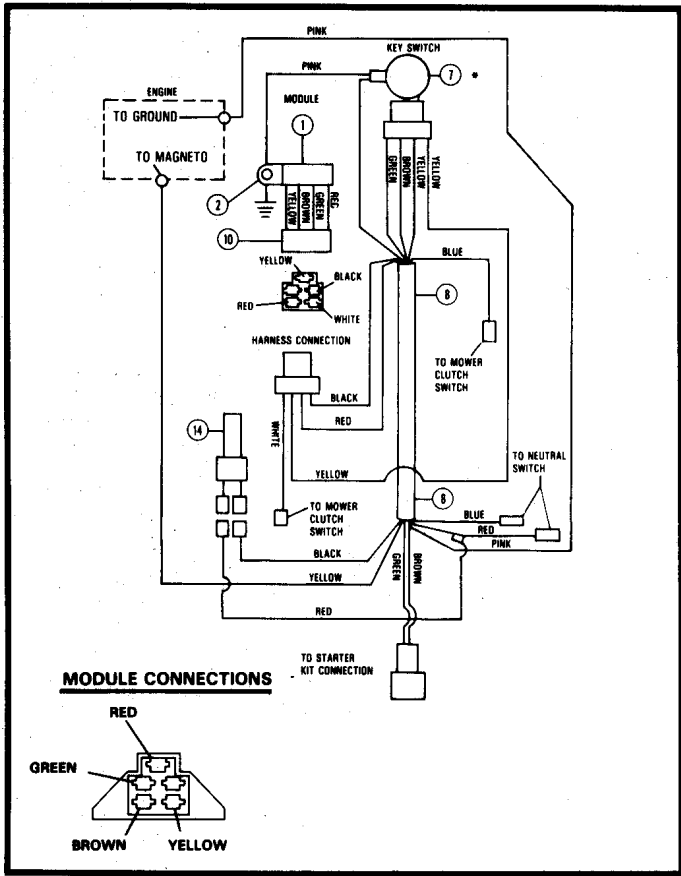

RIDING MOWER MODELS 927020 (SERIAL NO'S 004501 AND UP), AND 24 (SERIAL NO'S 005501 AND UP)

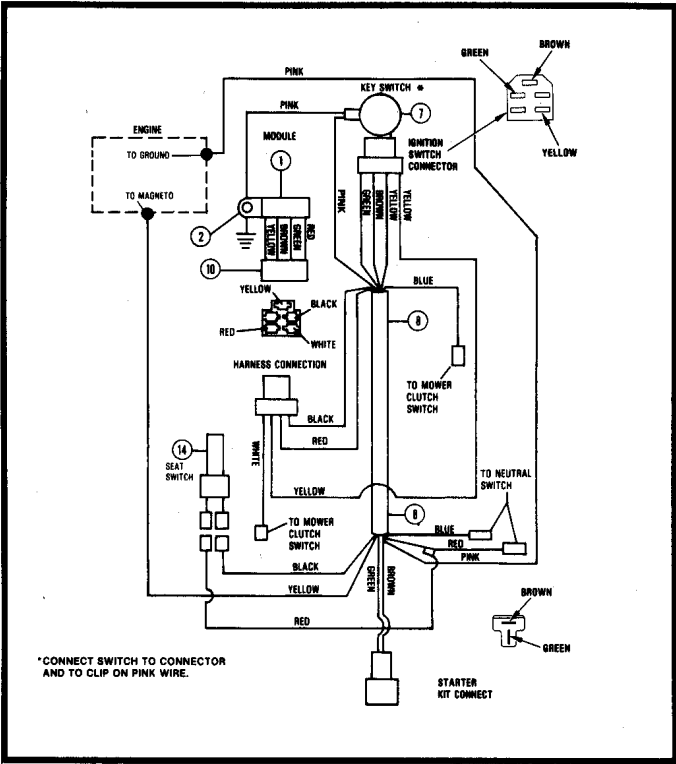

RIDING MOWER MODELS 927011, 13, 16, 23, 25 WITH ELECTRIC START

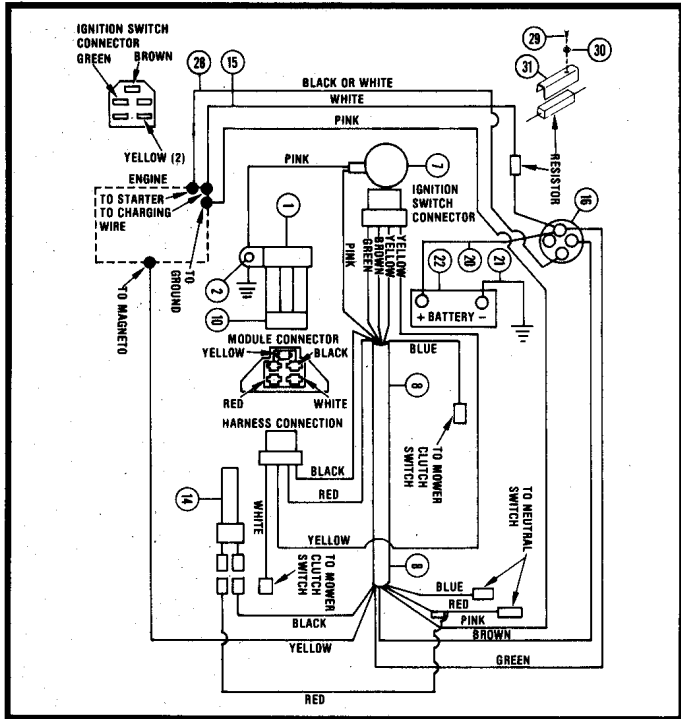

ADJUSTMENTS/MAINTENANCE

MODELS WITH SERVICE BAR:



CAUTION: WHEN MAKING ANY ADJUSTMENT OR REPAIRS REMOVE SPARK PLUG WIRE. TO AVOID SPILLING BATTERY ACID OR GASOLINE WHEN MAKING REPAIRS OR ADJUSTMENTS REQUIRING ACCESS TO THE BOTTOM OF THE TRACTOR, BE SURE TO REMOVE THE BATTERY AND DRAIN THE GAS TANK BEFORE TIPPING TRACTOR ONTO SERVICE BAR. DRAIN GAS TANK BY REMOVING FUEL LINE AT CARBURETOR OR FUEL TANK, WHICHEVER IS EASIER. AFTER FUEL TANK IS DRAINED, RUN ENGINE TO REMOVE REMAINING FUEL IN CARBURETOR. REMOVE AIR CLEANER ELEMENT. FAILURE TO FOLLOW THESE PRECAUTIONS WILL RESULT IN THE AIR CLEANER ELEMENT BECOMING SOAKED WITH FUEL, PICKING UP DIRT AND CHOKING THE ENGINE. THE GASOLINE DRAWN INTO THE CYLINDER AND WASHING THE CYLINDER WALLS WILL ALSO SHORTEN ENGINE LIFE.

MODELS 927017, 18 and 20 ONLY (MODELS WITHOUT SERVICE BAR):



IMPORTANT: RAMPS AND/OR BLOCKS MAY BE USED FOR RAISING RIDING MOWER WHEN PERFORMING UNDERSIDE ADJUSTMENTS. BE SURE UNIT IS PROPERLY SECURED AND SUPPORTED TO PREVENT FALLING, TIPPING, OR DANGER TO OPERATOR. IN SOME SITUATIONS IT WILL BE NECESSARY TO REMOVE THE MOWER PAN AS FOLLOWS:

1. LOWER MOWER PAN WITH MOWER HEIGHT LEVER.
2. DISCONNECT FRONT LINKS BY REMOVING HAIRPINS.
3. PLACE MOWER CLUTCH LEVER IN "OUT" POSITION. REMOVE MOWER BELT BY ROLLING IT OFF OF THE MOWER SHEAVE (AT TOP OF MOWER PAN).
4. DISCONNECT REAR LINK BY REMOVING HAIRPIN AND PULLING PIN OUT OF SWIVEL BRACKET.
5. BE SURE TO CHECK MOWER BELT FINGER FOR EVEN SPACING AROUND BELT WHEN RE-INSTALLING MOWER PAN.



CAUTION: WHEN ADJUSTING, REPLACING, OR MOVING THE MOWER BLADE OR DRIVE BELT, THE KEY SHOULD BE REMOVED FROM KEY SWITCH AND THE SPARK PLUG WIRE DISCONNECTED TO PREVENT ACCIDENTAL STARTING.



CAUTION: IF RIDING MOWER IS TIPPED, GASOLINE MAY SOAK THE AIR CLEANER (POSSIBLY RESULTING IN DIRT BUILD-UP WHICH CAN CAUSE CHOKE-UP OF THE ENGINE) AND ENTER CYLINDER (POSSIBLY WASHING CYLINDER WALLS WHICH CAN SHORTEN ENGINE LIFE). IF, FOR ANY REASON, RIDING MOWER MUST BE TIPPED OR LIFTED BE SURE TO DRAIN FUEL FROM ENGINE AND SHUT OFF FUEL FROM FUEL TANK. FOLLOW ENGINE MANUFACTURER'S INSTRUCTIONS. AVOID SPILLED GASOLINE BY DRAINING FUEL TANK.

SEAT ADJUSTMENT

All seats are adjusted by loosening four bolts under the seat and sliding the seat to the desired position. Retighten the bolts. Check to see that seat switch still functions properly. Refer to "INTERLOCK SYSTEM" instructions in "ASSEMBLY AND PRE-SERVICE" section of this manual.

SEAT MAINTENANCE

Clean the seat regularly, using a vinyl cleaner (not a solvent). Extreme temperatures can damage the seat when left without protection against weather. If the seat should tear, apply vinyl repair tape to the damaged area.

CLUTCH AND BRAKE ADJUSTMENT — FIGURES 1-1, 1-2, AND DIAGRAMS A AND B

The Clutch and Brake adjustments are dependent upon each other. The Clutch must be adjusted first as follows:

1. Tip Riding Mower onto the service bar to provide access to the underside.

NOTE: REMOVE BATTERY AND DRAIN GAS TANK FOLLOWING THE "CAUTION" INSTRUCTIONS AT THE BEGINNING OF THIS "ADJUSTMENTS-MAINTENANCE" SECTION.

2. Place Speed Control Lever in "NEUTRAL".
3. Depress Clutch Pedal all the way down and engage the Parking Brake.
4. Adjust the double nuts on the clutch rod until the carrier yoke clears the neutral stop by 1/8" to 1/4". See Figure 1-1 and Diagram A.
5. Release the Parking Brake. Turn both rear wheels by hand. They should rotate freely in "NEUTRAL" position; not rotate in other positions. This completes the clutch adjustment.

ADJUSTMENTS/MAINTENANCE

CLUTCH AND BRAKE ADJUSTMENT (CONTINUED)

6. The Brake is engaged by depressing the Brake Pedal or by depressing the Clutch Pedal beyond the clutching range. The Brake may now be adjusted as follows:
 - a. With Speed Control Lever in "NEUTRAL", loosen the top band adjustment nut while turning the rear wheels. Use two 1/2" wrenches to free the locking nut without distorting the brake band. Tighten until the wheels just start to bind. Back off the adjusting nut 1-1/2 turns from this point. See Figure 1-2 and Diagram B.
 - b. Test the Brake function by operating the Clutch Pedal. Secure adjustment by tightening the locknut securely. The brake band should not twist.

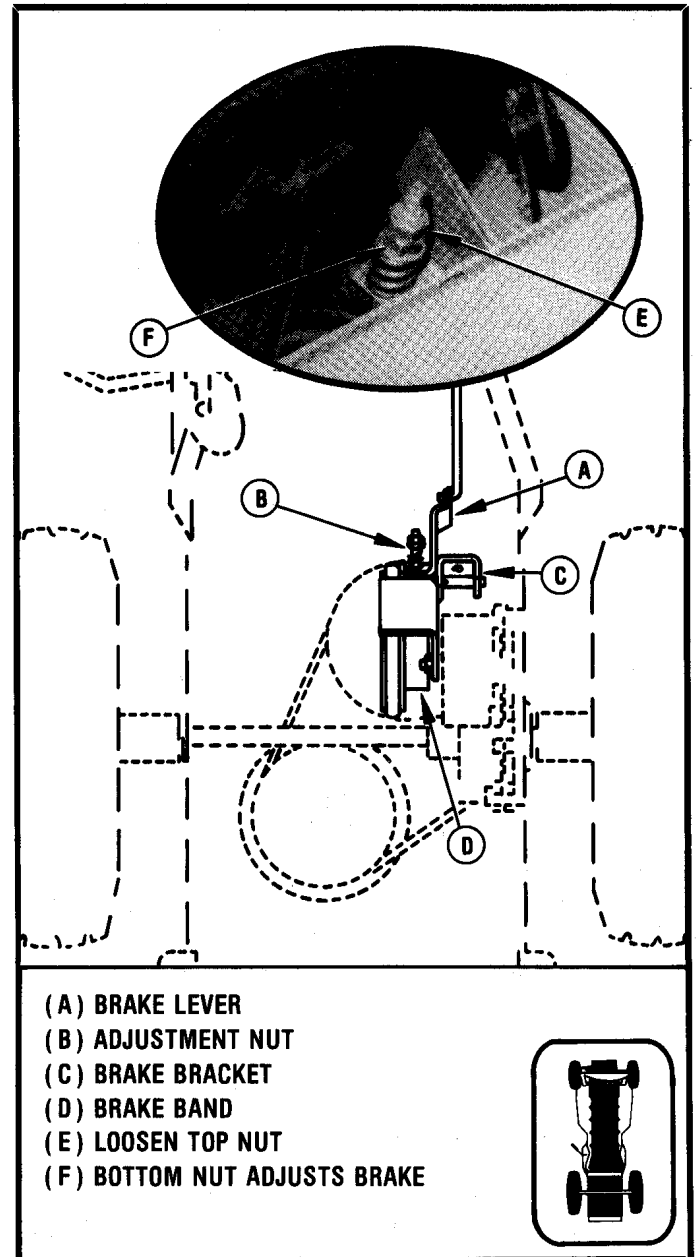
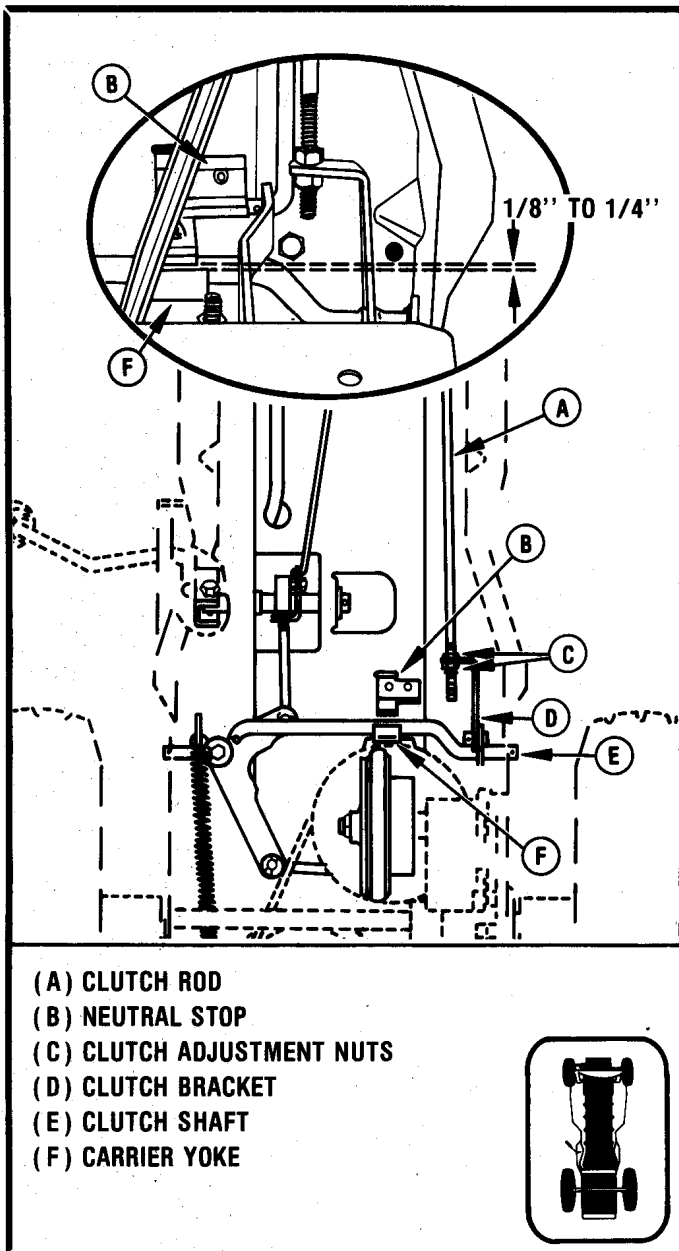

FIGURE 1-2

PINION AND STEERING ADJUSTMENT (EARLY MODELS) — FIGURES 1-3, 1-4 AND DIAGRAM E

Pinion is factory adjusted and should seldom require adjustment. If excessive play develops in the steering, adjust the spacing between the steering pinion and steering gear as follows:

1. Drain the fuel tank and remove the battery. Tip Riding Mower onto the service bar. See instructions at beginning of this section of manual.
2. Loosen the lower locknut (Figure 1-3) and tighten the adjustment nut until steering works smoothly and with no play.
3. Retighten the lower locknut.

ADJUSTMENTS/MAINTENANCE

PINION AND STEERING ADJUSTMENT (CONTINUED)

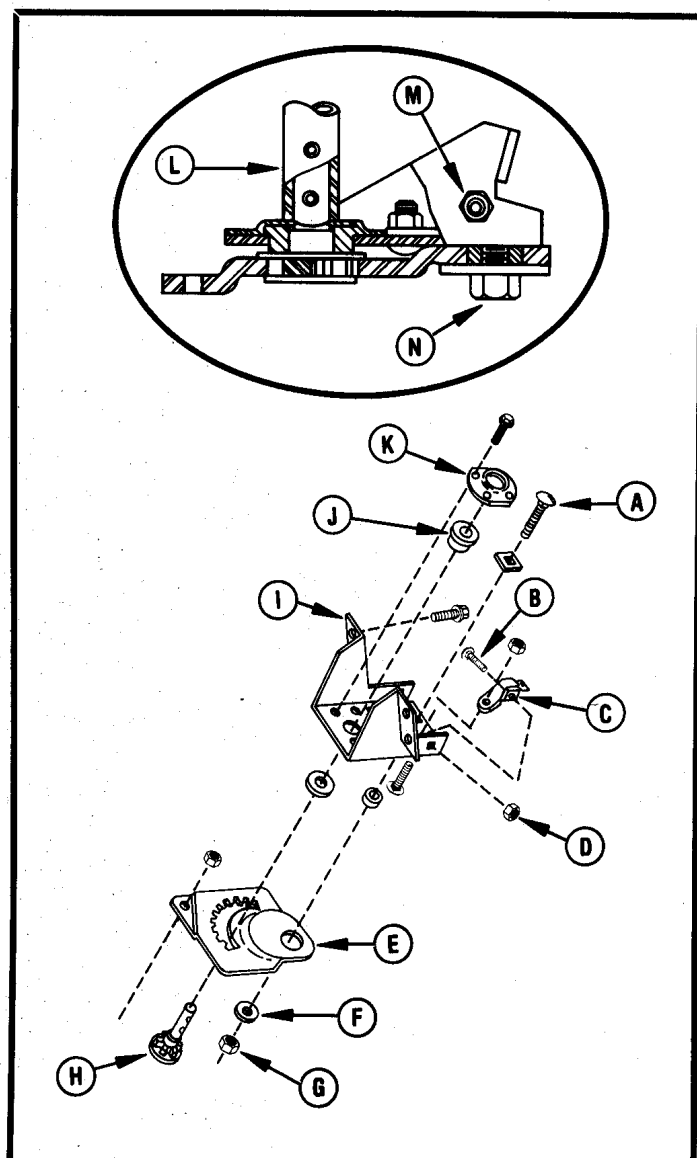

- (A) CARRIAGE BOLT
- (B) CARRIAGE BOLT
- (C) ADJUSTMENT BRACKET
- (D) LOCKNUT, 1/4-20
- (E) STEERING GEAR
- (F) WASHER
- (G) LOCKNUT, 3/8-16
- (H) PINION
- (I) STEERING BRACKET
- (J) FLANGE BUSHING
- (K) RETAINING PLATE
- (L) BOTTOM OF STEERING POST
- (M) TURN TO ADJUST
- (N) LOOSEN NUT

FIGURE 1-3

FRICION WHEEL STOP ADJUSTMENT AND REPLACEMENT — SEE FIGURE 1-4

NOTE: REMOVE BATTERY AND DRAIN GAS TANK FOLLOWING THE "CAUTION" INSTRUCTIONS AT THE BEGINNING OF THIS "ADJUSTMENTS-MAINTENANCE" SECTION.

1. Place Speed Control Lever in "NEUTRAL". Tip Riding Mower onto service bar.
2. Remove the friction wheel and guard by removing the five cap screws and lockwashers securing the friction wheel to the friction wheel hub.
3. Replace the guard on the hub and secure temporarily with two of the cap screws.
4. Place the Speed Control Lever in any "FORWARD" position.

NOTE: THE CLUTCH SHAFT STOP IS A CAP SCREW POSITIONED IN A SLOTTED HOLE IN THE RIGHT SIDE OF THE FRAME. THE CAP SCREW IS SECURED IN POSITION BY TWO HEX NUTS. THE ARM OF THE CLUTCH SHAFT IS HELD AGAINST THIS STOP BY THE PRESSURE OF THE CLUTCH SPRING.

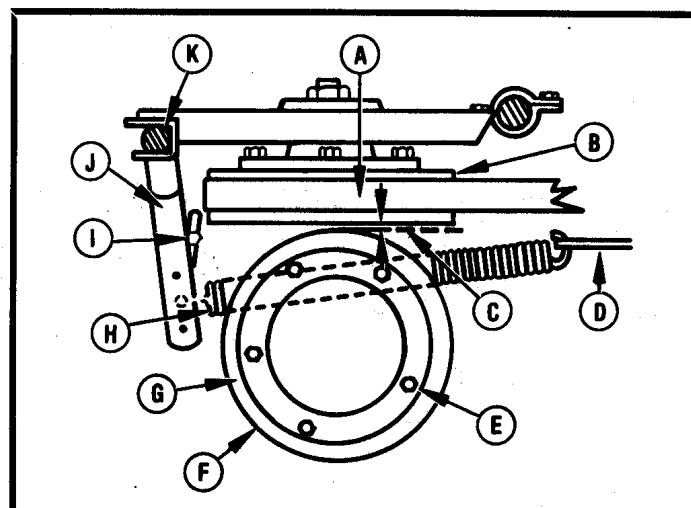

- (A) ARIENS DRIVE BELT (072112)
- (B) DRIVE DISC
- (C) SET FOR MINIMUM SPACE
- (D) IDLER ARM
- (E) FIVE CAP SCREWS, LOCKWASHERS
- (F) FRICTION WHEEL GUARD
- (G) FRICTION WHEEL
- (H) CLUTCH SPRING
- (I) CLUTCH SHAFT STOP
- (J) CLUTCH SHAFT ARM
- (K) CLUTCH SHAFT

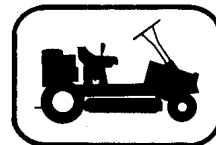

FIGURE 1-4

ADJUSTMENTS/MAINTENANCE

FRICION WHEEL STOP ADJUSTMENT AND REPLACEMENT (CONTINUED)

- Loosen the clutch shaft stop in its slot. With the clutch arm riding on the stop, position the stop in the slot in the position that gives the smallest distance between the guard and the drive disc. Secure stop in this position.
- Return the Speed Control Lever to "NEUTRAL".
- Replace the friction wheel and guard and secure with the five cap screws and lockwashers. Be sure friction wheel is located over shoulder of hub properly.
- Hook the clutch spring to the center hole in the clutch shaft arm.

NOTE: SEE "DRIVE PARTS PACKAGE" (527029) INSTRUCTIONS ON PAGE 59 OF THIS MANUAL FOR REPLACEMENT OF OLDER STYLE FRICTION DRIVE SYSTEM IF SO EQUIPPED.

MOWER PAN REMOVAL AND REPLACEMENT — FIGURE 1-5

NOTE: REMOVE BATTERY AND DRAIN GAS TANK FOLLOWING THE "CAUTION" INSTRUCTIONS AT THE BEGINNING OF THIS "ADJUSTMENTS-MAINTENANCE" SECTION.

- Place Mower Height Lever in "LOW" position and Mower Clutch Lever in the "OUT" position.
- Roll mower belt off mower sheave.
- Remove front and rear hanger pins; remove cotter pin and pull out the engagement link. Mower pan is now free from unit.

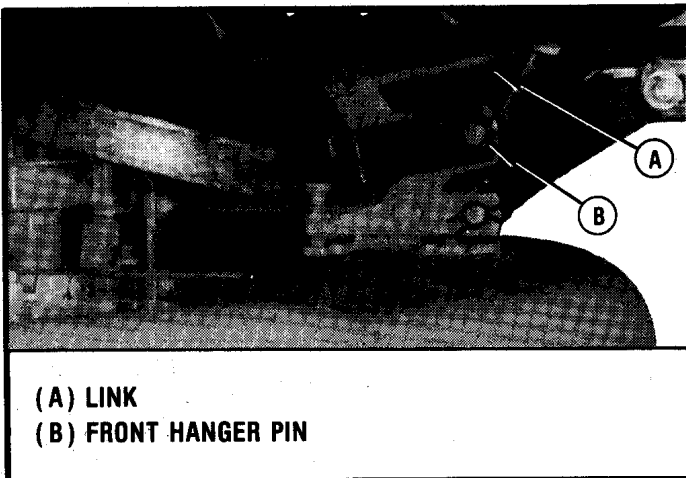

FIGURE 1-5

- To replace mower pan, reverse procedure.
- Check mower belt finger for even clearance.

NOTE: TO REMOVE THE 32" MOWER PAN FOLLOW INSTRUCTIONS BELOW AND REFER TO PARTS MANUAL.

- Remove rear belt finger and slip belt off engine sheave.
- Disconnect clutch rod at front of rod.
- Remove hairpin and "L" shaped pin at back of mower pan.
- Remove front hanger pin.
- Pivot mower down on positioning arms.
- Pull out hairpins that retain positioning arms to pan bracket and slip arms off pins.

MOWER BELT REMOVAL AND REPLACEMENT — FIGURE 1-6

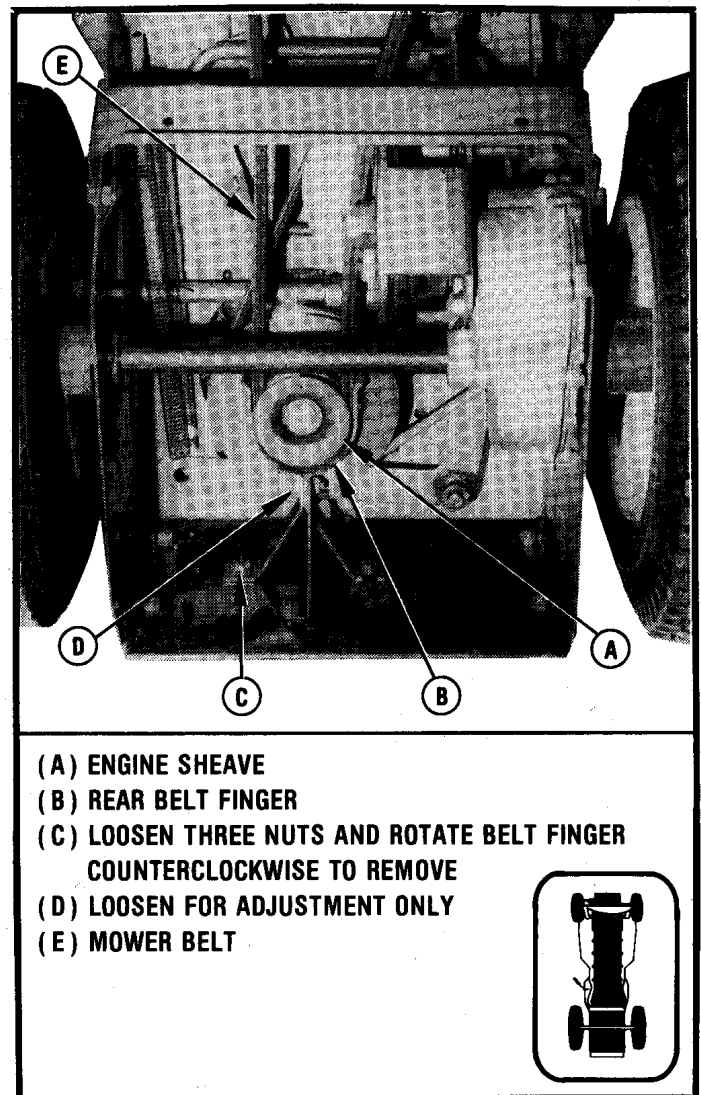

FIGURE 1-6

ADJUSTMENTS/MAINTENANCE

MOWER BELT REMOVAL AND REPLACEMENT (CONTINUED)

NOTE: REMOVE BATTERY AND DRAIN GAS TANK FOLLOWING THE "CAUTION" INSTRUCTIONS AT THE BEGINNING OF THIS "ADJUSTMENTS-MAINTENANCE" SECTION.

1. Tip Riding Mower onto service bar.
2. Place Mower Clutch Lever in the "OUT" position.
3. Loosen three nuts holding rear belt finger and rotate belt finger free. See Figure 1-6.
4. Roll belt free at mower sheave and remove.
5. To replace belt, thread belt over rear mower hanger and onto mower sheave. See Diagrams C and D.
6. Rotate belt around engine sheave.
7. Check mower belt finger.
8. To replace the rear belt finger, tighten the top two nuts first, then the bottom nut. In the event belt finger needs adjustment, loosen the nut just below the engine sheave (Figure 1-6), then reposition and tighten nut. There should be about 1/16" between belt finger and belt. Adjust mower belt.

NOTE: TO REMOVE THE 32" MOWER BELT FOLLOW INSTRUCTIONS BELOW AND REFER TO PARTS MANUAL.

1. Tip Riding Mower onto service bar.
2. Remove rear belt finger and mower sheave belt finger.
3. Loosen the idler mounting bolts on the idler arm and the idler mount.
4. Remove mower belt.
5. Thread new belt into position.
6. Tighten the mounting bolt on the "V" idler making sure that the hole in the belt finger is engaged on the tab on the idler mount.
7. Adjust the belt finger on the flat idler to provide 1/8" clearance between the belt and the belt finger and tighten the mounting bolt.
8. Replace the belt finger at mower sheave and make sure there is at least 1/16" clearance between the sheave and the belt finger. Bend the belt finger if necessary.
9. Place the belt on the engine sheave and engage the Mower Clutch to hold the belt in place while installing the rear belt finger. Make sure that there is 1/8" clearance between the belt and belt fingers on both sides of the engine sheave. Bend the belt fingers if necessary.

NOTE: WHEN REPLACING BELT BE SURE TO ADJUST THE BELT FINGER ON THE IDLER ARM TO PROVIDE 1/8" CLEARANCE BETWEEN BELT FINGER AND BELT WHEN DRIVE IS ENGAGED.

DRIVE BELT REMOVAL AND REPLACEMENT

NOTE: REMOVE BATTERY AND DRAIN GAS TANK FOLLOWING THE "CAUTION" INSTRUCTIONS AT THE BEGINNING OF THIS "ADJUSTMENTS-MAINTENANCE" SECTION.

1. Place Speed Control Lever in "NEUTRAL".
2. Tip the tractor onto service bar.
3. Remove engine sheave belt fingers. See Figure 1-6.
4. Rotate the mower belt free of the engine sheave.
5. Release drive belt from idler. See Figure 1-6.
6. Remove friction wheel. See Repair Manual section on this procedure. Remove belt.
7. Replace belt and thread around the engine sheave and then around the drive disc. Be sure belt is properly seated in sheaves.
8. Thread belt around idler.
9. Replace friction wheel, mower belt and rear belt fingers. See Repair Manual sections on these procedures.

MOWER BELT ADJUSTMENT — FIGURE 1-7

NOTE: THE MOWER BELT TENDS TO STRETCH DURING THE FIRST FEW HOURS OF OPERATION. ARIENS RECOMMENDS THAT THE TENSION ON THE BELT BE RE-ADJUSTED AFTER THE FIRST FIVE HOURS OF OPERATION. RE-ADJUST THE BELT FOLLOWING THE INSTRUCTIONS BELOW.

Place Mower Height Lever in the mid-notch position. Tighten belt just enough to prevent slippage under load. To accomplish this, use a 3/4" socket wrench to tighten the cap screw secured to the adjustment yoke at the front of the Riding Mower. See Figure 1-7. While tightening the cap screw hold the Mower Clutch Lever so that the front edge of the lever is positioned in line with the rear edge of the forward notch of the quadrant. Look through the slot in the left side of the cowl to see this. Belt engagement should occur with the lever at this point. The lever will pull slightly rear-ward from this point when tension has been sufficiently adjusted. Full locked-in engagement occurs when lever is positioned completely into the front notch of the quadrant. An effort should be required to move lever into this point. Over-tightening belt will cause premature belt and bearing wear. Belt must be re-adjusted if cutting in lowest cutting position.

ADJUSTMENTS/MAINTENANCE

MOWER BELT ADJUSTMENT (CONTINUED)

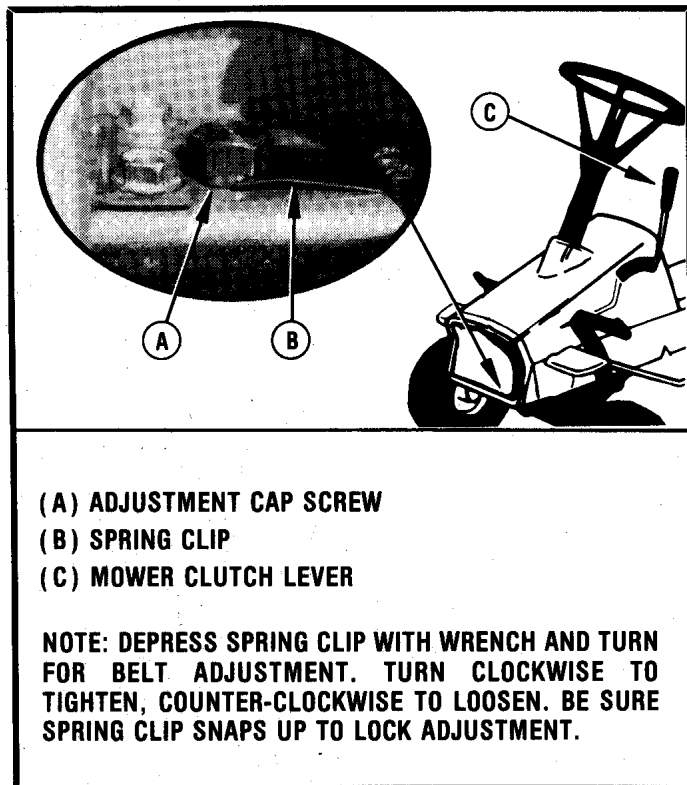

FIGURE 1-7

32" MOWER BELT FINGER ADJUSTMENT — FIGURE 1-8

Mower belt slippage may be caused by an incorrectly adjusted belt finger. The belt finger may be adjusted up against mower belt resulting in belt becoming pinched between belt finger and the idler.

Re-adjust belt finger in slot to clear belt by approximately 1/8"
See Figure 1-8.

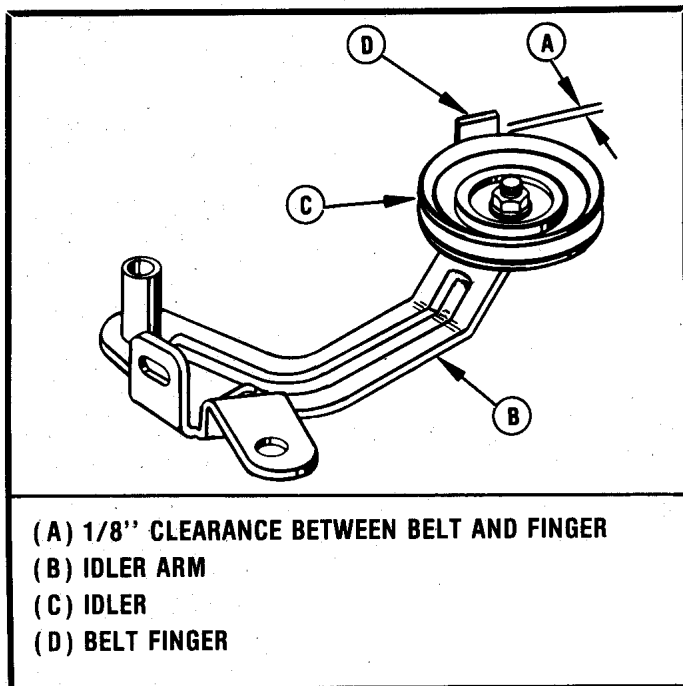

FIGURE 1-8

MOWER PERFORMANCE — FIGURES 1-9, 1-10 AND 1-11

Check tire pressure. See Figure 4-3. Uneven tire pressure may cause uneven grass cutting.

NOTE: SEE "RIDING MOWER PERFORMANCE GUIDE" SECTION FOR SPECIFIC INFORMATION ON HIGH PERFORMANCE ACCESSORIES.

All models are equipped with high lift blades standard. Vanes may be bolted to the blades to improve discharge and bagging or collecting of grass. These vanes may or may not be helpful depending on your type of grass and cutting conditions. See Figure 1-11.

Routinely check for wear on the mower blade and vanes, if used. This is especially true in sandy soil conditions.



CAUTION: WEAR OF THE MOWER BLADE CAN CAUSE STRUCTURAL WEAKNESS. DO NOT INSTALL NEW OR REPLACEMENT VANES ON WORN BLADES. THIS IS A POTENTIAL HAZARD.

NOTE: IF RIDING MOWER IS EQUIPPED WITH MOWER PAN FLANGES MAKE SURE ALL HARDWARE IS TIGHT AND THERE IS AT LEAST 1/4" CLEARANCE BETWEEN MOWER BLADE AND TOP OF FLANGE THROUGHOUT THE 360° BLADE TRAVEL. IF THERE IS INSUFFICIENT CLEARANCE, A NEW RETAINER HUB (031946), SUPPLIED WITH THE HIGH PERFORMANCE SERVICE ASSEMBLIES, IS AVAILABLE FOR INSTALLATION WITH NEW MODEL RIDING MOWER BLADES (WITH LARGE BLADE TRAY) OR HIGH PERFORMANCE SERVICE ASSEMBLIES BLADES.

Ariens recommends that the user try the mower without vanes first. If the performance is satisfactory, use without vanes since the vanes use more power and generate more noise. Use vanes only if satisfactory performance cannot be obtained without them. Generally, broadleaf grasses can be cut and bagged without vanes. The finer grasses may require vanes. Vanes may also be of help in extremely wet conditions.

Replace worn parts with Ariens original equipment, blade, vanes, and Grade 8 hardware as specified. Cap screws must be installed with heads on top of the vanes and vanes on top of blade. See Figure 1-11.

IMPORTANT: THE VANES (SERVICE PART NO. 527011) MUST BE USED IN PAIRS. THEY CANNOT BE INTERCHANGED WITH DIFFERENT OR WORN VANES ON THE SAME BLADE. USING ONE OF EACH OF A DIFFERENT TYPE OR WORN VANE WILL CAUSE THE BLADE TO BE OUT OF BALANCE AND SEVERE VIBRATION WILL OCCUR. EVEN WEAR ON THE PARTS AND PROPER BALANCE IS ENSURED BY REPLACING VANES IN PAIRS.

ADJUSTMENTS/MAINTENANCE

MOWER PERFORMANCE (CONTINUED)

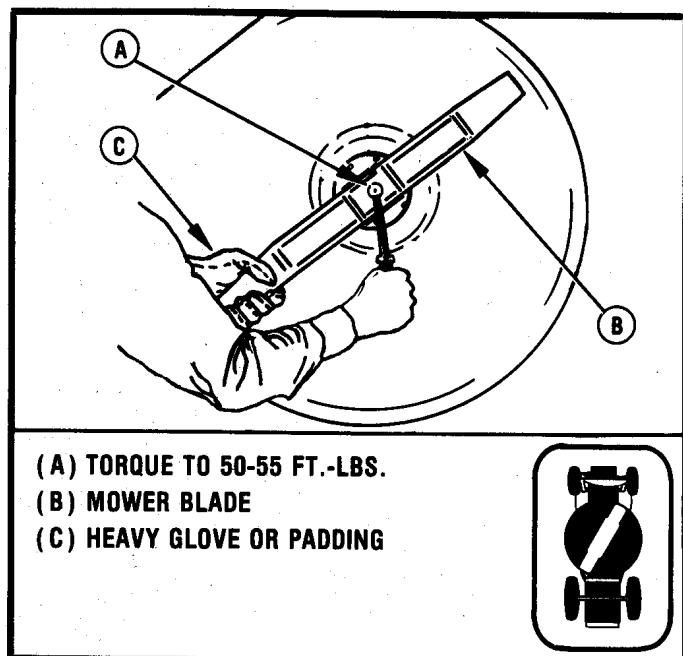

FIGURE 1-9

The mower blade should always be kept sharp and properly balanced. Disconnect spark plug wire. Stand mower up on service bar. Be sure it is firmly supported on a level surface. Use a heavy glove or padding for hand protection while removing mower blade. Remove the nut and lockwasher securing the blade and remove blade. See Figure 1-9.

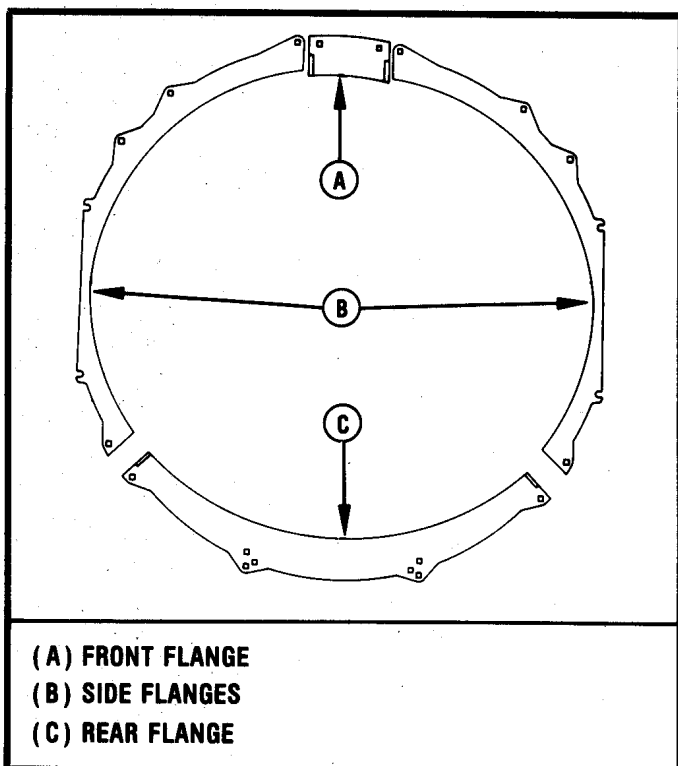

FIGURE 1-10

Sharpen blade by following the same contour of the cutting edge; be careful not to round off the outer corners of cutting edge.

Sharpen both cutting edges equally to keep the blade balanced.

Replace the mower blade in position on mower and secure with lockwasher and nut. Torque to 50-55 ft.-lbs. Be sure to use a heavy glove or padding for hand protection while fastening blade.

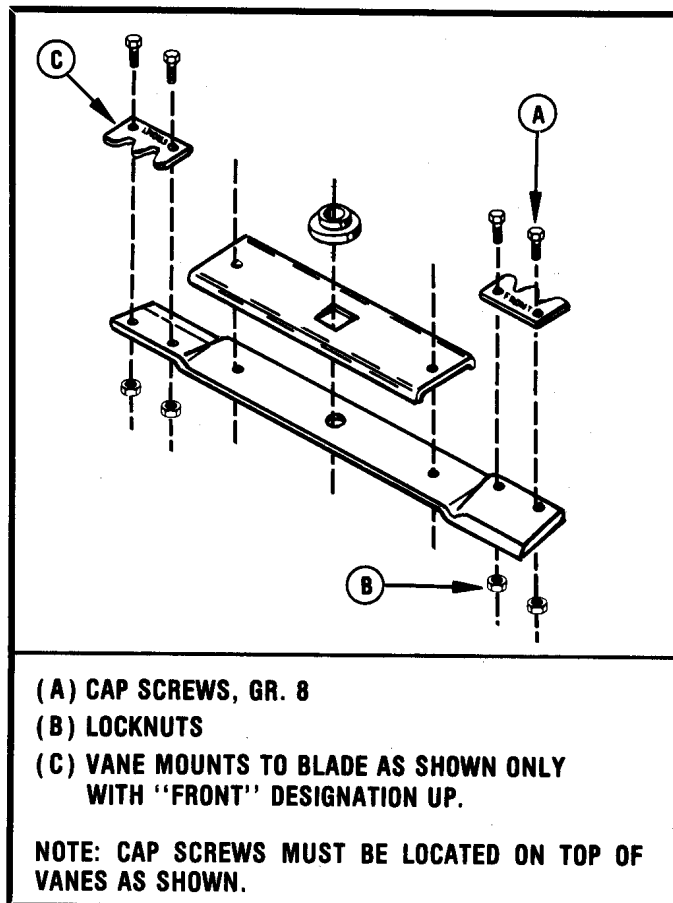

FIGURE 1-11

MOWER CUTTING HEIGHT AND BLADE PITCH MEASUREMENT

NOTE: BEFORE MEASURING HEIGHT AND PITCH SET RIDING MOWER ON A COMPLETELY FLAT, HARD SURFACE. BE SURE TIRE PRESSURES ARE SET TO 12 PSI FOR ALL PNEUMATIC TIRES.

Proceed with the following steps to check the cutting height and blade pitch for your grass conditions and requirements.

1. Normally, a range of approximately 1" to 4" of cutting height is possible. You may adjust this with the new lift link assemblies as described in the following "ADJUSTMENT PROCEDURES" section. In order to check your cutting height, measure the distance from the ground level to the cutting tip of the mower blade with the blade tip at the

ADJUSTMENTS/MAINTENANCE

MOWER CUTTING HEIGHT AND BLADE PITCH MEASUREMENT (CONTINUED)

discharge opening. See Figure 1-12. Rotate the blade using a glove or padding with the Mower Clutch disengaged "OUT" and check with the Mower Height Lever in either the highest or lowest position.

- In all cases, for proper grass cutting, the mower blade pitch must be maintained at a difference of 1/4" to 3/8" between the blade tip at front and blade tip at rear. The front dimension must be 1/4" to 3/8" lower than the rear.

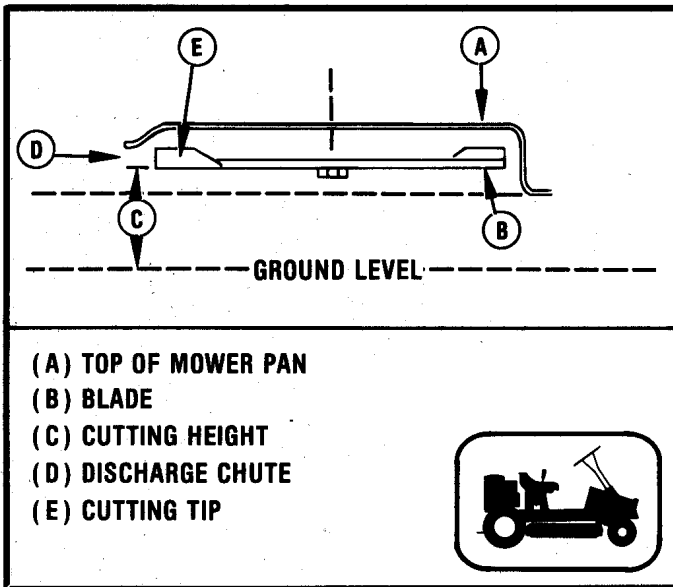

FIGURE 1-12

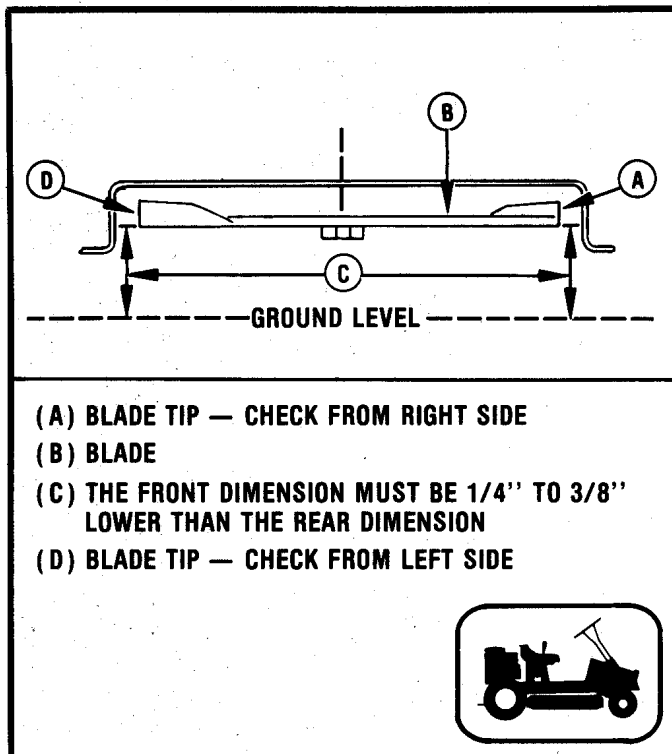

FIGURE 1-13

To measure the blade pitch put Mower Clutch in disengaged "OUT" position and Mower Height Lever in highest position. Rotate the blade, using a glove or heavy padding to protect your hand, so that the cutting tips of the blade are at center front and center rear of the mower. Engage Mower Clutch "IN" position and mark front tip of the blade with a piece of chalk or tape. Measure distance from ground level to blade tip as shown in Figure 1-13, for front. Disengage Mower Clutch and rotate blade 180° so that marked tip is now at center rear of mower. Measure the distance from ground level to the cutting tip at rear. See Figure 1-13. Compare the dimensions to determine if the front dimension is 1/4" to 3/8" lower than the rear. If this dimension difference (blade pitch) is not 1/4" to 3/8" lower for front, the pitch may be adjusted by following the instructions in the "ADJUSTMENT PROCEDURE" section.

MOWER CUTTING HEIGHT AND BLADE PITCH — ADJUSTMENT PROCEDURE



CAUTION: WHEN MAKING ANY ADJUSTMENT OR REPAIRS REMOVE SPARK PLUG WIRE. TO AVOID SPILLING BATTERY ACID OR GASOLINE WHEN MAKING REPAIRS OR ADJUSTMENTS REQUIRING ACCESS TO THE BOTTOM OF THE UNIT, BE SURE TO REMOVE THE BATTERY AND DRAIN THE GAS TANK BEFORE TIPPING TRACTOR ONTO SERVICE BAR. DRAIN GAS TANK BY REMOVING FUEL LINE AT CARBURETOR OR FUEL TANK, WHICHEVER IS EASIER. AFTER FUEL TANK IS DRAINED, RUN ENGINE TO REMOVE REMAINING FUEL IN CARBURETOR. REMOVE AIR CLEANER ELEMENT. FAILURE TO FOLLOW THESE PRECAUTIONS WILL RESULT IN THE AIR CLEANER ELEMENT BECOMING SOAKED WITH FUEL, PICKING UP DIRT AND CHOKING THE ENGINE. THE GASOLINE DRAWN INTO THE CYLINDER AND WASHING THE CYLINDER WALLS WILL ALSO SHORTEN ENGINE LIFE.

To adjust the cutting height refer to Steps 1 and 2 of following instructions only. To adjust the blade pitch refer to Steps 1, 2 and 3 and follow those instructions in that order. To achieve a proper balance of cutting height versus blade pitch, the operator must experiment to suit the grass conditions and ground surface variations. Remember, blade pitch, as described in "MEASUREMENT" section must be maintained. Keep a mental record of the settings on your Mower Height Lever to avoid cutting too high or too low (scalping on uneven surfaces).

STEP 1 — FRONT LIFT LINK ADJUSTMENT

NOTE: THIS ADJUSTMENT RAISES OR LOWERS THE FRONT OF THE MOWER, CHANGING MOWER HEIGHT AND PITCH: LATER MODELS OR MODELS WITH HEIGHT ADJUSTMENT SERVICE ASSEMBLY (527018) ONLY.

ADJUSTMENTS/MAINTENANCE

MOWER CUTTING HEIGHT AND BLADE PITCH — ADJUSTMENT (CONTINUED)

- a. After checking for the mower height and blade pitch, remove the front lift link assembly (627070) by removing the two hairpins securing it to the front lift arm and strap. See Figure 1-14.

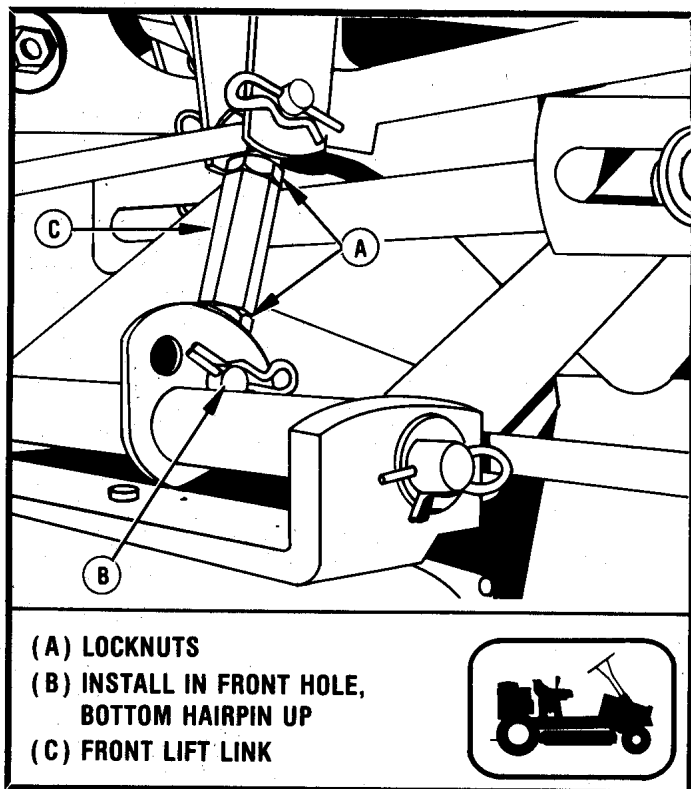

FIGURE 1-14

- b. Adjust the jam nuts to allow movement of the coupling nut. By turning the two front lift links (to maintain equal threading into the coupling nut) the length of the complete front lift link may be extended or decreased. See Figure 1-15. Turn links "IN" for shorter dimension to raise mower and mower blade. Turn "OUT" to lower.

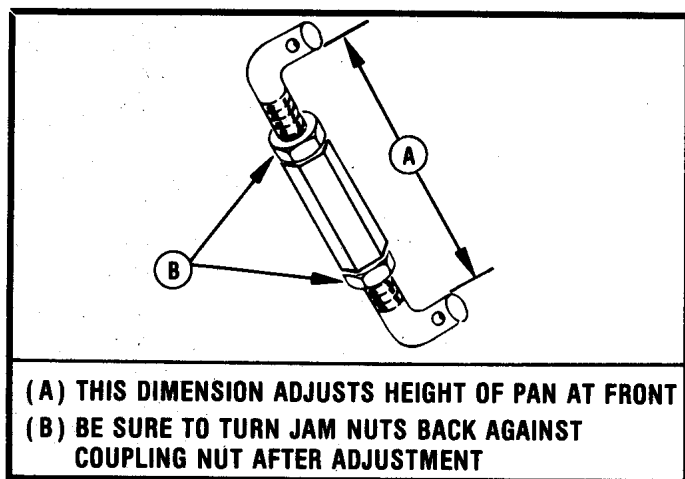

FIGURE 1-15

- c. After tightening jam nuts, replace the front lift link assembly.
d. Recheck the blade pitch and cutting height.

STEP 2 — REAR LIFT LINK ADJUSTMENT

NOTE: THIS ADJUSTMENT RAISES OR LOWERS THE BACK OF THE MOWER PAN CHANGING THE HEIGHT AND PITCH: LATER MODELS OR MODELS WITH HEIGHT ADJUSTMENT SERVICE ASSEMBLY (527018) ONLY

- a. After checking for the mower blade pitch, adjust the up or down movement of the threaded ends of the rear lift rod in the pivot by loosening the upper and lower jam nuts. Be sure to adjust each side of the assembly equally. Refer to Figure 1-16.

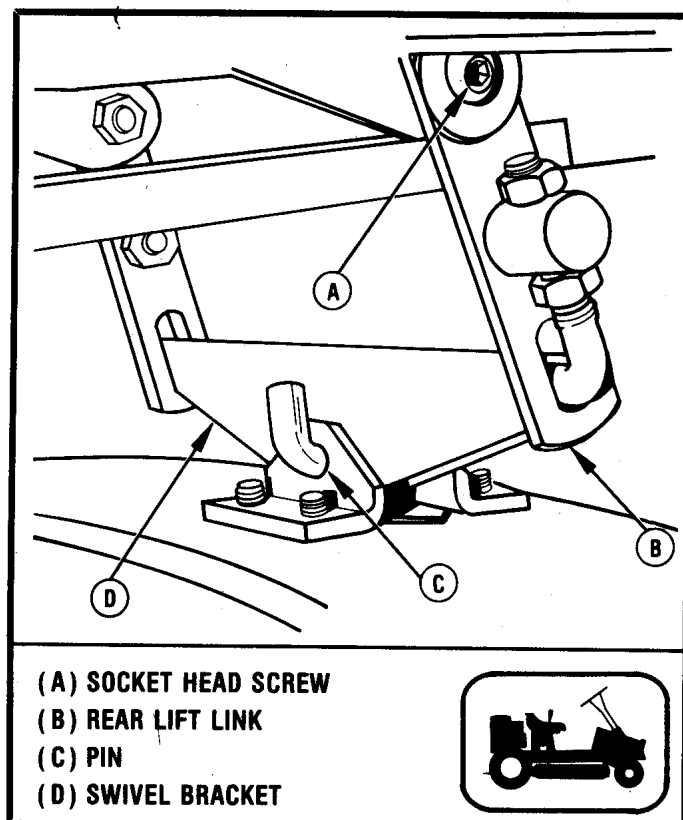

FIGURE 1-16

Retighten the jam nuts to secure the assembly together. Remember, blade pitch, as described in paragraph 2 of "MEASUREMENT" section, Page 30, must be maintained.

- b. Recheck the blade pitch and cutting height.

STEP 3 — ADJUSTMENT STRAP — FIGURE 1-17

NOTE: THIS ADJUSTMENT CHANGES THE PITCH OF THE PAN AND SHOULD BE USED IF PROPER ADJUSTMENT CAN NOT BE OBTAINED BY ADJUSTING THE FRONT AND REAR LIFT LINKS.

ADJUSTMENTS/MAINTENANCE

STEP 3 — ADJUSTMENT STRAP (CONTINUED)

- Following instructions in paragraph 2 of "MEASUREMENT" section, Page 30, measure from front blade tip to ground and rear blade tip to ground. Pitch is correct when the tip is 1/4" to 3/8" lower in front.
- If the measurement is not correct, loosen the carriage bolt, remove the 3/4" cap screw securing the lift strap and adjustment strap together; slide the lift strap and adjustment strap together (or apart) as required; and re-install the cap screw. The holes in the lift strap are tapped, and there are five holes in both straps to provide proper adjustment.
- Recheck the blade measurements and correct as required.

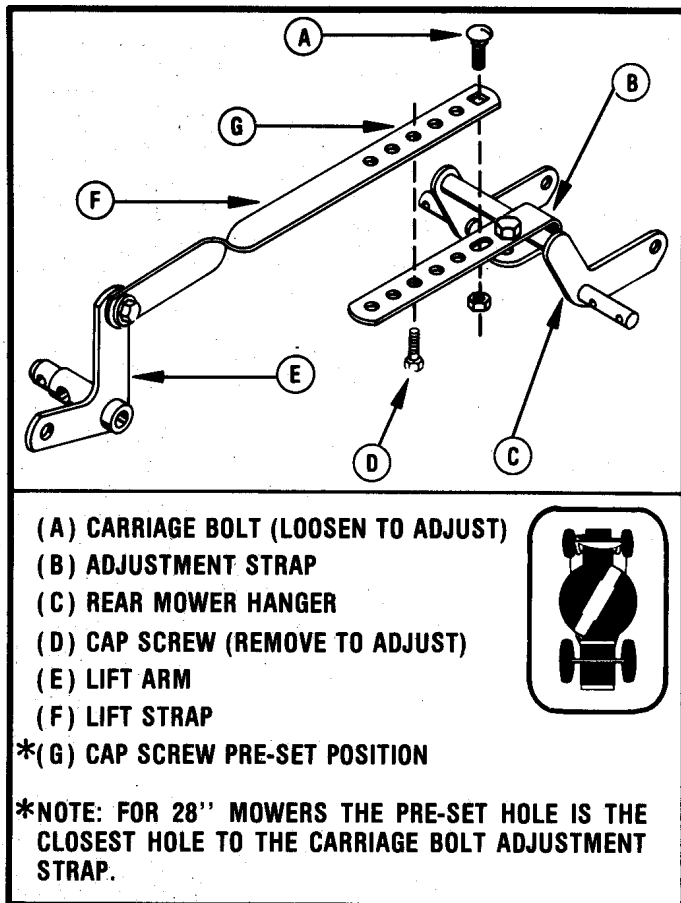

FIGURE 1-17

MOWER RUNNER ADJUSTMENT — 28" AND 32" ONLY

After adjusting the cutting height and blade pitch as described elsewhere in this section, the mower runners may be adjusted, as desired, to allow smooth, even cutting of grass at different cutting height settings. Adjustment must be even from side to side. Assemble outside spacers to runners and mower before center spacers. This will aid in alignment and ease of installation. Do not tighten hardware until outside spacers are installed.

- To obtain smoothest cutting in lowest cutting height settings, the runners may be adjusted as shown in Figure 1-18A.

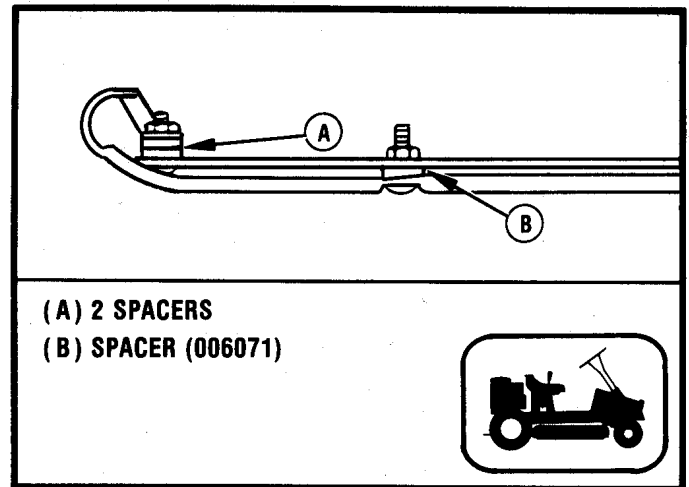

FIGURE 1-18A

- To pre-set the runners prior to a test cutting they may be adjusted as shown in Figure 1-18B.

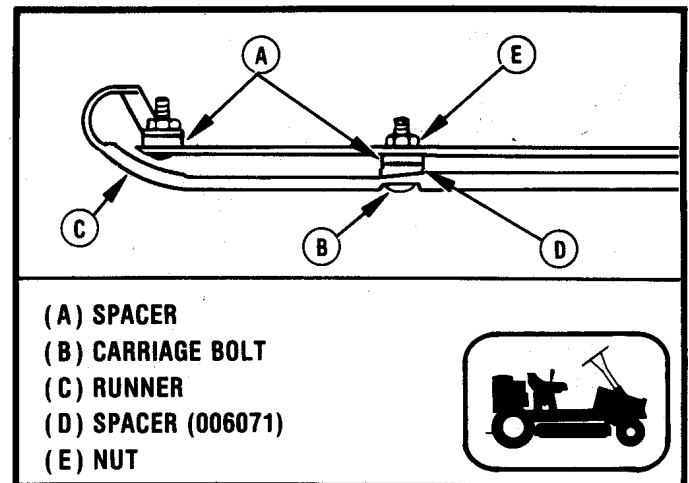

FIGURE 1-18B

- To obtain smoothest cutting in higher cutting height settings, the runners should be adjusted as shown in Figure 1-18C.

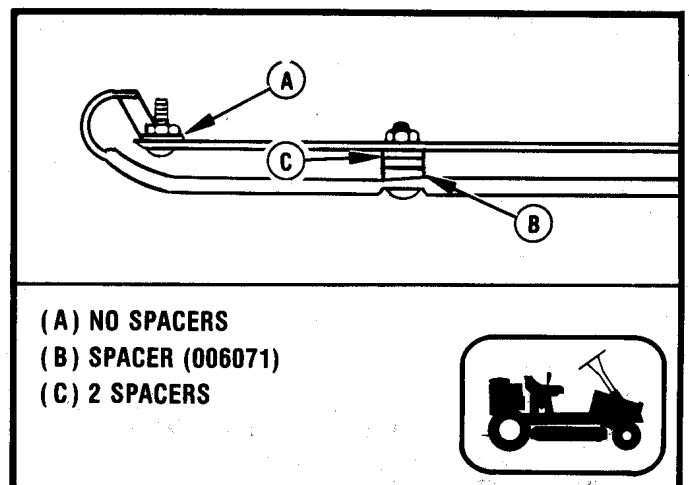

FIGURE 1-18C

ADJUSTMENTS/MAINTENANCE

MOWER LEVELING (SIDE-TO-SIDE) ADJUSTMENT — LATER MODELS — FIGURE 1-19

If mower cuts unevenly from side-to-side adjust the height of the right side of the mower pan by turning adjustment cap screw clockwise to raise the right side or counter-clockwise to lower the right side. See Figure 1-19. Before making this adjustment be sure tire pressure is correct and mower blade front-to-rear pitch is correct. After making side-to-side leveling adjustment be sure to check the front-to-rear pitch.

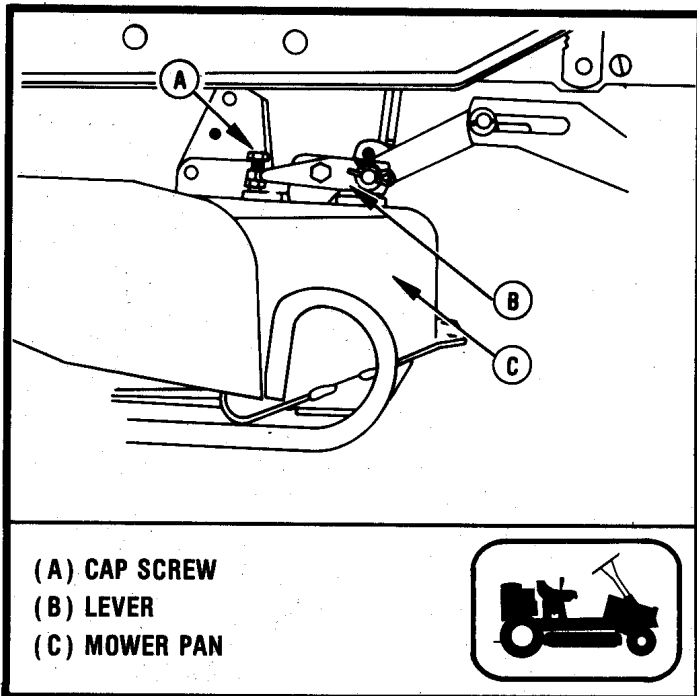
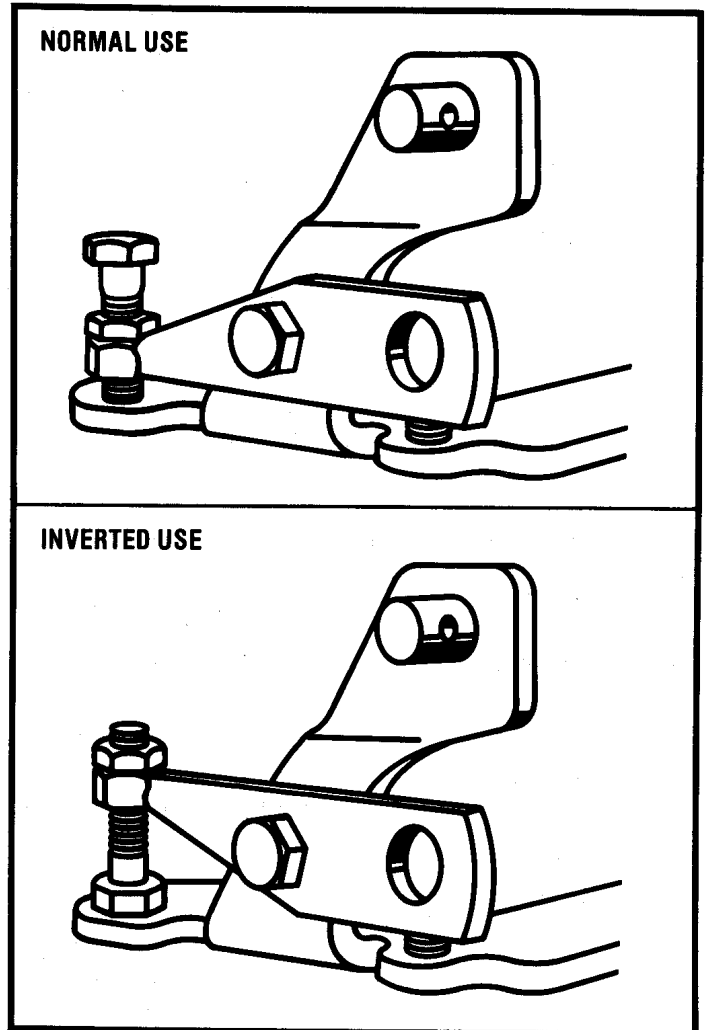

FIGURE 1-19

RIDING MOWER SERVICE ASSEMBLIES AND HIGH PERFORMANCE ACCESSORIES

Service assemblies, as included in this manual (527011, 17, 18), are available to improve cutting performance of Riding Mowers manufactured prior to 1980-81 model year. High Performance Accessories (as indicated on Page 3 of this manual) are available to improve grass collecting and grass bagging as well as mulching. References in this manual to these service assemblies and accessories are shown with the applicable model numbers. Refer to Pages 60-65 of this manual for detailed information.



LUBRICATION

ENGINE

Fill crankcase with oil as recommended below. Refer, also, to Engine Manufacturer's Instructions supplied with the product. Check oil level before each use and change oil regularly according to Engine Manufacturer's Instructions.

MODELS 927001, 2, 3, 5, 7, 8, 9, 10, 14, 17, 18, 20, 21, 24, 26	
SEASON	ENGINE OIL RECOMMENDATIONS
SUMMER: ABOVE 32° F (0° C)	SAE 30W or Substitutes: SAE 10W30, 10W40
WINTER: BELOW 32° F (0° C)	SAE 5W30 or Substitute: SAE 10W
Crankcase Capacity is 2 Pints.	
MODELS 927004, 6, 11, 12, 13, 15, 16, 23, 25, 27	
SUMMER: ABOVE 32°F (0°C)	SAE 30W or Substitutes: SAE 10W30, 10W40
WINTER: BELOW 32°F (0°C)	SAE 10W30, 10W40
BELOW 0°F (-17.8°C)	SAE 5W20, 5W30 or Substitutes: 5W20, 5W30, 5W40 Synthetic Oil
Crankcase Capacity is 2-1/4 Pints.	

FUEL TANK

Fill fuel tank with fresh, clean, lead free or regular gasoline. (Use only regular gasoline in Models 927004, 6, 11, 12, 13, 15, 16, 23, 25, 27)

NOTE: FOR DETAILED INFORMATION ON ENGINE REFER TO ENGINE MANUFACTURER'S INSTRUCTIONS PACKED WITH THE UNIT.

RIDING MOWER — FIGURE 2-1

Every 10 hours of operation (or sooner if required), oil idler pivot, steering gear, bellcrank on shift linkage and other pivot points. Dry lube sliding shaft.

WHEELS AND AXLES — FIGURE 2-1

Grease front wheel spindles and front axle pivot every 25 hours of operation, or sooner if required. The use of Ariens Multi-Purpose Grease, Part No. 000150, is recommended. Grease zerk fitting on left rear axle.

GEAR CASE — FIGURE 2-1

The gear case is factory lubricated and sealed for dirt-free operation.

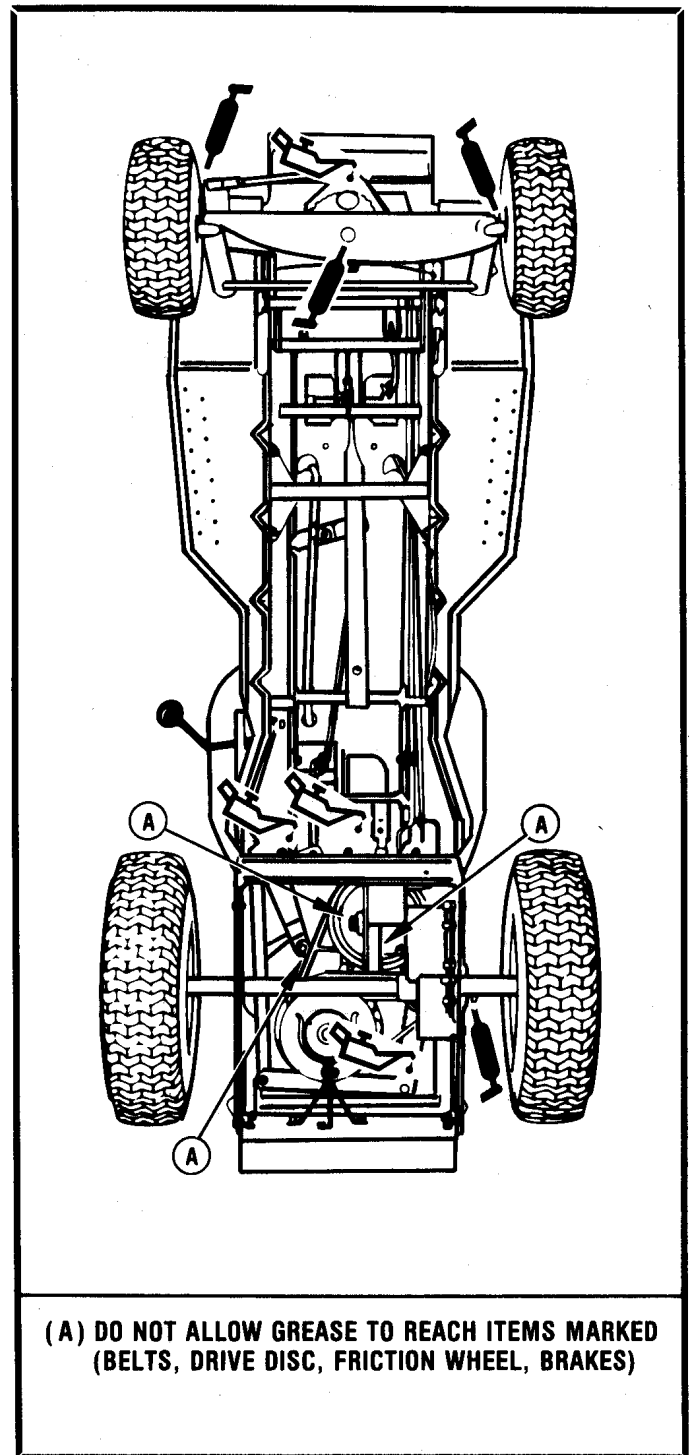

FIGURE 2-1

CARRIER ASSEMBLY (627028) — DIE CAST

NOTE: SEE PARTS MANUAL FOR COMPLETE ASSEMBLY.

REMOVAL OF THE CARRIER ASSEMBLY (ALL 927000 SERIES RIDING MOWERS — SEE DIAGRAM A)

1. Shift to "NEUTRAL".
2. Remove the cotter pin from the shift link.
3. Remove the shift link from the bellcrank.
4. Remove the cotter pin from one side of the transfer shaft.
5. Remove the extension spring from the clutch shaft.
6. Slide out the transfer shaft.
7. Unhook the "U" shaped part of the carrier assembly from the clutch shaft and remove the transfer frame.

DISASSEMBLY OF THE CARRIER ASSEMBLY (627028) — FIGURE 5-1

1. Remove the locknut (C) from top of the spindle bolt (K).
2. Remove the thrust washer (D).
3. Slide the drive disc assembly out of the bearing housing (E).
4. The ball bearing (F), sleeve bushing (G) and ball bearing (M) can be removed from the inside out.
5. The bearing housing is held in place with two flange whizlock screws (N); also, two flange whizlock screws hold the front of the carrier yoke (O) in place. With these four flange whizlock screws removed, the housing and yoke can be removed from the drive disc carrier (B).
6. Remove the shim washer (H) from the spindle bolt (K).
7. Remove the four flange whizlock screws (I) that secure the disc adapter (J) to the disc (L). As you lift off the adapter, the spindle bolt will fall free.

ASSEMBLY OF THE CARRIER (627028) — FIGURE 5-1

1. When assembling, use the proper thickness shim washer (H) between the disc adapter (J) and bearing (M).
2. Torque the locknut (C) that secures the assembly together to 250-275 in.-lbs.

NOTE: CARRIER ASSEMBLY (627028) DESIGN USED ON LATER MODELS.

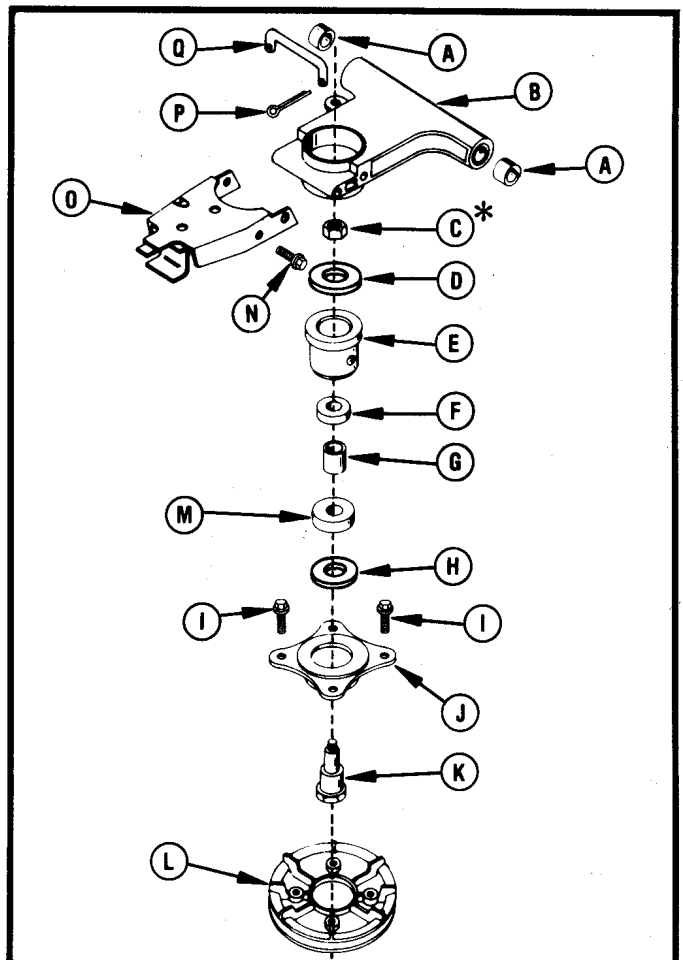

- (A) BUSHING—ASSEMBLY 527009
- (B) DRIVE DISC CARRIER—ASSEMBLY 527009
- (C) LOCKNUT
- (D) THRUST WASHER
- (E) BEARING HOUSING—ASSEMBLY 527009
- (F) BALL BEARING
- (G) SLEEVE BUSHING
- (H) SHIM WASHER
- (I) FLANGE WHIZLOCK SCREW, 5/16-18 x 3/4"
- (J) DISC ADAPTER
- (K) SPINDLE BOLT
- (L) DISC
- (M) BALL BEARING
- (N) FLANGE WHIZLOCK SCREW—ASSEMBLY 527009,
5/16-18 x 3/4"
- (O) CARRIER YOKE
- (P) COTTER PIN
- (Q) SHIFT LINK

*NOTE: TORQUE TO 250-275 IN.-LBS. (21 FT.-LBS.)

FIGURE 5-1

REPAIR

TRANSFER FRAME ASSEMBLY (627000) — STAMPED

NOTE: SEE PARTS MANUAL FOR COMPLETE ASSEMBLY

DISASSEMBLY OF THE TRANSFER FRAME USED ON MODELS 927001 AND 927002 — FIGURE 5-2

1. Place the spindle transfer frame on a bench.
2. Hold frame down with one hand and remove the hex nut (T) that secures the assembly together.

NOTE: TORQUE REQUIRED WHEN REPLACING THE HEX NUT SHOULD BE 45 FT.-LBS.

3. Next remove the lockwasher (S) and slide the transfer frame off the shaft (I).
4. There are two sleeve bushings (B) located at the rear of the transfer frame which can be removed by removing the four flange whizlock screws (E) that hold the bushing cover (A) in place.
5. Next, remove the spacer (D) from the shaft (I).
6. There are four flange whizlock screws (N) that secure the disc (M) to the drive disc hub (G).
7. There is a washer (K) in the cavity of the drive disc. Under it you may find one or more bearing shims (L).
8. Press the shaft (I) out of the drive disc hub (G).
9. The radial bearing (J) can be pressed off the shaft.
10. Remaining in the drive disc hub is a ball bearing (H) which can be pressed out.

ASSEMBLY OF THE TRANSFER FRAME USED ON MODELS 927001 AND 927002

Assembly of the 927001 and 927002 transfer frame is the reverse of the disassembly.

CAUTION: ADD PROPER AMOUNT OF BEARING SHIMS (L). TORQUE THE HEX NUT (T) AT THE TOP OF THE TRANSFER FRAME TO 45 FT.-LBS.

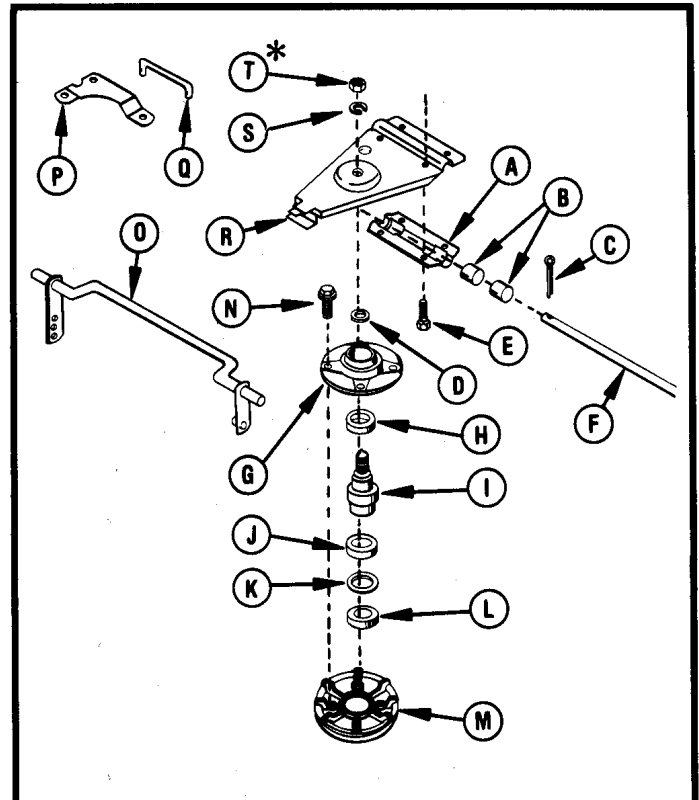

- (A) BUSHING COVER
- (B) SLEEVE BUSHING
- (C) COTTER PIN
- (D) SPACER
- (E) FLANGE WHIZLOCK SCREW
- (F) TRANSFER SHAFT
- (G) DRIVE DISC HUB
- (H) BALL BEARING
- (I) SHAFT
- (J) RADIAL BEARING
- (K) WASHER
- (L) BEARING SHIM
- (M) DISC
- (N) FLANGE WHIZLOCK SCREW
- (O) CLUTCH SHAFT
- (P) BELLCRANK
- (Q) SHIFT LINK
- (R) TRANSFER FRAME
- (S) LOCKWASHER
- (T) HEX NUT

*NOTE: TORQUE TO 45 FT.-LBS.

FIGURE 5-2

MOWER SPINDLE ASSEMBLY

NOTE: SEE PARTS MANUAL FOR COMPLETE ASSEMBLY.

REMOVAL OF THE MOWER SPINDLE SHAFT AND BEARINGS — FIGURE 5-3

1. Remove the jam nut (A) and lockwasher (B) and pull the mower sheave (C) from the top of the spindle (G).
2. Remove the jam nut (A) and lockwasher (B) and pull off the mower blade (K),(L) and blade tray (J),(M). Remove the retainer hub (I).
3. Remove the woodruff keys (F) from top and bottom of spindle. Remove the bearing slinger (H) from the bottom of the mower spindle.
4. The shaft now can be pressed out of the spindle housing (E) from either direction.
5. The bearing (D) that is left in the spindle housing after the shaft is removed can be pressed out from the inside.

REPLACEMENT OF THE BEARINGS AND SHAFT

1. Inspect the inside of the spindle housing (E) for burrs or damage and remove or replace as required.
2. Press one of the bearings (D) into the spindle housing.
3. Slide in the mower spindle (G) with the long side of the shaft facing the long side (top) of the spindle housing.
4. Press in the remaining bearing.
5. Rotate the mower spindle and check to see if there is any binding.
6. Replace the bearing slinger (H) on the bottom side of the mower spindle and replace the woodruff key (F).
7. Replace the woodruff key (F) in the upper end of the shaft.
8. Replace the retainer (I), blade tray (J),(M) and mower blade (K),(L) and torque the jam nut (A) to 50-55 ft.-lbs.
9. Replace the mower sheave (C) and torque the top jam nut (A) to 50-55 ft.-lbs.

NOTE: AFTER THE PROCEDURE IS COMPLETED ROTATE THE MOWER BLADE BY HAND TO CHECK IT FOR DRAG. IF THERE IS DRAG OR ROUGHNESS, DISASSEMBLE AND CHECK THE COMPONENTS. POSSIBLE CAUSES OF ROUGHNESS OR DRAG ARE:

1. Defective or worn bearings.
2. Spindle nuts over-torqued.
3. Bearing shoulders (defective spindle) too long on mower spindle.
4. Spindle housing defective.

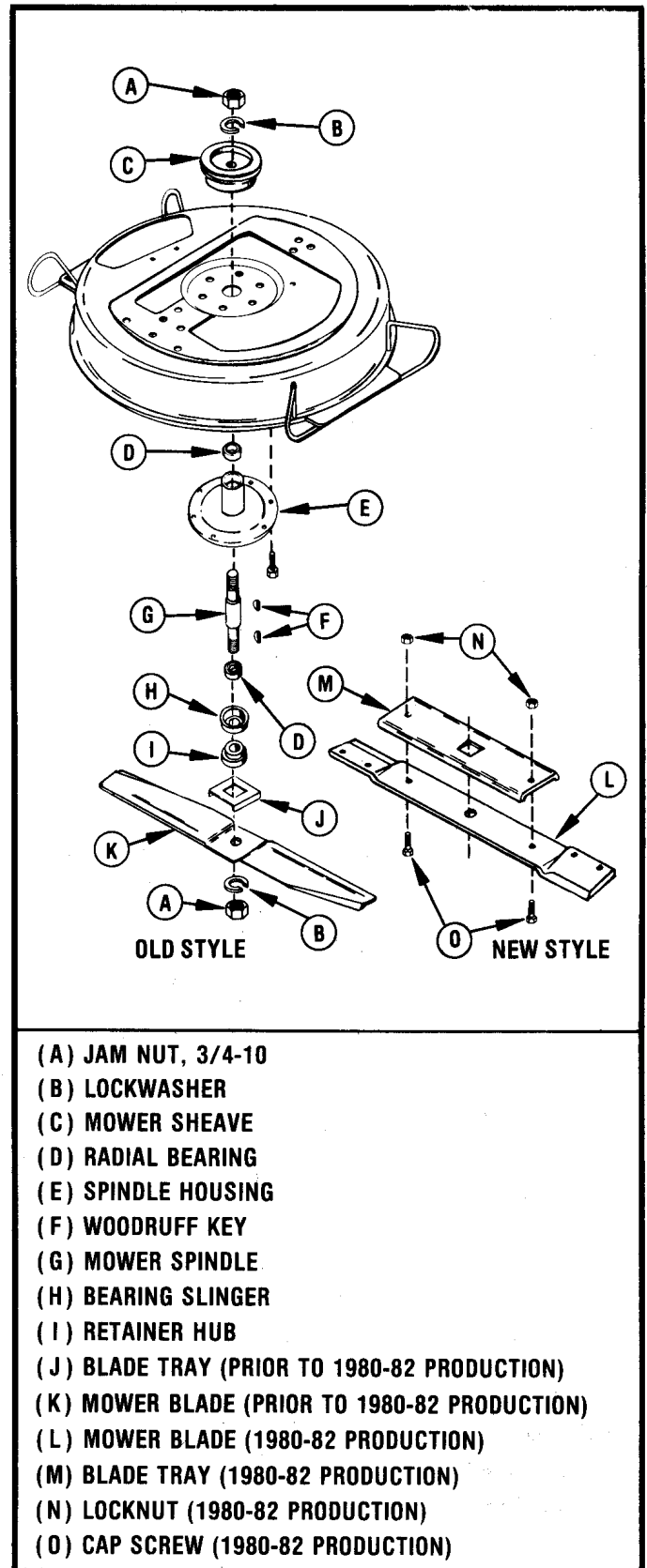

FIGURE 5-3

REPAIR

DRIVE ASSEMBLY

NOTE: SEE PARTS MANUAL FOR COMPLETE ASSEMBLY.

GEAR CASE REMOVAL — FIGURE 5-4

1. Remove the hub cap cotter pin (F), spindle cup (E) and hub cap (G) from the short (left side) axle (D).
2. Slide out the axle.
3. Drive the roll pin (B) out of the long (right side) axle (A), opposite the gear case.
4. Slide out the long axle.
5. Remove the washer (C) from the inside of the long axle bearing.
6. Remove the cotter pin (L) from the brake rod (N) and slide the rod out of the brake lever (M).
7. Remove the three flange whizlock screws (I) from the seal (H) and remove the seal.
8. Remove the three cap screws (J) that secure the gear case (K) to the frame.

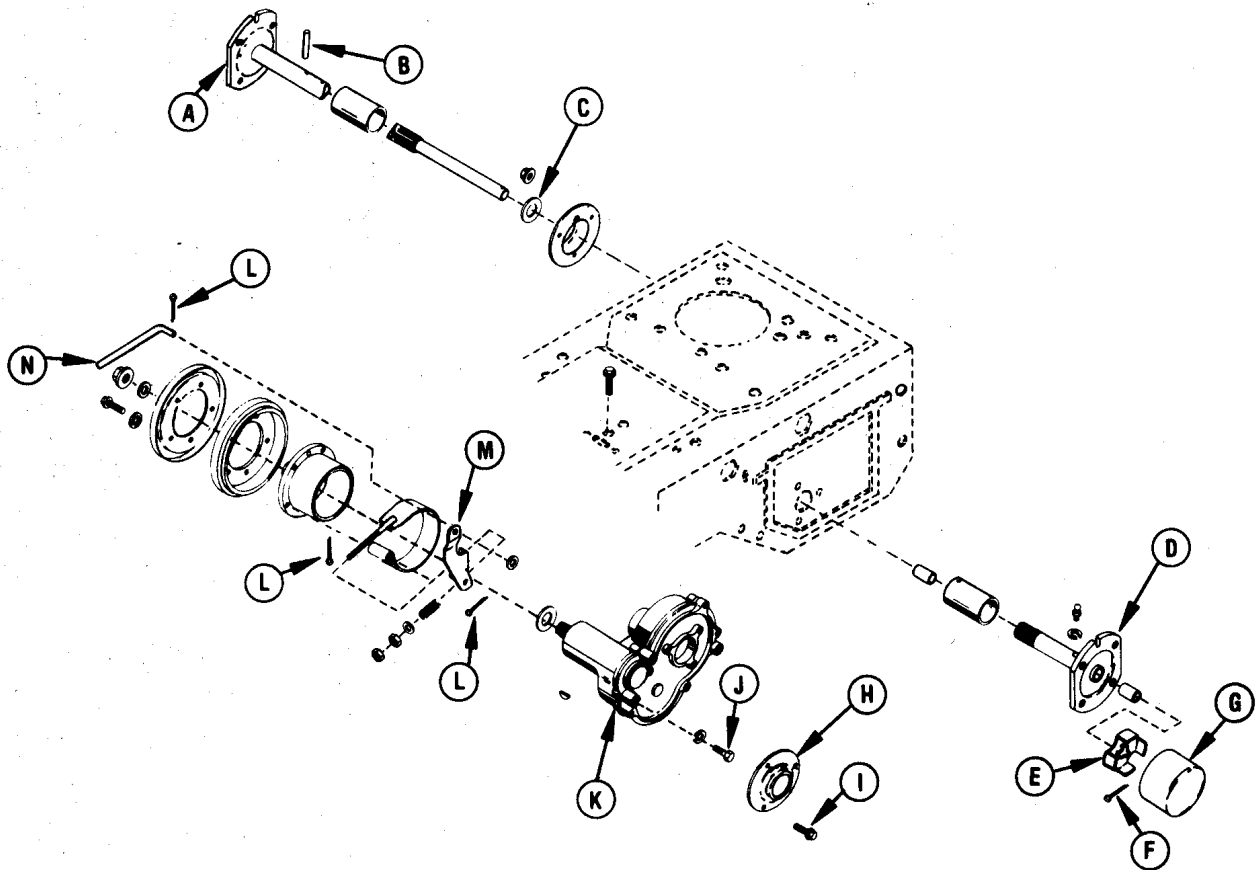

- | | |
|------------------------|---------------------------------|
| (A) R.H. AXLE | (H) SEAL |
| (B) ROLL PIN | (I) FLANGE WHIZLOCK SCREW |
| (C) WASHER | (J) CAP SCREW, 5/16-18 x 1 1/2" |
| (D) L.H. AXLE ASSEMBLY | (K) GEAR CASE ASSEMBLY |
| (E) SPINDLE CUP | (L) COTTER PIN |
| (F) COTTER PIN | (M) BRAKE LEVER |
| (G) HUB CAP | (N) BRAKE ROD |

FIGURE 5-4

DRIVE ASSEMBLY

GEAR CASE REPLACEMENT — FIGURE 5-4

1. Bolt gear case to frame.
2. Insert Axle Guide (Ariens Service Tool Part No. 000165) into gear case from inside of frame.
3. Slide in long axle (A) and secure with washer (C) and roll pin (B). Remove the Axle Guide.
4. Replace the seal (H) and secure with three flange whizlock screws (I).
5. Insert the short axle (D). Rotate to engage springs. Secure with spindle cup (E), cotter pin (L) and hub cap (G).
6. Replace the brake rod (N) in the brake lever (M). Secure with a cotter pin (L).

GEAR CASE ASSEMBLY

GEAR CASE DISASSEMBLY AND REPAIR — FIGURE 5-5.

1. Remove the locknut from the friction disc hub and slide off hub. (Torque to 70 ft.-lbs.)
2. Remove the woodruff key (T) from the pinion shaft (S).
3. Remove the flange whizlock screws (O) that secure the cover (P) to the case (E).
4. Insert two screwdrivers into the slots provided in the ends of the case and pry off the cover.
5. Inspect the breather (N) to see if it is clogged. If clogged, it can be removed by pushing it out from the inside. Replacement is pressed in from the outside.
6. Check the bearings for roughness. If replacement is necessary, the pinion shaft bearing (R) can be pressed out. First remove the aluminum flash from the outside of the cover above. The axle bearing (I) is removed by pressing it out from the inside.
7. The gasket (M) should be replaced each time the gear case is opened for repair.
8. The differential assembly (H) can now be removed for inspection. Place the differential in a vise. Insert both axle shafts. When turning the axle shaft from one side the outer shaft should turn freely in the opposite direction and vice versa.
9. Remove the washer (L) from the top of the pinion and gear cluster (Q).
10. The pinion shaft (S) and the pinion and gear cluster (Q) must be removed together. Inspect the pinion shaft bearing (R). If replacement is necessary it can be removed with a puller or be pressed off the shaft. Inspect the threaded end of the pinion shaft for wear and cross threads.
11. Inspect the pinion and gear cluster (Q) for damaged or missing needle bearings (K). If replacement is necessary they can be pulled or pressed out. When replacing, press in with the numbered side facing "OUT". Press in, flush with the face of the gear. Check cluster for damaged or broken teeth and replace if damaged.
12. Remove the flat washer (L) under the pinion and gear cluster.
13. To remove the idler shaft (J), place the end of the shaft in a vise. Tap the case with a mallet. Before replacing idler shaft, dress end of shaft if vise marks occur. If replacement of the roll pin (G) is necessary it can be driven out.
14. Inspect the seal (C). If replacement is necessary, it can be removed with a screwdriver. Replace by pressing in a new seal. Press in, flush with the face of the case.
15. Inspect the sleeve bushing (D). If replacement is necessary, remove by pressing from outside. To replace, press in sleeve bushing until it rests against the lip in case.
16. If replacement of the brake bracket (B) is necessary, remove the two hex nuts (A) that secure the bracket to the case. The ribbed-neck bolts (U) must be pressed out.

NOTE: WHEN REPLACING THE DIFFERENTIAL, THE INNER SPLINE (WITH THE SMALL I.D.) SHOULD FACE "DOWN" TOWARD THE INSIDE OF THE GEAR CASE.

REPAIR

GEAR CASE ASSEMBLY (527007)

NOTE: SEE PARTS MANUAL FOR COMPLETE ASSEMBLY

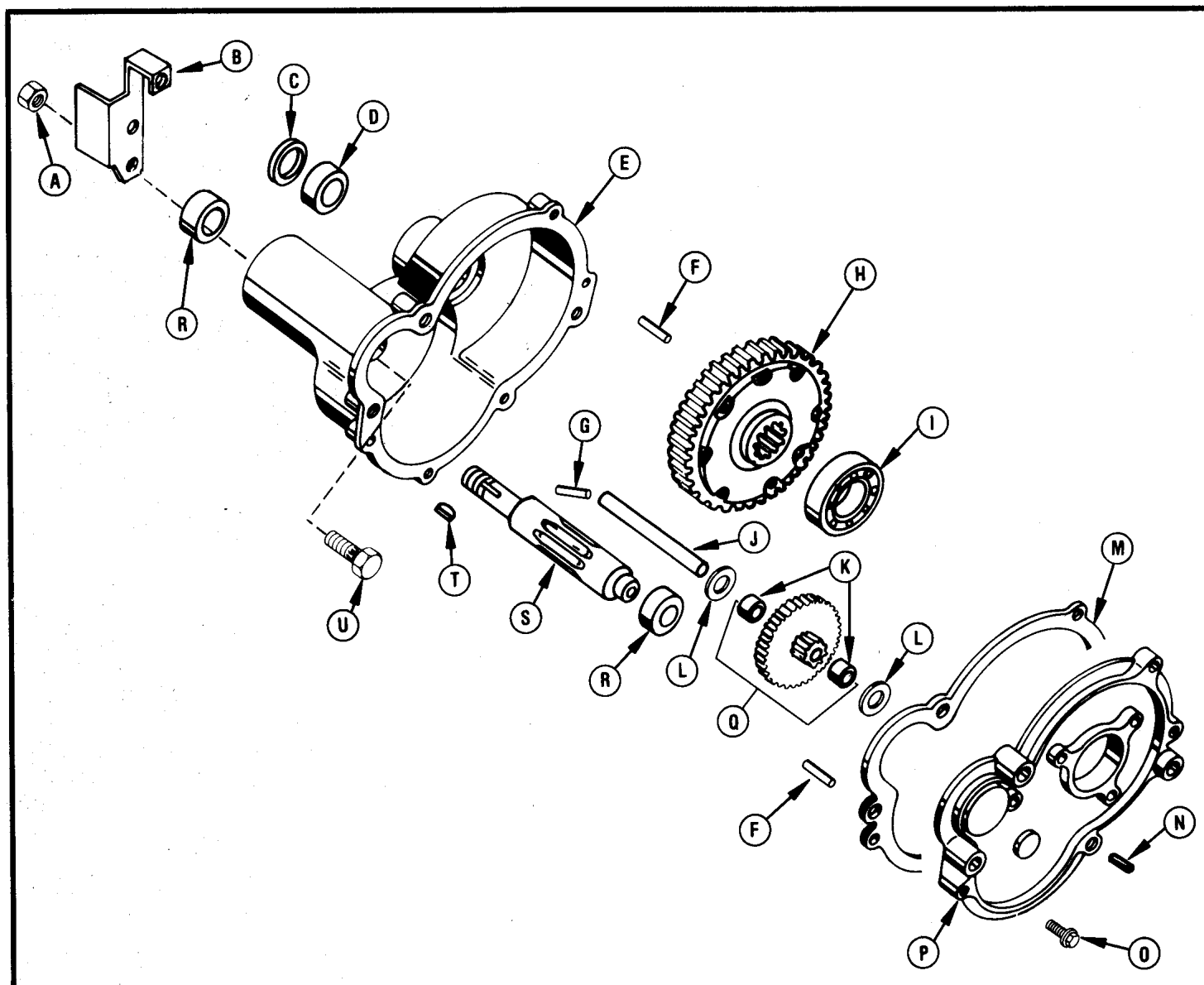

- | | |
|--|-----------------------------------|
| (A) HEX NUT | (L) WASHER |
| (B) BRAKE BRACKET | (M) GASKET |
| (C) SEAL | (N) BREATHER |
| (D) SLEEVE BUSHING | (O) FLANGE WHIZLOCK SCREW |
| (E) GEAR CASE WITH BUSHING, BEARING AND SEAL | (P) COVER ASSEMBLY |
| (F) GROOVE PIN | (Q) PINION AND GEAR WITH BEARINGS |
| (G) ROLL PIN | (R) BALL BEARING |
| (H) DIFFERENTIAL ASSEMBLY | (S) PINION SHAFT |
| (I) BALL BEARING | (T) WOODRUFF KEY, NO. 11 |
| (J) IDLER SHAFT | (U) RIBBED-NECK BOLT |
| (K) NEEDLE BEARING | |

FIGURE 5-5

STORAGE

Refer to Engine Manufacturer's Instructions supplied with the product.



CAUTION: NEVER STORE PRODUCT IN AN ENCLOSED AREA WHERE FUEL FUMES MAY REACH AN OPEN FLAME, SPARK, OR PILOT OF FURNACE, ETC. DRAIN FUEL OUTDOORS, AWAY FROM OPEN FLAME, AND USE ONLY AN APPROVED FUEL CONTAINER.

If product is to be un-used for thirty days or more prepare as follows:

1. Run engine until fuel tank is empty and engine stops due to lack of fuel.
2. Be sure all fuel is removed from fuel tank (as well as any contamination). The carburetor and fuel tank must be clean and dry to prevent gum deposits from forming and the engine from malfunctioning.
3. If gasahol has been used, complete the steps above, then put a small amount of regular gasoline into the fuel tank and repeat the steps.
4. Remove all oil, grease, dirt and debris from the engine.
5. Change the engine oil. See "LUBRICATION" section of this manual.
6. Check and, if necessary, clean the air filter and fuel filter.
7. For extra protection remove the spark plug and pour one tablespoon of oil into the cylinder. Turn engine over manually (two revolutions of crank shaft).
8. Regap the spark plug. See "SPECIFICATIONS" section of this manual. Replace spark plug if required.

BATTERY

Refer to "BATTERY SET-UP AND MAINTENANCE"

GENERAL

Store product in a cool, dry place to reduce tire deterioration. Blocking under the product frame will take the weight off the tires.

Store unit with Speed Control Lever in "NEUTRAL" position only.

Inspect product for visible signs of wear, breakage or damage. Order any parts required and make necessary repairs to avoid delays when beginning use again.

Clean the product thoroughly. Touch up all unpainted and exposed areas with paint to avoid rust.

NOTE: ARIENS RECOMMENDS USING A HIGH QUALITY PRIMER AS A BASE FOR THE TOUCH-UP PAINT. THE TOUCH-UP PAINT WILL NOT PROVIDE THE HIGH GLOSS FINISH OF ORIGINAL BAKED-ON PAINT. COLOR MAY VARY SLIGHTLY, ALSO.

BATTERY SET-UP AND MAINTENANCE



WARNING: STORAGE BATTERIES GIVE OFF HIGHLY FLAMMABLE HYDROGEN GAS. DO NOT ALLOW SPARKS OR FLAME NEAR BATTERY. DO NOT LAY TOOLS ACROSS BATTERY TERMINALS WHICH MAY CAUSE A SPARK RESULTING IN AN EXPLOSION.

CAUTION: ELECTROLYTE CONTAINS SULPHURIC ACID WHICH IS HARMFUL TO SKIN, EYES AND CLOTHING. HANDLE WITH EXTREME CARE. IF SPILLAGE OCCURS ON BODY OR CLOTHING, RINSE AT ONCE WITH WATER.

WARNING: REVERSED BATTERY CABLES, REVERSED CABLES FROM A BATTERY CHARGER, OR BOOSTER BATTERY CAN CAUSE DAMAGE TO THE PRODUCT. SPARKS AND POTENTIAL HAZARDS TO OPERATOR COULD RESULT. MAKE CERTAIN THE GROUND CABLE IS CONNECTED TO THE FRAME AND THE POSITIVE CABLE IS CONNECTED TO THE POSITIVE (+) TERMINAL.

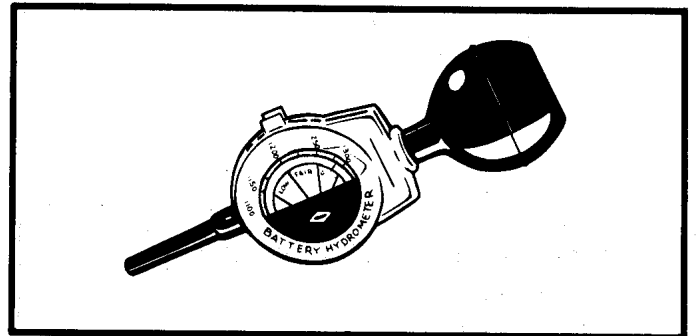

NOTE: THE HYDROMETER, PART NO. 000140, OFFERED THROUGH ARIENS IS RECOMMENDED FOR ALL SET-UP AND MAINTENANCE PROCEDURES OF ARIENS BATTERIES.

SET-UP

Battery is dry charged. Dealer or customer must add electrolyte (sulfuric acid and water).

1. Remove battery from unit.
2. Remove all the vent caps from the battery and set the caps to one side.

INSTALLATION

SERVICE BAR ASSEMBLY FOR SRM MODELS

NOTE: FOR ALL ARIENS 927000 SERIES SRM MODELS THE ADDITION OF A SERVICE BAR ASSEMBLY IS REQUIRED FOR INSTALLATION OF A GRASS BAGGER. THE FOLLOWING SERVICE BAR PARTS ARE AVAILABLE THROUGH YOUR ARIENS DEALER:

1. SERVICE BAR (027012)
2. SERVICE BAR BRACE (027227)—2
3. CAP SCREW (059045)—4
4. LOCKNUT (065042)—4

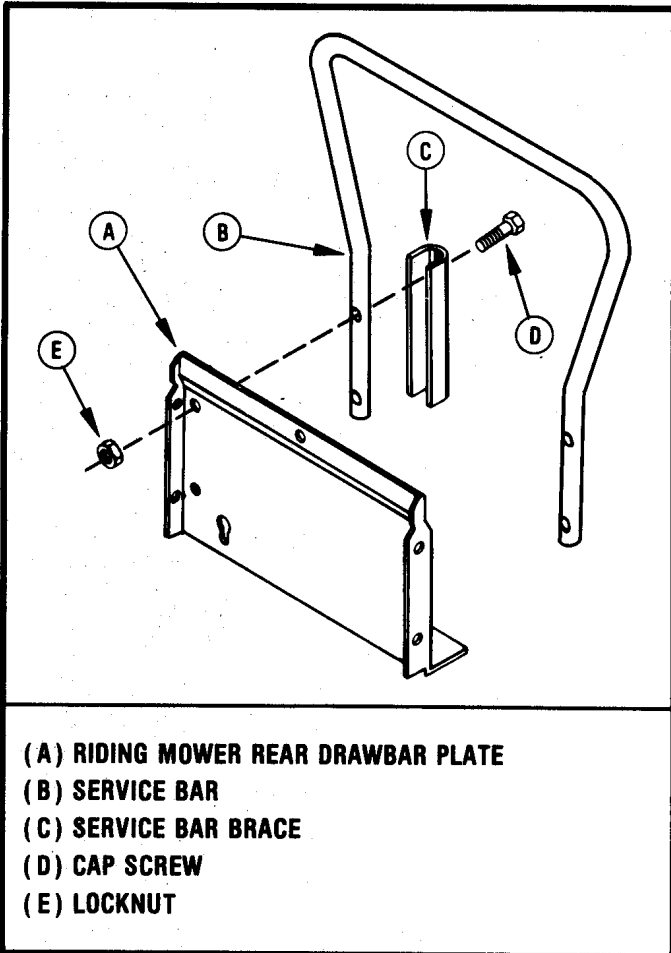

FIGURE 11-1

FLANGE ASSEMBLY — GENERAL

IMPORTANT: FOR 30" AND 32" MODEL RIDING MOWERS A HIGH PERFORMANCE FLANGE ASSEMBLY IS SUPPLIED WITH THE GRASS BAGGER. BEFORE INSTALLING GRASS BAGGER ON 30" OR 32" MODELS THE HIGH PERFORMANCE FLANGE ASSEMBLY MAY BE INSTALLED ACCORDING TO THE FOLLOWING INSTRUCTIONS. SEE "HIGH PERFORMANCE FLANGES" INFORMATION IN "OPERATION" SECTION OF THIS MANUAL FOR FLANGE USE.

NOTE: FOR ARIENS 30" SRM SERIES RIDING MOWER MODELS 927017, 20, 27, AS WELL AS 30" RM MODELS 927024—SERIAL NO. 005501 AND UP, AND 927025—SERIAL

NO. 004001 AND UP, A BLADE TRAY ASSEMBLY (SUPPLIED WITH 30" GRASS BAGGER) MUST BE INSTALLED ON THE MOWER BLADE PRIOR TO INSTALLATION OF FLANGE ASSEMBLY. THE BLADE SHOULD BE REMOVED, THEN CHECKED FOR WEAR AND REPLACED, IF REQUIRED. BEFORE INSTALLING BLADE TRAY, USE TWO 3/8-16 CAP SCREWS (D) AND TWO 3/8-16 LOCKNUTS (E) TO ASSEMBLE BLADE TRAY AND BLADE. REFER TO FIGURE 11-1. ASSEMBLE AS FOLLOWS:

Refer to your Owner's Manual to remove/replace the mower blade. *For SRM and later RM 30" models the mower blade and original blade retainer must be removed. Remove the jam nut and lockwasher to free the blade assembly from the spindle, bearing slinger and hub assembly. Position the new blade tray supplied with the Grass Bagger on the existing mower blade. (NOTE: MOWER BLADE SHOULD BE REPLACED IF WORN OR DAMAGED PRIOR TO INSTALLATION OF THE BLADE TRAY.) Secure the blade tray to the blade with two 3/8-16 cap screws and locknuts as shown. Be sure to tighten this hardware completely. Slide the blade and blade tray assembly onto the spindle as shown. Replace the lockwasher and jam nut and tighten to 50-55 ft.-lbs. with a torque wrench.

* NOTE: FOR SRM MODELS IT MAY BE EASIEST TO INSTALL THE SERVICE BAR ASSEMBLY PRIOR TO INSTALLING THE BLADE TRAY ASSEMBLY. THIS WILL ALLOW ACCESS TO THE MOWER UNDERSIDE BY TIPPING RIDING MOWER ONTO SERVICE BAR. SEE NOTE ABOUT SERVICE BAR ASSEMBLY ON THIS PAGE.

Flange assemblies are supplied for use on Ariens 30" and 32" Riding Mowers as follows:

MODEL NO.	SERIAL NO.
927010—30"	001001 and up
927011—30"	001001 and up
927017—30"	000101 and up
927020—30"	000101 and up
927024—30"	000101 and up*
927025—30"	000101 and up*
927027—30"	000101 and up

*927924 (up to Serial No. 005501) has flange assembly as standard equipment.

*927025 (up to Serial No. 003456) has flange assembly as standard equipment.

MODEL NO.	SERIAL NO.
927012—32"	000101 and up
927013—32"	000101 and up
927015—32"	000501 and up
927016—32"	000501 and up*
927023—32"	000101 and up**
927026—32"	000101 and up*

*Flange assembly is standard on these models.

**927023 (up to Serial No. 002801) has flange assembly as standard equipment.

GRASS BAGGER MODELS 827020 AND 827021

INSTALLATION

FLANGE ASSEMBLY INSTALLATION PARTS—EXPLODED VIEW

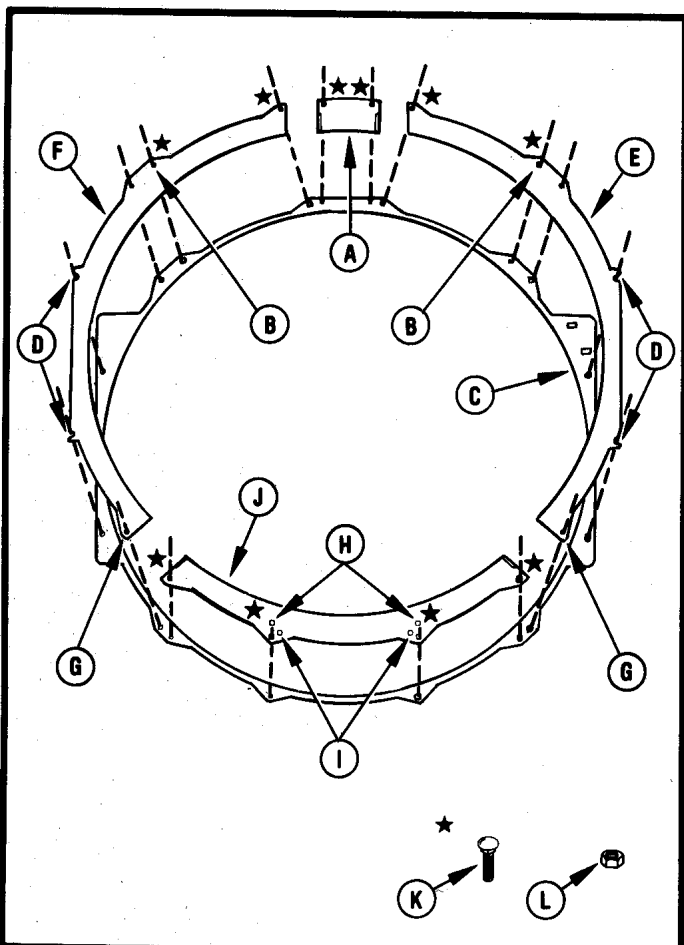

- (A) FRONT FLANGE
- (B) USE THIS HOLE
- (C) RIM OF MOWER PAN
- (D) LOOSEN AND MOUNT 32" FLANGE WITH RUNNER HARDWARE
- (E) SIDE FLANGE, LH-30"
- (F) SIDE FLANGE, RH-30"
- (G) FOR 30" USE CARRIAGE BOLT, 5/16-18 x 5/8", AND LOCKNUT, 5/16-18
- (H) USE THESE HOLES FOR 32"
- (I) USE THESE HOLES FOR 30"
- (J) REAR FLANGE
- (K) CARRIAGE BOLT, 1/4-20 x 5/8"
- (L) LOCKNUT, 1/4-20

★ DENOTES LOCATION OF THIS HARDWARE

FIGURE 11-2



CAUTION: BE ESPECIALLY CAREFUL WHEN INSTALLING THE FLANGE ASSEMBLY ON THE MOWER. FAILURE TO FOLLOW THE INSTALLATION PROCEDURE AS DESCRIBED COULD RESULT IN DAMAGE TO THE MOWER OR PROPERTY AND/OR PERSONAL INJURY.

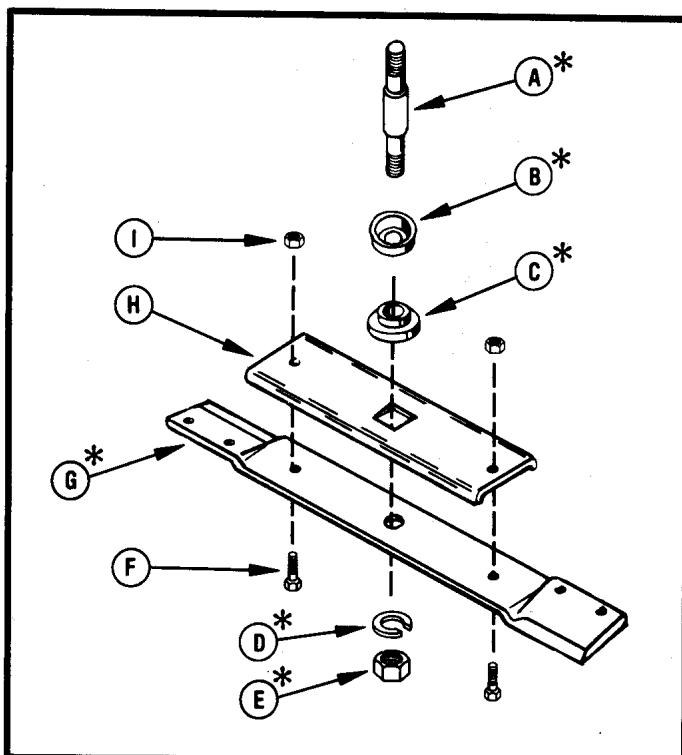

- (A) SPINDLE
- (B) BEARING SLINGER
- (C) RETAINER HUB
- (D) LOCKWASHER
- (E) JAM NUT
- (F) CAP SCREW
- (G) 30" BLADE
- (H) BLADE TRAY
- (I) LOCKNUT

NOTE: ITEMS F, H AND I ARE INCLUDED IN THE 30" GRASS BAGGER MODEL FOR INSTALLATION ON SRM AND LATER MODEL RM RIDING MOWERS. SEE NOTE ABOUT THE BLADE TRAY ASSEMBLY, PAGE 3, PRIOR TO INSTALLING THE FLANGE ASSEMBLY.

* THE ORIGINAL RIDING MOWER COMPONENTS MAY BE RE-USED FOR INSTALLATION OF THE BLADE AND TRAY.

FIGURE 11-3

INSTALLATION

FLANGE ASSEMBLY INSTALLATION

The flange assembly supplied is designed to improve the grass pick-up of mowers when using Grass Bagger.

The procedure for installation is detailed following. In general the Riding Mower is tipped onto service bar (see "CAUTION" below) or mower pan is removed. The flange assembly is positioned around the mower pan; then the blade clearance from the flange is checked and corrected if required. The mower pan may now be re-installed. The mower is then checked for grass pick-up and the blade vanes supplied are attached, if required.



CAUTION: WHEN INSTALLING MOWER PARTS AND MAKING ANY ADJUSTMENT OR REPAIRS REMOVE SPARK PLUG WIRE. TO AVOID SPILLING BATTERY ACID OR FUEL WHEN INSTALLING MOWER PARTS AND MAKING REPAIRS OR ADJUSTMENTS REQUIRING ACCESS TO THE BOTTOM OF THE UNIT, BE SURE TO REMOVE THE BATTERY AND DRAIN THE FUEL TANK BEFORE TIPPING RIDING MOWER ONTO SERVICE BAR. DRAIN FUEL TANK BY REMOVING FUEL LINE AT CARBURETOR OR FUEL TANK, WHICHEVER IS EASIER. AFTER FUEL TANK IS DRAINED, RUN ENGINE TO REMOVE REMAINING FUEL IN CARBURETOR. REMOVE AIR CLEANER ELEMENT. FAILURE TO FOLLOW THESE PRECAUTIONS WILL RESULT IN THE AIR CLEANER ELEMENT BECOMING SOAKED WITH FUEL, PICKING UP DIRT AND CHOKING THE ENGINE. THE FUEL DRAWN INTO THE CYLINDER AND WASHING THE CYLINDER WALLS WILL ALSO SHORTEN ENGINE LIFE.

Install the flange assembly as follows. See Figure 11-2.

1. Install side flanges to mower pan using carriage bolts and locknuts, 1/4-20, as shown in Figure 11-4. At points indicated, loosen, and mount with mower runner hardware as indicated in Figure 11-2. For 30" pan see Figure 11-8.

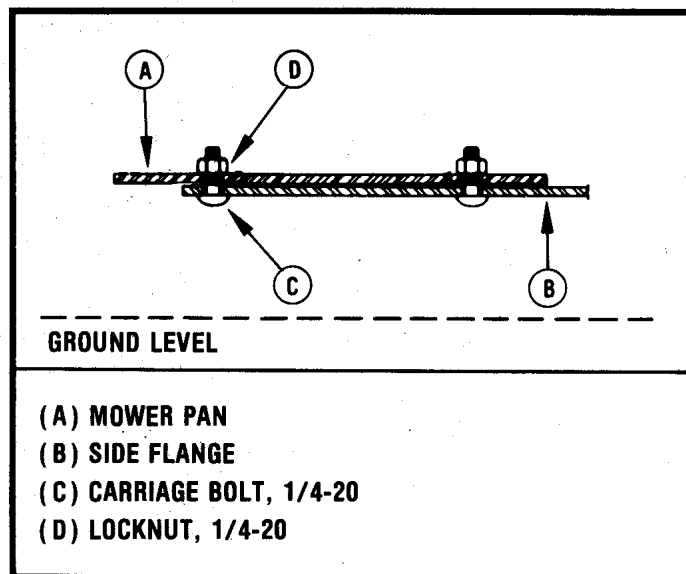

FIGURE 11-4

NOTE: THE CARRIAGE BOLTS SHOULD ASSEMBLE AGAINST THE BOTTOM OF THE FLANGES IN ONLY THE HOLES SHOWN IN FIGURE 11-2.

2. Assemble the front flange to mower pan between the two side flanges. See Figure 11-5.

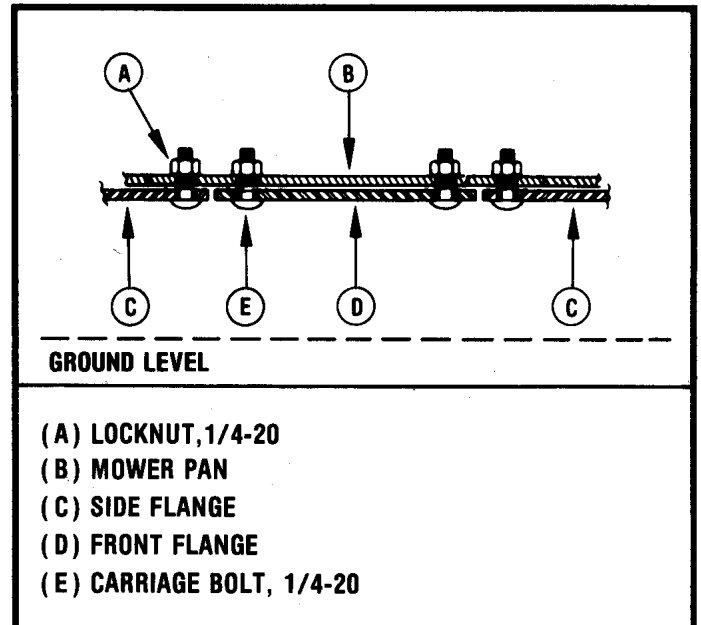

FIGURE 11-5

3. Assemble the rear flange to the mower pan using carriage bolts and locknuts, 1/4-20. See Figure 11-6 and 11-7.

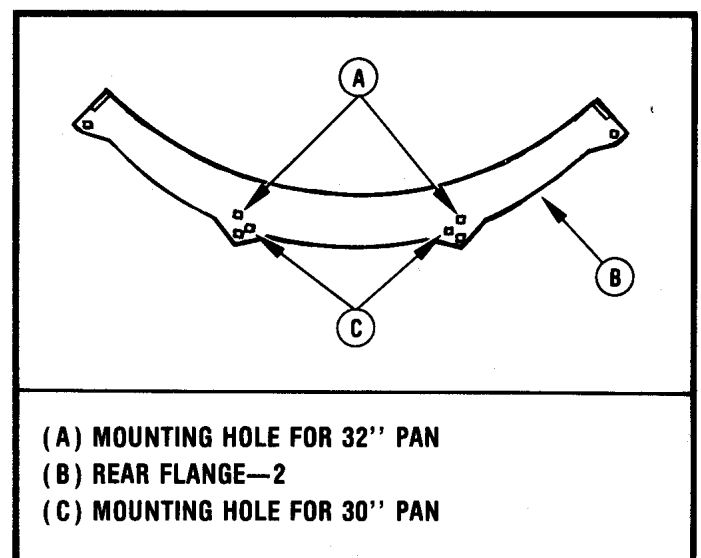

FIGURE 11-6

GRASS BAGGER MODELS 827020 AND 827021

INSTALLATION

FLANGE ASSEMBLY INSTALLATION (CONTINUED)

- Carefully position the flange assembly on the mower pan so that the side flanges are positioned between the runners (if so equipped) and the mower pan bottom. The flange on the mower pan and the edges of the side flanges should fit flush at the front. See Figure 11-8.

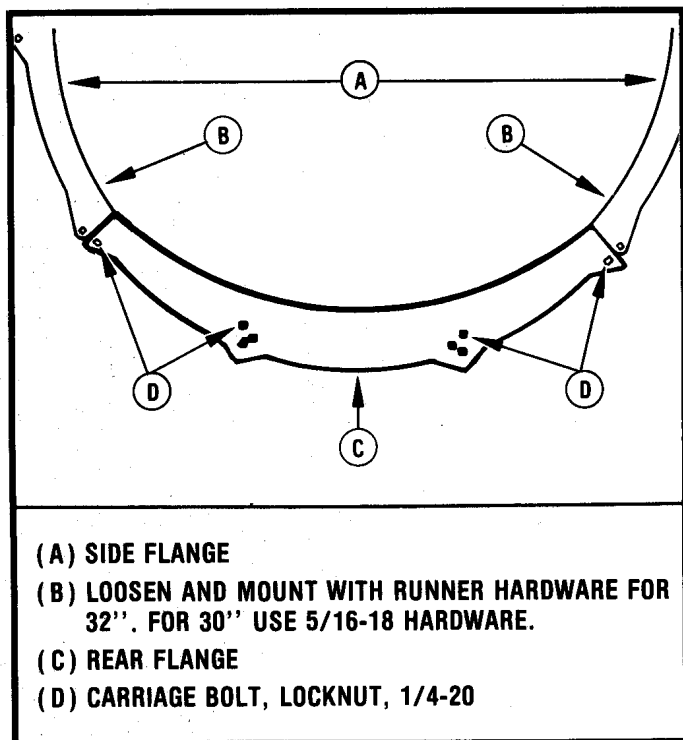

FIGURE 11-7

- Read the "CAUTION" instructions at the beginning of this section to remove spark plug wire.

Using a glove, carefully rotate the mower blade by hand and check to be sure there is 1/4"-3/8" minimum clearance between the blade cutting edges and the flanges all the way around the pan and there are no major variations in the surface from one flange to another. If there are, loosen hardware and retighten after repositioning or bend the flanges slightly if necessary.

NOTE: WHEN USING VANES ON BLADE, CHECK TO BE SURE THERE IS AT LEAST 1/4" CLEARANCE BETWEEN TOP OF VANE AND TOP OF DECK ON 32" MODELS AT REAR.



CAUTION: BE SURE TO CHECK THE SECURITY OF THE FLANGES AND THE HARDWARE TIGHTNESS PRIOR TO OPERATING MOWER.

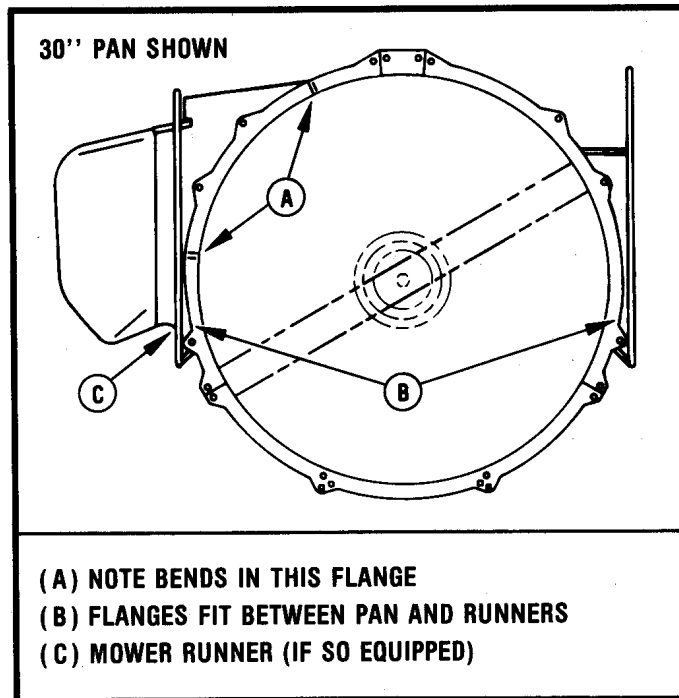

FIGURE 11-8

INSTALLATION OF GRASS BAGGER MOUNTING BRACKET — FIGURE 11-9

Install mounting bracket from parts bag on drawbar plate of Riding Mower, as shown in Figure 11-9, with 1/2-13 x 1" cap screw, lockwasher and nut from parts bag.

INSTALLATION OF BAGGER FRAME AND COVER ASSEMBLY — FIGURE 11-9

- Refer to Figure 11-9. Install bagger tube frame assembly to bagger cover assembly with machine screws and locknuts supplied in parts bag. Attach corners of bagger tube frame assembly to bagger corner brackets with four tapping screws from parts bag.
- Install tube frame and cover assembly to Riding Mower service bar. Position the assembly so the two cap screws extending from the bottom of the mounting bracket go in the outer holes in the service bar and the stud that extends from the bottom of the tube goes in the right hand hole in the mounting bracket on the drawbar. Fasten the assembly to the service bar with two wing nuts, and use a hair-pin to retain the stud to the mounting bracket. See Figure 11-9.

INSTALLATION

GRASS BAGGER INSTALLATION PARTS — EXPLODED VIEW

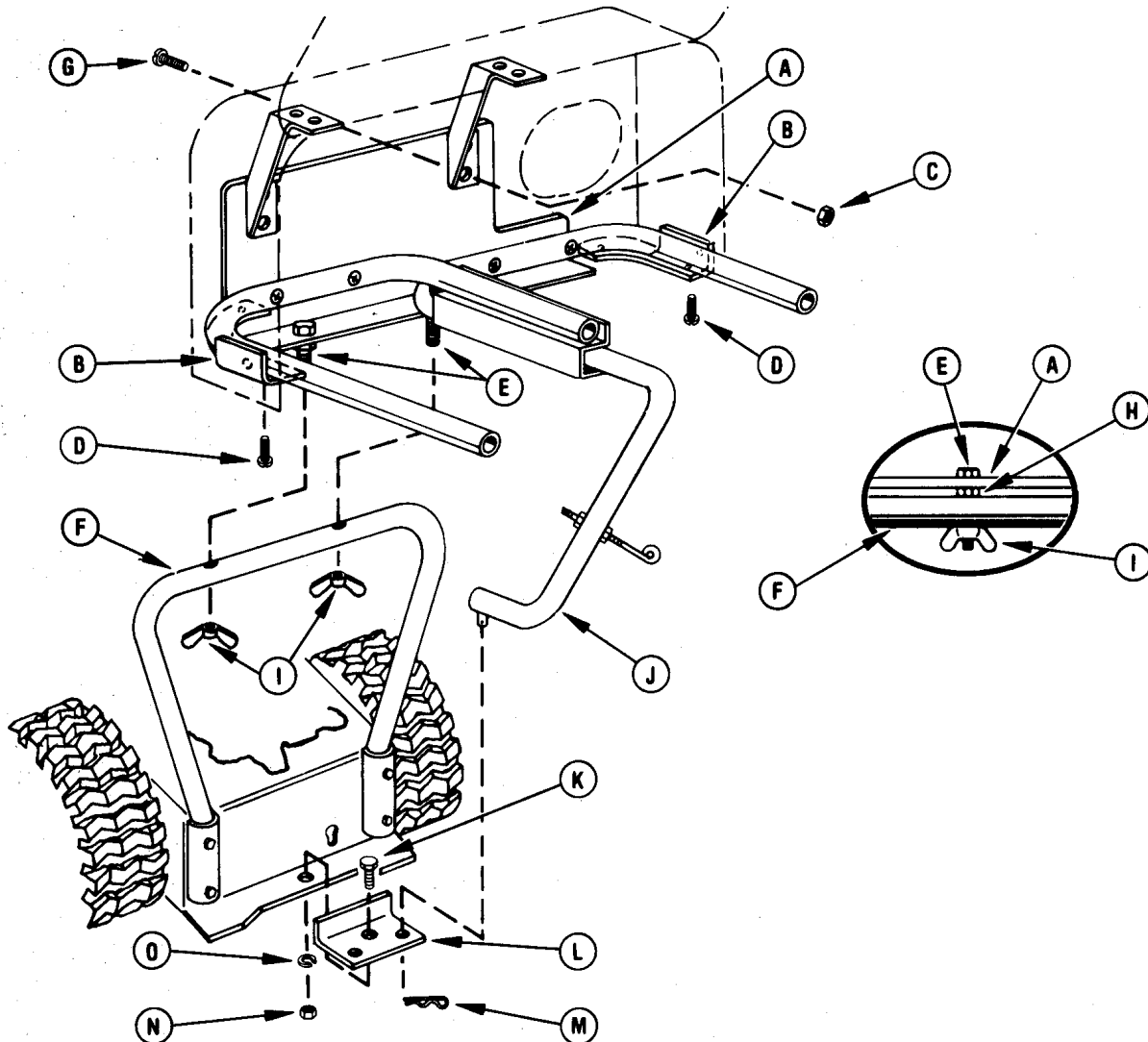

(A) BAGGER MOUNTING BRACKET—INSIDE OF BAGGER COVER ASSEMBLY

(B) CORNER BRACKET

(C) LOCKNUT

(D) TAPPING SCREW

(E) CAP SCREW (WITH LOCKNUT ON BOTTOM SIDE)

(F) SERVICE BAR

(G) MACHINE SCREW

(H) LOCKNUT

(I) WING NUT

(J) BAGGER TUBE ASSEMBLY

(K) CAP SCREW, 1/2-13 x 1"

(L) RIDING MOWER MOUNTING BRACKET

(M) HAIRPIN

(N) NUT, 1/2-13

(O) LOCKWASHER

NOTE: FOR SRM MODEL RIDING MOWERS NOT EQUIPPED WITH A SERVICE BAR REFER TO THE NOTE ABOUT THE SERVICE BAR ASSEMBLY ON PAGE 3 OF THIS MANUAL.

FIGURE 11-9

INSTALLATION

BOOT ASSEMBLY — 32''

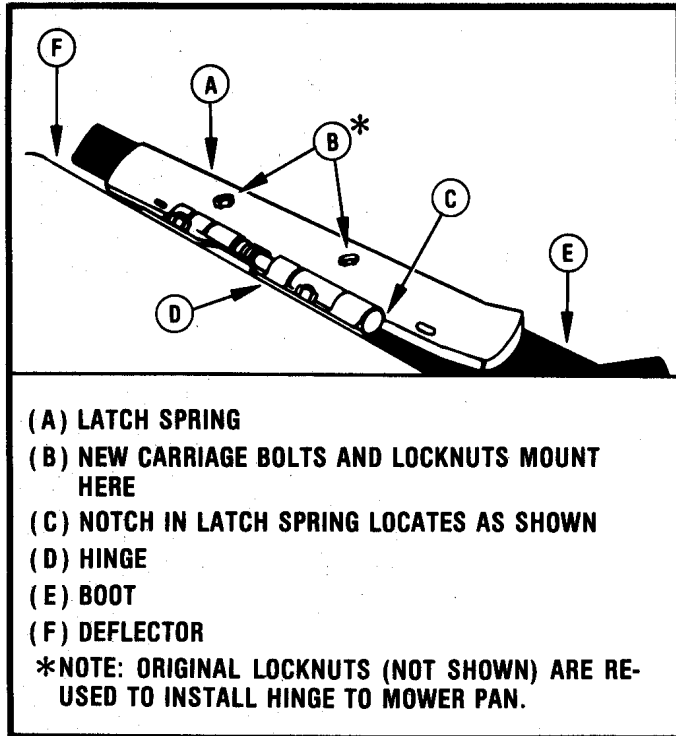

FIGURE 11-10

Install latch spring from parts bag as follows:

1. Remove one of the existing carriage bolts and locknuts securing hinge of chute deflector to mower pan. See Figure 11-10. Discard the carriage bolt and retain the locknut. Install one of the new longer carriage bolts from parts bag in place of the original carriage bolt. Secure the hinge with the original locknut. Repeat this procedure for the other carriage bolt and locknut so that hinge is secured in both points with new carriage bolts.
2. Install latch spring over the re-installed locknuts securing the hinge and secure it in position with new locknuts from parts bag as shown in Figure 11-10.

FINAL INSTALLATION — 32'' BOOT AND TUBE

Install the 32'' boot as shown in Figures 11-10 and 11-11 by positioning the bottom of the boot on the mower pan studs and the top of the boot underneath deflector and latch spring so that the holes in the boot engage the latch spring pins. Secure bottom of boot with two wing nuts supplied in parts bag. Assemble and install tube as shown in Figure 11-11.

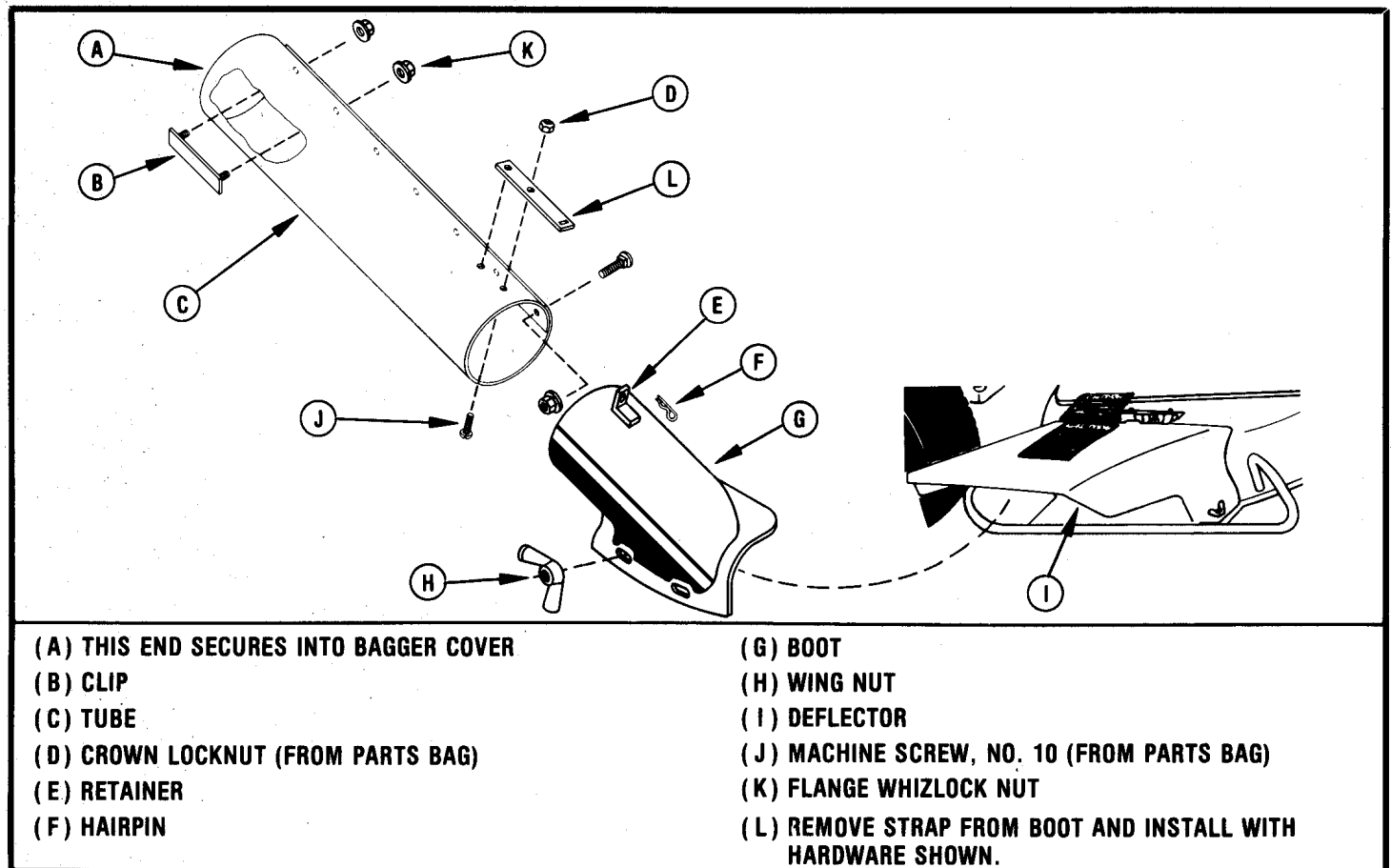
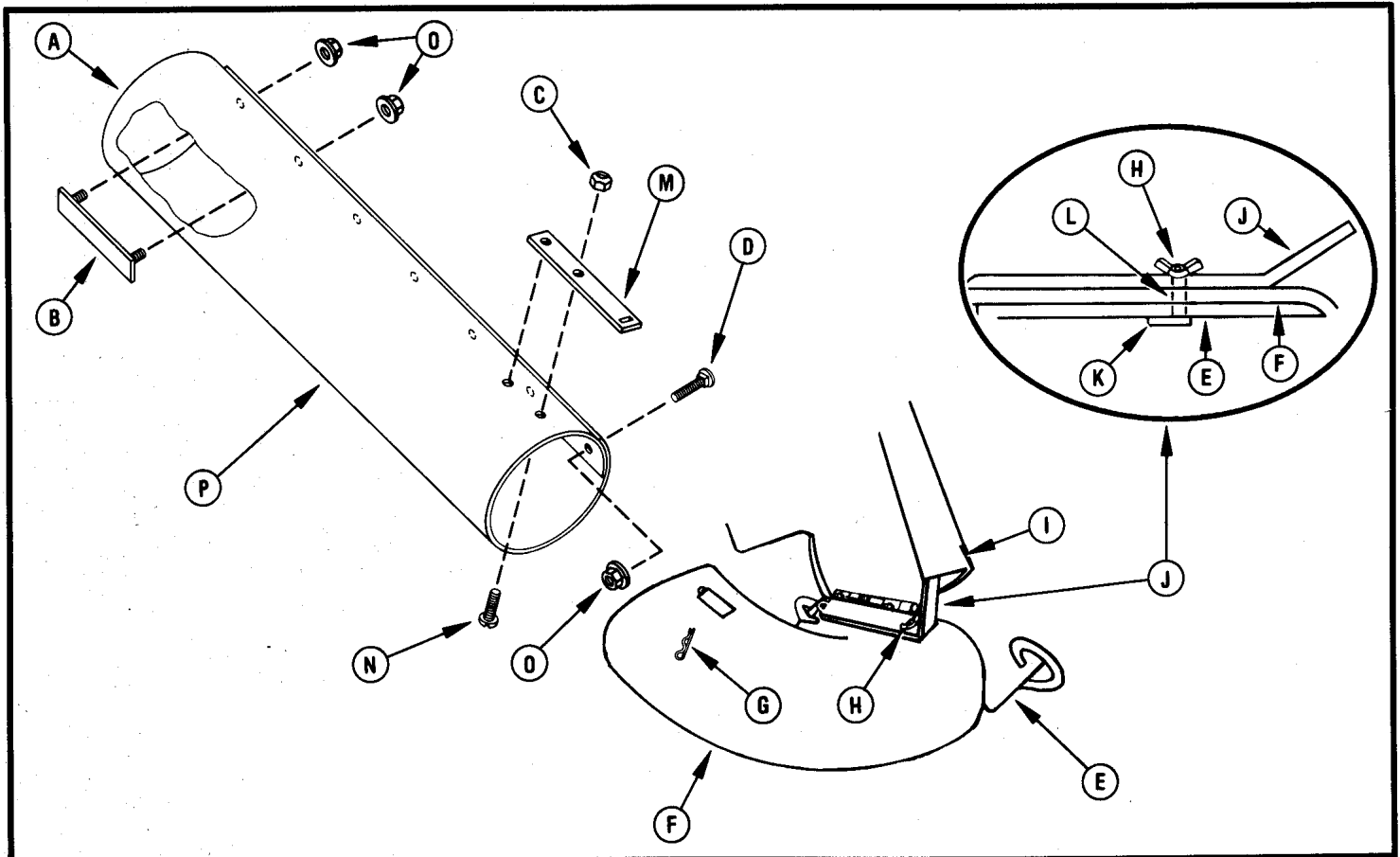

FIGURE 11-11

INSTALLATION

FINAL INSTALLATION — 26' AND 30' BOOT AND TUBE



(A) THIS END SECURES INTO BAGGER COVER
 (B) CLIP
 (C) CROWN LOCKNUT (FROM PARTS BAG)
 (D) CARRIAGE BOLT, 1/4-20 x 1/2"
 (E) MOWER PAN
 (F) BOOT
 (G) HAIRPIN
 (H) WING NUT (FROM PARTS BAG)
 (I) DEFLECTOR

(J) BRACKET
 (K) BOOT CLIP
 (L) STUD
 (M) REMOVE STRAP FROM BOOT AND INSTALL ON TUBE WITH HARDWARE SHOWN
 (N) MACHINE SCREW, NO. 10 (FROM PARTS BAG)
 (O) FLANGE WHIZLOCK NUT
 (P) TUBE

FIGURE 11-12

1. Install bottom edge of boot between mower runner, if there is one, and bottom edge of mower pan. See Figure 11-12.
2. Lift deflector, position bracket into hole of boot and into pan at rear of discharge opening area. Install boot clip from inside mower pan so stud protrudes through pan, boot and bracket at forward hole of boot and bracket. See Figure 11-12.
3. Secure boot and bracket with wing nut; tighten to stud of boot clip. Bracket also holds mower pan deflector up and away from boot when installed. See Figure 11-12.

4. Assemble and install tube as shown in Figure 11-12.



CAUTION: BE SURE THE BOOT AND TUBE ARE PROPERLY ASSEMBLED AND SECURED PRIOR TO OPERATING THE MOWER.

GRASS BAGGER MODELS 827020 AND 827021

INSTALLATION

BASKET INSTALLATION — FIGURE 11-13

1. Install grass bagger baskets as shown in Figure 11-13.
2. Grass bagger baskets are designed to allow the use of standard heavy-weight trash bags as liners. The bags may be placed in the baskets and wrapped over the edges of the baskets.
3. Close cover and secure with hook into eye bolt.

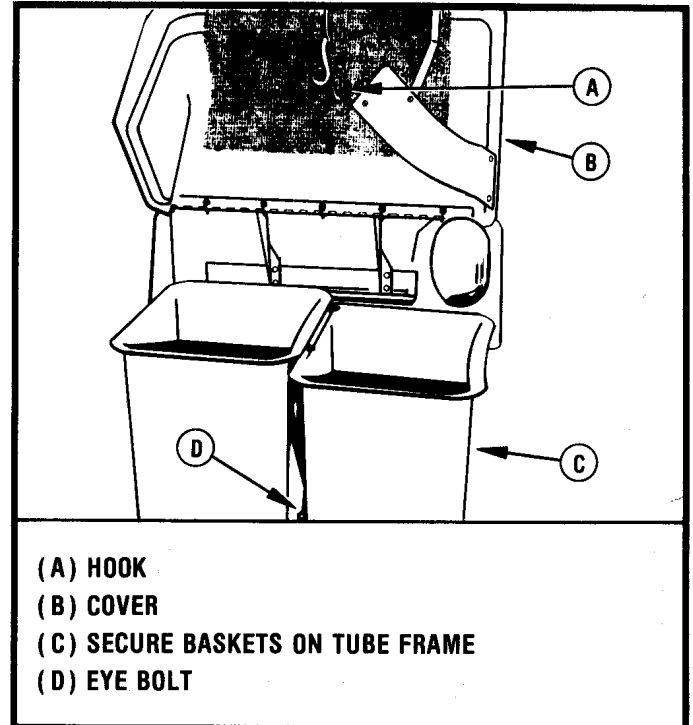

FIGURE 11-13

OPERATION

OPERATING TIPS

1. When starting to cut with the grass bagger in place, start at a slower than normal ground speed but with Throttle set for high engine speed. Use the Riding Mower Speed Control Lever to increase speed slowly (by shifting up in gears one speed at a time) for best cutting and bagging action. The heavier and damper the grass, the slower the ground speed that should be used.
2. Grass bagger baskets are designed to allow the use of standard heavy-weight trash bags as liners. The bags may be placed in the baskets and wrapped over the edges of the baskets.
3. With lush, extra heavy or damp grass, it may be necessary to make two passes of cutting operation. First cut at maximum cutting height from ground surface, then recut at the lower setting. When the trash bag liners (if used) are full, they may be tied up while in the basket, then lifted from the basket for disposal. It may be easier to remove the full liners by laying the basket on its side and pulling out the full liners.
4. If the bagger tube plugs, momentarily stop the unit and allow it to clear itself.



CAUTION: IF THE TUBE DOES NOT CLEAR ITSELF, DISENGAGE THE MOWER CLUTCH AND STOP THE RIDING MOWER ENGINE BEFORE ATTEMPTING TO CLEAR IT BY HAND.

5. Successful grass bagging operation results from the thoughtful management of several variables. Wet grass cannot be properly collected and the operator may be required to slow down. To achieve the desired results, please read and follow these recommendations:
 - a. Bagger will work best in dry grass. Between 10 a.m. and 6 p.m. would be an ideal time, after dampness has left in the morning but before evening dew.
 - b. Use full throttle setting on the Riding Mower at all times, since this gives better air flow in the grass bagger.
 - c. Try different travel speeds. Generally, first to third speeds are best unless grass is very thin and dry.

HIGH PERFORMANCE FLANGES (SUPPLIED WITH GRASS BAGGER FOR 30'' AND 32'' MODELS)

High performance flanges are supplied to fit 30'' and 32'' Ariens Riding Mowers. These flanges provide cleaner grass pick-up and more efficient grass bagging. The improved air flow they

OPERATION

HIGH PERFORMANCE FLANGES (CONTINUED)

provide enables better bagging of the taller, finer grasses and allows operation in wetter conditions. In general, broad-leaf and shorter grasses can be cut and bagged without these high performance components.

NOTE: THE SPECIAL MOWER FLANGE ASSEMBLY WILL SLIGHTLY REDUCE THE WIDTH OF CUT UNDER NORMAL CONDITIONS.

VANE SERVICE ASSEMBLY (SUPPLIED WITH GRASS BAGGER)—SEE FIGURE 11-14

Vanes are designed to provide increased air flow generally needed along with high performance flange assemblies for the more difficult bagging conditions. Vanes are designed for use on all later model Ariens Riding Mowers. See your **Ariens Dealer**.

Ariens recommends that the user try the mower without vanes first and if the performance is satisfactory, use without vanes since the vanes use more power and generate more noise. Use vanes, Service Assembly Part No. 527011, only if satisfactory performance cannot be obtained without them. Generally, broad-leaf grasses can be cut and bagged without vanes. The finer grasses may require vanes. In extremely wet conditions, vanes may also be of help.

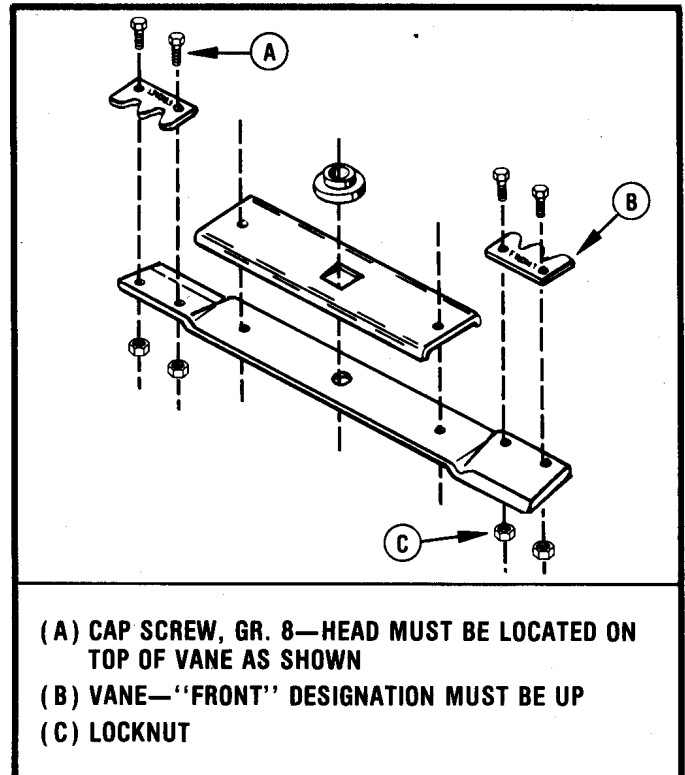

- (A) CAP SCREW, GR. 8—HEAD MUST BE LOCATED ON TOP OF VANE AS SHOWN
 (B) VANE—"FRONT" DESIGNATION MUST BE UP
 (C) LOCKNUT

FIGURE 11-14

ADJUSTMENTS/MAINTENANCE

MOWER BLADE AND VANES

NOTE: REFER TO YOUR OWNER'S MANUAL FOR REPLACEMENT OF BLADES AND VANES AS WELL AS MOWER ADJUSTMENT PROCEDURES FOR BEST GRASS CUTTING PERFORMANCE. READ SAFETY INSTRUCTIONS FOR TIPPING UNIT ONTO SERVICE BAR BEFORE ATTEMPTING UNDERSIDE ADJUSTMENTS OR MAINTENANCE.

Check tire pressure. Uneven tire pressure may cause uneven grass cutting.

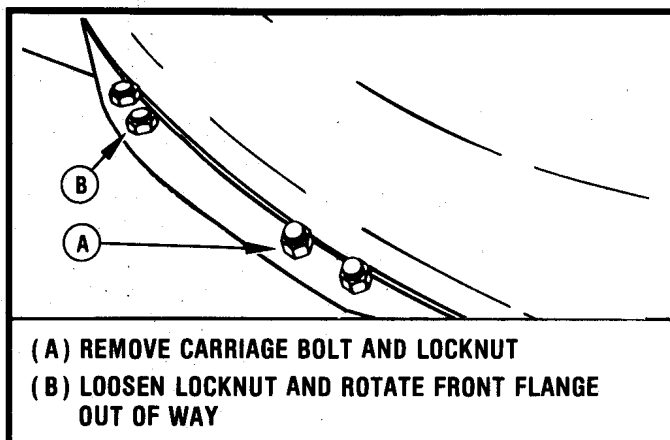

- (A) REMOVE CARRIAGE BOLT AND LOCKNUT
 (B) LOOSEN LOCKNUT AND ROTATE FRONT FLANGE OUT OF WAY

FIGURE 11-15

Routinely check for wear on the mower blade and vanes, if used. This is especially true in sandy soil conditions.

To change the mower blade on 30'' and 32'' models (equipped with flanges), remove one locknut that secures the front flange to the mower pan. Loosen the other locknut until the front flange can be rotated out of the way. See Figure 11-15.

Replace worn parts with Ariens original grass bagger components, blade, vanes, and Grade 8 hardware as specified. See your **Ariens Dealer**. Cap screws must be installed with heads on top of the vanes and vanes on top of the blade. See Figure 11-14.

IMPORTANT: THE VANES, SERVICE ASSEMBLY PART NO. 527011, MUST BE USED IN PAIRS. THEY SHOULD NOT BE INTERCHANGED WITH DIFFERENT OR WORN VANES ON THE SAME BLADE. USING ONE OF EACH OF A DIFFERENT TYPE OR WORN VANE WILL CAUSE THE BLADE TO BE OUT-OF-BALANCE AND SEVERE VIBRATION MAY OCCUR.



CAUTION: PERIODICALLY CHECK THE CONDITION OF THE FLANGE ASSEMBLY (30'' AND 32'' MODELS) FOR WEAR, DAMAGE OR LOOSENESS. DO NOT OPERATE MOWER WITH A DAMAGED OR LOOSE FLANGE OR BLADE ASSEMBLY. SEE YOUR ARIENS DEALER FOR REPLACEMENT PARTS — DO NOT SUBSTITUTE ANY MOUNTING HARDWARE.

GRASS BAGGER SERVICE GUIDE

PROBLEM	POSSIBLE CAUSE	CORRECTION
Grass bagger won't bag grass.	1. Worn or non-original equipment-type blade on mower.	1. Be sure the mower has a sharp Ariens blade on it.
	2. Low tip speed on blade.	2. Check engine RPM and increase to a maximum of 3300 RPM, decrease ground speed.
	3. High ground speed on mower.	3. Shift to lower speed.
	4. Grass conditions.	4. Grass must be dry.
	5. Discharge chute clogging due to mower pan attitude.	5. Mower pan must hang level side-to-side and 1/8''-3/8'' lower in front than back.
	6. Belt tension not properly adjusted.	6. Adjust belt tension according to Owner's Manual and conditions.
	7. Vanes required	7. Use Vane Service Assembly supplied with your grass bagger. Use only Grade 8 hardware provided.

BASIC CONSUMER-USER SERVICE COMPONENTS

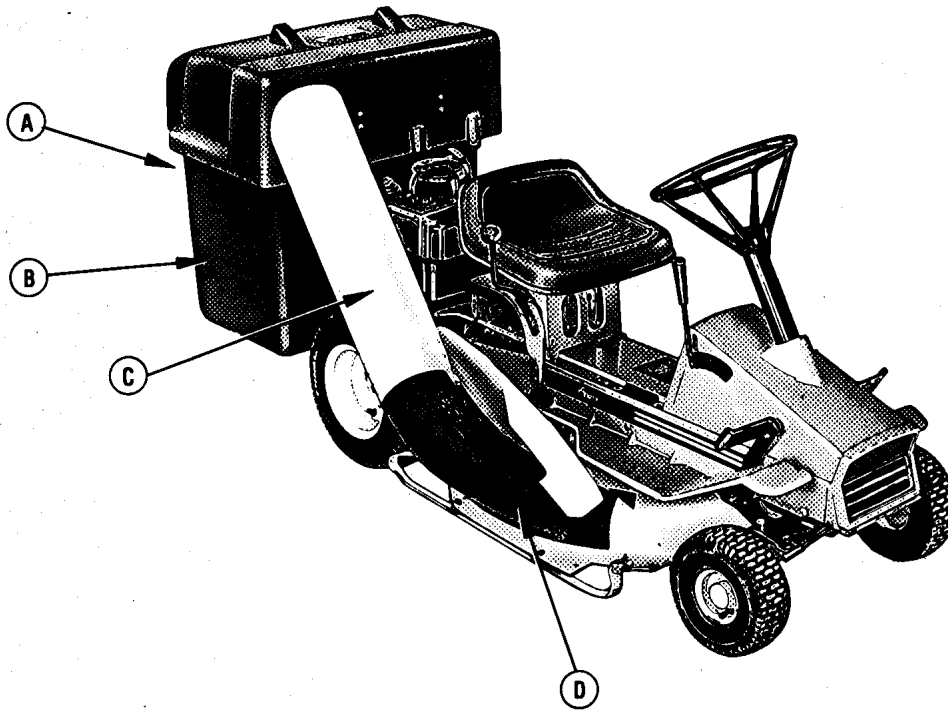

- (A) HOOK (027257)
- (B) BASKET—EACH (027244)
- (C) 26'' AND 30'' TUBE (027309)
32'' TUBE (027310)
- (D) 26'' AND 30'' BOOT—COMPLETE ASSEMBLY (627084)
32'' BOOT—COMPLETE ASSEMBLY (627090)

NOTE: FOR 30'' AND 32'' FLANGE SERVICE ASSEMBLY PARTS (PLUS 30'' BLADE TRAY) REFER TO THE EXPLODED VIEW (FIGURE 11-2) OF THIS MANUAL. FOR VANE SERVICE ASSEMBLY PARTS, ORDER PART NO. 527011. ASSEMBLY CONSISTS OF TWO VANES PLUS MOUNTING HARDWARE.

VANE SERVICE ASSEMBLY (527011)

927

NOTE: TWO VANES (027226), FOUR CAP SCREWS (059206), AND FOUR LOCKNUTS (065145) ARE SUPPLIED WITH EACH VANE SERVICE ASSEMBLY (527011).

Install the vane on top of blade. "FRONT" is stamped in the part and this must be "UP". Install the cap screws from the top down and secure with the locknuts on the bottom.

Always install the vanes in pairs and use only the Grade 8 hardware as provided to insure proper blade balance and vane security.

IMPORTANT: WHEN USING THE VANES (027226) WITH COLLECTOR MODEL 827002, YOU MUST INSTALL A SCREEN UPDATE SERVICE ASSEMBLY IN THE BUCKET ASSEMBLY. THIS SERVICE ASSEMBLY IS AVAILABLE FROM AN AUTHORIZED ARIENS DEALER.

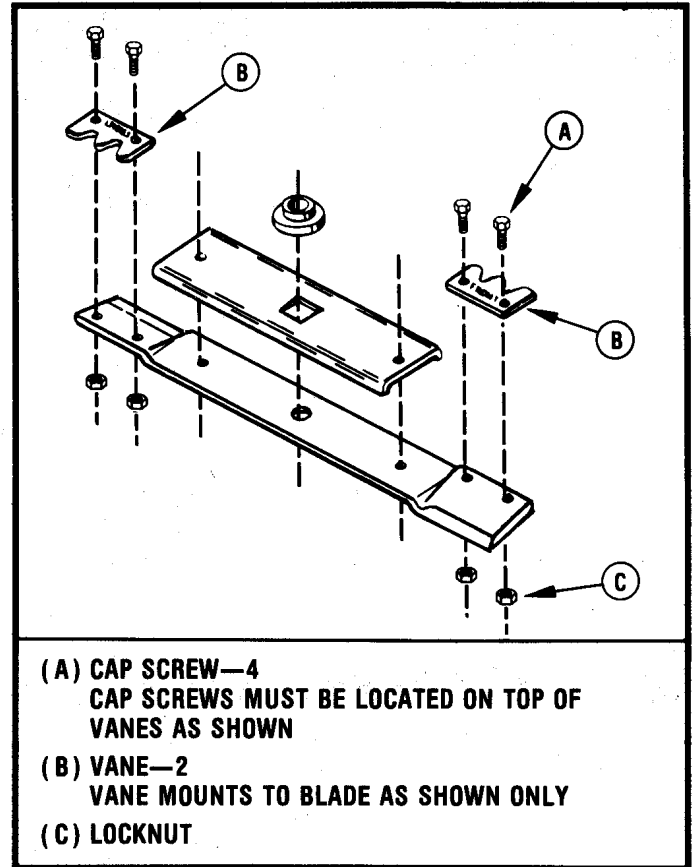

SCREEN UPDATE SERVICE ASSEMBLY (527013)

NOTE: SERVICE ASSEMBLY (527013) IS REQUIRED FOR COLLECTOR MODEL 827002 WHEN VANE SERVICE ASSEMBLY (527011) IS USED.

Position the screen (027230) along the left side (looking at inside of bucket as shown in illustration) of the existing screen and align the screen on top with the existing screen. Attach the new screen to the existing screen with the hardware provided. Place one washer on either side of the screens and install the locknut on the outside.

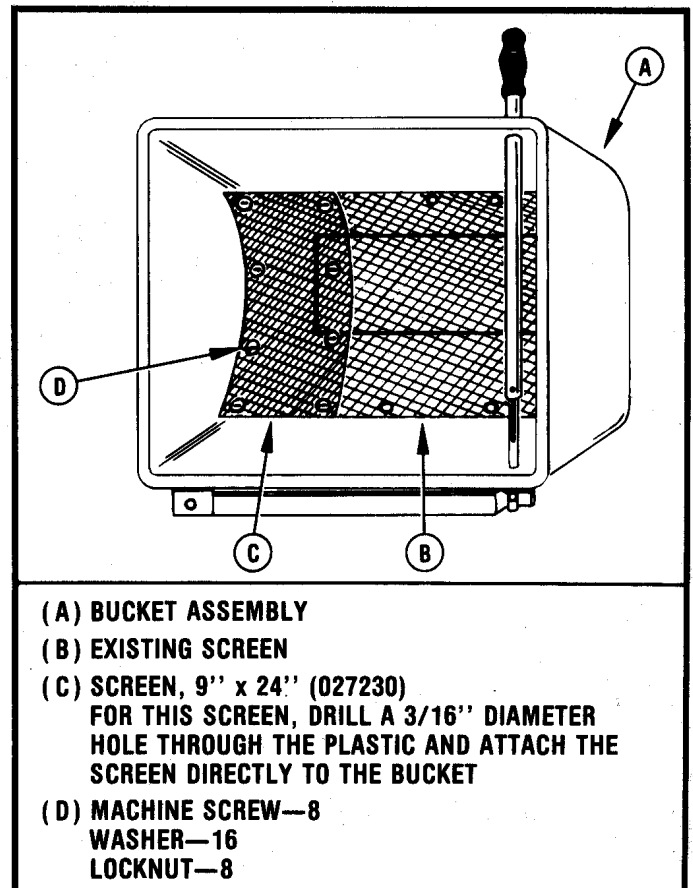

SPRING AND LINK PARTS PACKAGE (527017)

INSTALLATION

This package is designed for use on 32" mowers and is intended to correct mower belt slippage problems experienced in heavy duty operation. For use with 927000 Riding Mowers equipped with 32" mowers only (Model No's 927005, 6, 7 and 8).



CAUTION: WHEN MAKING ANY ADJUSTMENT OR REPAIRS REMOVE SPARK PLUG WIRE. TO AVOID SPILLING BATTERY ACID OR FUEL WHEN MAKING REPAIRS OR ADJUSTMENTS REQUIRING ACCESS TO THE BOTTOM OF THE UNIT, BE SURE TO REMOVE THE BATTERY AND DRAIN THE FUEL TANK BEFORE TIPPING TRACTOR ONTO SERVICE BAR. DRAIN FUEL TANK BY REMOVING FUEL LINE AT CARBURETOR OR FUEL TANK, WHICHEVER IS EASIER. AFTER FUEL TANK IS DRAINED, RUN ENGINE TO REMOVE REMAINING FUEL IN CARBURETOR. REMOVE AIR CLEANER ELEMENT. FAILURE TO FOLLOW THESE PRECAUTIONS WILL RESULT IN THE AIR CLEANER ELEMENT BECOMING SOAKED WITH FUEL, PICKING UP DIRT AND CHOKING THE ENGINE. THE FUEL DRAWN INTO THE CYLINDER AND WASHING THE CYLINDER WALLS WILL ALSO SHORTEN ENGINE LIFE.

SERVICE ASSEMBLY CONSISTS OF:

1. LINK (027271)
2. COMPRESSION SPRING (083191)
3. WASHER (064002)
4. COTTER PIN (067024)
5. WASHER (064079)

1. Set Mower Height Lever to lowest cutting height position and Mower Clutch in "OUT" position.
2. Tip the Riding Mower onto service bar.
3. Remove hairpin securing the positioning arm and move the arm out of the way for access to the spring and link area.
4. Using a 1/2" wrench, remove the locknut (A). Rod pivot (E), bushing (P), wave washer (C) and washer (Q) may now be removed from the idler arm (B).
5. Make sure Mower Height Lever is in lowest cutting height position and Mower Clutch is in "IN" position. Remove the cotter pin (K) from the end of the clutch rod (O). When the cotter pin is removed, the clutch rod, compression spring (G), and washer (H) may be removed from the pivot arm (J).
6. Remove and retain the locknut (D) from the assembly. The locknut, washer (H), rod pivot (E), bushing (P), wave washer (C), washer (Q) and locknut (A) must be retained for use with the new parts.
7. Assemble the new parts supplied with the service assembly: new link in place of clutch rod (O), new washer (F) at end of new spring, and new spring in place of old spring (G). Make sure parts are assembled as shown with old parts as described in item 6.

8. Attach the new spring and link assembly to the rod pivot (E) with the locknut (D). Make sure new washer (F) is installed between new spring and rod pivot. By turning the locknut (D), adjust the spring tension for no slack.
9. Attach this complete assembly to the idler arm (B) with bushing (P), locknut (A), washer (Q) and wave washer (C) as shown in the illustration..
10. A new cotter pin (K) and washer (I) is supplied with the service assembly. This will secure the new link (O) end to the pivot arm (J).
11. Replace the positioning arm and hairpin.

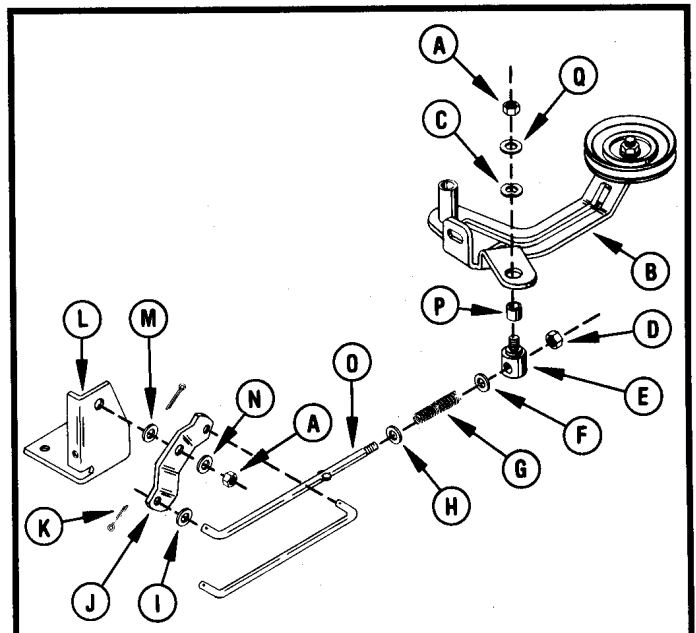

- (A) LOCKNUT, 5/16-18
- (B) IDLER ARM
- (C) WAVE WASHER
- (D) LOCKNUT, 3/8-16
- (E) ROD PIVOT
- (F) WASHER, .370/.390" x .875" x .083" (064002)
- (G) COMPRESSION SPRING (083191)
- (H) WASHER
- (I) WASHER, .339/.359" x 1.125" x .063" (064079)
- (J) PIVOT ARM
- (K) COTTER PIN, 3/32" x 1 7/8" (067024)
- (L) DECK PIVOT BRACKET
- (M) SPACER
- (N) WASHER, 5/16" ID x 1 1/8" OD x 1/16"
- (O) CLUTCH ROD (027271)
- (P) SPACER BUSHING
- (Q) WASHER, .370/.390" x .875" x .083"

INSTALLATION

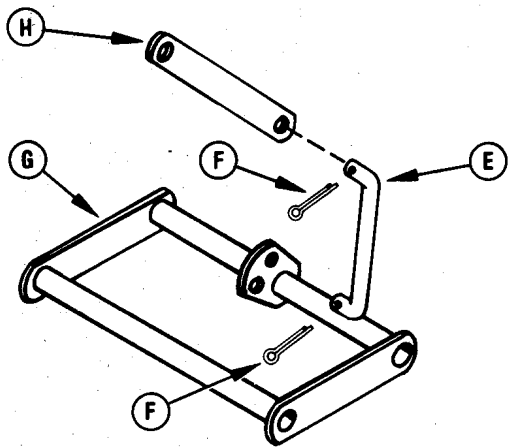
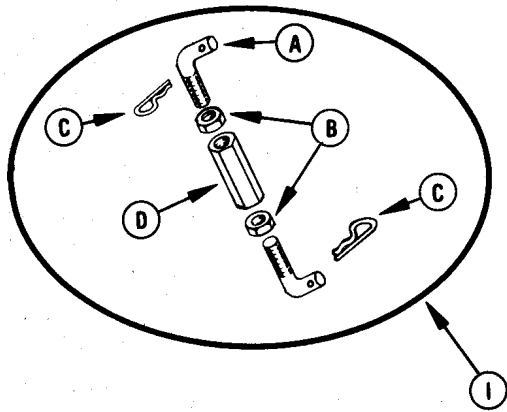

- (A) FRONT LIFT LINK
- (B) JAM NUT
- (C) HAIRPIN
- (D) COUPLING NUT
- (E) EXISTING FRONT LIFT LINK
- (F) EXISTING COTTER PINS (DO NOT RE-USE)
- (G) FRONT LIFT ARM
- (H) STRAP
- (I) NEW FRONT LIFT LINK



FIGURE 12-1A

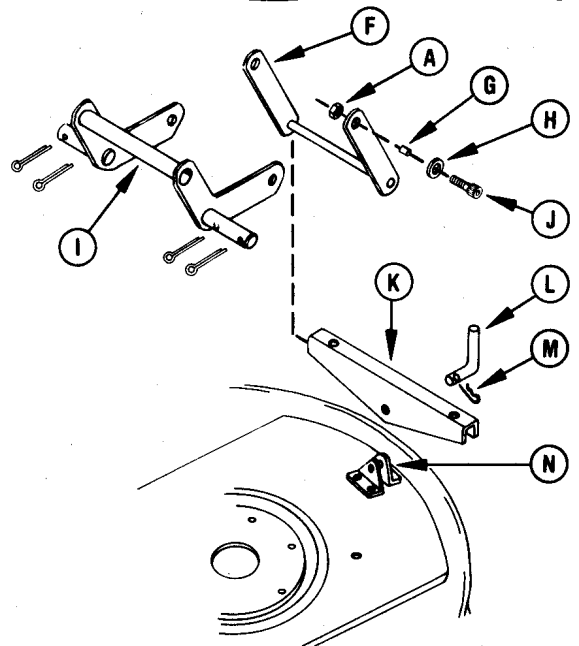
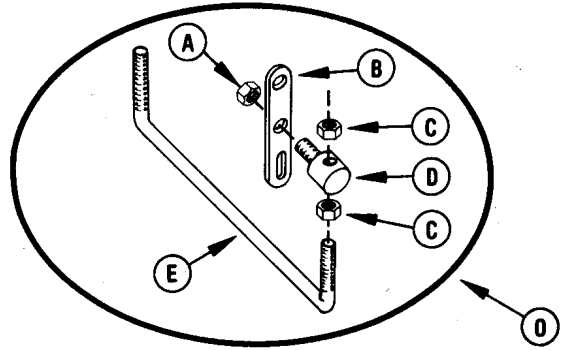

- (A) LOCKNUT, 5/16-18
- (B) REAR LIFT LINK
- (C) JAM NUT, 3/8-16
- (D) ROD PIVOT
- (E) REAR LIFT ROD
- (F) EXISTING REAR LIFT LINK
- (G) SPACER BUSHING
- (H) WASHER
- (I) REAR MOWER HANGER
- (J) SOCKET-HEAD SCREW
- (K) SWIVEL BRACKET
- (L) PIN
- (M) HAIRPIN
- (N) MOUNTING BRACKET
- (O) NEW REAR LIFT LINK

FIGURE 12-1B

FIGURE 12-1

HEIGHT ADJUSTMENT SERVICE ASSEMBLY (527018) RETRO-FIT

For Models 927001, 2, 4, 5, 6, 7, 8, and 14 and 1980-81 Models 927003, 9, 10, 11, 12, 13, 15, and 16 manufactured prior to November, 1980.

SERIAL NUMBERS WITH LINKS:

927003 (0340+)	927012 (0101+)
927009 (0040+)	927013 (0410+)
927010 (1005+)	927015 (0101+)
927011 (0490+)	927016 (0101+)

GENERAL

This service assembly is intended to provide a range of related mower height adjustments to satisfy requirements for variations in cutting height and blade pitch. The service assembly consists of two new lift link assemblies, a Front Lift Link Assembly (627070) and a Rear Lift Link Assembly (627071). Each assembly installs in place of the existing front and rear links and allows adjustment at these points.

NOTE: BEFORE INSTALLING THE SERVICE ASSEMBLY MAKE SURE TIRE PRESSURES ARE CORRECT. ALL FOUR TIRES SHOULD BE MAINTAINED AT 12 PSI FOR MOWING.

INSTALLATION

INSTALLATION — GENERAL



CAUTION: WHEN MAKING ANY ADJUSTMENT OR REPAIRS REMOVE SPARK PLUG WIRE. TO AVOID SPILLING BATTERY ACID OR FUEL WHEN MAKING REPAIRS OR ADJUSTMENTS REQUIRING ACCESS TO THE BOTTOM OF THE UNIT, BE SURE TO REMOVE THE BATTERY AND DRAIN THE FUEL TANK BEFORE TIPPING TRACTOR ONTO SERVICE BAR. DRAIN FUEL TANK BY REMOVING FUEL LINE AT CARBURETOR OR FUEL TANK, WHICHEVER IS EASIER. AFTER FUEL TANK IS DRAINED, RUN ENGINE TO REMOVE REMAINING FUEL IN CARBURETOR. REMOVE AIR CLEANER ELEMENT. FAILURE TO FOLLOW THESE PRECAUTIONS WILL RESULT IN THE AIR CLEANER ELEMENT BECOMING SOAKED WITH FUEL, PICKING UP DIRT AND CHOKING THE ENGINE. THE FUEL DRAWN INTO THE CYLINDER AND WASHING THE CYLINDER WALLS WILL ALSO SHORTEN ENGINE LIFE.

Tip Riding Mower onto service bar following "CAUTION" instructions above. The mower pan should be positioned for lowest cutting height to allow access to the lift link areas. Be sure to

hold deck in position (avoid dropping) when disassembling or assembling the lift link components.

The front lift link assembly may be installed first, then the rear lift link assembly.

Prior to installation of both the front lift link and rear lift link, refer to Table 2 and adjust the links to the pre-set dimensions indicated. This will ease link installation and adjustment. To set the dimensions read and follow steps 1 and 2 of "ADJUSTMENT PROCEDURE" section.

Also, prior to installation of links, check to see that the adjustment strap of your Riding Mower, if so equipped, is pre-set in the third hole. See Figure 12-2.

LINK PRE-SET DIMENSIONS		
MOWER SIZE	FRONT LINK (1)	REAR LINK (2)
26"	2 11/16"	2 1/8"
28"	3"	2 1/2"
30"	2 13/16"	2 1/2"
32"	3 1/4"	2 1/2"

TABLE 2

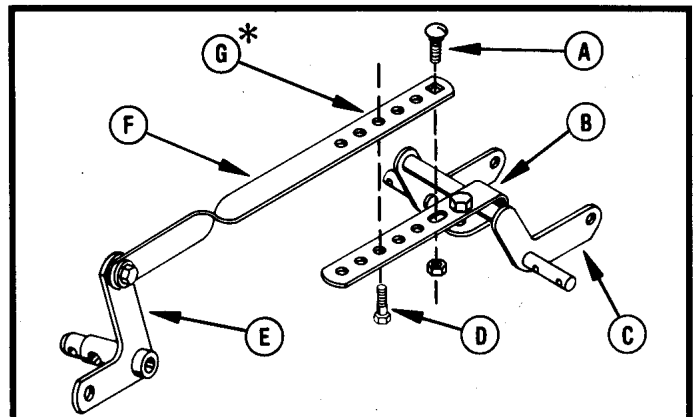
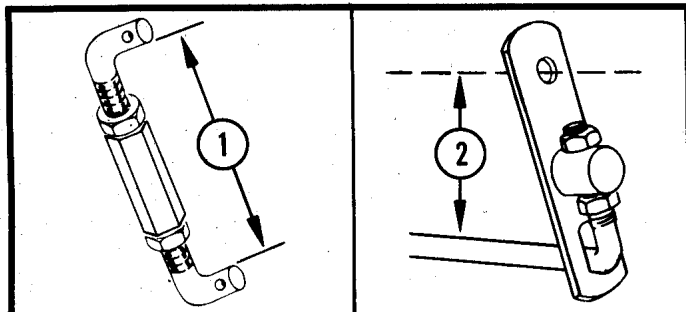

- (A) CARRIAGE BOLT—LOOSEN TO ADJUST
- (B) ADJUSTMENT STRAP
- (C) REAR MOWER HANGER
- (D) CAP SCREW—REMOVE TO ADJUST
- (E) LIFT ARM
- (F) LIFT STRAP
- (G) CAP SCREW PRE-SET POSITION

*NOTE: FOR 28" MOWERS THE PRE-SET HOLE IS THE HOLE CLOSEST TO THE CARRIAGE BOLT ADJUSTMENT SLOT IN THE ADJUSTMENT STRAP.

FIGURE 12-2

INSTALLATION

INSTALLATION—GENERAL (CONTINUED)

Once the links and adjustment strap have been pre-set the front and rear lift link assemblies may be installed. After installation check mower cutting height and blade pitch as described in "GENERAL" section of "ADJUSTMENTS/MAINTENANCE". If the pre-set dimensions are insufficient to achieve desired height and blade pitch, further adjustment may be made following the instructions provided.

FRONT LIFT LINK (627070) INSTALLATION

Refer to Figure 12-1 and remove the existing front lift link as follows:

1. Remove the existing cotter pins from each end of the existing front lift link.
2. Remove front link lift arm and strap.

Position new front lift link assembly (627070) in place of front lift link removed. Make sure the lower end of the link is installed in the forward hole of the mounting area of the front lift arm. Complete the installation as follows. See Figure 12-3.

1. Insert a hairpin, supplied, through the hole of the upper link to secure the link to the strap.
2. Insert hairpin through the hole of the lower link to secure the link to the front lift arm. See Figure 12-3.

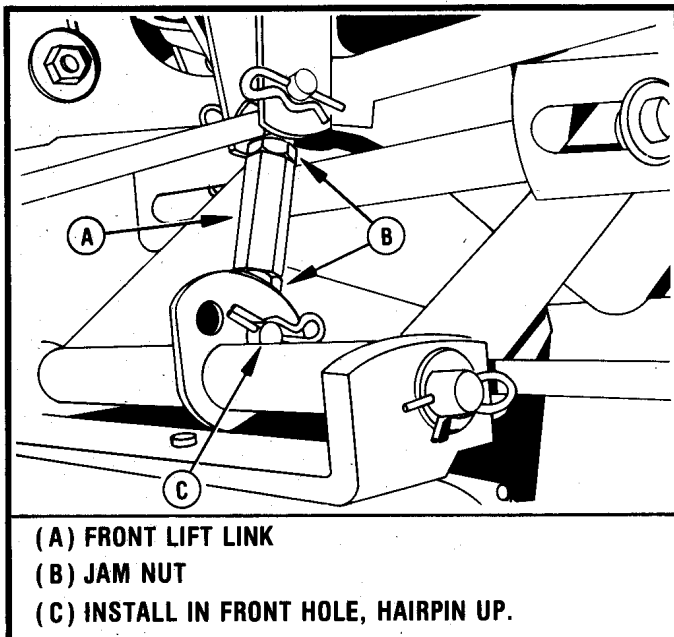

FIGURE 12-3

REAR LIFT LINK (627071) INSTALLATION

Refer to Figure 12-1, for reference in the removal of the existing rear lift link. Proceed with the following steps:

1. Remove the hairpin from the pin securing the swivel bracket to the mounting brackets on the mower pan. Save all parts for future use.
2. Lift out the swivel bracket to free the lower portion of the existing rear lift link.
3. Remove the socket-head screws (with 3/16" allen wrench), locknuts (with 1/2" wrench), washers, and spacer bushings securing each side of the existing rear lift link to the rear mower hanger. Make sure to save all parts except the existing rear lift link for future use.

Refer to Figure 12-1 and Figure 12-3 for installation.

Position new rear lift link assembly (627071) in place of the rear lift link removed. Install the original hardware (socket-head screws, washers, spacer bushings, and locknuts) through the center hole in each of the new rear lift link components of the new assembly as shown. Tighten all hardware securely.

Position lower rod portion of new rear lift link assembly as shown in Figure 12-4, in place of the old rear lift link. Position swivel bracket, pin, and hole in mower pan mounting bracket in alignment. Pin installs through these components as shown, with lower rod portion of new rear lift link assembly under swivel bracket. Install hairpin through end of the pin.

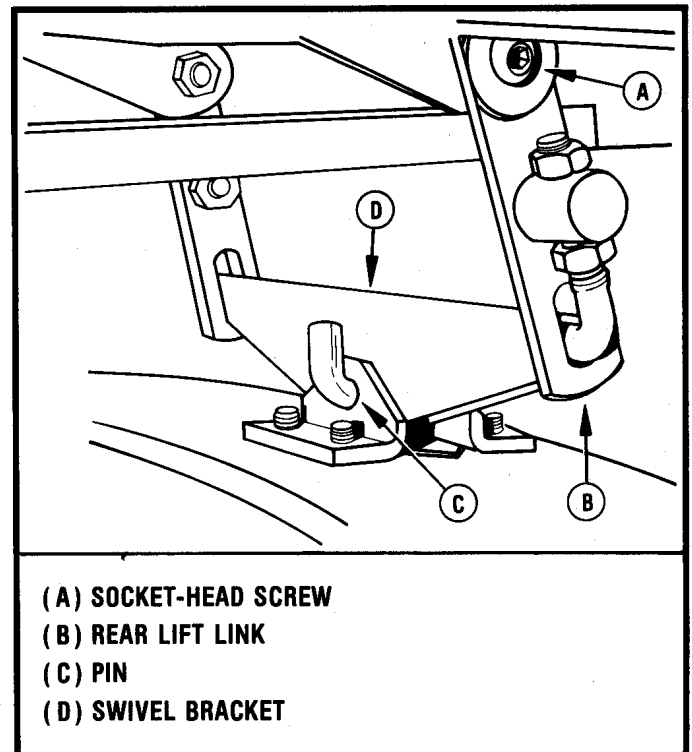

FIGURE 12-4

HEIGHT ADJUSTMENT SERVICE ASSEMBLY (527018) RETRO-FIT

INSTALLATION

NEW FRAME BRACE INSTALLATION

This frame brace is supplied to provide additional clearance for the mower engagement arm on 26", 28", and 30" mowers. It is not necessary to install this on 32" mower models.

1. Tip Riding Mower onto service bar following "CAUTION" instructions in the "INSTALLATION" section.
2. Remove existing frame brace by removing carriage bolts and flange whizlock nuts securing it to the frame. Retain hardware for installation of new brace.

3. Install new design frame brace (027052) supplied with this service assembly in place of old frame brace, using existing hardware.

NOTE: BE SURE TO POSITION THE OVAL TUBE SECTION OF THE NEW FRAME BRACE TOWARD REAR OF THE RIDING MOWER.

ADJUSTMENTS

GENERAL

NOTE: BEFORE ADJUSTING HEIGHT AND PITCH SET RIDING MOWER ON A COMPLETELY FLAT, HARD SURFACE. BE SURE TIRE PRESSURES ARE SET TO 12 PSI.

Proceed with the following steps to check the cutting height and blade pitch for your grass conditions and requirements.

1. Normally, a range of approximately 1"-4" of cutting height is possible. You may adjust this with the new lift link assemblies as described in the following "ADJUSTMENT PROCEDURE" section. In order to check your cutting height, measure the distance from the ground level to the cutting tip of the mower blade with the blade tip at the discharge opening. See Figure 12-5. Rotate the blade using a glove or padding with the Mower Clutch disengaged, "OUT", and check with the Mower Height Lever in either the highest or lowest position.

2. In all cases, for proper grass cutting, the mower blade pitch must be maintained at a difference of 1/4"-3/8" between the blade tip at front and blade tip at rear. The front dimension must be 1/4"-3/8" lower than the rear. You may adjust this with the new lift link assemblies and the adjustment strap as described in the following "ADJUSTMENT PROCEDURE" section. In order to check your blade pitch measure the distances from the ground level to the cutting tips of the mower blade with the tips at the center front and center rear of the mower. Rotate the blade using a glove or padding with the Mower Clutch disengaged, "OUT", and the Mower Height Lever in the highest position. Refer to Figure 12-6. Be sure to check the front dimension from the right side and the rear dimension from the left side (as viewed from operator's position). Engage Mower Clutch before checking pitch. Be sure that tension of mower belt, when engaged, does not affect pitch-checking accuracy.

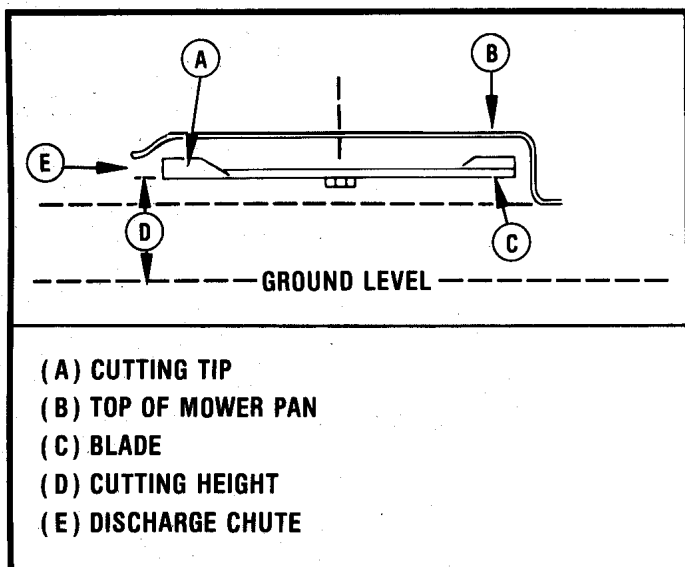

FIGURE 12-5

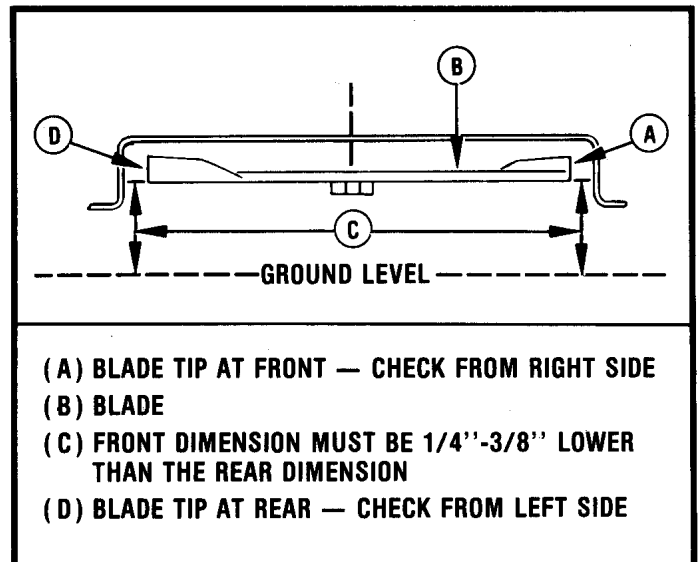

FIGURE 12-6

ADJUSTMENTS

ADJUSTMENT PROCEDURE

Read and follow "CAUTION" instructions, and tip Riding Mower onto service bar.

To adjust the cutting height or blade pitch refer to steps 1 and 2 only. To achieve a proper balance of cutting height versus blade pitch, the operator must experiment to suit the grass conditions and ground surface variations. Remember, blade pitch, as described in "GENERAL" section of "ADJUSTMENTS/MAINTENANCE", must be maintained. Keep a record of the settings on your Mower Height Lever to avoid cutting too high or too low (scalping on uneven surfaces).

1. FRONT LIFT LINK ADJUSTMENT

- After checking for the mower height and blade pitch, remove the front lift link assembly by removing the two hairpins securing it to the front lift arm and the strap. See Figure 12-1A.
- Adjust the jam nuts to allow movement of the coupling nut. By turning the two front lift links, to maintain equal threading into the coupling nut, the length of the complete front lift link may be extended or decreased. See Figure 12-7. Turn links "IN" for shorter dimension to raise mower and mower blade. Turn "OUT" to lower.
- After tightening jam nuts, replace the front lift link assembly as described in the "INSTALLATION" instructions.
- Recheck the blade pitch and cutting height.

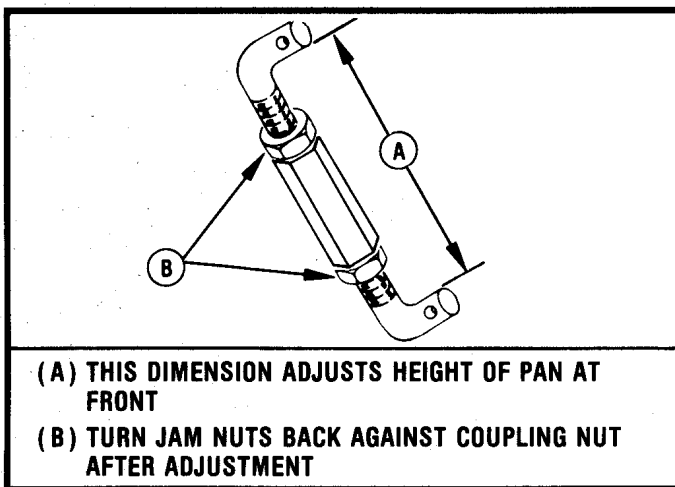

FIGURE 12-7

2. REAR LIFT LINK ADJUSTMENT

- After checking for the mower blade pitch, adjust the up or down movement of the threaded ends of the rear lift rod in the pivot by loosening the upper and

lower jam nuts. Adjust each side of the assembly equally. Refer to Figure 12-7. Retighten the jam nuts to secure the assembly together. The blade pitch, as described in "GENERAL" section of "ADJUSTMENTS/MAINTENANCE", must be maintained.

- Recheck the blade pitch and cutting height.

ADJUSTMENT STRAP

If desired results are not achieved after the links have been adjusted, reset the adjustment strap as follows:

- Following instructions in "GENERAL" section of "ADJUSTMENTS/MAINTENANCE", measure from front blade tip to ground and rear blade tip to ground. Pitch is correct when the tip is 1/4"-3/8" lower in front.
- If the measurement is not correct, remove mower pan as described in your Owner's Manual. Remove the 3/4" cap screw securing the lift strap and adjustment strap together; slide the lift strap and adjustment strap together (or apart) as required and re-install the cap screw. The holes in the lift strap are tapped, and there are five holes in both straps to provide proper adjustment.
- Recheck the blade measurements and correct as required.

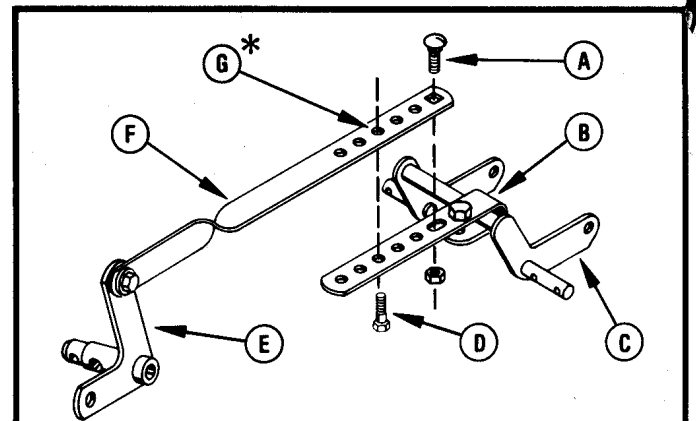

- (A) CARRIAGE BOLT—LOOSEN TO ADJUST
(B) ADJUSTMENT STRAP
(C) REAR MOWER HANGER
(D) CAP SCREW—REMOVE TO ADJUST
(E) LIFT ARM
(F) LIFT STRAP
(G) CAP SCREW PRE-SET POSITION

*NOTE: FOR 28" MOWERS THE PRE-SET HOLE IS THE HOLE CLOSEST TO THE CARRIAGE BOLT ADJUSTMENT SLOT IN THE ADJUSTMENT STRAP.

NOTE: NOT ALL UNITS HAVE THE ADJUSTABLE STRAP.

FIGURE 12-8

DRIVE PARTS PACKAGE (527029)

PACKAGE CONSISTS OF:

1. SPRING (083192)—1
2. SHIFT ARM (027038)—1
3. ENGINE SHEAVE (027010)—1
4. WASHER (064201)—1
5. WASHER (064078)—1

Refer to the instructions provided below, as well as instructions for "FRICTION WHEEL ADJUSTMENT AND REPLACEMENT" provided in this manual.

1. Replace the existing engine sheave with new style engine sheave (027010) supplied.
2. Replace the existing shift arm with new style shift arm (027038) supplied.
3. Replace the existing idler tension spring with the new spring (083192) supplied.
4. Replace present washer securing shift link to bellcrank with washer (064201) and washer (064078) supplied.
5. Locate center of the drive disc and mark with pencil.

6. Place a straight edge on surface "A" of the guard. Depress Clutch and move Speed Selector Lever to sixth speed, and then slowly pull back toward first speed (taking up all tolerances in linkage). Move until the center of the drive disc is in line with surface "A" of the guard. Stop movement and release Clutch. Disconnect ball joint. Adjust ball joint on shift rod to locate Speed Selector Lever in first speed notch of quadrant. Reconnect ball joint. Tighten nut to secure ball joint in position.

NOTE: IN SIXTH SPEED THIS WILL LOCATE THE CROWN OF THE RUBBER ON THE FRICTION WHEEL WITHIN THE EDGE OF THE DRIVE DISC. IN FIRST SPEED THE CENTERLINE OF THE FRICTION WHEEL SHOULD BE 11/16"-3/4" FROM THE CENTERLINE OF DRIVE DISC.

7. Check neutral stop to be sure it clears the clutch shaft when Clutch is released. Bend to clear if interference occurs.
8. Check Clutch and Brake adjustments. Brake should release before Clutch engages. See "ADJUSTMENTS/ MAINTENANCE" section of this manual.

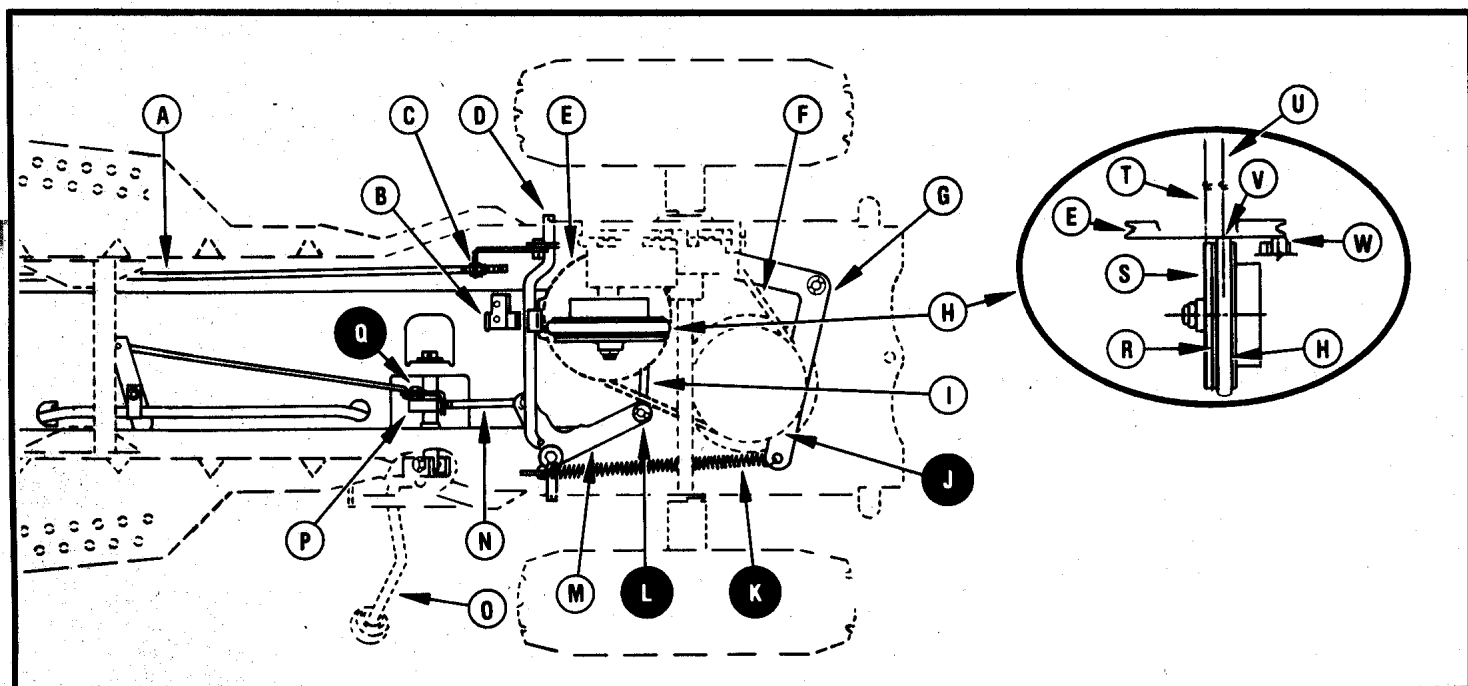

- | | |
|---|-------------------------------|
| (A) CLUTCH ROD | (M) BELLCRANK |
| (B) NEUTRAL STOP | (N) SHIFT ROD |
| (C) CLUTCH ADJUSTMENT NUT | (O) SHIFT LEVER |
| (D) CLUTCH SHAFT | (P) BALL JOINT |
| (E) DRIVE DISC | (Q) SHIFT ARM (027038) |
| (F) DRIVE BELT | (R) GUARD |
| (G) IDLER ARM | (S) GUARD SURFACE "A" |
| (H) FRICTION WHEEL WITH FIVE CAP SCREWS | (T) DRIVE DISC CENTERLINE |
| (I) SHIFT LINKS | (U) FRICTION WHEEL CENTERLINE |
| (J) ENGINE SHEAVE (027010) | (V) FIRST SPEED |
| (K) SPRING (083192) | (W) SIXTH SPEED |
| (L) WASHERS (064201 AND 064078) | |

927000 SERIES RIDING MOWER PERFORMANCE GUIDE

927

The following information describes the current Riding Mower items developed to improve grass cutting, mower height adjustment capability, and grass collecting.

Please check the model and serial numbers on the following list for applicable items when attempting to correct or improve the customer's product performance.

PERFORMANCE CONCERN	MODEL NO./SERIAL NO.		SEE ITEM NO. (Following Pages)
Belt Slippage — 32" Models	927005, 6, 7, 8	Serial No's 000101 and up	1
Mower "Scalping"	927001, 2, 4, 5, 6, 7, 8, 14 927003 927009 927010 927011 927013	All Serial No's Serial No's 000101 up to 000340 Serial No's up to 000040 Serial No's 000101 up to 001005 Serial No's 000101 up to 000490 Serial No's 000101 up to 000410	2
Bagging or Collecting/ Grass Pick-up (28", 32" Only — Older Style Mower Decks)	927001, 5, 6, 7, 8 927009, 15, 16	All Serial No's Serial No's 000101 up to 000501	3, 4
Bagging or Collecting/ Grass Pick-up (28", 30", 32" Only — Newer Style Mower Decks)	927009, 15, 16 927012, 13 927017, 20	Serial No's 000501 and up Serial No's 000101 and up Serial No's 000101 and up	4, 6

1. SPRING AND LINK PARTS PACKAGE (527017)

Pursuant to our Service Bulletin B-122 this package is designed for use on 32" mowers and is intended to correct mower belt slippage problems experienced in heavy duty operation. See Figure 13-1.

For use with 927000 Riding Mowers equipped with 32" mowers as follows:

MODEL NO.	SERIAL NO.
927005	000101 and up
927006	000101 and up
927007	000101 and up
927008	000101 and up

2. HEIGHT ADJUSTMENT SERVICE ASSEMBLY (527018) RETRO-FIT

This service assembly is intended to provide a range of related mower height adjustments to satisfy requirements for variations in cutting height and blade pitch. See Figure 13-2.

Normally, this service assembly will solve problems diagnosed by customers as "scalping", "streaking", or "digging in on corners". If these conditions exist, install Height Adjustment Service Assembly (527018).

For Models 927001, 2, 4, 5, 6, 7, 8, 14 and 1980-81 Models 927003, 9, 10, 11, 13 manufactured prior to November, 1980 with serial numbers prior to:

MODEL NO.	SERIAL NO.
927003	000340
927009	000040
927010	001005
927011	000490
927013	000410

The service assembly consists of two new lift link assemblies, a Front Lift Link Assembly, Part No. 627070, and a Rear Lift Link Assembly, Part No. 627071. Each assembly installs in place of the existing front and rear links and allows adjustment at these points.

A new frame brace is also included in this service assembly to provide additional clearance for the Mower Engagement Arm on 26", 28", and 30" Mowers. The new design frame brace and links are standard equipment for 1980-81 Model year.

927000 SERIES RIDING MOWER PERFORMANCE GUIDE

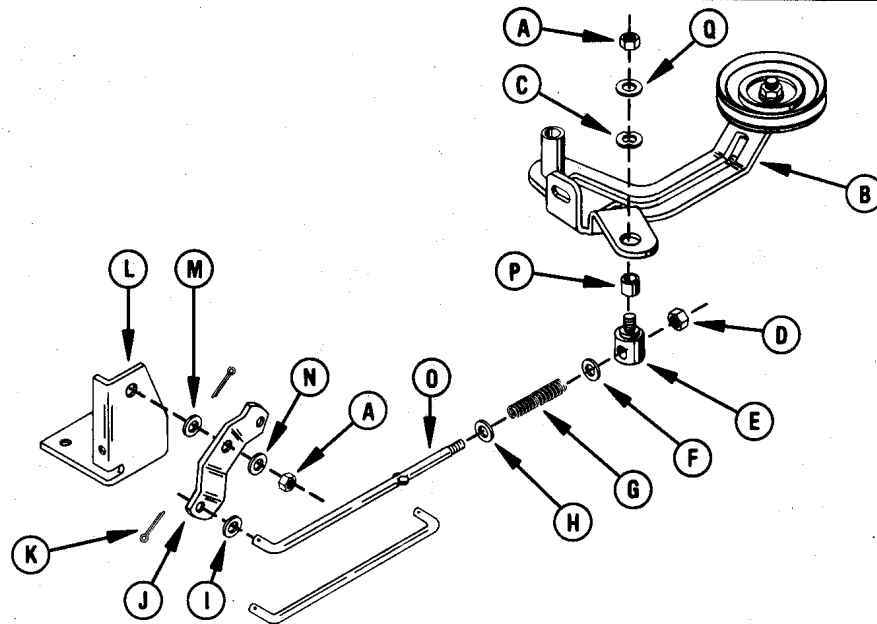

- (A) LOCKNUT, 5/16-18 (065042)
 - (B) IDLER ARM (027205)
 - (C) WAVE WASHER (003254)
 - (D) LOCKNUT, 3/8-16 (065039)
 - (E) ROD PIVOT (027206)
 - (F) WASHER, .370/.390" x .875" x .083" (064002)
 - (G) COMPRESSION SPRING (083191)
 - (H) WASHER
 - (I) WASHER, .339/.359" x 1.125" x .063" (064079)
 - (J) PIVOT ARM (027210)
 - (K) COTTER PIN, 3/32" x 1 7/8" (067024)
 - (L) DECK PIVOT BRACKET (027204)
 - (M) SPACER (010358)
 - (N) WASHER, 5/16" ID x 1 1/8" OD x 1/16" (064079)
 - (O) CLUTCH ROD (027271)
 - (P) SPACER BUSHING (006071)
 - (Q) WASHER, .370/.390" x .875" x .083"
- NOTE: THESE PARTS ARE COMPONENTS OF LATER MODEL 32" RIDING MOWERS — 1980-81 MODEL YEAR (MODELS 927012, 13, 15, 16).

FIGURE 13-1

3. HIGH PERFORMANCE ACCESSORIES MODEL 727008 (28" MOWER) AND MODEL 727009 (32" MOWER)

For use with Ariens 927000 Series Riding Mowers equipped with 28" or 32" mowers built prior to 1980-81 model year with serial numbers as follows:

MODEL NO.	SERIAL NO.
927001 — 28"	000101 and up
927009 — 28"	000101 up to 000501
927005 — 32"	000101 and up
927006 — 32"	000101 and up
927007 — 32"	000101 and up
927008 — 32"	000101 and up
927015 — 32"	000101 up to 000501
927016 — 32"	000101 up to 000501

The high performance accessories, Models 727008 and 9 are designed to improve the grass pick-up of 28" and 32" mowers when using grass bagger or collector attachments or to improve mulching when using mulching accessory on 28" mower. The accessory consists of two basic assemblies: a replacement blade assembly and a flange assembly which clamps around the lower edge of the mower pan. See Figure 13-3.

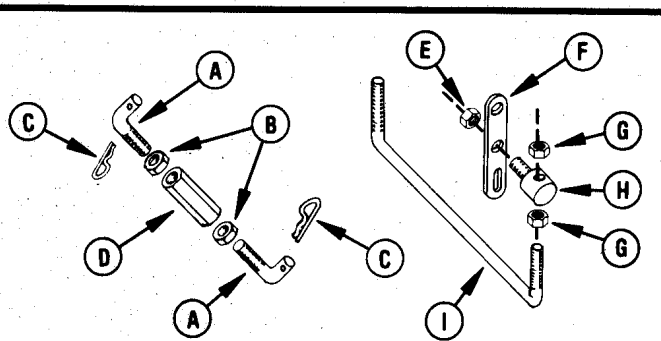

- (A) FRONT LIFT LINK (027289)
- (B) JAM NUT, 3/8-16 (065148)
- (C) HAIRPIN, 3/32 x 1-27/64" (067010)
- (D) COUPLING NUT, 3/8-16 (065147)
- (E) LOCKNUT, 5/16-18 (065042)
- (F) REAR LIFT LINK (027288)
- (G) JAM NUT, 3/8-16 (065060)
- (H) ROD PIVOT (027206)
- (I) REAR LIFT ROD (027290)

FIGURE 13-2

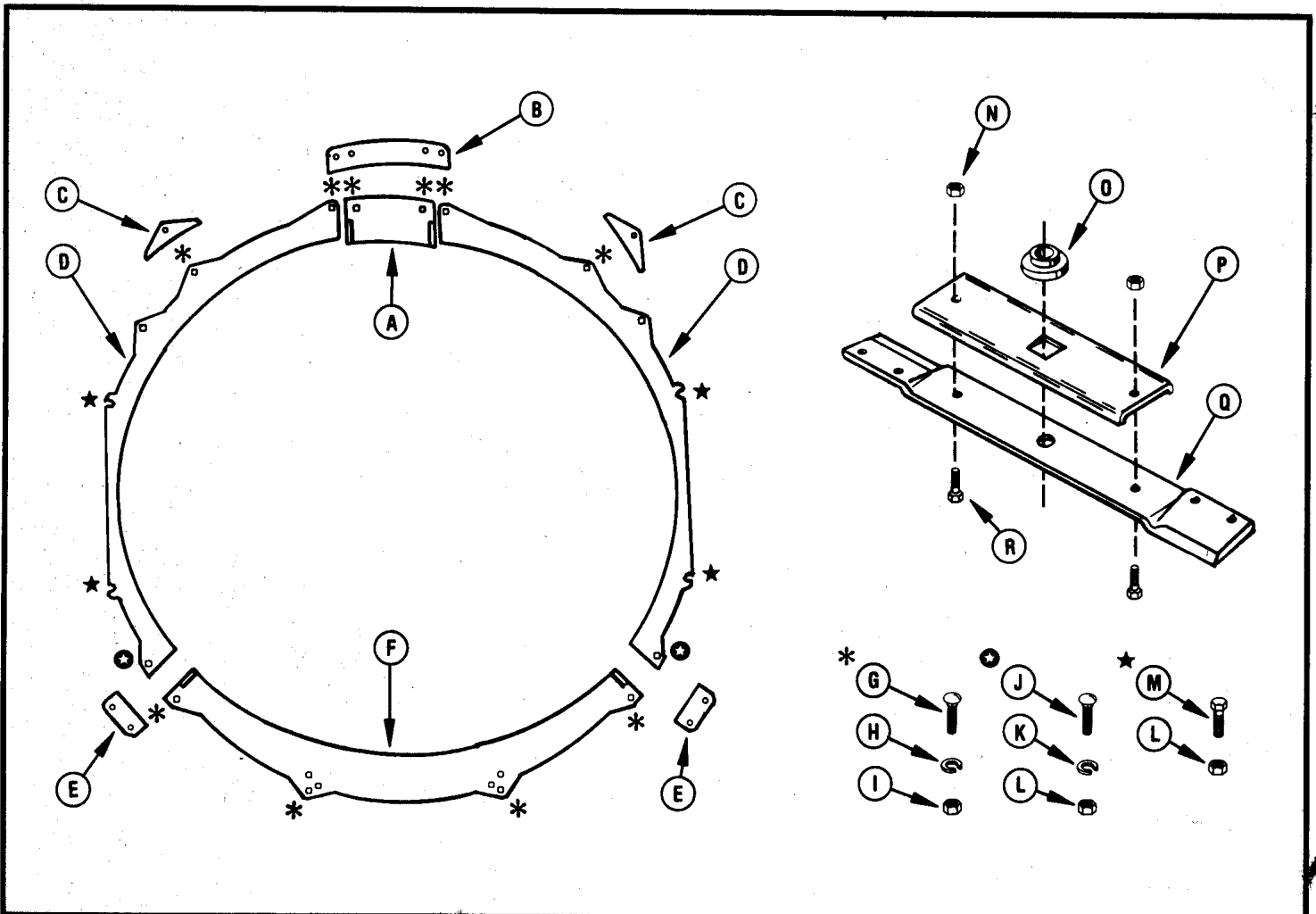

- (A) FRONT FLANGE (027277)
 - (B) FRONT CLAMP (027275)
 - (C) SIDE CLAMP (027278)
 - (D) SIDE FLANGE, 28'' (027273)
SIDE FLANGE, 32'' (027281)
 - (E) JOINT CLAMP (027276)
 - (F) REAR FLANGE (027274)
 - (G) CARRIAGE BOLT, 1/4-20 x 5/8'' (062017)
 - (H) LOCKWASHER, 5/16'' STD. (063001)
 - (I) LOCKNUT, 1/4-20 (065040)
 - (J) CARRIAGE BOLT, 5/16-18 x 5/8'' (062033)
 - (K) LOCKWASHER, 3/8'' (063004)
 - (L) LOCKNUT, 5/16-18 (065042)
 - (M) CAP SCREW, 5/16-18 x 5/8'' (059002)
 - (N) LOCKNUT, 3/18-16, GR. C. (065122)
 - (O) RETAINER HUB (031946)
 - (P) BLADE TRAY (027284)
 - (Q) MOWER BLADE, 28'' (027285)
MOWER BLADE, 32'' (027286)
 - (R) CAP SCREW, 3/8-16 x 3/4'', GR. 5 (059154)
- * DENOTES LOCATION OF THIS HARDWARE
 ● DENOTES LOCATION OF THIS HARDWARE
 ★ DENOTES LOCATION OF THIS HARDWARE

FIGURE 13-3

New blade assemblies are standard equipment on all 28'', 30'' and 32'' Riding Mowers built in 1980-81 model year as follows:

MODEL NO.	SERIAL NO.
927009 — 28''	000501 and up
927012 — 32''	000101 and up
927013 — 32''	000101 and up
927015 — 32''	000501 and up
927016 — 32''	000501 and up

The high performance accessories will provide cleaner pick-up of grass when used with an Ariens grass bagger or grass collector in most grass conditions. The accessory will also reduce blow out of clippings or debris around the bottom of the pan. The width of cut will be reduced by about 1/2'' under normal conditions. When cutting long grass, the width of cut may be reduced further.

927000 SERIES RIDING MOWER PERFORMANCE GUIDE

Ariens recommends that the user try the accessory without vanes first. If the performance is satisfactory, use without vanes since the vanes use more power and generate more noise. Use vanes only if satisfactory performance cannot be obtained without them. Generally, broad-leaf grasses can be cut and bagged without vanes. The finer grasses may require vanes. Vanes may also be of help in extremely wet conditions.

NOTE: MAKE SURE ALL HARDWARE IS TIGHT AND THERE IS 1/4"-3/8" CLEARANCE BETWEEN MOWER BLADE AND TOP OF FLANGE THROUGHOUT THE 360° BLADE TRAVEL. IF THERE IS INSUFFICIENT CLEARANCE, A NEW RETAINER HUB, PART NO. 031946, IS INCLUDED FOR INSTALLATION WITH NEW BLADES.

4. VANE SERVICE ASSEMBLY (527011)

For use on all later model Ariens Riding Mowers (models equipped with high-lift blades and mounting holes for vanes; other blades may be replaced with new high-lift blades). See Figure 13-4.

The vanes are designed to provide improved grass pick-up for bagging or collecting and may be used with the high performance accessories or the flange assemblies included with new 927000 Series Riding Mower RM Models.

Ariens recommends that the user try the mower without vanes first. If the performance is satisfactory, use without vanes since the vanes use more power and generate more noise. Use vanes only if satisfactory performance cannot be obtained without them. Generally, broad-leaf grasses can be cut and bagged without vanes. The finer grasses may require vanes. Vanes may also be of help in extremely wet conditions.

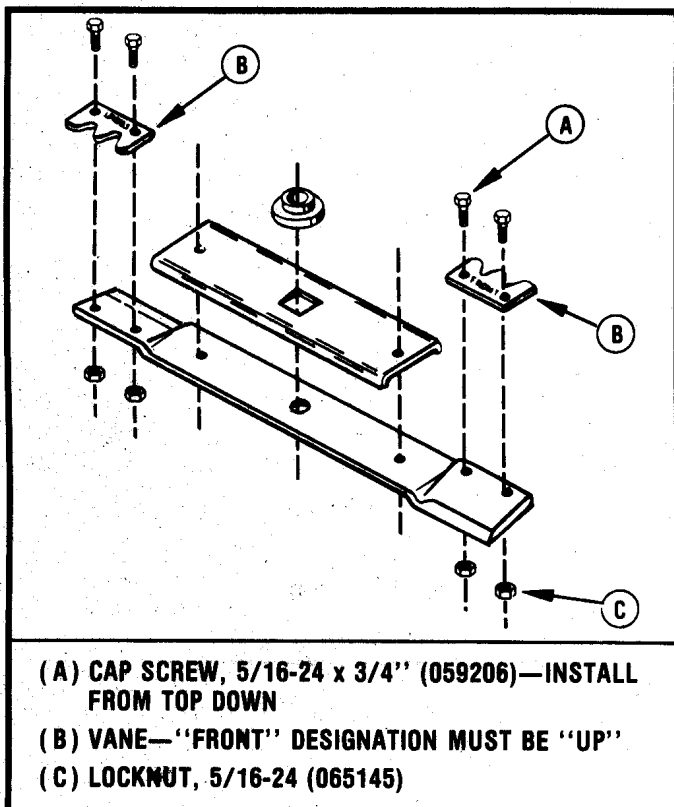

FIGURE 13-4

NOTE: TWO VANES, FOUR "GRADE 8" CAP SCREWS, AND FOUR "GRADE C" LOCKNUTS ARE SUPPLIED WITH EACH VANE SERVICE ASSEMBLY.

Install the vane on top of the blade. "FRONT" is stamped in the part and this must be "UP". Install only the Grade 8 cap screws from the top down and secure with the locknuts on the bottom.

IMPORTANT: THE VANES MUST BE USED IN PAIRS. THEY CANNOT BE INTERCHANGED WITH DIFFERENT OR WORN VANES ON THE SAME BLADE. USING ONE OF EACH OF A DIFFERENT TYPE OR WORN VANE WILL CAUSE THE BLADE TO BE OUT-OF-BALANCE AND SEVERE VIBRATION WILL OCCUR. EVEN WEAR ON THE PARTS AND PROPER BALANCE IS ENSURED BY REPLACING VANES IN PAIRS.

IMPORTANT: WHEN USING THE VANES WITH COLLECTOR MODEL 827002, YOU MUST INSTALL A SCREEN UPDATE SERVICE ASSEMBLY IN THE BUCKET ASSEMBLY. THIS SERVICE ASSEMBLY (527013) IS AVAILABLE FROM AN AUTHORIZED ARIENS DEALER.

5. SCREEN UPDATE SERVICE ASSEMBLY (527013)

Required for collector Model 827002 when vane service assembly (527011) is used. See Figure 13-5.

Service assembly includes screen and hardware for mounting to bucket assembly, re-inforcing the existing screen.

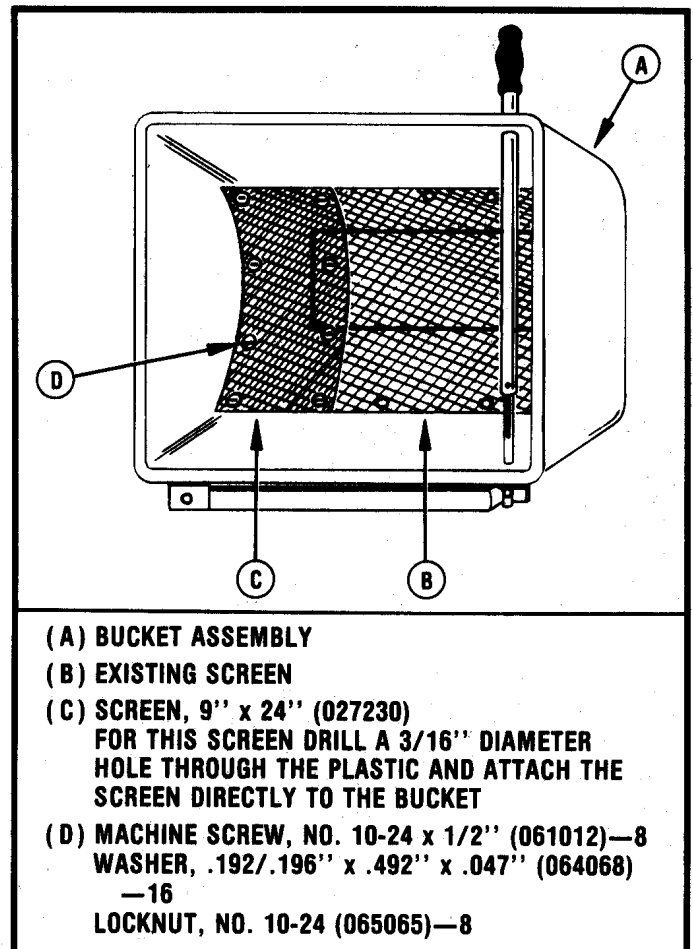

FIGURE 13-5

6. HIGH PERFORMANCE ACCESSORIES MODEL 727010 (28" MOWER), MODEL 727011 (30" MOWER) AND MODEL 727012 (32" MOWER)

For use on Ariens Riding Mowers equipped with 28", 30" or 32" Mowers as follows:	
HIGH PERFORMANCE ACCESSORY MODEL NO./SIZE	RIDING MOWER MODEL NO./SERIAL NO.
727010—28"	927009 (Serial No. 000501 and up)
727011—30"	927010 (Serial No. 001001 and up)
	927011 (Serial No. 001001 and up)
	927017 (Serial No. 000101 and up)
	927020 (Serial No. 000101 and up)
727012—32"	927012 (Serial No. 000101 and up)
	927013 (Serial No. 000101 and up)
	927015 (Serial No. 000501 and up)
	927016 (Serial No. 000501 and up)

The high performance accessories 727010, 11, and 12, are designed to improve the grass pick-up of 28", 30", and 32" Riding Mowers when using grass bagger or collector attachments or to improve mulching when using mulching accessory on 28" mower. The high performance accessories include a special flange assembly which bolts directly to the mower pan. See Figure 13-7.

IMPORTANT: WHEN USING THE HIGH PERFORMANCE ACCESSORIES, MODELS 727010, 11, and 12 USE ONLY THE NEW STYLE BLADE ASSEMBLY PARTS AS SHOWN IN THE ILLUSTRATION ON PAGE 37.

The high performance accessories will provide cleaner pick-up of grass when used with an Ariens grass bagger or grass collector in most grass conditions. The accessory will also reduce blow out of clippings or debris around the bottom of the pan. The width of cut will be reduced by about 1/2" under normal conditions. When cutting long grass, the width of cut may be reduced further.

Ariens recommends that the user try the accessory without vanes first. If the performance is satisfactory, use without vanes since the vanes use more power and generate more noise. Use vanes only if satisfactory performance cannot be obtained without them. Generally, broad-leaf grasses can be cut and bagged without vanes. The finer grasses may require vanes. Vanes may also be of help in extremely wet conditions.

NOTE: MAKE SURE ALL HARDWARE IS TIGHT AND THERE IS 1/4"-3/8" CLEARANCE BETWEEN MOWER BLADE AND TOP OF FLANGE THROUGHOUT THE 360° BLADE TRAVEL. IF THERE IS INSUFFICIENT CLEARANCE, A NEW RETAINER HUB, PART NO. 031946, IS AVAILABLE FOR INSTALLATION WITH NEW BLADES.

NOTE: FOR ARIENS SRM SERIES RIDING MOWERS, MODELS 927017, AND 20, A BLADE TRAY MUST BE INSTALLED ON THE MOWER BLADE PRIOR TO INSTALLATION OF FLANGE ASSEMBLY. IF RIDING MOWER IS NOT EQUIPPED WITH SERVICE BAR, REMOVE MOWER PAN OR RAISE RIDING MOWER ONTO RAMPS AS DESCRIBED IN THE OWNER'S MANUAL. THE BLADE SHOULD BE REMOVED, THEN CHECKED FOR WEAR AND REPLACED, IF REQUIRED, BEFORE INSTALLING BLADE TRAY. USE TWO CAP SCREWS (D) AND TWO LOCKNUTS (A) TO ASSEMBLE BLADE TRAY AND BLADE. ASSEMBLE AS SHOWN IN FIGURE 13-6.

MODEL 727011—30" BLADE REFERENCE

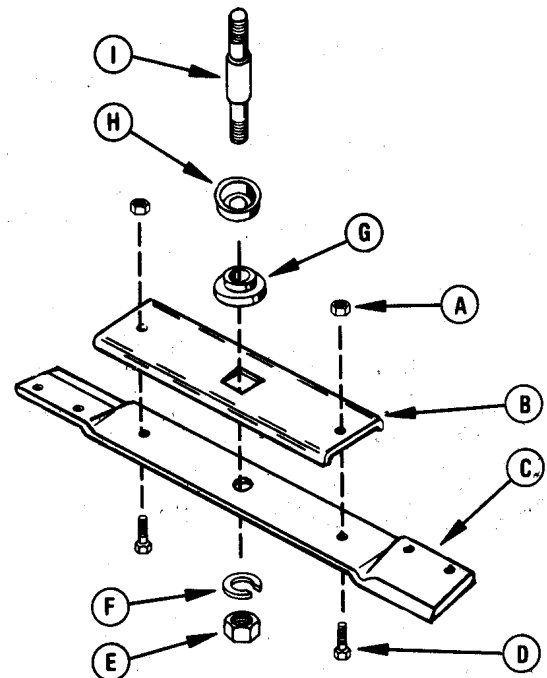

- (A) LOCKNUT, 3/8-16, GR. C (065122)
- (B) BLADE TRAY (027284)
- (C) BLADE, 30" (027287)
- (D) CAP SCREW, 3/8-16 x 3/4", GR. 5 (059154)
- (E) JAM NUT (065025)
- (F) LOCKWASHER, 3/4" (063008)
- (G) RETAINER HUB (003169)
- (H) BEARING SLINGER (003419)
- (I) SPINDLE

FIGURE 13-6

927000 SERIES RIDING MOWER PERFORMANCE GUIDE

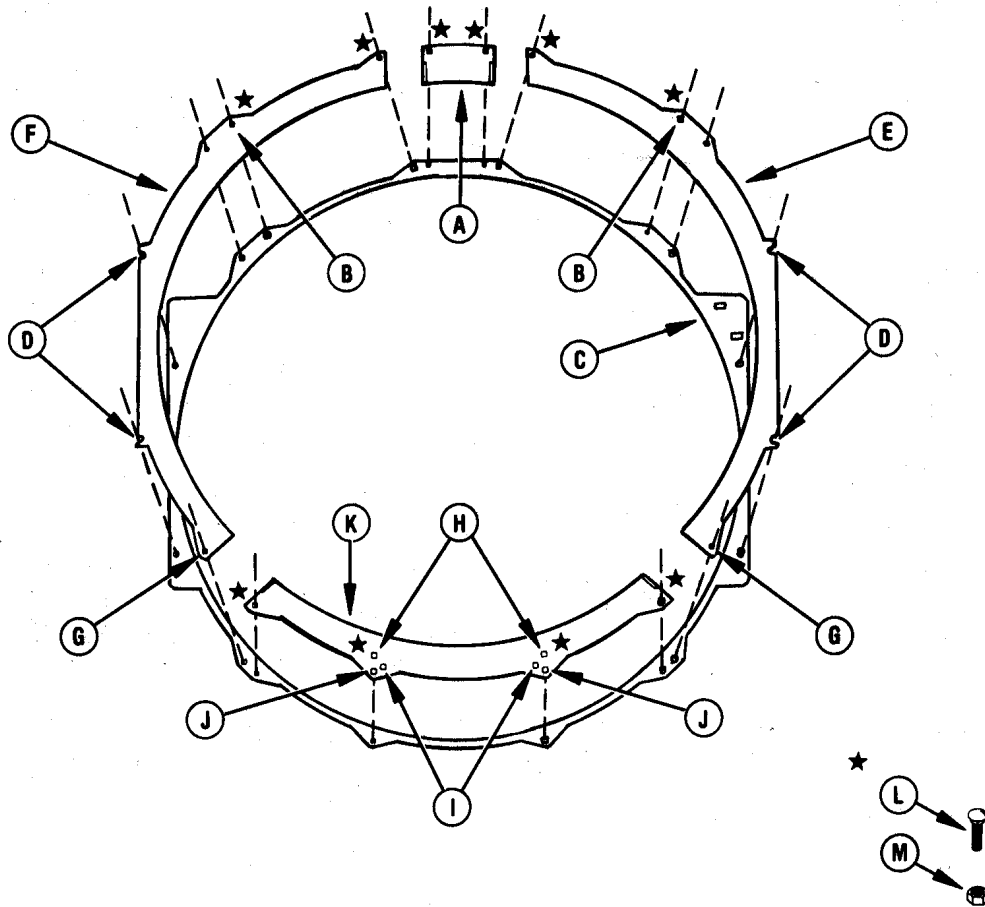

(A) FRONT FLANGE (027277)

(B) USE THIS HOLE

(C) RIM OF MOWER PAN

(D) LOOSEN AND MOUNT 28" AND 32" FLANGE WITH
RUNNER HARDWARE
(30" REQUIRES ★ HARDWARE)

(E) SIDE FLANGE, LH, 30" (027296)

(F) SIDE FLANGE, RH, 30" (027298)

(G) USE CARRIAGE BOLT, 5/16-18 x 5/8", AND
LOCKNUT, 5/16-18, HERE FOR 28" AND 30".
USE RUNNER HARDWARE FOR 32".

(H) USE THESE HOLES FOR 32"

(I) USE THESE HOLES FOR 30"

(J) USE THESE HOLES FOR 28"

(K) REAR FLANGE (027274)

(L) CARRIAGE BOLT, 1/4-20 x 5/8" (062017)
(30"—USE 14)

(M) LOCKNUT, 1/4-20 (065040) (30"—USE 14)

★ DENOTES LOCATION OF THIS HARDWARE

FIGURE 13-7