

GLP20LX, GLP25LX, GDP20LX, GDP25LX (B974) SERVICE MANUAL CONTENTS

SECTION	PART NUMBER	YRM NUMBER	REV DATE
FRAME.....	550109110	0100 YRM 1766	12/14
YANMAR DIESEL ENGINES.....	524240453	0600 YRM 1205	12/14
PSI 2.4L ENGINE.....	550108890	0600 YRM 1755	12/14
COOLING SYSTEM.....	550109111	0700 YRM 1767	12/14
FUEL SYSTEM PSI 2.4L.....	550108892	0900 YRM 1757	12/14
SINGLE SPEED PS CHAIN DRIVE PTO.....	550108495	1300 YRM 1740	12/14
DRIVE AXLE AND DIFFERENTIAL ASSEMBLY REPAIR.....	550109112	1400 YRM 1768	12/14
STEERING AXLE REPAIR.....	550109113	1600 YRM 1769	12/14
BRAKE SYSTEM.....	550108498	1800 YRM 1743	12/14
HYDRAULIC CLEANLINESS PROCEDURES.....	550073240	1900 YRM 1620	12/14
HYDRAULIC GEAR PUMPS.....	550108499	1900 YRM 1744	12/14
MAIN CONTROL VALVE.....	550108500	2000 YRM 1745	12/14
CYLINDER REPAIR (MAST S/N A698 AND A699).....	550109114	2100 YRM 1770	12/14
WIRE HARNESS REPAIR.....	524223769	2200 YRM 1128	12/14
ELECTRICAL SYSTEM.....	550109115	2200 YRM 1771	12/14
ENGINE ELECTRICAL SYSTEM, PSI 2.4L ENGINE.....	550109116	2200 YRM 1772	12/14
MAST REPAIR (S/N A698 AND A699).....	550109117	4000 YRM 1773	12/14
METRIC AND INCH (SAE) FASTENERS.....	524150797	8000 YRM 0231	10/13
PERIODIC MAINTENANCE.....	550109197	8000 YRM 1774	12/14
CAPACITIES AND SPECIFICATIONS.....	550109119	8000 YRM 1775	12/14
DIAGRAMS AND SCHEMATICS.....	550109120	8000 YRM 1776	12/14
DIAGNOSTIC TROUBLESHOOTING MANUAL.....	550022929	9000 YRM 1434	12/14

PART NO. 550109188 (12/14)

General



WARNING

The lift truck must be put on blocks for some types of maintenance and repairs. The removal of the following assemblies will cause large changes in the center of gravity: mast, drive axle, engine and transmission, and counterweight. When the lift truck is put on blocks, put additional blocks in the following positions to maintain stability:

- Before removing the mast and drive axle, put blocks under the counterweight so the lift truck cannot fall backward.
- Before removing the counterweight, put blocks under the mast assembly so the lift truck cannot fall forward.

The surface must be solid, even, and level when the lift truck is put on blocks. Make sure that any blocks used to support the lift truck are solid, one-piece units. See the Operating Manual or the Periodic Maintenance 8000YRM1774.

This section contains the description of the frame (see Figure 1 and Figure 2) and connected parts.

Procedures for removing and installing the counterweight, hood, overhead guard, engine, and cooling system are found in this section. Checks for the operator restraint system, adjustments for the throttle pedal stop, and procedures for the repair of tanks and installation of safety labels are also included.

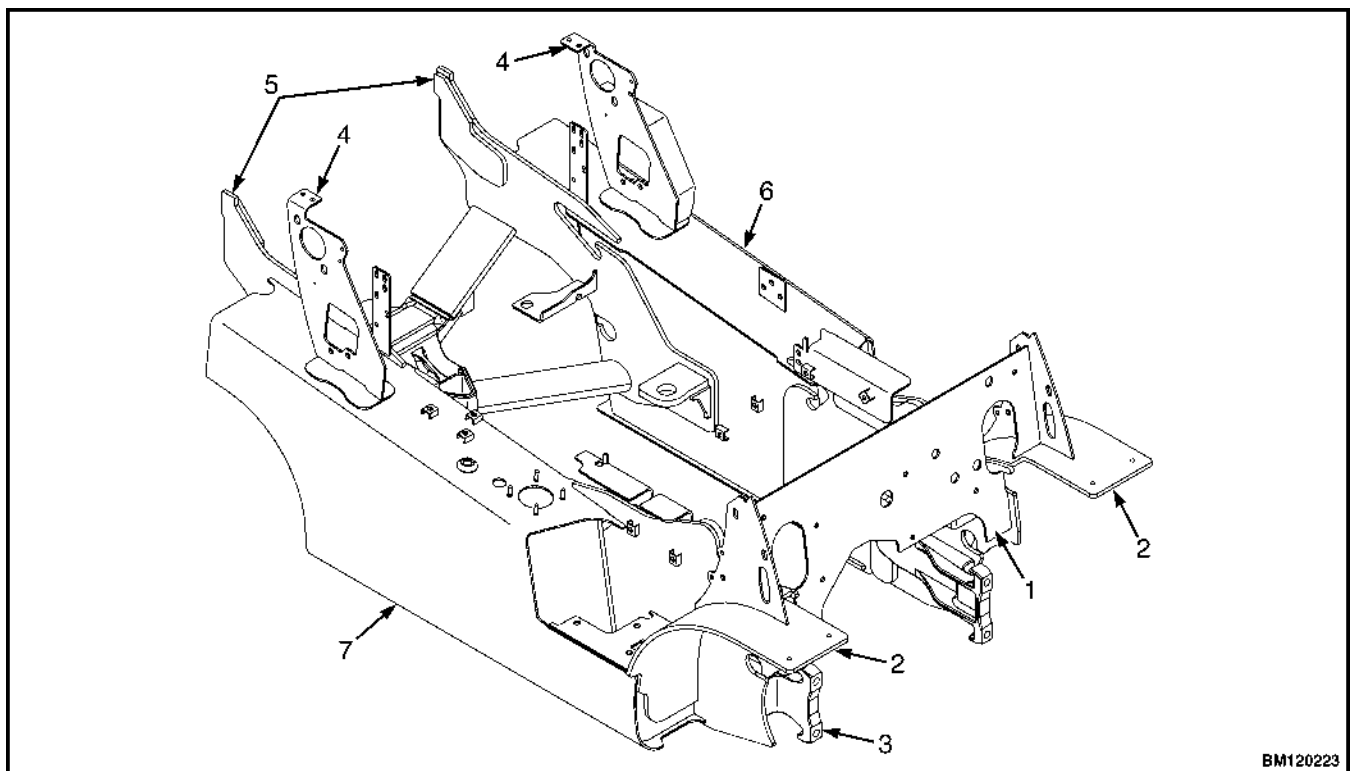

1. COWL PLATE
2. FENDER
3. FRAME
4. HOOD MOUNT

5. COUNTERWEIGHT SUPPORT
6. LEFT-HAND FRAME WELDMENT
7. HYDRAULIC TANK

Figure 1. Frame, LPG

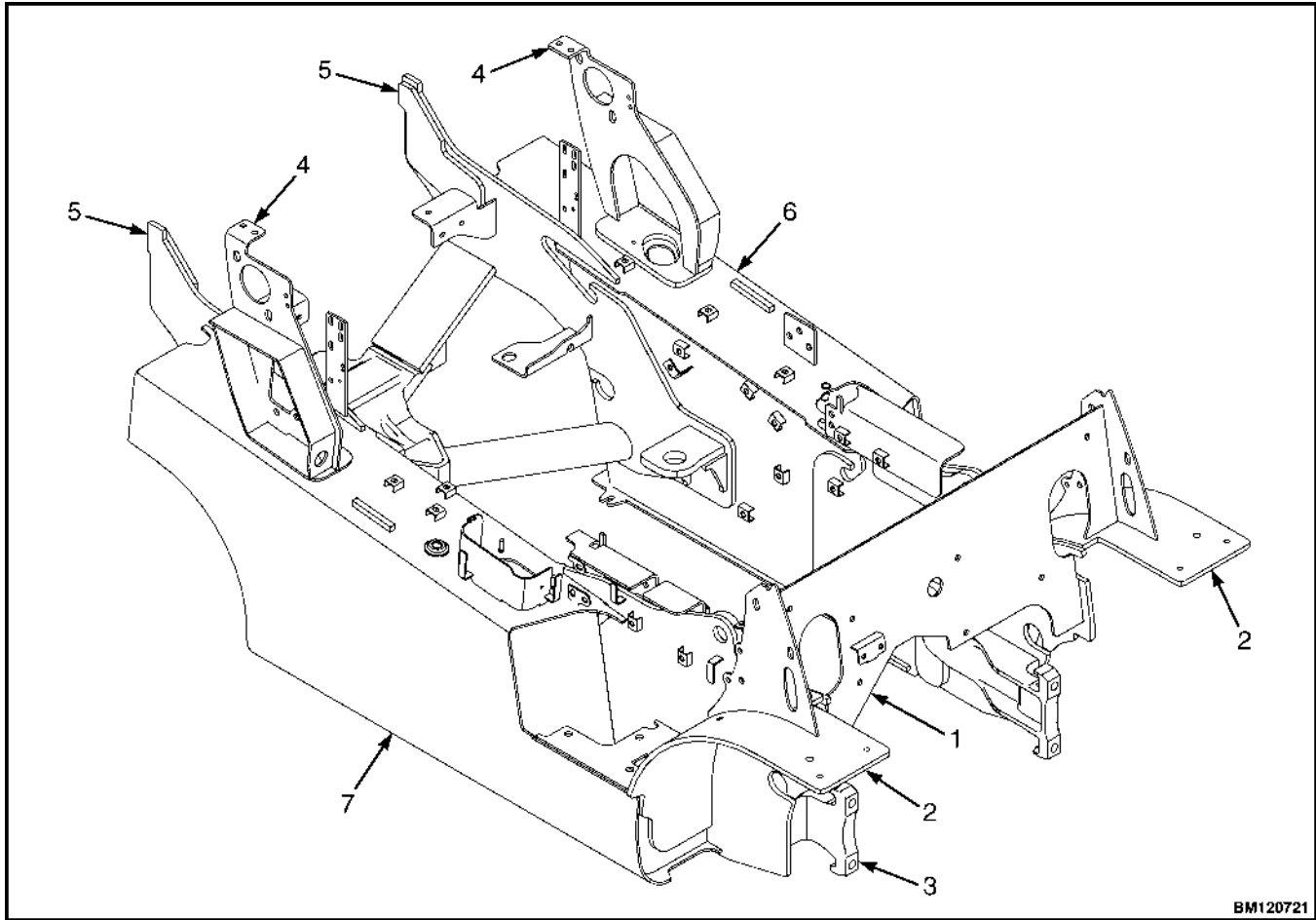

BM120721

- | | |
|---------------|--------------------------|
| 1. COWL PLATE | 5. COUNTERWIEGHT SUPPORT |
| 2. FENDER | 6. FUEL TANK |
| 3. FRAME | 7. HYDRAULIC TANK |
| 4. HOOD MOUNT | |

Figure 2. Frame, Dual Fuel or Diesel

Hood, Seat, and Side Covers Replacement

REMOVE

1. Slide the seat to the closest position to the steering column.
2. Fully tilt the steering column forward.

NOTE: Perform Step 3 for lift trucks equipped with LPG.

3. Swing LPG tank off to side. See **Fuel System PSI 2.4L 0900YRM1757** for procedures.
4. Raise the hood latch on the left, front corner of the hood to unlatch and lift up the hood. See Figure 3.
5. Remove the floor mat and floor plate. See Figure 4.
6. Remove the two capscrews holding the left and right rear side covers to the frame. Remove the rear side covers from the frame. See Figure 4.

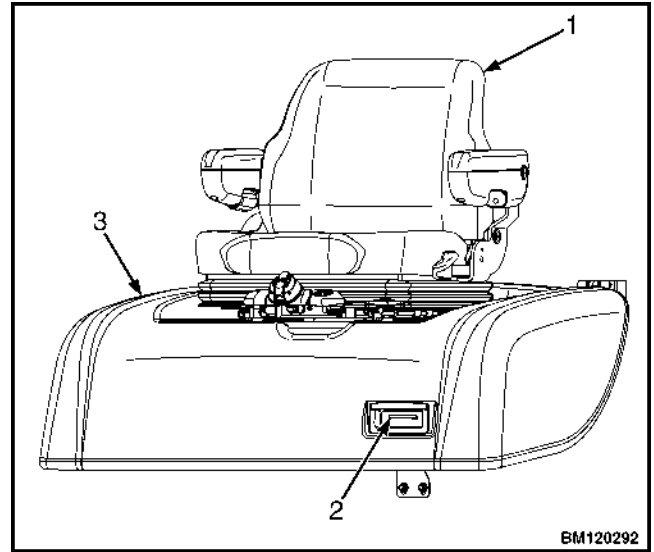

- | | |
|---------------|---------|
| 1. HOOD LATCH | 3. HOOD |
| 2. SEAT | |

Figure 3. Hood Latch

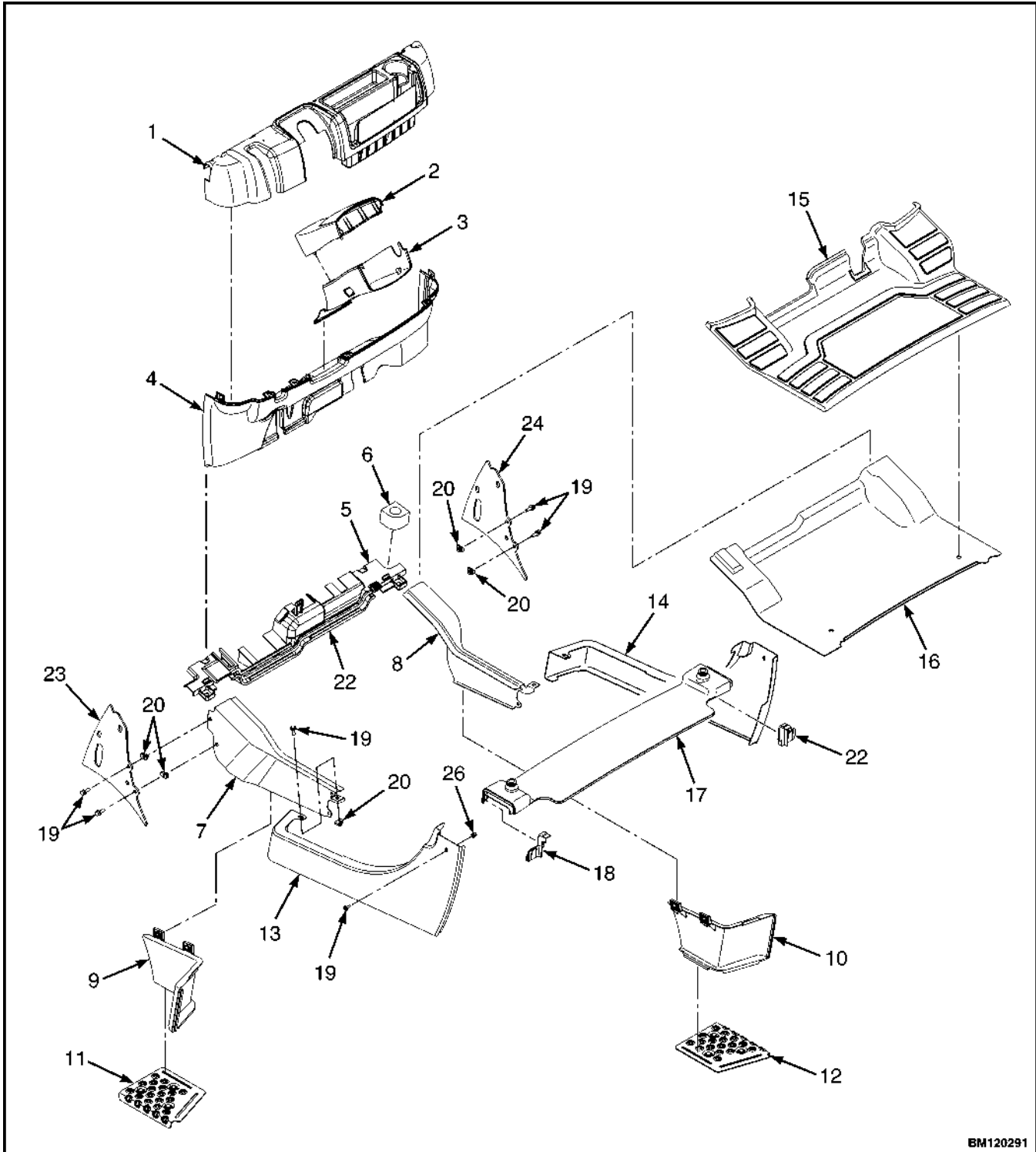

BM120291

Figure 4. Side Cover, Floor Plate, and Cowl Components

Legend for Figure 4

- | | |
|--------------------------------|---------------------------|
| 1. DASH ASSEMBLY | 13. LEFT REAR SIDE COVER |
| 2. UPPER STEERING COLUMN COVER | 14. RIGHT REAR SIDE COVER |
| 3. LOWER STEERING COLUMN COVER | 15. FLOOR MAT |
| 4. KICK PANEL | 16. FLOOR PLATE |
| 5. PLATE ASSEMBLY | 17. RADIATOR COVER |
| 6. GROMMET | 18. SEALS |
| 7. LEFT FRONT SIDE COVER | 19. CAPSCREW |
| 8. RIGHT FRONT SIDE COVER | 20. CLIP NUT |
| 9. LEFT STEP PANEL | 21. INSERT |
| 10. RIGHT STEP PANEL | 22. PLATE ASSEMBLY SEAL |
| 11. LEFT STEP PLATE | 23. LEFT COWL PLATE |
| 12. RIGHT STEP PLATE | 24. RIGHT COWL PLATE |

7. Remove the four capscrews and clip nuts holding the left and right front side covers and left and right cowl plates to the frame. Remove front side covers and cowl plates.
8. Fully lower the steering column.
9. Remove upper steering column cover by pulling up on the base of the upper steering column cover to release the latches (one on either side), and pulling cover away from steering column. See Figure 5.
10. Remove the five Allen Head screws (see Figure 5) securing the dash to top of cowl.
11. Pull kick panel up from bottom and out to remove kick panel from seal plate and clips on dash panel.
12. Remove dash panel from cowl. See Figure 6.
13. Remove three capscrews holding the seal plate. Remove seal plate. See Figure 6.

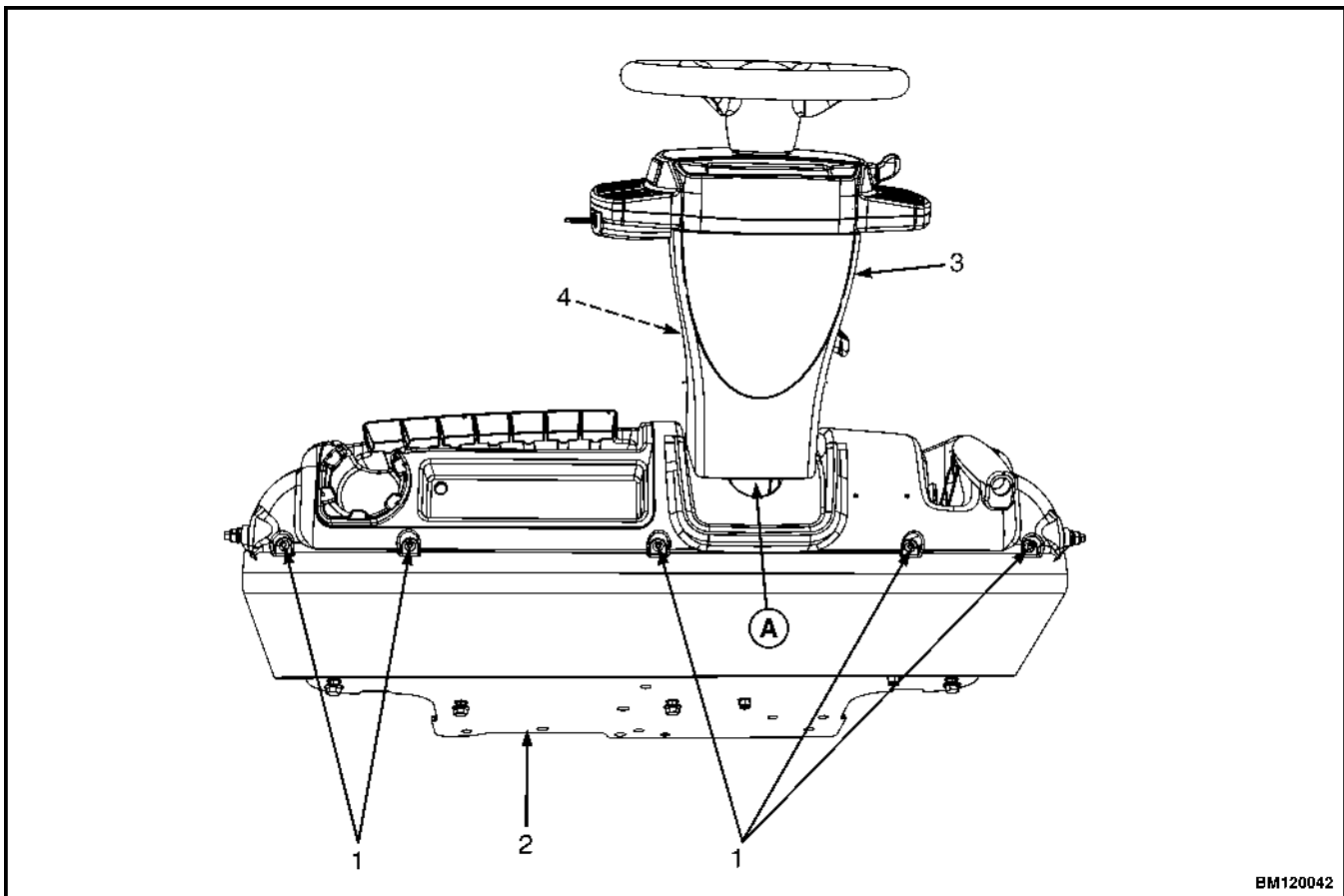

BM120042

NOTE: TOP VIEW OF DASH PANEL SHOWN

A. INDICATES TO PULL UP TO UNLATCH

- | | |
|----------------------|--------------------------------|
| 1. ALLEN HEAD SCREWS | 3. UPPER STEERING COLUMN COVER |
| 2. COWL | 4. LOWER STEERING COLUMN COVER |

Figure 5. Dash Panel and Upper Steering Column Cover Removal

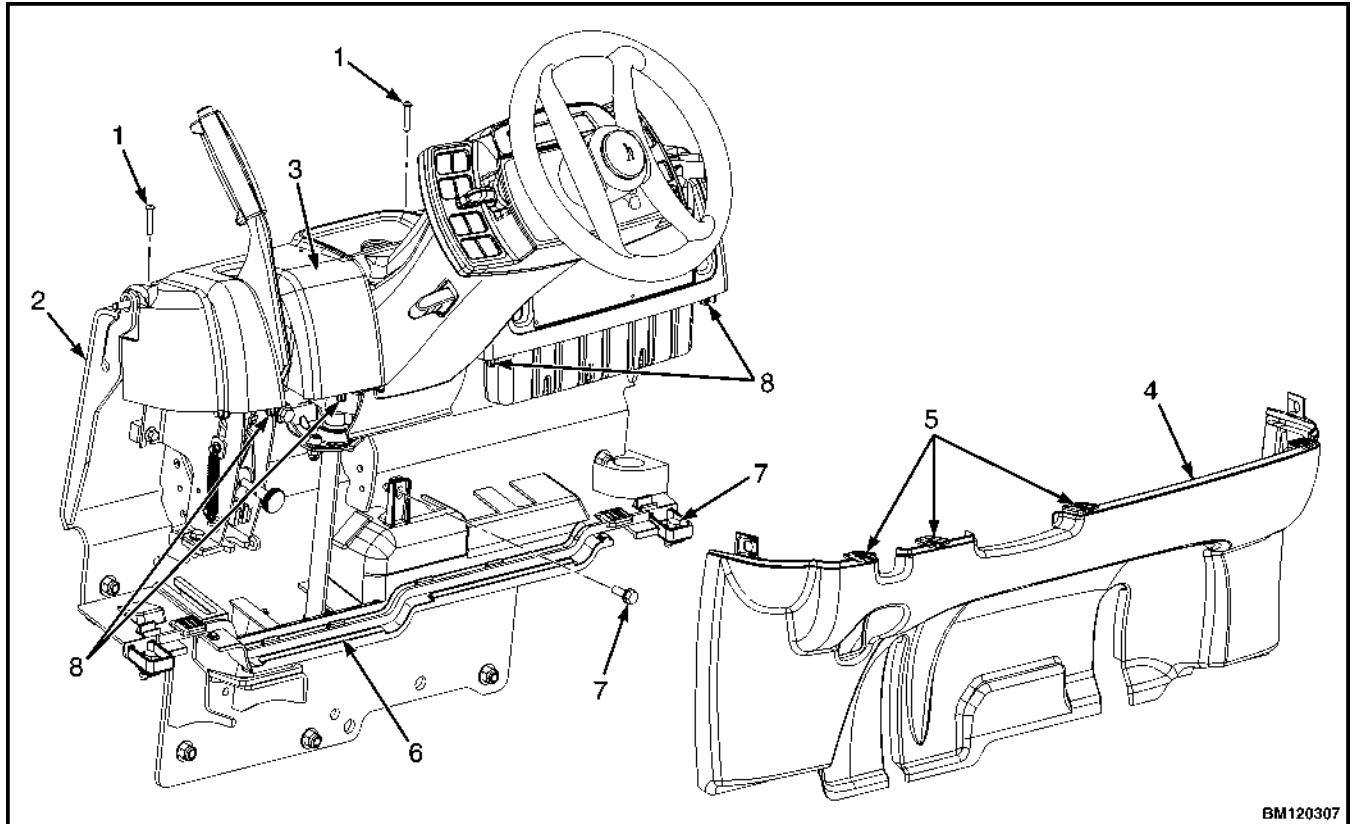

- | | |
|----------------------|-----------------------|
| 1. ALLEN HEAD SCREWS | 5. KICK PANEL NOTCHES |
| 2. COWL | 6. SEAL PLATE |
| 3. DASH PANEL | 7. CAPSCREWS |
| 4. KICK PANEL | 8. CLIPS |

Figure 6. Dash Panel, Kick Panel, and Seal Plate Removal

14. Remove two capscrews and washers from cover plate and remove electrical cover. Disconnect seat harness from chassis harness. See Figure 7.

CAUTION

When removing the seat from the hood, do not use an impact wrench to remove the capscrews. Damage can be caused to the threads on the capscrews and in the holes.

15. Open hood and pull chassis harness through hole in hood. See Figure 8.

Remove the four capscrews and nuts holding the seat to the hood. Lift the seat off the hood. See Figure 8. Close hood.

16. Remove the nuts from ball studs on gas springs. Remove gas springs from the hood. See Figure 9.
17. Remove the hinge capscrews and nuts, located in the rear of the hood. See Figure 9.
18. Lift the hood from the truck.

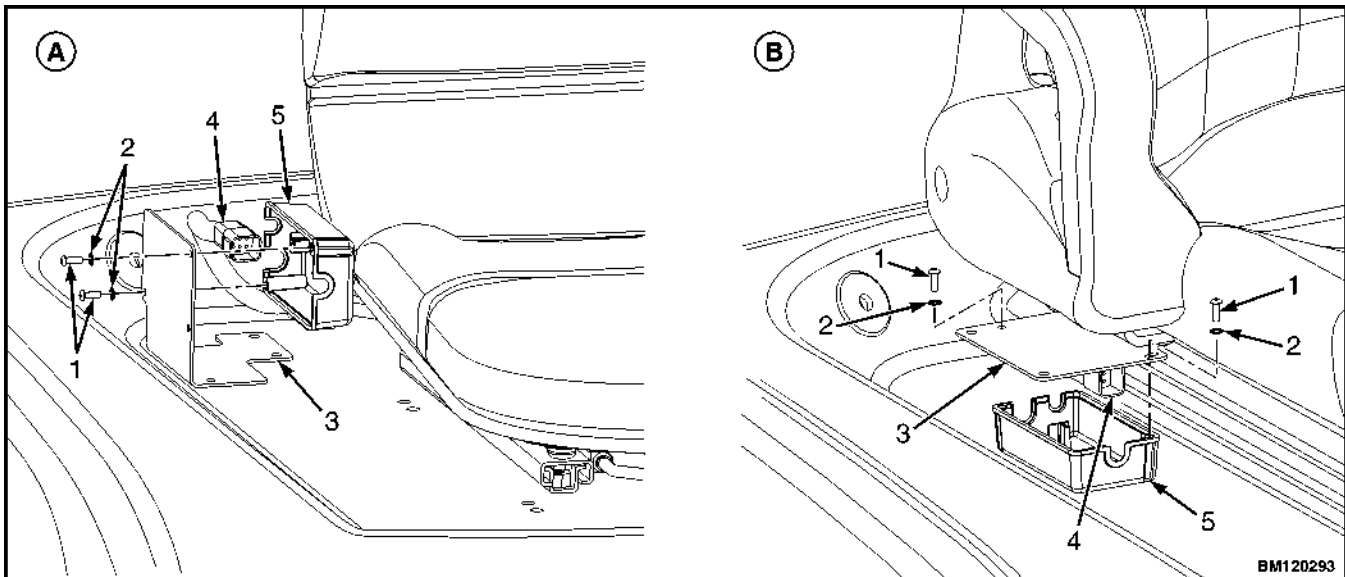

A. NON-SUSPENSION SEAT

1. CAPSCREWS
2. WASHER
3. COVER PLATE

B. FULL SUSPENSION SEAT

4. ELECTRICAL CONNECTOR (SEAT HARNESS)
5. ELECTRICAL COVER

Figure 7. Disconnect Seat Wire Harness

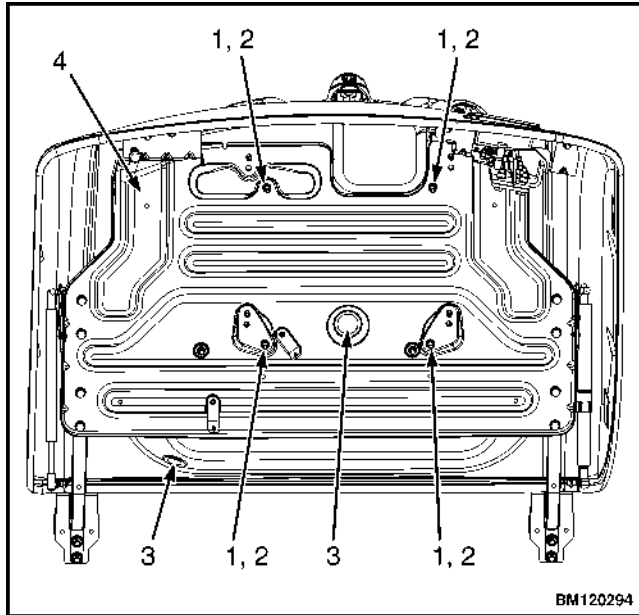
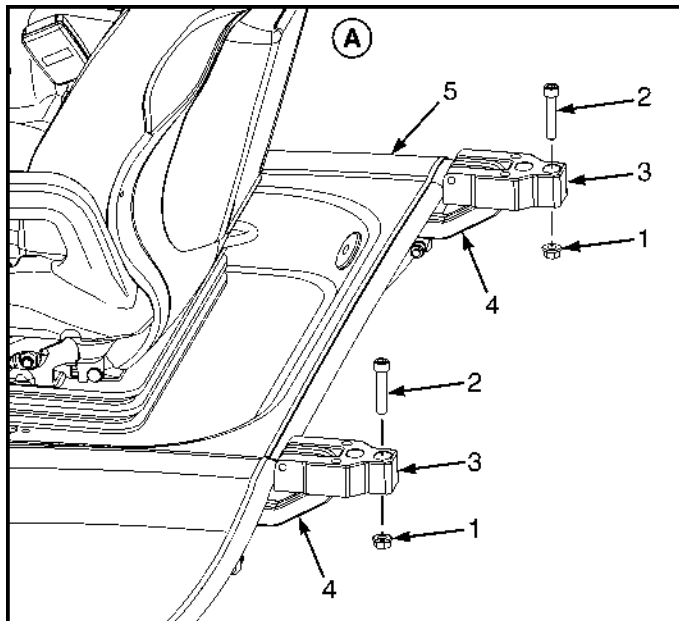

Figure 8. Remove Seat From Hood

Legend for Figure 8

NOTE: MOUNTING HOLES FOR FULL SUSPENSION SEAT SHOWN. MOUNTING HOLES FOR NON-SUSPENSION SEAT ARE THE SAME.

- 1. CAPSCREW
- 2. NUT
- 3. HOLE FOR CHASSIS HARNESS
- 4. HOOD LINER



A. HOOD HINGE ARRANGEMENT

- 1. NUT
- 2. CAPSCREW
- 3. HOOD HINGE MOUNT
- 4. HOOD HINGE ARM
- 5. HOOD

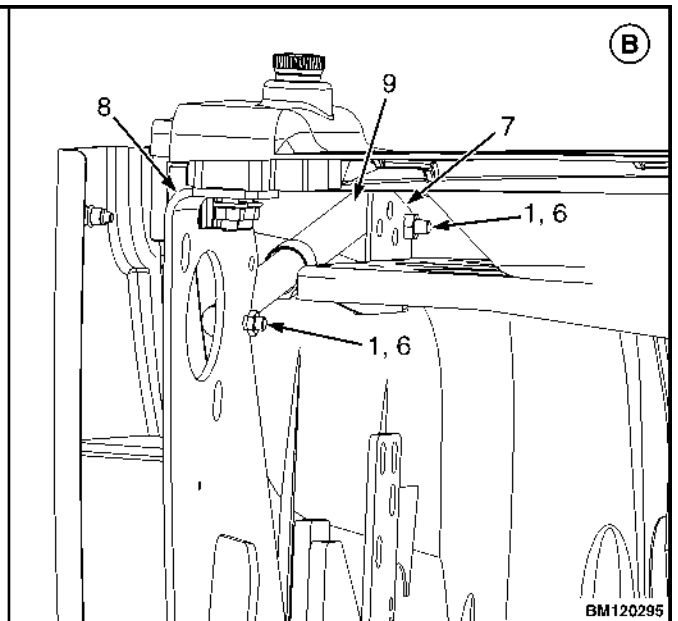

B. GAS SPRING ARRANGEMENT (LEFT SIDE SHOWN)

- 6. BALL STUD
- 7. GAS SPRING MOUNTING BRACKET
- 8. HOOD MOUNT
- 9. GAS SPRING

Figure 9. Gas Spring and Hood Removal

INSTALL

1. Place the hood onto the lift truck frame.
2. Install the hood hinge mount screws and nuts, located in the rear of the hood, and tighten to 38 N•m (28 lbf ft). See Figure 9.
3. Align the ball studs in the gas springs with holes in the gas spring mounting bracket and hood mount. See Figure 10 for holes to use depending on type of seat being installed. Install nuts on ball studs to attach gas springs to the hood. Tighten nuts to 19.2 N•m (170 lbf in).
4. Install latch striker in highest slot position. Check that latch striker is in center of jaws of hood latch when hood closes. Open and close the hood to

ensure that the center pin strikes the hood latch properly and that the stop screw contacts the frame. A properly closed hood MUST click twice on the hood latch. If the hood latch does not close properly, loosen the capscrews on the back of the center pin and adjust the center pin up or down as required for correct alignment. See Figure 11.

5. Push down until hood just touches rubber bumper. Make sure latch striker is still in center of hood latch. Open hood and tighten capscrews for latch.
6. Check operation of hood latch. Have an operator sit in the seat. Make sure hood is fully closed (two clicks). Also check that hood touches rubber bumper. If necessary, repeat Step 4 and Step 5.

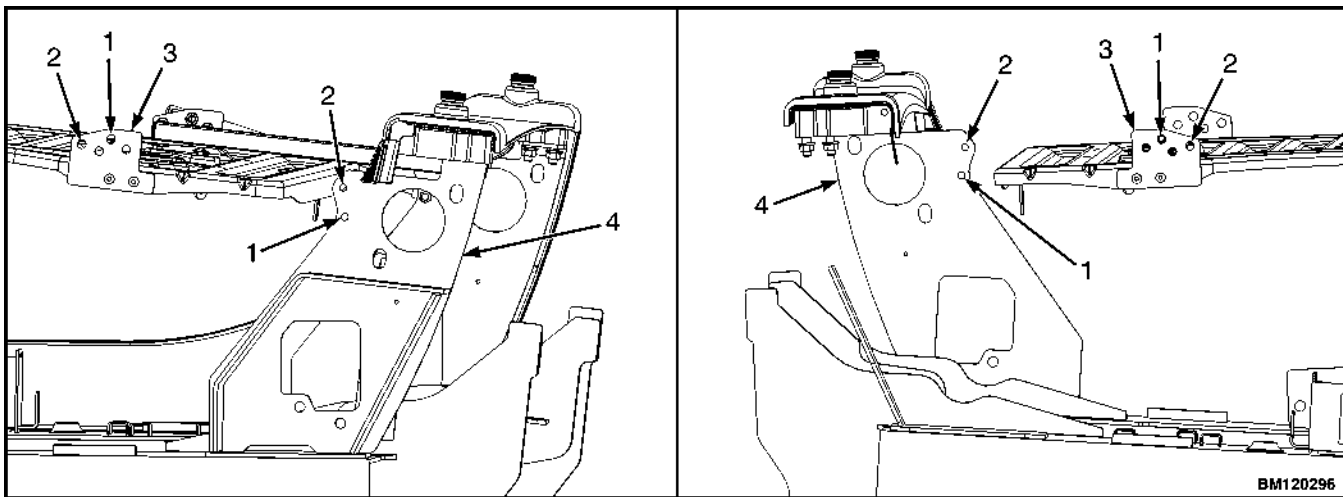

A. LEFT SIDE

1. FULL SUSPENSION SEAT
2. NON-SUSPENSION SEAT

B. RIGHT SIDE

3. GAS SPRING MOUNTING BRACKET
4. HOOD MOUNT

Figure 10. Gas Spring and Seat Hole Alignment

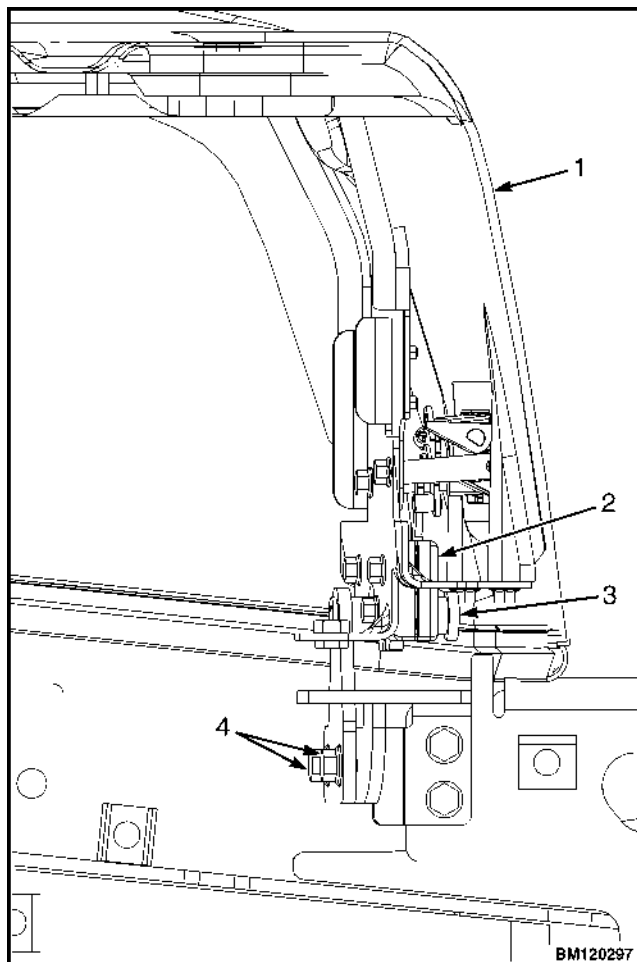

1. HOOD
2. HOOD LATCH
3. CENTER PIN
4. CAPSCREW

Figure 11. Hood Latch Adjustment



CAUTION

When installing the seat to the hood, do not use an impact wrench to install the capscrews. Damage can be caused to the threads on the screws and in the holes.

7. Place the seat on the hood and thread the chassis harness through the holes in the hood. See Figure 8.

8. Align the holes in the seat with the holes in the hood. See Figure 8. Insert capscrews and nuts. Tighten capscrews to 18 N•m (159 lbf in).
 9. Connect seat harness to chassis harness. Install cover plate to electrical cover using two capscrews and washers. See Figure 7.
 10. Using three capscrews, install seal plate. See Figure 6. Tighten capscrews to 10.8 N•m (95.6 lbf in).
 11. Place dash panel on cowl and secure dash panel to cowl using five Allen Head screws. Tighten Allen Head screws to 3.5 N•m (31 lbf in). See Figure 5.
 12. Align notches on kick panel to clips on dash panel and push kick panel into place on seal plate. See Figure 6.
 13. Raise steering column to highest position and install upper steering column cover by aligning the two latches and pushing down until latched. See Figure 5.
 14. Using four capscrews and clip nuts, install the left and right front side covers and left and right cowl plates to the frame. See Figure 4.
 15. Using two capscrews, install the left and right rear side covers to the frame. See Figure 4.
 16. Install the floor mat and floor plate.
- NOTE:** Perform Step 17 for lift trucks equipped with LPG.
17. Swing the LPG tank into position on back of counterweight. See **Fuel System PSI 2.4L** 0900YRM1757 for procedures.
 18. Adjust the steering column and seat positions.

Steering Column

DESCRIPTION

This section describes the repair procedures for the steering column. The Steering Column Assembly mounts to the cowl inside the operator compartment and is the mechanical connection between the steering wheel and the steering control unit. The steering column includes the steering wheel, housing, bracket and lower shaft. For lift trucks with gas and LPG engines, bolts and bushings attach the steering column to the cowl standoffs. For lift trucks with diesel engines, bolts, bushings and isolators attach the steering column to the cowl standoffs See Figure 12.

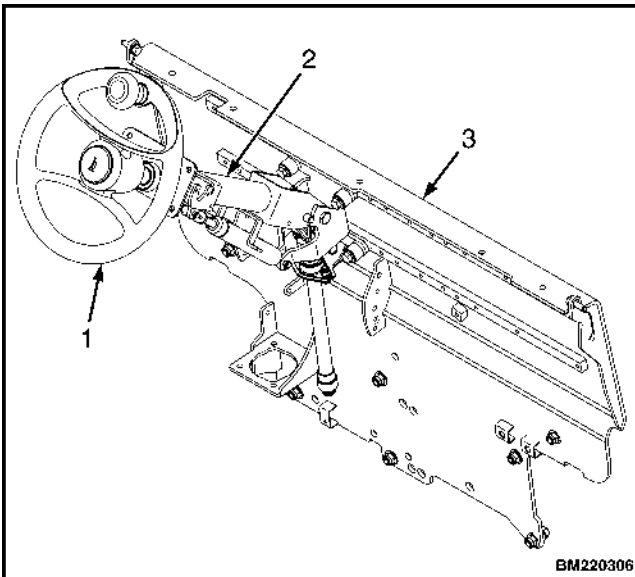

NOTE: DIESEL SHOWN, LPG AND BI-FUEL SIMILAR.

1. STEERING WHEEL
2. STEERING COLUMN
3. COWL

Figure 12. Steering Column and Cowl

STEERING COLUMN REPAIR

Remove

1. Put blocks on each side (front and back) of tires to prevent lift truck from moving.

CAUTION

Disconnect the negative battery cable on internal combustion trucks. Disconnect the battery before removing any covers.

2. Attach a tag on the battery connector or negative battery cable stating, DO NOT CONNECT BATTERY. Move the steering column to the most FORWARD position.

CAUTION

If a puller tool is used to remove steering wheel from steering column, be careful not to damage horn wires.

NOTE: This procedure is for the removal of all components of the steering column assembly. All components are not often removed for a repair procedure. Do only those steps of the procedure necessary to remove the required component.

NOTE: Tag wires prior to disconnect

3. Remove the horn button assembly and disconnect electrical wires. Remove large hex nut and steering wheel from steering column. See Figure 13.

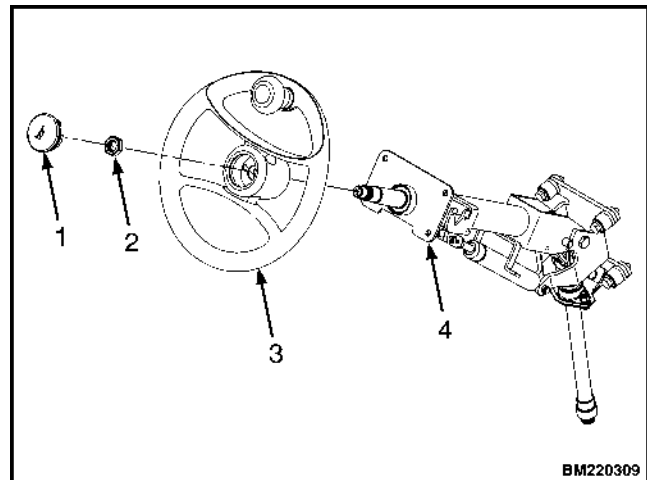

1. HORN BUTTON
2. HEX NUT
3. STEERING WHEEL
4. STEERING COLUMN

Figure 13. Steering Wheel Remove/Install

4. Remove steering column covers. Remove floor mats and floor plate. See section Hood, Seat, and Side Covers Replacement.

NOTE: Perform Step 5 for lift trucks equipped with bi-fuel or LPG engines.

5. Remove four capscrews, four bushings and steering column from cowl standoffs. See Figure 14.

NOTE: Perform Step 6 for lift trucks equipped with diesel engines.

6. Remove four capscrews, four bushings, four isolators, steering column and four isolators from cowl standoffs. See Figure 14.

Disassemble

NOTE: Remove and discard snap rings if installed.

1. Remove two pins and gas spring from housing. See Figure 15.
2. Remove two pivot bolts, two bushings, two nuts and bracket from housing.
3. Remove split pin and lower shaft from upper shaft.
4. Remove connector from connector bracket. Remove connector bracket, fastener, four screws and two horn contacts from housing.

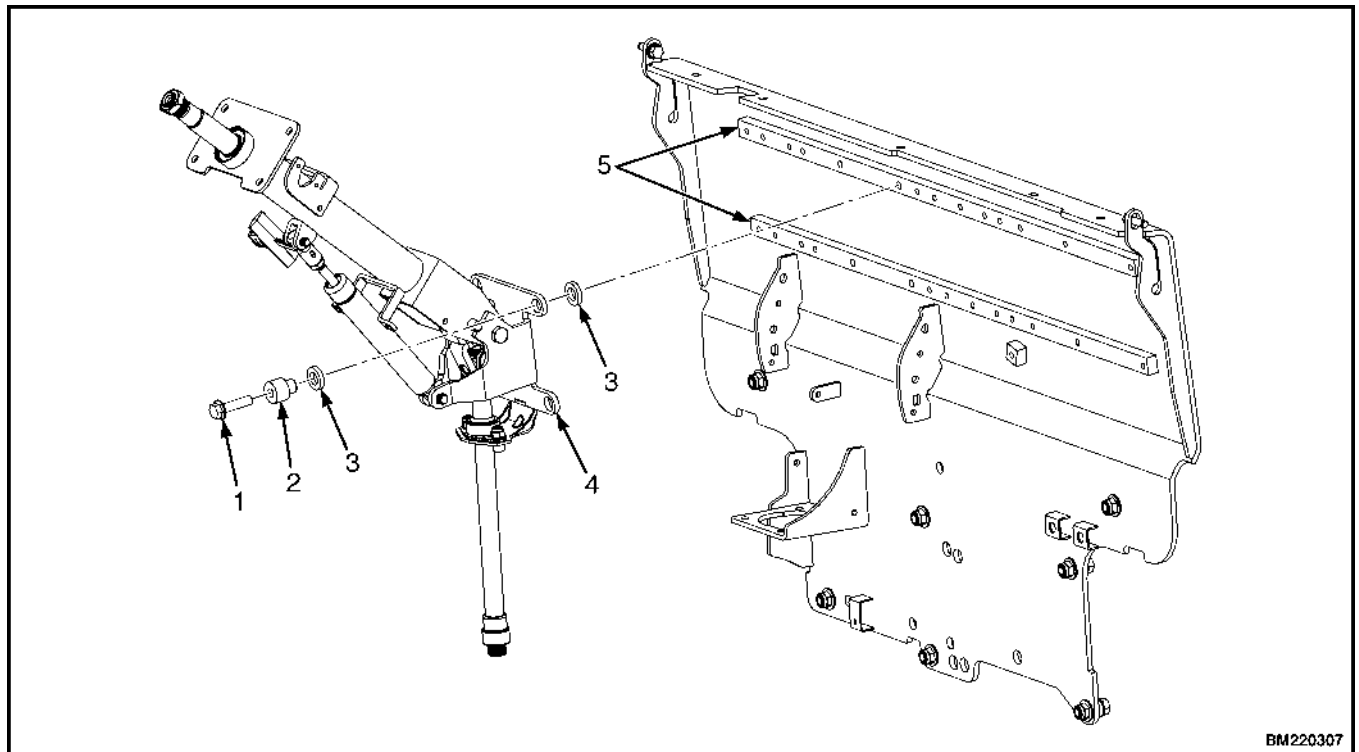

NOTE: DIESEL SHOWN, LPG AND GAS SIMILAR.

- | | |
|-------------|--------------------|
| 1. CAPSCREW | 4. STEERING COLUMN |
| 2. BUSHING | 5. COWL STANDOFF |
| 3. ISOLATOR | |

Figure 14. Steering Column Remove/Install

Clean**WARNING**

Cleaning solvents can be flammable and toxic and can cause skin irritation. When using cleaning solvents, always follow the solvent manufacturer's recommended safety precautions.

**WARNING**

Compressed air is used for cleaning and drying purposes, or for cleaning restrictions. wear protective clothing (goggles/shields, gloves, etc.). Make sure the path of the compressed air is away from all personnel to avoid injury.

1. Clean metal parts in solvent. Remove all traces of old lubricant and dirt. Clean nonmetal parts with warm soapy water and a lint free cloth.
2. After cleaning dry parts with compressed air. DO NOT dry parts with a cloth.

Inspect

1. Inspect for loose, burned, missing, cracked or damaged hardware.
2. Inspect all parts for dents, holes, bends, burrs, rust, corrosion or marred finishes.
3. Replace all defective or damaged parts.

Assemble

NOTE: This procedure is for the installation of all components of the steering column assembly. All components are not often removed for a repair procedure. Do only those steps of the procedure necessary to install the required component.

NOTE: Perform Step 1 only for lift trucks manufactured before January, 2012.

1. Lubricate the horn contact slip rings with a small amount of conductive grease Yale P/N 582014302. See Figure 15.

2. Install fastener, connector bracket and connector, two horn contacts and four screws.
3. Assemble lower shaft and upper shaft, secure with spit pin.
4. Install two pivot bolts, two bushings, two nuts and bracket onto housing.
5. Install gas spring and two pins on housing.

Install

NOTE: Lubricate spline end of lower shaft with multi purpose grease, see **Periodic Maintenance Manual** for your lift truck.

NOTE: Perform Step 1 for lift trucks equipped with gas or LPG engines.

1. Install steering column, four bushings and four bolts on cowl standoffs. Tighten bolts to 38 N•m (28 lbf ft). See Figure 14.

NOTE: Perform Step 2 for lift trucks equipped with diesel engines.

2. Install four isolators, steering column four isolators, four bushings and four bolts standoffs on cowl. Tighten bolts to 38 N•m (28 lbf ft). See Figure 14.
3. Install floor plate, floor mats and steering column covers. See section Hood, Seat, and Side Covers Replacement.
4. Install steering wheel and hex nut on steering column. Tighten hex nut to 40 to 54 N•m (30 to 40 lbf ft). Connect electrical wiring and install horn button. See Figure 13.
5. Remove tag from negative battery connector and connect to battery. Adjust steering column to neutral position.
6. Remove blocks from each side of tires.

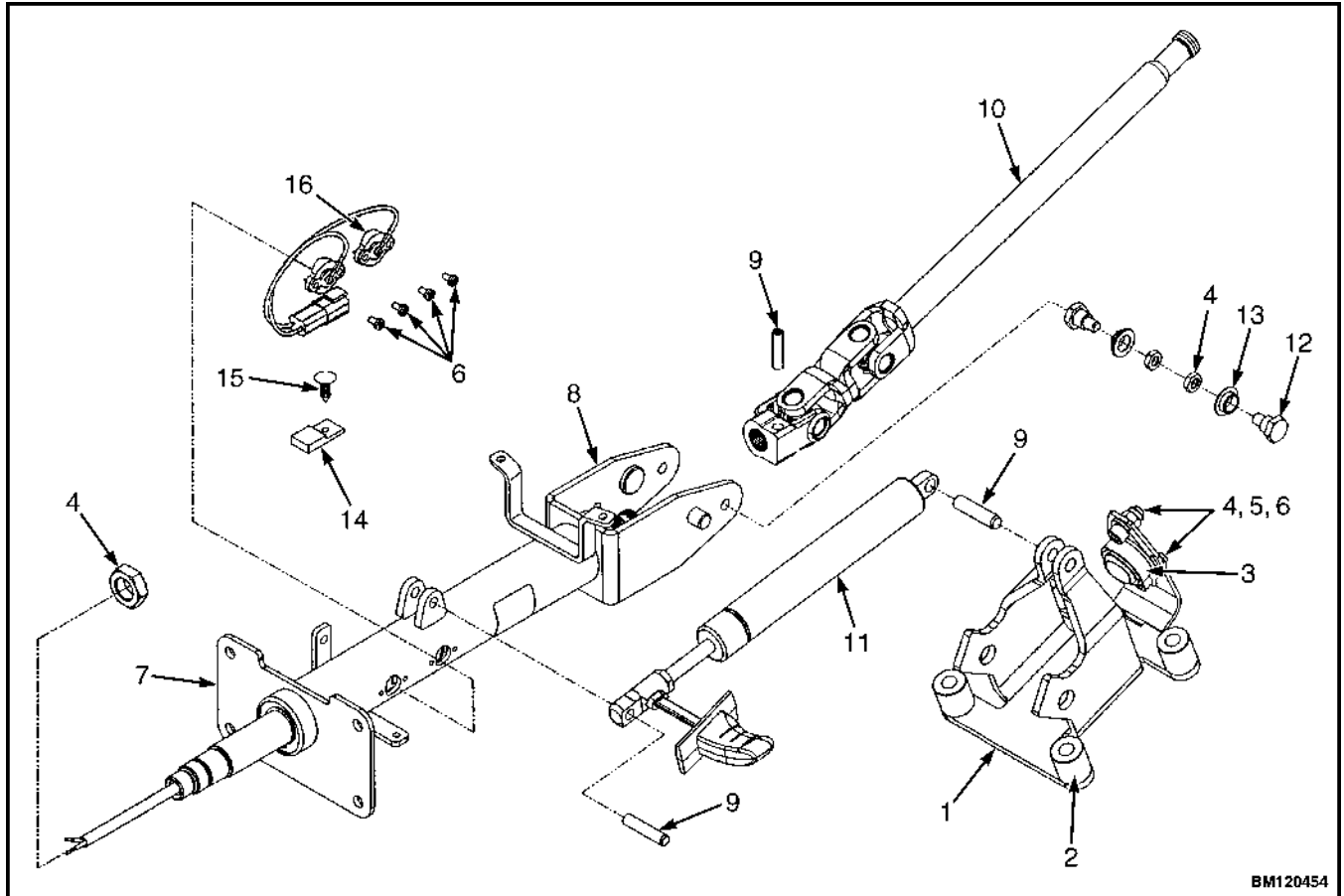

BM120454

- | | |
|----------------|------------------|
| 1. BRACKET | 9. PIN |
| 2. SPACER | 10. LOWER SHAFT |
| 3. JOINT | 11. GAS SPRING |
| 4. NUT | 12. BOLT |
| 5. WASHER | 13. BUSHING |
| 6. SCREW | 14. CONNECTOR |
| 7. UPPER SHAFT | 15. FASTENER |
| 8. HOUSING | 16. HORN CONTACT |

Figure 15. Steering Column Assembly

Counterweight Replacement

REMOVE



WARNING

The lift truck must be put on blocks for some types of maintenance and repair. The removal of the following assemblies will cause large changes in the center of gravity: mast, drive axle, engine and transmission, and counterweight. When the lift truck is put on blocks, put additional blocks in the following positions to maintain stability:

- Before removing the mast and drive axle, put blocks under the counterweight so the lift truck cannot fall backward.
- Before removing the counterweight, put blocks under the mast assembly so the lift truck cannot fall forward.

The surface must be solid, even, and level when the lift truck is put on blocks. Make sure that any blocks used to support the lift truck are solid, one-piece units. See the Operating Manual or Periodic Maintenance 8000YRM1774.



WARNING

DO NOT operate the lift truck if the capscrew for the counterweight is not installed. When the capscrew is removed, the counterweight can fall from the lift truck.



WARNING

LPG can cause an explosion. DO NOT cause sparks or permit flammable material near the LPG system. LPG fuel systems can be disconnected indoors only if the lift truck is at least 8 m (26 ft) from any open flame, motor vehicles, electrical equipment, or ignition source.

Close the shutoff valve on the LPG tank before any part of the engine fuel system is disconnected. Run the engine until the fuel in the system is used and the engine stops.

If the engine will not run, close the shutoff valve on the LPG tank. Loosen the fitting on the supply hose from the LPG tank where it enters the filter unit. Permit the pressure in the fuel system to decrease slowly. Fuel leaving the fitting removes heat. Use a cloth to protect your hands from the cold fitting.

NOTE: The counterweight is held in position on the frame by two hooks that are part of the frame. One M24 × 3 × 110 capscrew holds the counterweight to the lower part of the frame on lift truck models See Figure 16.

NOTE: Perform Step 1 for lift trucks equipped with LPG.

1. Use the procedures in **Fuel System PSI 2.4L** 0900YRM1757 to remove the LPG tank and bracket so that the counterweight can be removed.

Additional information on the LPG fuel system can be found in **Fuel System PSI 2.4L** 0900YRM1757.



WARNING

The counterweight is heavy. Make sure that the eyebolts and lifting devices have enough capacity to lift the weight. The approximate weights of the counterweight castings are shown in Table 1.

2. Install washers, lifting eyebolts, and nuts into lift holes of the counterweight. See Figure 17. Connect a crane to the lifting eyebolts and raise the crane until it holds part of the weight of the counterweight.
3. Remove the tow pin from counterweight.
4. Remove the capscrew from counterweight and frame. See Figure 16 and Figure 17. Use the crane to lift the counterweight from the lift truck. Put counterweight on the floor so that it has stability and will not fall over. Take care not to damage exhaust or cooling system components.

Table 1. Weight of Counterweights

Model	kg	lb
GLC050LX (B967)	1401	3088
GLP/GDP20LX (B974)	950	2094
GLP/GDP25LX (GLP/GDP050LX) (B974)	1230	2712
GLP/GDP25LX (GLP/GDP050LX) (B974)	1335	2943

INSTALL

1. Make sure the seals are on the counterweight. If lifting eyebolts were removed from counterweight, install washers, lifting eyebolts, and nuts into lift holes on counterweight. See Figure 17.
2. Connect a crane to the lifting eyebolts and place counterweight in position on lift truck frame. Make sure hooks on frame fully engage counterweight so it is aligned with the frame.
3. Install capscrew onto counterweight and frame. See Figure 16 and Figure 17. Tighten capscrew to 555 N•m (409 lbf ft).

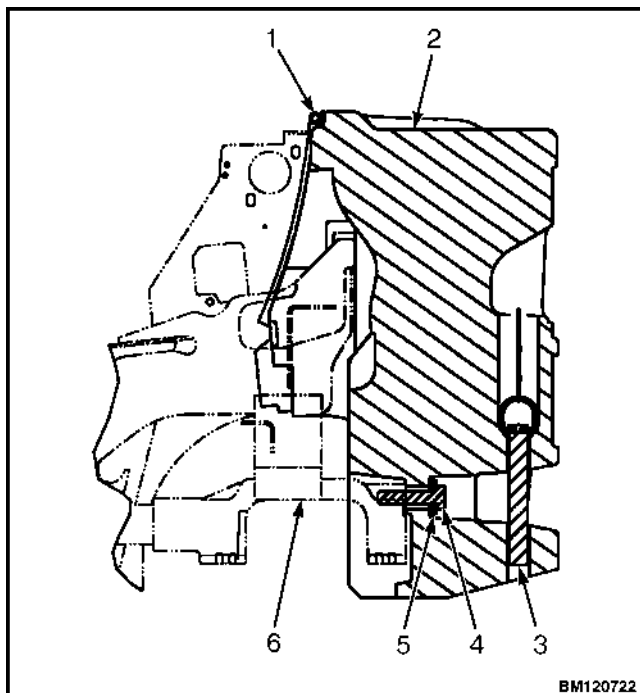

1. SEAL
2. COUNTERWEIGHT
3. TOW PIN
4. CAPSCREW
5. WASHER
6. FRAME

Figure 16. Counterweight Installation

4. Install tow pin onto counterweight.

NOTE: Perform Step 5 for lift trucks equipped with LPG.

5. Use the procedures in **Fuel System PSI 2.4L 0900YRM1757** to install the LPG tank and bracket after the counterweight has been installed.

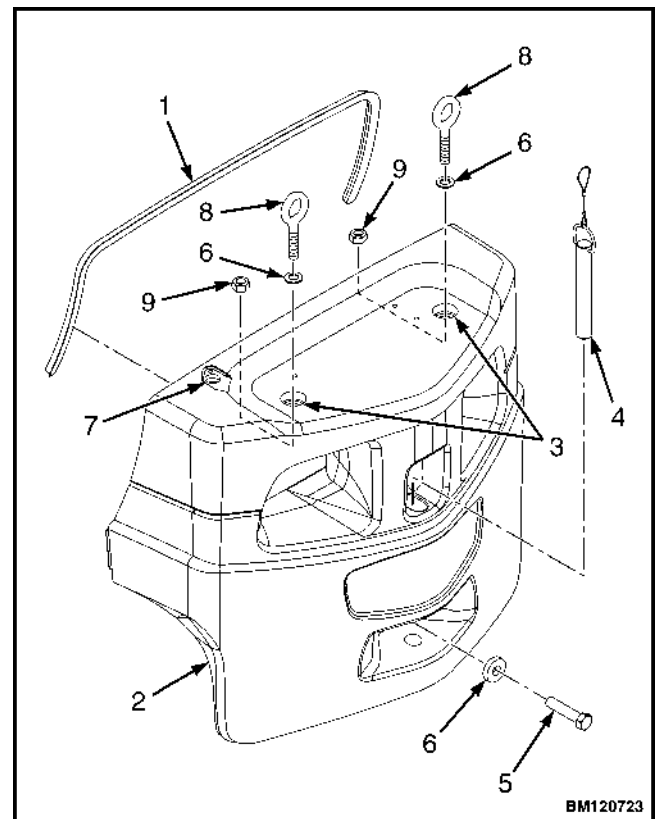

1. SEAL
2. COUNTERWEIGHT
3. LIFT HOLE
4. TOW PIN
5. CAPSCREW
6. WASHER
7. LPG ACCESS HOLE
8. LIFTING EYEBOLT
9. NUT

Figure 17. Counterweight With Lifting Eyebolts

Overhead Guard Replacement

REMOVE



WARNING

DO NOT operate the lift truck without the overhead guard correctly fastened to the lift truck.



WARNING

DO NOT weld mounts for lights or accessories to legs of the overhead guard. Changes that are made by welding, or by drilling holes that are too big or in the wrong location, can reduce the strength of the overhead guard.

See your dealer for Yale lift trucks **BEFORE** performing any changes to the overhead guard.

NOTE: The lifting device can be connected to any number of positions on the overhead guard depending upon the lifting device available. The ideal choices are a four point sling connected to all four corners on the top of the overhead guard, or a two point sling connected to two opposite corners of the overhead guard. If a single point hoist is used, make sure that the lift point is as close to the center of the overhead guard as possible. If during the initial start of the lift, the overhead guard is off balance, lower immediately and move the hoist to a more centered point.

No welding or drilling on legs of overhead guard is permitted as per previous **WARNING**.

1. Connect a lifting device to overhead guard.

NOTE: Note routing of electrical wires prior to disconnecting. Tag electrical connectors during removal to aid in installation.

2. Disconnect wires between frame and overhead guard.
3. Remove capscrews from overhead guard rear legs and frame. See Figure 18.
4. Remove dash and kick panel from cowl. See section Hood, Seat, and Side Covers Replacement for removal procedures.

5. Remove capscrews from overhead guard front legs and frame. See Figure 18.

NOTE: When overhead guard is lifted from the frame, make sure that any electrical wires are moved through the holes in the frame so that they are not damaged.

6. Using lifting device, remove overhead guard from frame. See Figure 18.
7. Remove capscrews and handle from overhead guard. See Figure 18.

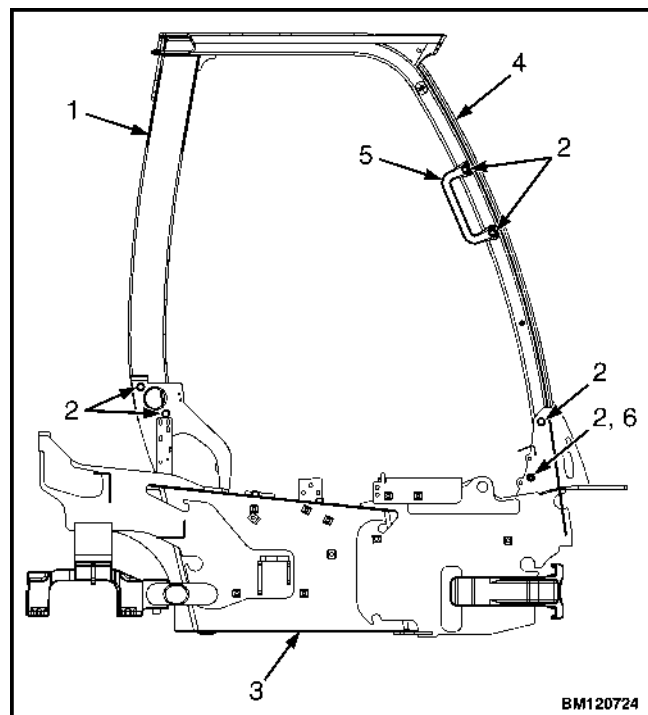

1. OVERHEAD GUARD REAR LEG
2. CAPSCREW
3. FRAME
4. OVERHEAD GUARD FRONT LEG
5. HANDLE
6. NUT

Figure 18. Overhead Guard

INSTALL

NOTE: Make sure electrical wires are routed as noted during removal to ensure that wires do not get pinched.

1. Using lifting device, install overhead guard onto frame.
2. Install capscrews onto overhead guard front legs and frame. See Figure 18. Tighten capscrews to 66 N•m (49 lbf ft).
3. Install kick panel and dash onto cowl. See section Hood, Seat, and Side Covers Replacement for install procedures.
4. Install capscrews onto overhead guard rear legs and frame. See Figure 18. Tighten capscrews to 66 N•m (49 lbf ft).
5. Connect electrical wires as tagged during removal.
6. Install handle and capscrews onto overhead guard. See Figure 18.

Rain Top (Optional)

Remove

1. Remove two capscrews, two locknuts, two bushings and two washers from bracket and rain top at front center of overhead guard. See Figure 19.
2. Remove two capscrews, two locknuts, two bushings and two washers from bracket and rain top at front corners of overhead guard. See Figure 19.
3. Remove two capscrews, two wheel nuts and two brackets from front center of overhead guard. See Figure 19.
4. Remove two capscrews, two wheel nuts, right bracket and left bracket from front corner of overhead guard. See Figure 19.

NOTE: Note position of rain top on overhead guard before removal.

5. Remove rain top from overhead guard. See Figure 19.

Clean and Inspect

1. Clean all remaining sealer residue from rain top and overhead guard surfaces.
2. Inspect rain top and brackets for cracks. Replace if necessary.

Install

1. Apply a continuous bead of sealer to back corners of overhead guard. See (item 10) Figure 19.

NOTE: Apply even pressure to rain top to squeeze down sealer to a thickness of 3 to 5 mm (0.118 to 0.197 in.).

2. Install rain top onto overhead guard as noted during removal.
3. Install right bracket, left bracket two capscrews, two wheel nuts, onto front corner of overhead guard. See Figure 19.
4. Install two brackets, two capscrews, and two wheel nuts to front center of overhead guard. See Figure 19.
5. Install two capscrews, two bushings, two washers and two locknuts onto bracket and rain top at front corners of overhead guard. See Figure 19.
6. Install two capscrews, two bushings, two washers and two locknuts onto bracket and rain top at front center of overhead guard. See Figure 19.

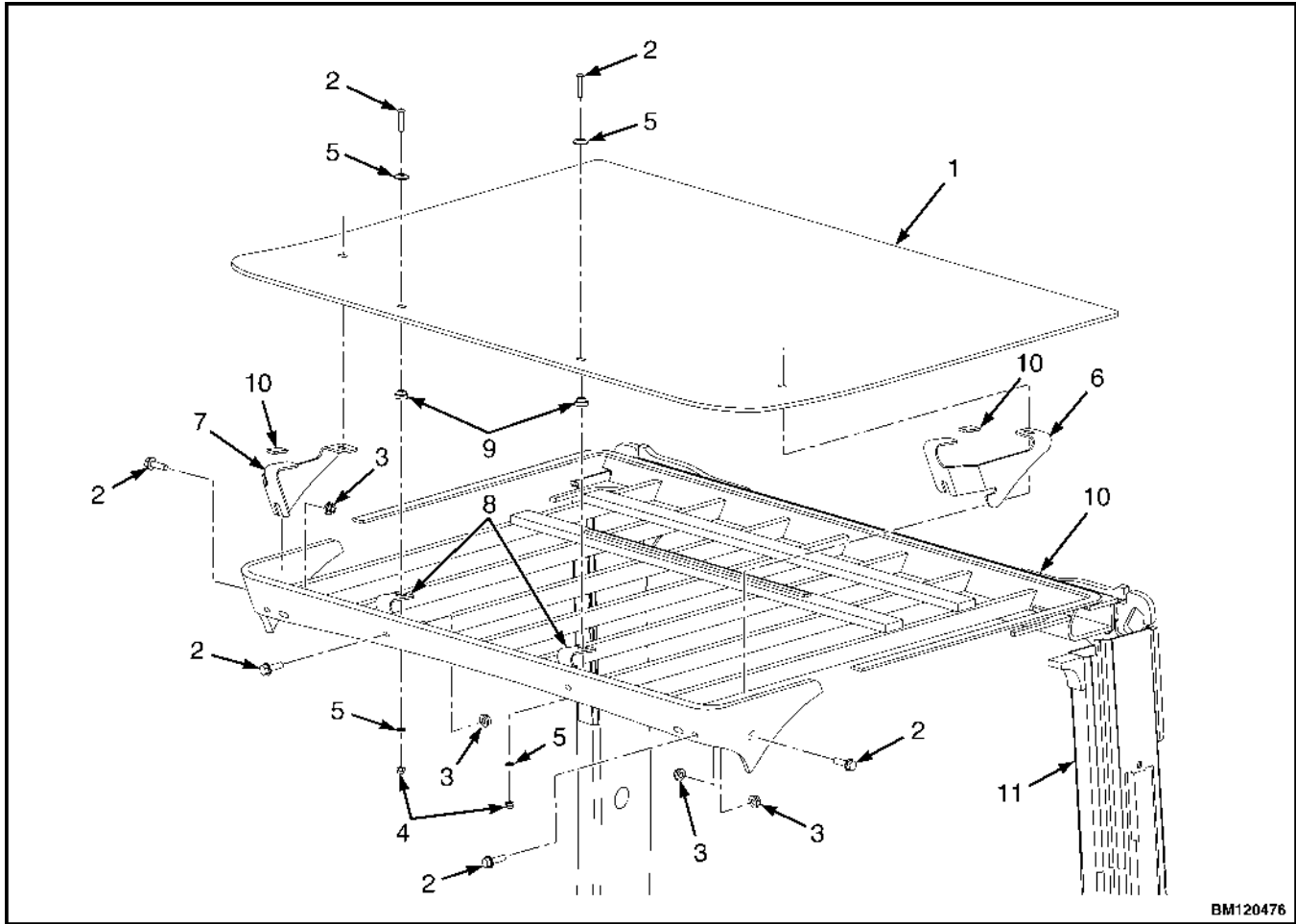

BM120476

- | | |
|-----------------|--------------------|
| 1. RAIN TOP | 7. RIGHT BRACKET |
| 2. CAPSCREW | 8. CENTER BRACKET |
| 3. WHEEL NUT | 9. BUSHING |
| 4. LOCKNUT | 10. SEALER |
| 5. WASHER | 11. OVERHEAD GUARD |
| 6. LEFT BRACKET | |

Figure 19. Overhead Guard Rain Top

Operator Restraint System Replacement

DESCRIPTION

The seat belt, hip restraint brackets, seat and mounting, hood, and latches are all part of the operator restraint system. Each item must be checked to make sure it is attached securely, functions correctly, and is in good condition. See Figure 20.

Emergency Locking Retractor (ELR)

When the ELR style seat belt is properly buckled across the operator, the belt will permit slight operator repositioning without activating the locking mechanism. If the truck tips over, travels off a dock, or comes to a sudden stop, the locking mechanism will be activated and hold the operator's lower torso in the seat.

A seat belt that is damaged worn or does not operate properly will not provide protection when it is needed. The end of the belt must fasten correctly in the latch. The seat belt must be in good condition. Replace the seat belt if it is damaged or worn. See Figure 20.

NOTE: The following seat belt operation checks must be performed three times before replacing the seat belt assembly:

- With the hood closed and in the locked position, pull the seat belt slowly from the retractor assembly. Make sure the seat belt pulls out and retracts smoothly. If the seat belt does not pull out of the retractor assembly, the internal latch may be locked.

Pull firmly on the seat belt and hold for a moment to remove slack from the belt in the retractor. Release the seat belt. Seat belt will retract and the internal latch will unlock. If the seat belt cannot be pulled from the retractor assembly or the belt will not retract, replace the seat belt assembly.

- With the hood closed and in the locked position, pull the seat belt with a sudden jerk. Make sure the seat belt will not pull from the retractor assembly. If the seat belt can be pulled from the retractor, when it is pulled with a sudden jerk, replace the seat belt assembly.
- With the hood in the open position, make sure the seat belt will not pull from the retractor assembly. If the seat belt can be pulled from the retractor, with the hood in the open position, replace the seat belt assembly.

Make sure the seat rails and hood latch are not loose. The seat rails must lock securely in position but move freely when unlocked. The seat rails must be securely attached to the mounting surface. The hood must be fully closed. Lift the hood to make sure it is closed and will not move.

Adjust hood and hood latch when any of the parts of the operator restraint system are installed or replaced. See section Hood, Seat, and Side Covers Replacement in this manual for the adjustment procedures for the hood.

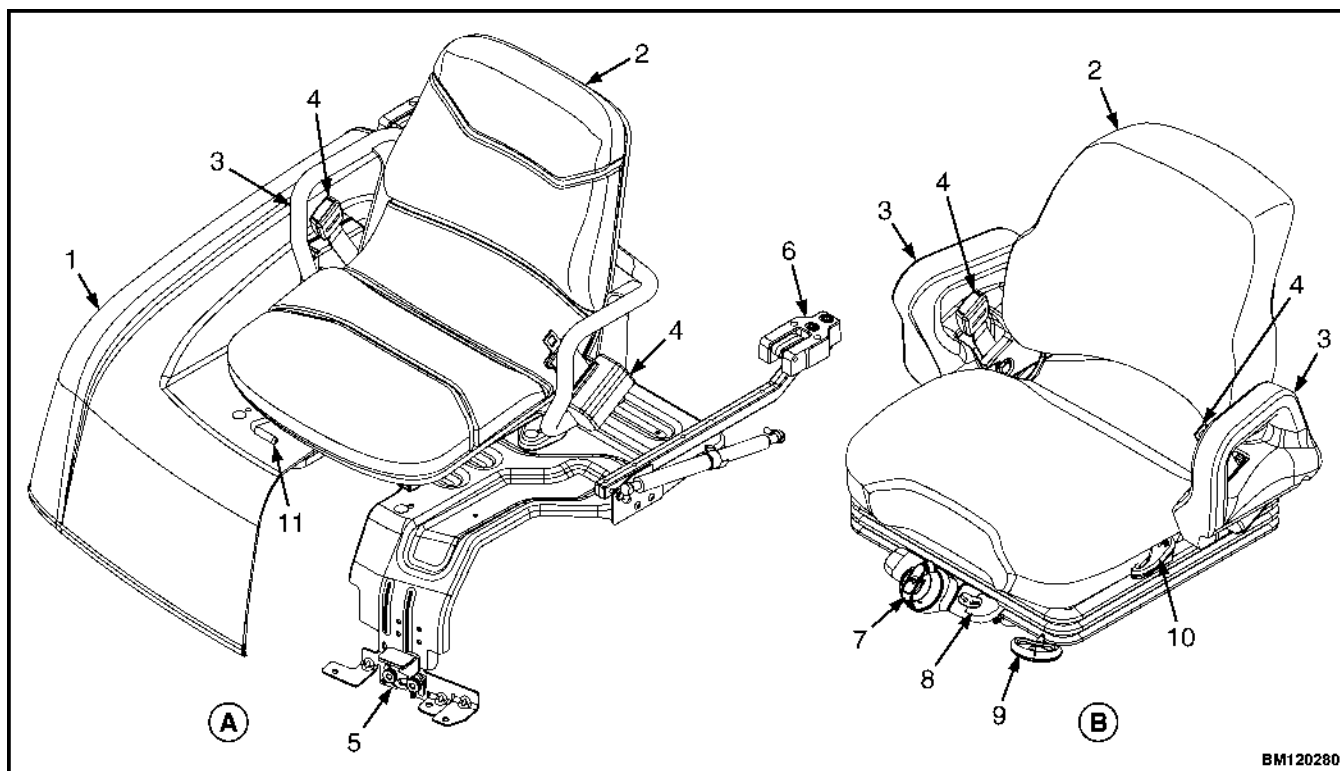
**A. NON-SUSPENSION SEAT**

1. HOOD
2. SEAT
3. HIP RESTRAINT
4. SEAT BELT
5. LATCH
6. HOOD HINGE

B. FULL-SUSPENSION SEAT

7. WEIGHT ADJUSTMENT KNOW
8. RIDE POSITION INDICATOR
9. FORWARD/BACKWARD ADJUSTMENT LEVER
10. BACKREST ADJUSTMENT LEVER
11. SEAT RAIL

Figure 20. Operator Restraint System

Engine Replacement

REMOVE

LPG Engine



WARNING

The lift truck must be put on blocks for some types of maintenance and repairs. The removal of the following assemblies will cause large changes in the center of gravity: mast, drive axle, engine and transmission, and counterweight. When the lift truck is put on blocks, put additional blocks in

the following positions to maintain stability:

- Before removing the mast and drive axle, put blocks under the counterweight so the lift truck cannot fall backward.
- Before removing the counterweight, put blocks under the mast assembly so the lift truck cannot fall forward.

The surface must be solid, even, and level when the lift truck is put on blocks. Make sure that any blocks used to support the lift truck are solid, one-piece units. See the Operating Manual or Periodic Maintenance 8000YRM1774.

**WARNING**

Always disconnect the cables at the battery before you make repairs to the engine. Disconnect the cable at the negative terminal first.

**WARNING**

LPG can cause an explosion. DO NOT cause sparks or permit flammable material near the LPG system. LPG fuel systems can be disconnected indoors only if the lift truck is at least 8 m (26 ft) from any open flame, motor vehicles, electrical equipments, or ignition source.

1. Close the shutoff valve on the LPG tank and run engine until all fuel is gone and engine stops.
2. For removal of the LPG Tank, see service manual **Fuel System PSI 2.4L 0900YRM1757** for the procedures.
3. Remove overhead guard. See section Overhead Guard Replacement for procedures.
4. Remove the floor mat and floor plate.

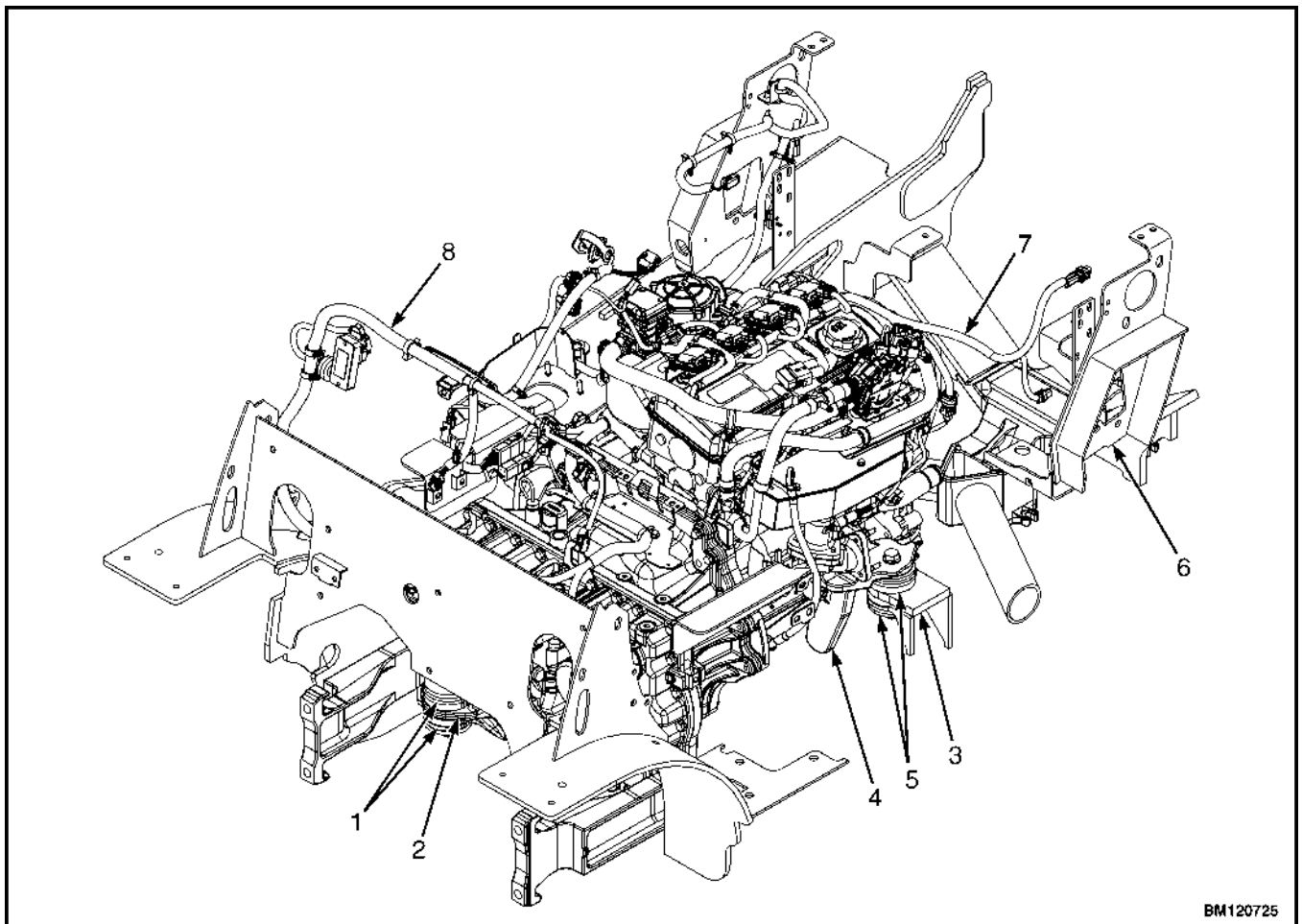

BM120725

NOTE: PART OF THE FRAME NOT SHOWN FOR CLARITY.

- | | |
|-----------------------------------|-----------------------------|
| 1. TRANSMISSION ISOLATOR ASSEMBLY | 5. ENGINE ISOLATOR ASSEMBLY |
| 2. TRANSMISSION MOUNTING BRACKET | 6. FRAME |
| 3. ENGINE MOUNTING BRACKET | 7. ENGINE WIRING HARNESS |
| 4. MOTOR MOUNT | 8. CHASSIS WIRING HARNESS |

Figure 21. PSI Engine and Transmission Mounting Arrangement

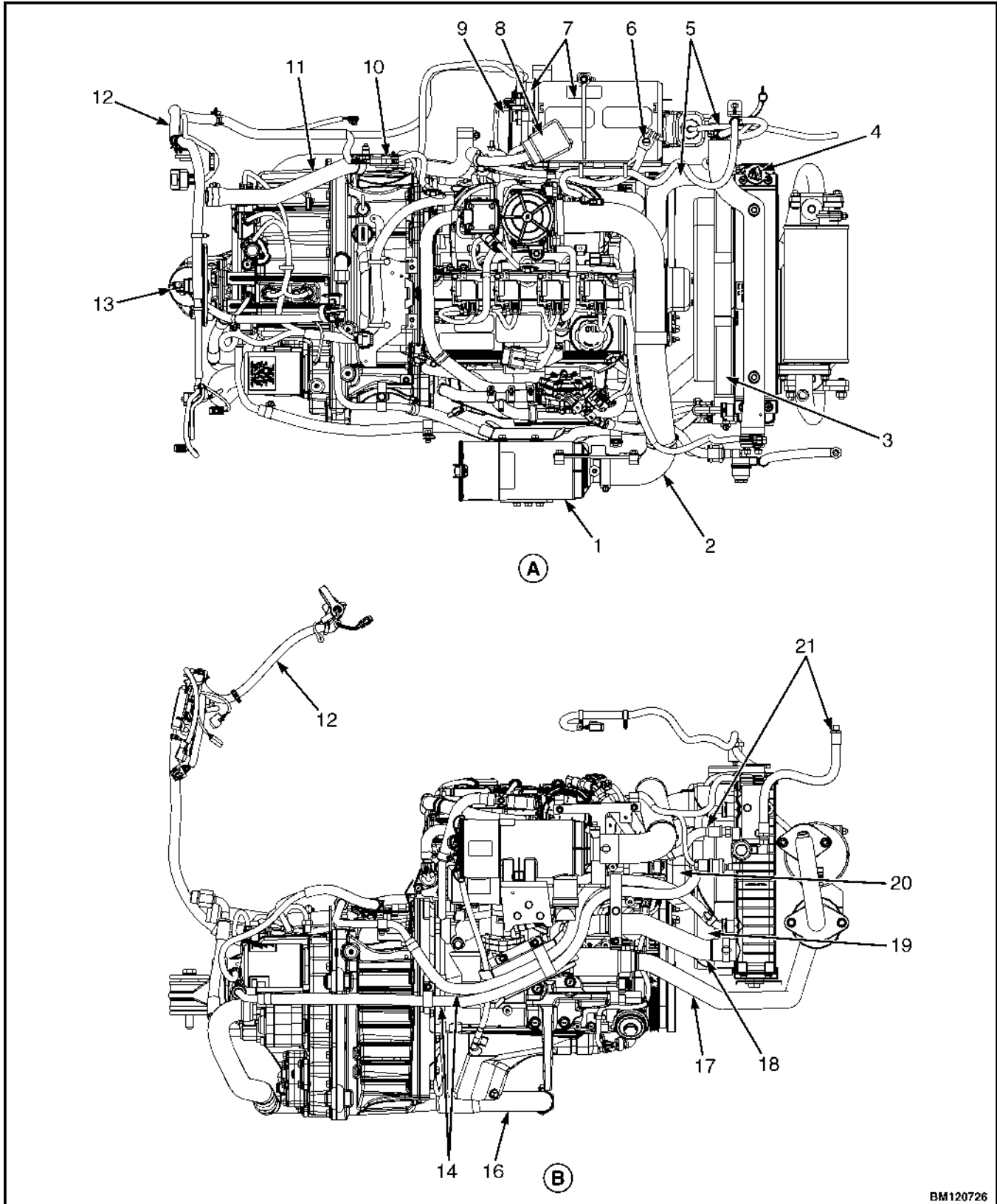

Figure 22. PSI Engine and Transmission Remove

Legend for Figure 22**A. TOP VIEW**

1. AIR FILTER AND BRACKET ASSEMBLY
2. AIR FILTER HOSE
3. SHROUD
4. RADIATOR CAP
5. COOLANT HOSES
6. NEGATIVE BATTERY CABLE
7. BATTERY AND BATTERY TRAY
8. POSITIVE BATTERY CABLE
9. PDM
10. ENGINE HARNESS CONNECTOR
11. HYDRAULIC RETURN HOSE

**WARNING**

DO NOT remove the radiator cap from the radiator when the engine is hot. When the radiator cap is removed, the pressure is released from the system. If the system is hot, the steam and boiling coolant can cause burns.

5. Let coolant cool to ambient temperature. Place a drain pan with a capacity greater than the capacity of the cooling system under radiator. Remove radiator cap.

**CAUTION**

Disposal of lubricants and fluids must meet local environmental regulations.

6. Open the drain plug or disconnect the bottom radiator hose to drain coolant from radiator and engine. See Figure 22.
7. Remove the hood and seat combination and rear side covers. See section Hood, Seat, and Side Covers Replacement for procedures.
8. Disconnect the ground strap from the frame and remove the power distribution module (PDM) from the battery tray. See Figure 23.
9. Remove battery and battery tray from lift truck as described in the steps below:
 - a. Remove cap, flange nut, and lockwasher from battery lockdown bar. See Figure 23.
 - b. Disengage battery lockdown bars and remove bar from top of battery. See Figure 23.
 - c. Remove battery from battery tray. See Figure 23.

B. LEFT VIEW

12. CHASSIS HARNESS
13. TRANSMISSION MOUNT
14. TRANSMISSION OIL COOLER LINES
15. LPG REGULATOR CONNECTOR
16. HYDRAULIC SUPPLY HOSE
17. EXHAUSTS PIPE TO EXHAUST MANIFOLD
18. LOWER RADIATOR HOSE
19. FAN
20. FAN PULLEY AND FAN SPACER
21. FUEL LINE

- d. Remove three capscrews and battery tray from frame. See Figure 23.

10. Disconnect the remaining coolant hoses from the radiator and cap them to prevent leakage. See Figure 22.

11. Remove the radiator fan pulley, shroud, and fan assembly. See **Cooling System - PSI 2.4L Engine 0700YRM1767** for the removal procedures.

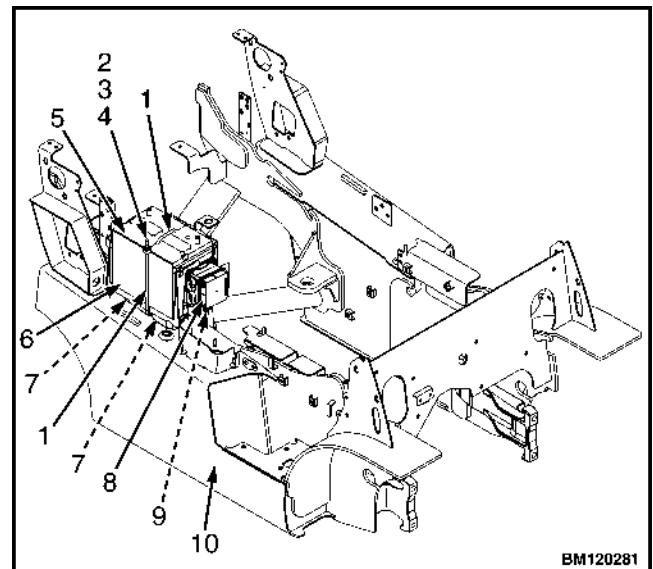

1. BATTERY LOCKDOWN BAR
2. CAP
3. FLANGE NUT
4. LOCKWASHER
5. BATTERY
6. BATTERY TRAY
7. CAPSCREW
8. PDM
9. GROUND STRAP
10. FRAME

Figure 23. Power Distribution Module and Battery Tray

 **WARNING**

All fuels are very flammable and can burn or cause an explosion. **DO NOT** use an open flame to check the fuel level or to check for leaks in the fuel system.

No smoking.

Breathing fuel vapor may cause nausea, unconsciousness, or death. Long-term exposure to gasoline vapors may cause liver or kidney damage and cancer. Avoid breathing vapor.

12. Disconnect the fuel lines at the engine. Put caps on fuel lines to prevent fuel leakage. See Figure 22.
13. Disconnect the engine harness connectors from the chassis harness connectors. See Figure 21.
14. Disconnect engine wiring harness connectors from proportional valve connectors, transducer connectors, solenoid valve connector, temperature sensor connector, and transmission. See Figure 24.
15. Remove exhaust pipe to exhaust manifold. See **Fuel System PSI 2.4L 0900YRM1757**
16. Use the access port on the side of engine and remove the four bolts that attached the flywheel to the torque converter. See Figure 25.
17. Connect a lifting device to the engine. Put a block under the transmission housing to support the transmission.
18. Remove four capscrews from torque converter housing and flywheel housing on transmission side. See Figure 26.

19. Remove six capscrews from flywheel housing and torque converter housing on flywheel housing side.

 **WARNING**

The engine is heavy. Make sure that any lifting device has enough capacity to lift the engine. The engine can weigh approximately 194 kg (428 lb).

20. Remove the flange nuts, washers, capscrews, and isolators from the engine mounts. Remove engine adapter to transmission bolts, if equipped. See Figure 21, Figure 27, and Figure 28.

 **CAUTION**

When separating the engine away from the transmission, place a piece of plywood in front of radiator. This will keep the engine from damaging the radiator.

 **CAUTION**

Keep the engine level when the engine is separated from the transmission so the drive plate is not damaged.

21. Use the lifting device to carefully move the engine away from the torque converter. Make sure all hoses, wires, and cables are disconnected from the engine, then lift the engine from the frame and place engine on blocks.
22. Remove torque converter from torque converter housing.

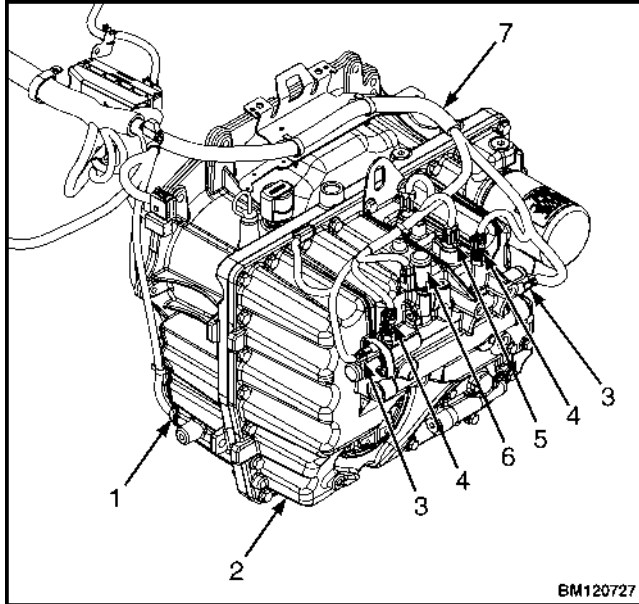

1. TEMPERATURE SENSOR CONNECTOR
2. TRANSMISSION HOUSING
3. PROPORTIONAL VALVE CONNECTOR
4. TRANSDUCER CONNECTOR
5. TRANSMISSION SENSOR PLUG
6. SOLENOID VALVE CONNECTOR
7. ENGINE WIRING HARNESS

Figure 24. Transmission Electrical Connectors

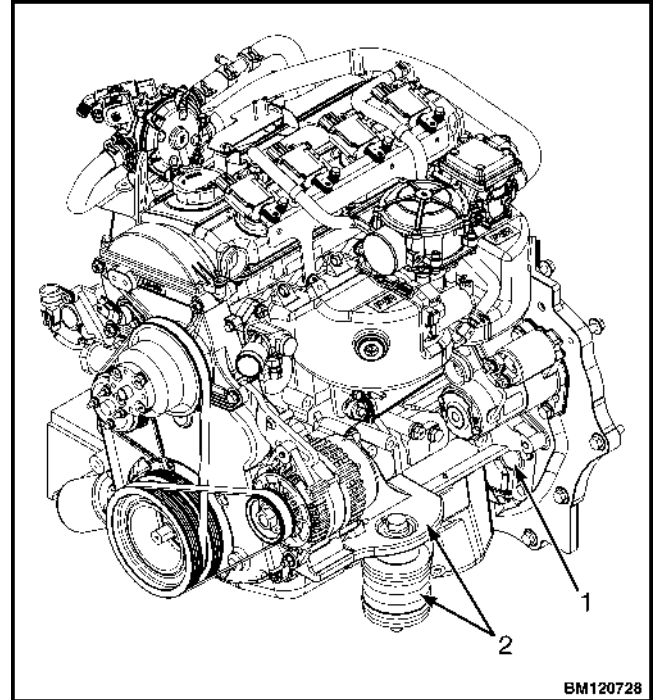

1. ACCESS PORT
2. ENGINE MOUNTING BRACKET AND HARDWARE

Figure 25. PSI Engine Removal Access Port

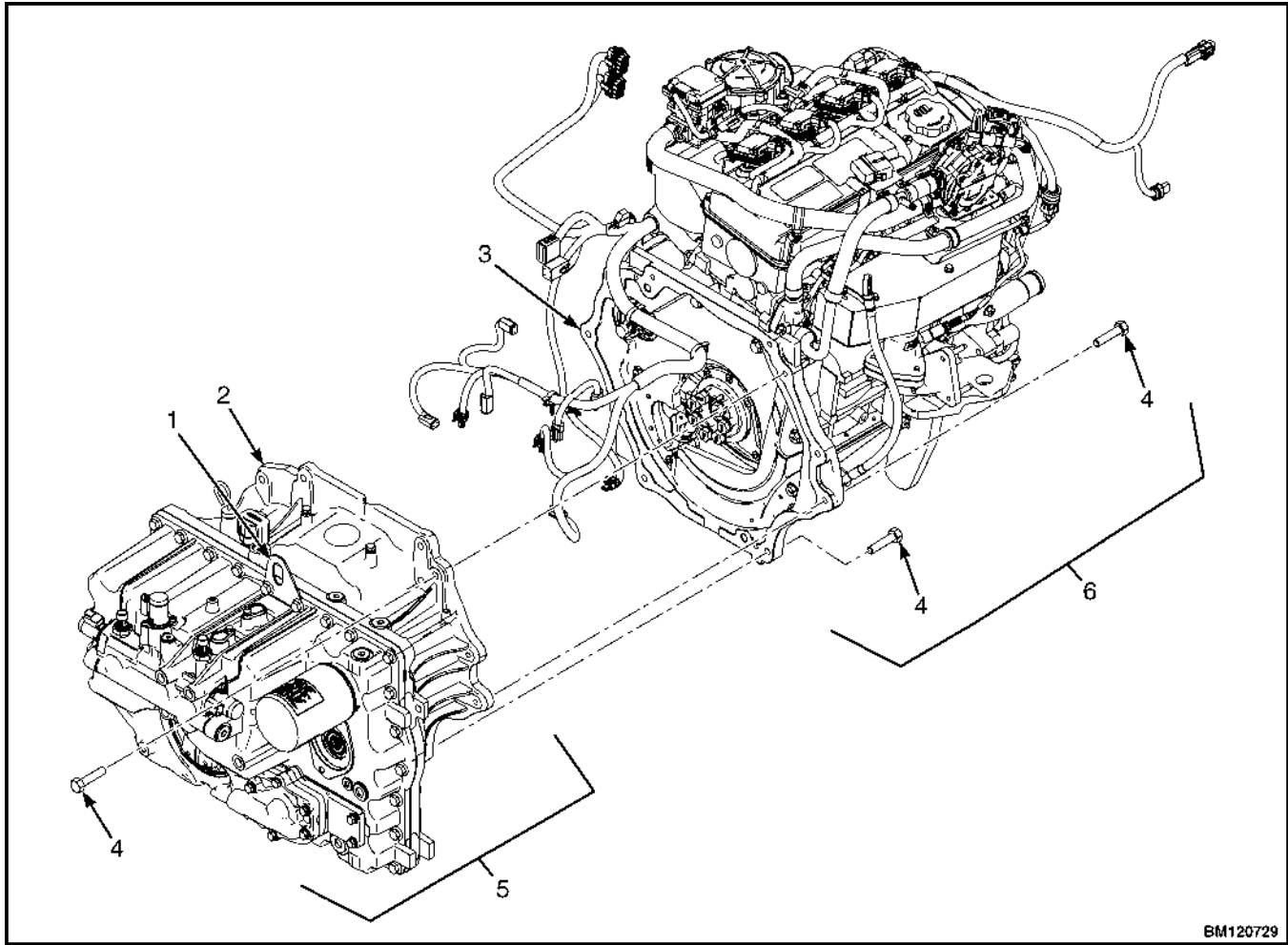

BM120729

1. EYEBOLT BRACKET
2. TORQUE CONVERTER HOUSING
3. FLYWHEEL HOUSING
4. CAPSCREW
5. TRANSMISSION ASSEMBLY
6. ENGINE ASSEMBLY

Figure 26. PSI Flywheel and Torque Converter Housings

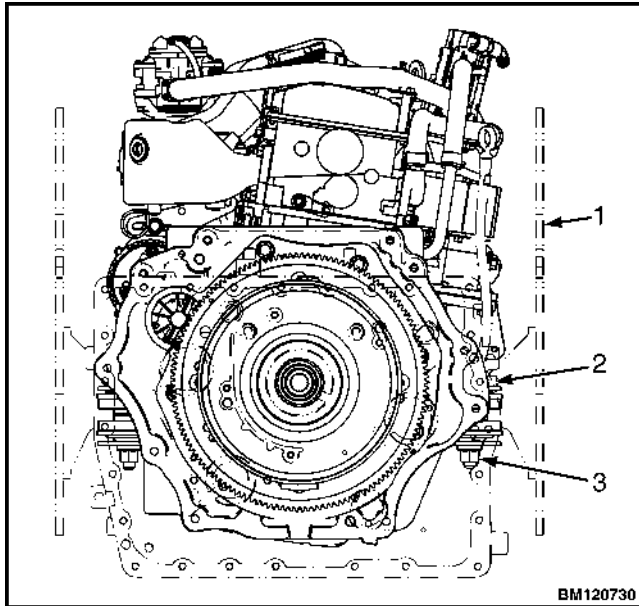

- 1. FRAME
- 2. ENGINE MOUNT
- 3. LOCK NUT

Figure 27. PSI Engine and Frame

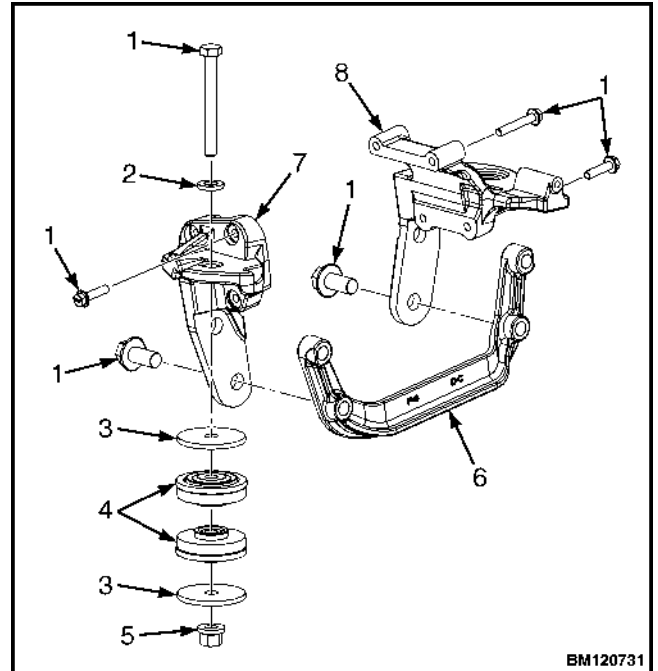

- 1. CAPSCREW
- 2. WASHER
- 3. SNUBBING WASHER
- 4. ISOLATOR
- 5. LOCKNUT
- 6. CROSSMEMBER (OPTIONAL)
- 7. LEFT ENGINE MOUNT
- 8. RIGHT ENGINE MOUNT

Figure 28. PSI Engine Mounts

Diesel Engine



WARNING

The lift truck must be put on blocks for some types of maintenance and repairs. The removal of the following assemblies will cause large changes in the center of gravity: mast, drive axle, engine and transmission, and counterweight. When the lift truck is put on blocks, put additional blocks in the following positions to maintain stability:

- Before removing the mast and drive axle, put blocks under the counterweight so the lift truck cannot fall backward.
- Before removing the counterweight, put blocks under the mast assembly so the lift truck cannot fall forward.

The surface must be solid, even, and level when the lift truck is put on blocks. Make sure that any blocks used to support the lift truck are solid, one-piece units. See the Operating Manual or the section Periodic Maintenance 8000YRM1774.



WARNING

Always disconnect the cables at the battery before you make repairs to the engine. Disconnect the cable at the negative terminal first.

1. Remove overhead guard. See section Overhead Guard Replacement for procedures.
2. Remove floor mast and floor plate.



WARNING

DO NOT remove the radiator cap from the radiator when the engine is hot. When the radiator cap is removed, the pressure is released from the system. If the system is hot, the steam and boiling coolant can cause burns.

3. Let coolant cool to ambient temperature. Place a drain pan with a capacity greater than the capacity of cooling system under radiator. Remove radiator cap.



CAUTION

Disposal of lubricants and fluids must meet local environmental regulations.

4. Open drain plug or disconnect bottom radiator hose to drain coolant from radiator and engine. See Figure 30.
5. Remove hood and seat combination and rear side covers. See section Hood, Seat, and Side Covers Replacement for procedures.
6. Disconnect ground strap from frame. Remove three flange bolts and power distribution module (PDM) from battery tray. See Figure 31.
7. Remove battery and battery tray from lift truck as described in the steps below:
 - a. Remove cap, flange nut, and lockwasher from battery lockdown bar. See Figure 31.
 - b. Disengage battery lockdown bars and remove bar from top of battery. See Figure 31.
 - c. Remove battery from battery tray. See Figure 31.
 - d. Remove three capscrews and battery tray from frame. See Figure 31.
8. Disconnect remaining coolant hoses from radiator and cap them to prevent leakage. See Figure 30.
9. Remove radiator fan pulley, shroud, and fan assembly. See **Cooling System - PSI 2.4L Engine** 0700YRM1767 for the removal procedures.



WARNING

All fuels are very flammable and can burn or cause an explosion. **DO NOT** use an open flame to check the fuel level or to check for leaks in the fuel system.

No smoking.

Breathing fuel vapor may cause nausea, unconsciousness, or death. Long term exposure to gasoline vapors may cause liver or kidney damage and cancer. **Avoid breathing vapor.**

10. Disconnect fuel lines at engine. Put caps on fuel lines to prevent fuel leakage. See Figure 30.
11. Disconnect engine harness connectors from chassis harness connectors. See Figure 29.

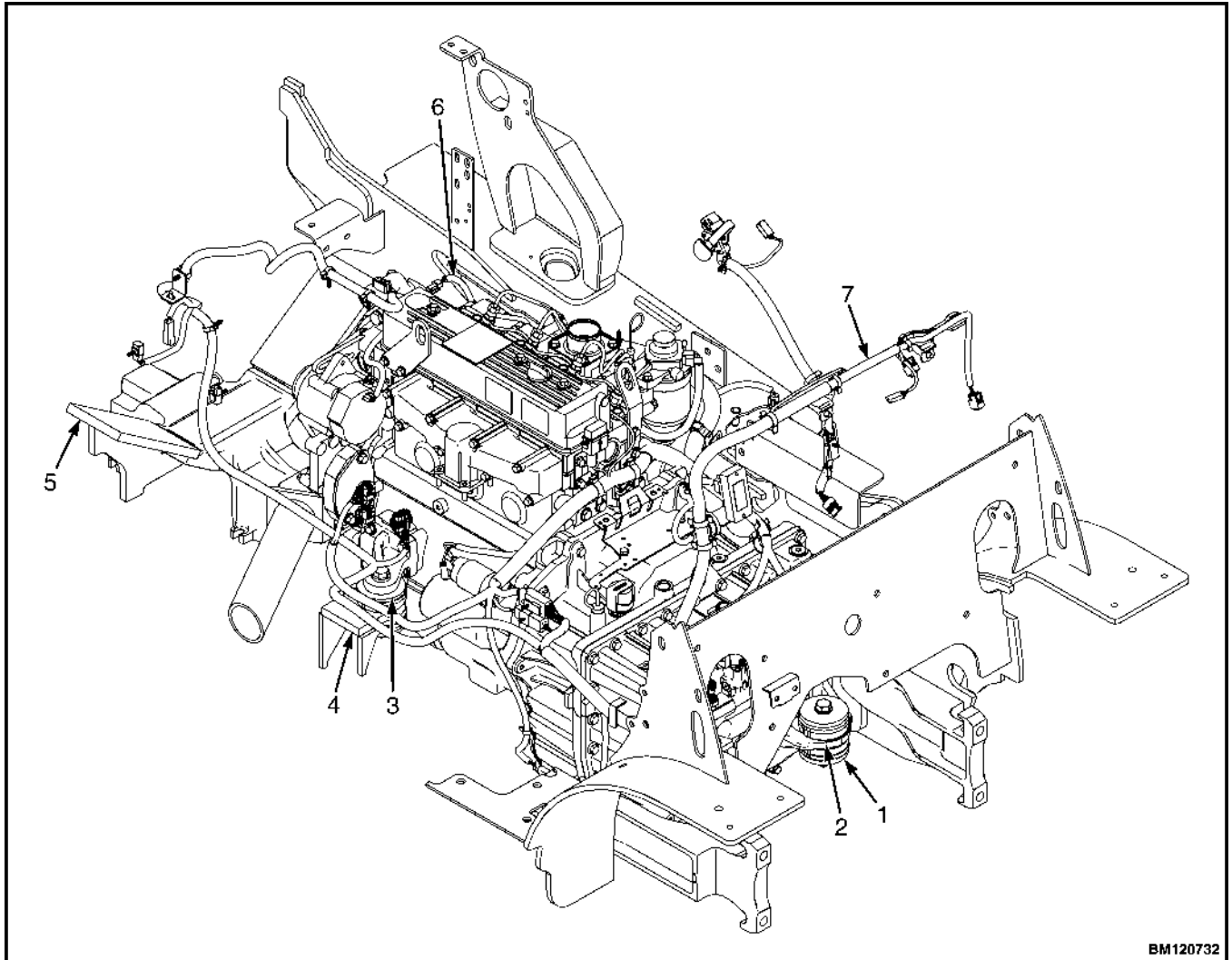

BM120732

NOTE: PART OF THE FRAME NOT SHOWN FOR CLARITY. LIFT TRUCK MODELS GDP25LX (GDP050LX) (B974) SHOWN.

- | | |
|----------------------------------|---------------------------|
| 1. TRANSMISSION ISOLATOR | 5. FRAME |
| 2. TRANSMISSION MOUNTING BRACKET | 6. ENGINE WIRING HARNESS |
| 3. ENGINE ISOLATOR | 7. CHASSIS WIRING HARNESS |
| 4. ENGINE MOUNTING BRACKET | |

Figure 29. Yanmar Diesel Engine and Transmission Mounting Arrangement

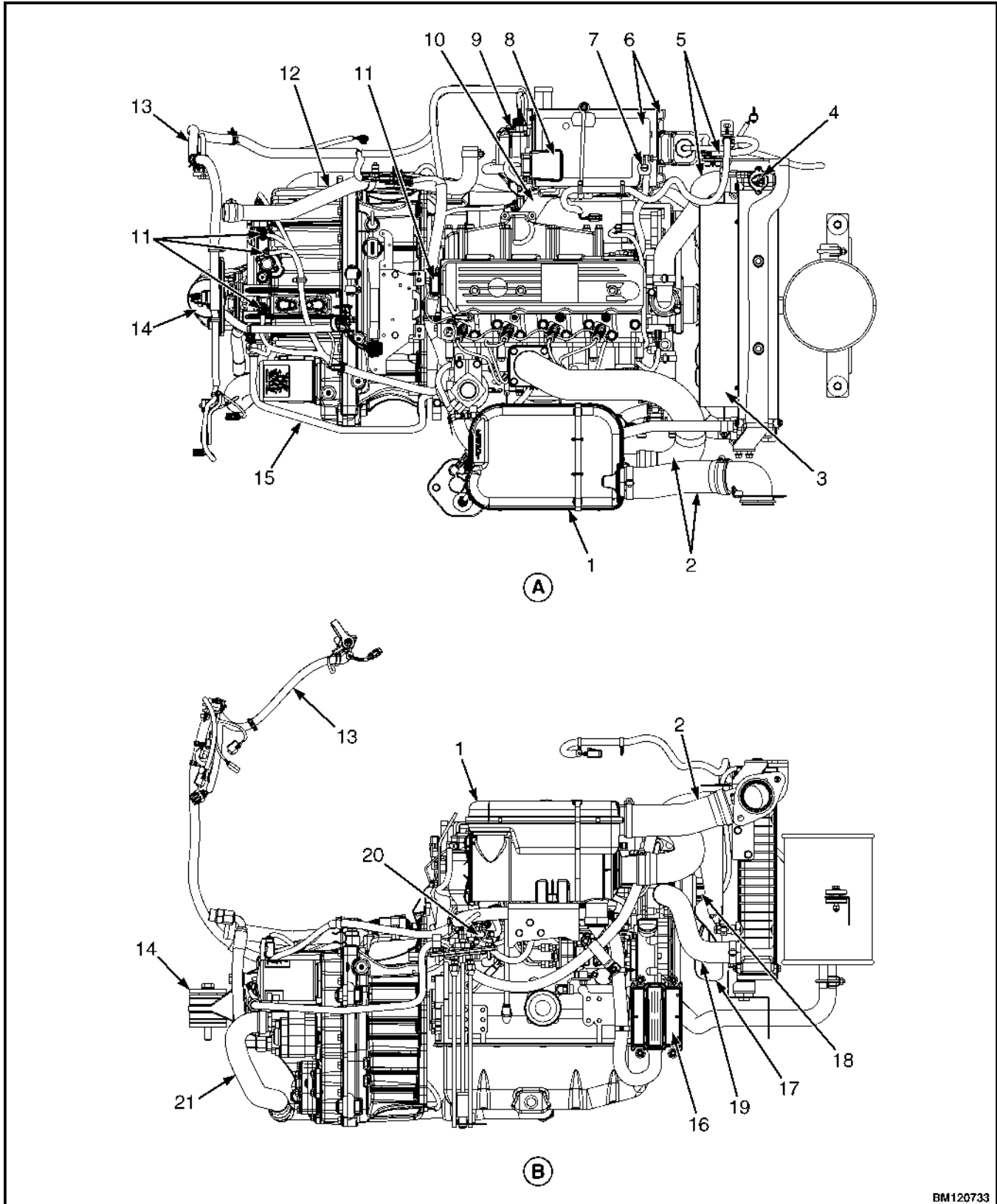
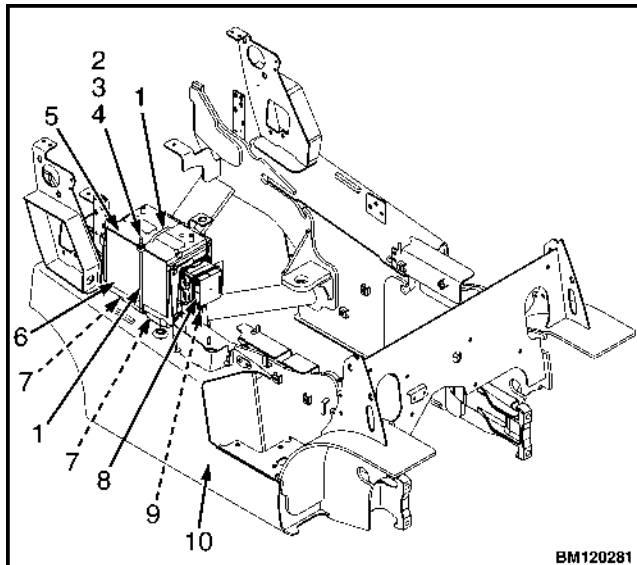

Figure 30. Yanmar 2.6L Diesel Engine and Transmission Removal

Legend for Figure 30**A. TOP VIEW**

1. AIR FILTER AND BRACKET ASSEMBLY
2. AIR FILTER HOSE
3. SHROUD
4. RADIATOR CAP
5. COOLANT HOSES
6. BATTERY AND BATTERY TRAY
7. BATTERY CABLE (NEGATIVE)
8. BATTERY CABLE (POSITIVE)
9. POWER DISTRIBUTION MODULE (PDM)
10. EXHAUST PIPE TO EXHAUST MANIFOLD
11. ENGINE HARNESS CONNECTOR



1. BATTERY LOCKDOWN BAR
2. CAP
3. FLANGE NUT
4. LOCKWASHER
5. BATTERY
6. BATTERY TRAY
7. CAPSCREW
8. PDM
9. GROUND STRAP
10. FRAME

Figure 31. Power Distribution Module and Battery Tray

B. LEFT VIEW

12. HYDRAULIC RETURN HOSE
13. CHASSIS HARNESS
14. TRANSMISSION MOUNT
15. TRANSMISSION OIL COOLER LINES
16. ELECTRONIC CONTROL MODULE (ECM) AND BRACKET
17. FAN
18. FAN PULLEY AND FAN SPACER
19. BOTTOM RADIATOR HOSE
20. FUEL LINE
21. HYDRAULIC SUPPLY HOSE

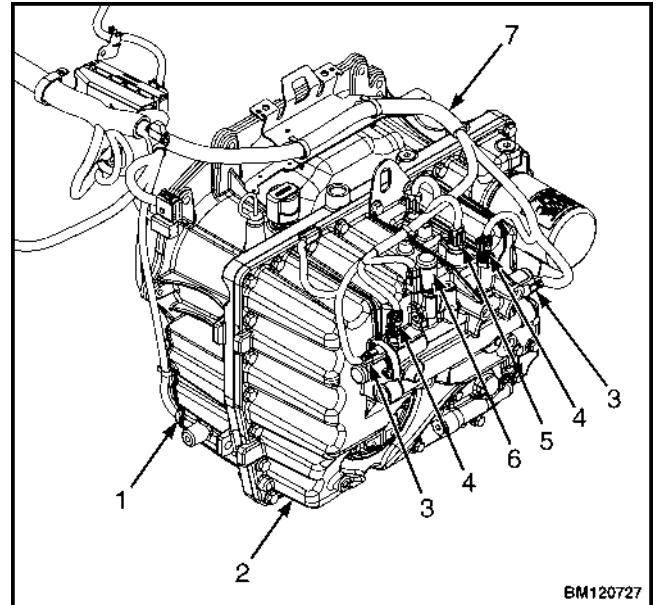

1. TEMPERATURE SENSOR CONNECTOR
2. TRANSMISSION HOUSING
3. PROPORTIONAL VALVE CONNECTOR
4. TRANSDUCER CONNECTOR
5. TRANSMISSION SENSOR PLUG
6. SOLENOID VALVE CONNECTOR
7. ENGINE WIRING HARNESS

Figure 32. Transmission Electrical Connectors

12. Disconnect engine wiring harness connectors from proportional valve connectors, transducer connectors, solenoid valve connector, temperature sensor connector, and transmission. See Figure 32.
13. Use the access port on the side of engine and remove four bolts attaching flywheel to torque converter. See Figure 33.
14. Connect lifting device to engine. Put a block under transmission housing to support transmission.
15. Remove four flange bolts from torque converter housing and flywheel housing on transmission side. See Figure 34.

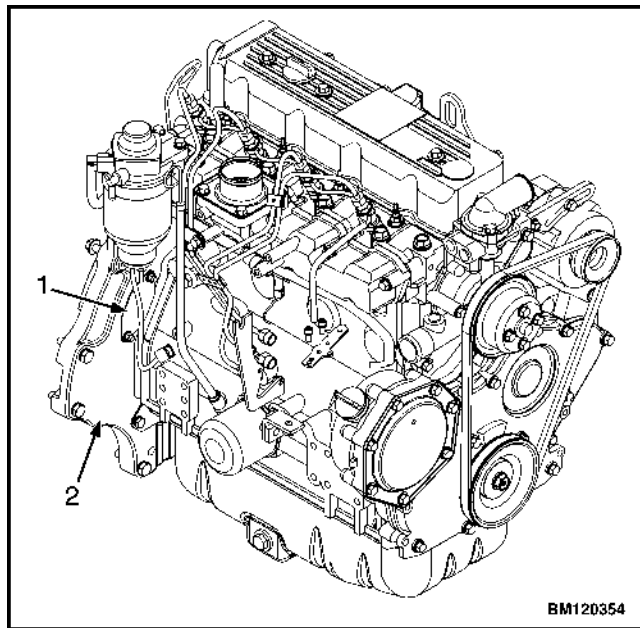

1. ACCESS PORT
2. FLYWHEEL HOUSING

Figure 33. Yanmar Torque Converter Bolt Access

16. Remove six hex head capscrews and six lock-washers from flywheel housing and torque converter housing on flywheel housing side. See Figure 34.

WARNING

The engine is heavy. Make sure that any lifting device has enough capacity to lift the engine.

The engine can weigh approximately 194 kg (428 lb).

17. Remove flange locknuts, washers, snubbing washers, capscrews, and isolators from the engine mounts. Remove engine adapter to transmission bolts, if equipped. See Figure 35.

CAUTION

When separating the engine away from the transmission, place a piece of plywood in front of radiator. This will keep the engine from damaging the radiator.

CAUTION

Keep the engine level when the engine is separated from the transmission so the drive plate is not damaged.

18. Use a lifting device to carefully move engine away from torque converter. Make sure all hoses, wires, and cables are disconnected from the engine, then lift the engine from the frame and place engine on blocks.
19. Remove torque converter from torque converter housing.

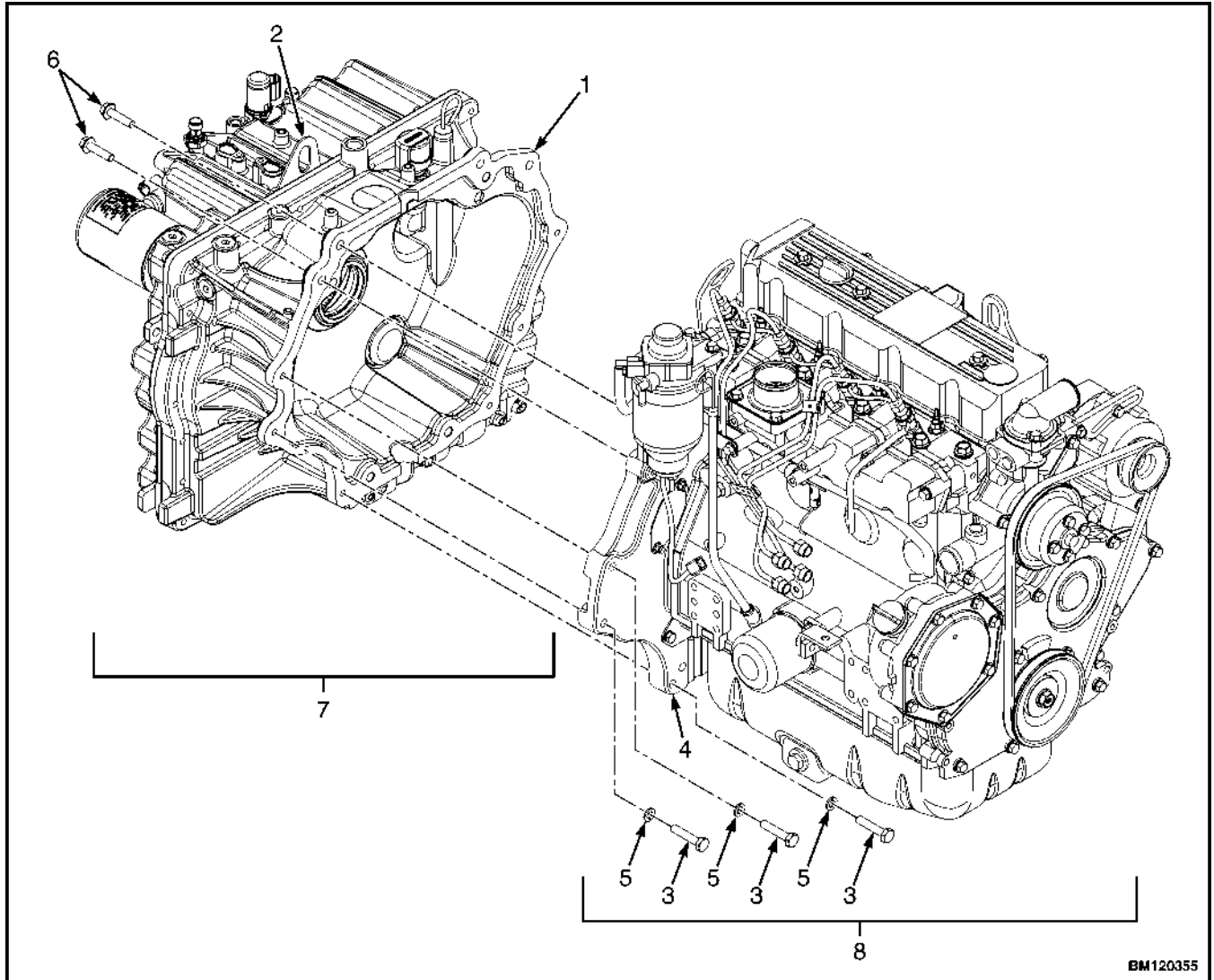

BM120355

- | | |
|-----------------------------|--------------------------|
| 1. TORQUE CONVERTER HOUSING | 5. LOCKWASHER |
| 2. EYEBOLT BRACKET | 6. FLANGE BOLT |
| 3. HEX HEAD CAPSCREW | 7. TRANSMISSION ASSEMBLY |
| 4. FLYWHEEL HOUSING | 8. ENGINE ASSEMBLY |

Figure 34. Yanmar Flywheel and Torque Converter Housings

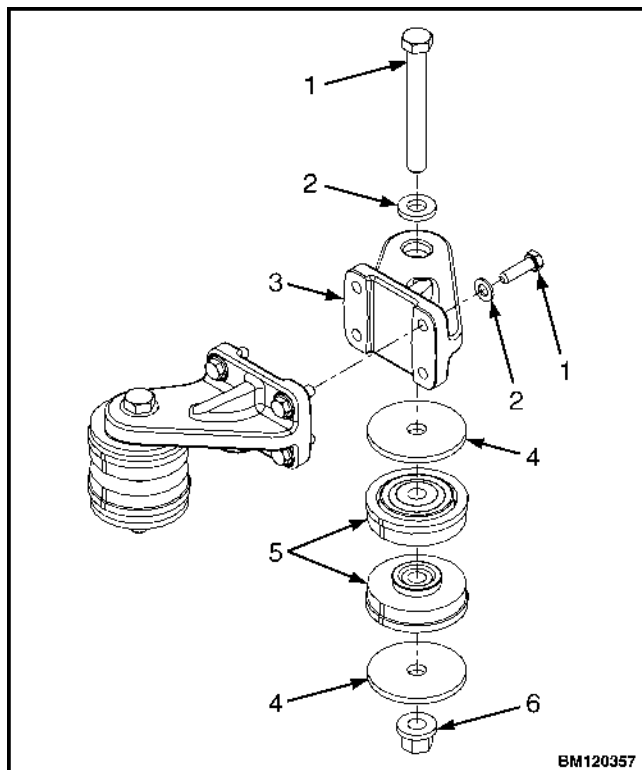

1. CAPSCREW
2. WASHER
3. ENGINE BRACKET
4. SNUBBING WASHER
5. ISOLATOR
6. FLANGE LOCKNUT

Figure 35. Yanmar Engine Mounts

INSTALL

LPG Engine

WARNING

The engine is heavy. Make sure that any lifting device has enough capacity to lift the engine. The engine can weigh approximately 194 kg (428 lb).

CAUTION

Keep the engine level when installing the engine to the transmission so the drive plate is not damaged.

1. Install torque converter in torque converter housing.
2. Connect lifting device to engine and lift engine into frame. Install engine adapter to transmission bolts.

3. Install isolators, bolts, washers, and flange nuts on engine mounts. See Figure 21, Figure 27, and Figure 28. Tighten the flange nuts to 150 N•m (110 lbf ft).
4. Use access port on side of engine and install bolts to hold torque converter to flywheel. Tighten bolt to 56 N•m (41 lbf ft). See Figure 25.
5. Align torque converter housing holes with flywheel housing holes and install four capscrews from torque converter housing side. Tighten capscrews to 38 N•m (28 lbf ft). See Figure 26.
6. Install six capscrews in torque converter housing and flywheel housing from flywheel housing side. Tighten capscrews to 38 N•m (28 lbf ft). See Figure 26.
7. Install exhaust pipe to exhaust manifold. See **Fuel System PSI 2.4L** 0900YRM1757.
8. Connect engine wiring harness connectors to proportional valve connectors, transducer connectors, solenoid valve connector, temperature sensor connector, and transmission. See Figure 24.
9. Connect chassis wiring harness connectors to engine harness connectors. See Figure 21.

WARNING

All fuels are very flammable and can burn or cause an explosion. **DO NOT** use an open flame to check the fuel level or to check for leaks in the fuel system.

No smoking.

Breathing fuel vapor may cause nausea, unconsciousness, or death. Long-term exposure to gasoline vapors may cause liver or kidney damage and cancer. Avoid breathing vapor.

10. Remove caps from fuel lines and connect the fuel lines at the engine.
11. Install the radiator shroud, fan pulley, and fan assembly. See Figure 22. See **Cooling System - PSI 2.4L Engine** 0700YRM1767 for the installation procedures.
12. Connect the coolant hoses and lines to the transmission. Fill cooling system with a mixture specified in **Periodic Maintenance** 8000YRM1774.

13. Connect the PDM and connect the ground strap to lift truck frame and attach it to battery.
14. Install battery and battery tray. See Figure 23.
15. Install LPG tank and bracket on lift truck. See **Fuel System PSI 2.4L** 0900YRM1757 for the procedures.
16. Install the rear side covers, floor plates, and hood and seat combination. See section Hood, Seat, and Side Covers Replacement for the procedures.
17. If removed, install overhead guard. See section Overhead Guard Replacement for procedures.
18. Check all fluid levels and fill as needed. See **Periodic Maintenance** 8000YRM1774 for quantities and procedures.

**CAUTION**

Disposal of lubricants and fluids must meet local environmental regulations.

19. Empty drain pan contents.
20. Swing LPG tank into position on back of counterweight and open shutoff valve on tank.

Diesel Engine**WARNING**

The engine is heavy. Make sure that any lifting device has enough capacity to lift the engine. The engine can weight approximately 194 kg (428 lb).

**CAUTION**

Keep the engine level when installing the engine to the transmission so the drive plate is not damaged.

1. Install torque converter in torque converter housing.
2. Connect lifting device to engine and lift engine into frame. Install engine adapter to transmission bolts, if equipped.
3. Install isolators, capscrews, washers, snubbing washers, and flange locknuts on engine mounts. See Figure 35. Tighten flange locknuts to 150 N•m (110 lbf ft).

4. Use access port on side of engine and install four bolts attached flywheel to torque converter. See Figure 33. Tighten bolts to 55 N•m (41 lbf ft).
5. Install six hex head capscrews and six lockwashers on flywheel housing and torque converter housing on torque converter housing side. See Figure 34. Tighten capscrews to 38 N•m (28 lbf ft).
6. Install four flange bolts on flywheel housing and torque converter housing on transmission side. See Figure 34. Tighten capscrews to 38 N•m (28 lbf ft).
7. Connect engine wiring harness connectors to transmission, temperature sensor connector, solenoid valve connector, transducer connectors, and proportional valve connectors. See Figure 32.
8. Connect engine wiring harness connectors to chassis harness connectors. See Figure 29.

**WARNING**

All fuels are very flammable and can burn or cause an explosion. DO NOT use an open flame to check the fuel lever or to check for leaks in the fuel system.

No smoking.

Breathing fuel vapor may cause nausea, unconsciousness, or death. Long term exposure to gasoline vapors may cause liver or kidney damage and cancer. Avoid breathing vapor.

9. Remove caps from fuel lines and connect lines at engine. See Figure 30.
10. Install radiator shroud, fan pulley, and fan assembly. See Figure 30. See **Cooling System - PSI 2.4L Engine** 0700YRM1767 for the installation procedures.
11. Connect coolant hoses and lines to transmission. Fill cooling system with a mixture specified in **Periodic Maintenance** 8000YRM1774.
12. Install battery tray and battery as described in the steps below:
 - a. Install battery tray and three capscrews on frame. See Figure 31.
 - b. Install battery in battery tray. See Figure 31.

- c. Install battery lockdown bar on top of battery and engage with bar on side of battery tray. See Figure 31.
 - d. Install lockwasher and flange nut on battery lockdown bar. Tighten flange nut to 2.0 to 2.5 N•m (18 to 22 lbf in). Install cap on battery lockdown bar. See Figure 31.
13. Install power distribution module (PDM) and three flange bolts on battery tray. Tighten flange bolts to 3.2 to 3.5 N•m (28 to 31 lbf in). Connect the PDM to chassis wire harness. Install ground strap on frame. See Figure 31.
 14. Install rear side covers and hood and seat combination. See section Hood, Seat, and Side Covers Replacement for procedures.
 15. Install overhead guard. See section Overhead Guard Replacement for procedures.
 16. Check all fluid levels and fill as needed. See **Periodic Maintenance** 8000YRM1774 for quantities and procedures.

**CAUTION**

Disposal of lubricants and fluids must meet local environmental regulations.

17. Empty drain pan contents.

Transmission Replacement

REMOVE**WARNING**

The lift truck must be put on blocks for some types of maintenance and repairs. The removal of the following assemblies will cause large changes in the center of gravity: mast, drive axle, engine, transmission, and counterweight. When the lift truck is put on blocks put additional blocks in the following positions to maintain stability:

- Before removing the mast and drive axle, put blocks under the counterweight so the lift truck cannot fall backward.
- Before removing the counterweight, put blocks under the mast assembly so the lift truck cannot fall forward.

The surface must be solid, even, and level when the lift truck is put on blocks. Make sure that any blocks used to support the lift truck are solid, one piece units. See the Operating Manual or Periodic Maintenance 8000YRM1774.

**WARNING**

The transmission is heavy. Make sure that any lifting device has enough capacity to lift the weight. The transmission can weigh approximately 83.8 kg (184.7 lb).

NOTE: Make sure the transmission is supported by blocks or a lifting device before removing the engine.

1. Remove engine from lift truck. See section Remove, Engine Replacement for procedures.
2. Remove seal plate for brake and throttle pedals. See Figure 6.

**CAUTION**

Disposal of lubricants and fluids must meet local environmental regulations.

3. Place a suitable container under transmission. Disconnect transmission cooling lines.
4. Remove drain fitting from transmission housing and drain transmission oil. See Figure 36.
5. Disconnect and cap suction hose from hydraulic gear pump inlet port. Cap hydraulic gear pump inlet port. See Figure 36.
6. Disconnect and cap hydraulic hose from hydraulic gear pump outlet port. Cap hydraulic gear pump outlet port. See Figure 36.
7. Connect a lifting device to the eyebolt bracket. See Figure 26.
8. Remove capscrew, washer, snubbing washers, and isolators from the mount bracket at the rear of the transmission. See Figure 37.
9. Use the lifting device to carefully lift the transmission from the frame.

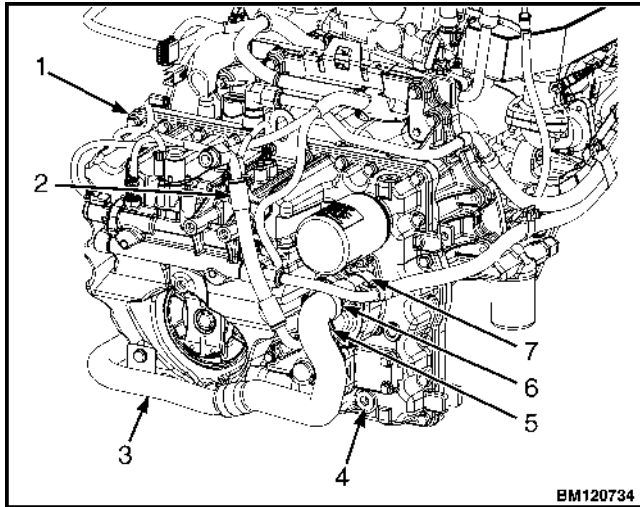

NOTE: PSI ENGINE SHOWN FOR REFERENCE ONLY.

1. TRANSMISSION HOUSING
2. HYDRAULIC HOSE
3. SUCTION HOSE
4. DRAIN FITTING
5. HYDRAULIC GEAR PUMP INLET PORT
6. HYDRAULIC GEAR OUTLET PUMP
7. HYDRAULIC GEAR PUMP

Figure 36. Hydraulic Hose, Aluminum Transmission Housing

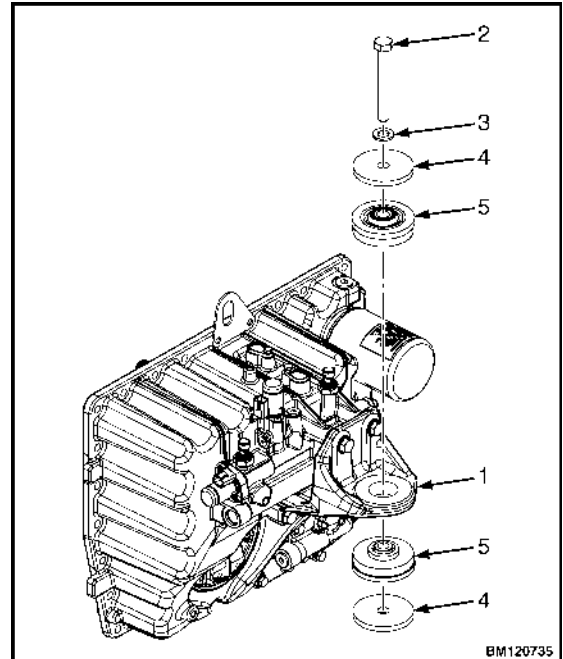

NOTE: DRIVE AXLE NOT SHOWN FOR CLARITY.

1. MOUNTING BRACKET
2. CAPSCREW
3. WASHER
4. SNUBBING WASHER
5. ISOLATOR

Figure 37. Rear Mount-Transmission

10. Remove flange head capscrew, yoke, and spacer from transmission housing. Make sure to not damage the oil seal. Remove and discard stat-o-seal from yoke. See Figure 38.

NOTE: Note position of oil seal prior to removal to aid in installation.

11. Remove oil seal from transmission housing. See Figure 38.

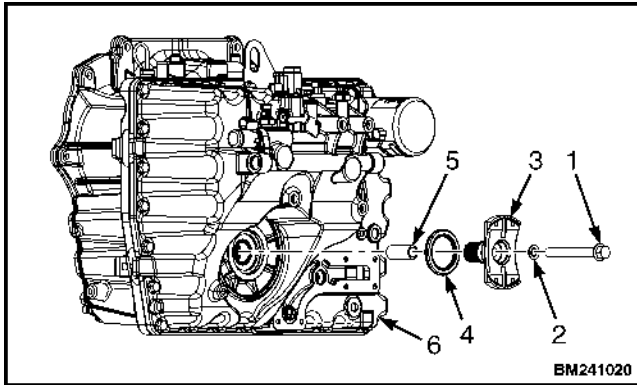

1. FLANGE HEAD CAPSCREW
2. STAT-O-SEAL
3. YOKE
4. OIL SEAL
5. SPACER
6. TRANSMISSION HOUSING

Figure 38. Drive Shaft Yoke

INSTALL



WARNING

The transmission is heavy. Make sure that any lifting device has enough capacity to lift the weight. The transmission can weigh approximately 83.8 kg (184.7 lb).

1. Using a lifting device, install transmission in lift truck frame. Place a block under the transmission housing to support the transmission.
2. Install oil seal on back of transmission housing. See Figure 38.
3. Install new stat-o-seal on yoke. See Figure 38.
4. Install spacer, yoke, and flange head capscrew on back of transmission housing. See Figure 38. Tighten capscrew to 77 N•m (57 lbf ft).
5. Install isolators, snubbing washers, washer, and capscrew on mounting bracket at the rear of the transmission. See Figure 37. Tighten capscrew to 225 to 250 N•m (166 to 184 lbf ft).
6. Connect hydraulic hose to hydraulic gear pump outlet port. See Figure 36.
7. Connect suction hose to hydraulic gear pump inlet port. See Figure 36.
8. Install drain fitting on transmission housing. See Figure 36.
9. Connect transmission cooling line to transmission. See Figure 36.
10. Install seal plate for brake and throttle pedals. See Figure 6.
11. Install engine in lift truck. See section Install, Engine Replacement for procedures.
12. Remove lifting device from eyebolt or eyebolt bracket on transmission.
13. Fill transmission oil. For fill instruction, oil type, and amount see the section **Periodic Maintenance** 8000YRM1774.

Throttle Pedal and Cable Adjustment

PSI 2.4L ENGINE

Throttle Pedal Stop Adjustment

The PSI 2.4L dual fuel or LPG engines used on lift trucks covered in this manual have an electronic throttle that is self-adjusting and self-calibrating. There is only a throttle pedal stop adjustment. To replace the throttle pedal position sensor, see **Electrical System 2200YRM1771**.

1. Fully depress throttle pedal and adjust pedal stop so that it touches floor plate. Tighten jam nut to 10 N•m (88.5 lbf in). See Figure 39.

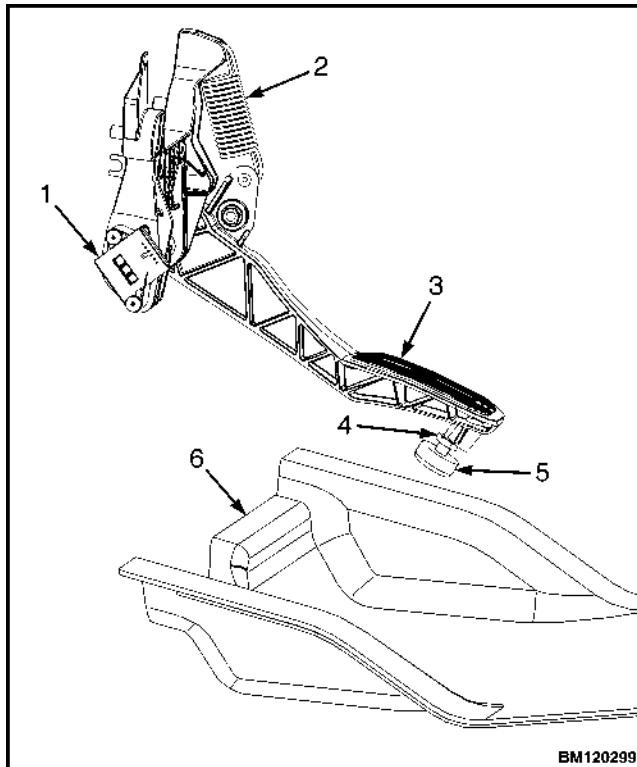

1. THROTTLE PEDAL POSITION SENSOR
2. SPRING
3. THROTTLE PEDAL
4. ADJUSTING NUT
5. PEDAL STOP
6. FLOOR PLATE

Figure 39. Throttle Pedal Stop Adjustment, PSI 2.4L Engines

YANMAR DIESEL ENGINE

1. Remove floor plate and disconnect throttle cable from bellcrank and engine.
2. Fully depress throttle pedal and verify that the dimension between the bellcrank and cowl plate is 5 ± 1 mm (0.20 ± 0.04 in.). See Figure 40.
3. If dimension is not correct, adjust ball ends on push rod so that a minimum of 6 mm (0.24 in.) of threaded rod screws into each ball end. After adjusting push rod, tighten jam nuts to 8 to 15 N•m (71 to 133 lbf in).
4. Connect throttle cable to bellcrank and engine. See Figure 40.
5. With throttle pedal in full up position, adjust throttle cable, using jam nuts (10, Figure 40) to remove all slack from cable. Cable should be adjusted to the point where additional adjustment will pull control lever off idle stop. Tighten jam nuts 8 to 15 N•m (71 to 133 lbf in).
6. Install floor plate. Fully depress throttle pedal and adjust pedal stop so that it touches floor plate. Tighten jam nuts (6, Figure 40) to 8 to 15 N•m (71 to 133 lbf in).

YANMAR DIESEL ENGINE WITH ELECTRONIC THROTTLE

If lift truck is equipped with an electronic throttle, see section **Yanmar Diesel Engines 0600YRM1205** for adjustment procedures.

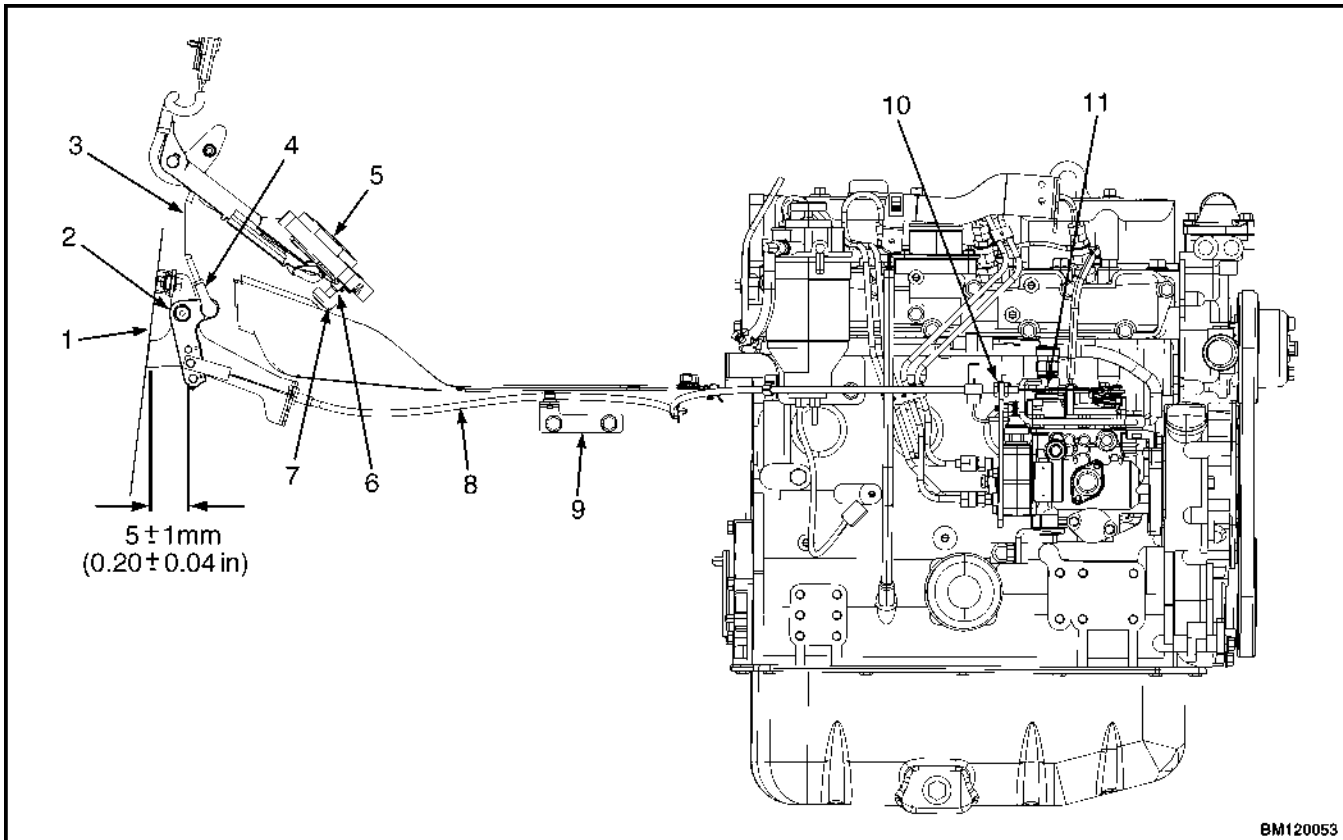

NOTE: THROTTLE PEDAL NOT SHOWN IN FULLY DEPRESSED POSITION (WIDE OPEN POSITION).

NOTE: MOUNTING BRACKET FOR THREE FUNCTION CONTROL VALVE SHOWN, FOUR FUNCTION CONTROL VALVE SIMILAR.

- | | |
|-------------------|--------------------|
| 1. COWL | 7. PEDAL STOP |
| 2. BELLCRANK | 8. THROTTLE CABLE |
| 3. PUSH ROD | 9. CABLE BRACKET |
| 4. BALL END | 10. JAM NUTS |
| 5. THROTTLE PEDAL | 11. THROTTLE CRANK |
| 6. JAM NUT | |

Figure 40. Throttle Pedal and Cable Adjustment, Yanmar Diesel Engine

Cooling System

DESCRIPTION

The cooling system is used to cool the engine and keep it at the correct operating temperature. The cooling system is comprised of the following main components:

- Radiator
- Fan and belt
- Fan shroud

- Coolant hoses and lines
- Coolant reservoir

For the procedures to repair, clean, inspect, and install the radiator and cooling system components, refer to **Cooling System - PSI 2.4L Engine 0700YRM1767**.

Hydraulic Filter Repair

REMOVE



WARNING

At operating temperature, the hydraulic oil is HOT. DO NOT permit the hot oil to touch the skin and cause a burn.



CAUTION

DO NOT permit dirt to enter the hydraulic system when the oil level is checked or the filter is changed. Dirt can cause damage to the components of the hydraulic system.

Never operate the hydraulic pump without oil in the hydraulic system. The operation of the hydraulic pump without oil will damage the pump.



CAUTION

Disposal of lubricants and fluids must meet local environmental regulations.

1. Put lift truck on level surface and lower carriage.
2. Unscrew and remove lid and spring from head. Remove and discard O-ring from lid. See Figure 41.

NOTE: Have container large enough to hold filter element and allow for final hydraulic oil draining.

NOTE: Note placement of filter element and handle prior to removal to aid in installation.

3. Remove filter element and O-ring from filter housing and place in container. Cover head to prevent any foreign material from getting into the hydraulic tank. See Figure 41.
4. After filter element has drained, discard filter element and O-ring.
5. Remove and discard quad ring from filter housing. See Figure 41.

CLEAN AND INSPECT

1. Clean housing and cover plate as necessary.
2. Inspect filter housing, especially sealing surfaces, for damage. Replace, if damaged.

3. Inspect dipstick plug. Replace O-ring and plug as necessary.

INSTALL

1. Lubricate sealing surfaces on filter housing with clean hydraulic oil.
2. Lubricate new quad ring with clean hydraulic oil and install onto filter housing. See Figure 41.
3. Lubricate new O-ring with clean hydraulic oil and install on bottom of new filter element. See Figure 41.
4. Install new filter element into filter housing as noted during removal. See Figure 41.
5. Lubricate new O-ring with clean hydraulic oil and install on lid. See Figure 41.
6. Install spring and lid onto filter housing. See Figure 41. Tighten lid to 14 N•m (124 lbf in).

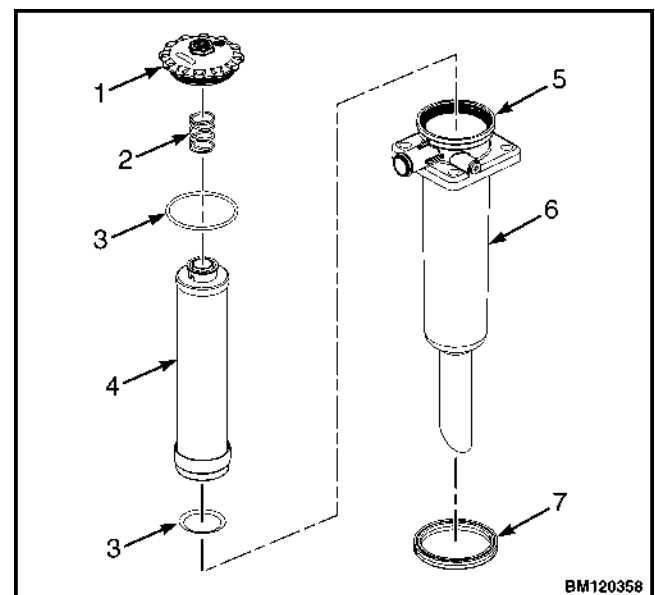

- | | |
|-------------------|-------------------|
| 1. LID | 5. HEAD |
| 2. SPRING | 6. FILTER HOUSING |
| 3. O-RING | 7. QUAD RING |
| 4. FILTER ELEMENT | |

Figure 41. Hydraulic Filter

**CAUTION**

Additives may damage the hydraulic system. Before using additives, contact your local Yale dealer.

7. Start lift truck, and allow it to run for 30 seconds. Check for leaks. Stop engine and check hydraulic oil level. Add oil, if necessary. Use hydraulic oil indicated in **Periodic Maintenance** 8000YRM1774.

Tank Repair

HYDRAULIC AND DIESEL TANKS

Inspect

**WARNING**

Special procedures must be followed when large leaks or other repairs need welding or cutting. All work must be done by authorized personnel. If the tank is cleaned inside a building, make sure there is enough ventilation. See the following manuals for additional information:

- *Safe Practices for Welding and Cutting Containers That Have Held Combustibles* by the American Welding Society, F4.1 - 1999.
- *Safety in Welding and Cutting*, American National Standard, AWS Z 49.1 - 1999.

**WARNING**

DO NOT use tools that can make sparks, heat, or static electricity. The vapors in the tank can cause an explosion.

**CAUTION**

Additives may damage the hydraulic system. Before using additives, contact your local Yale dealer.

Make a visual inspection of all sides of the tank. Inspect the welds for cracks and leakage. Check for wet areas, accumulation of dirt, and loose or missing paint caused by leakage. Areas of the tank that are not easily seen can be checked with an inspection mirror and a light that is approved for locations with flammable vapors.

Clean

**WARNING**

When cleaning the tank, do not use solutions that make dangerous gases at normal temperatures or when heated. Wear eye and face protection. Protect the body from burns.

**WARNING**

Compressed air can move particles so that they cause injury to the user or to other personnel. Make sure that the path of the compressed air is away from all personnel. Wear protective goggles or a face shield to prevent injury to the eyes.

**WARNING**

Be careful when cleaning with steam. Steam can cause serious burns. Wear protective clothing, gloves, and eye protection. Never expose your skin to steam.

When cleaning with steam, use a hose with a minimum diameter of 19 mm (0.75 in.). Control the pressure of the steam by a valve installed at the nozzle of the hose. If a metal nozzle is used, it must be made of a material that does not make sparks. Make an electrical connection between the nozzle and the tank. Connect a ground wire to the tank to prevent static electricity.

Steam Method of Cleaning**WARNING**

Compressed air can move particles so that they cause injury to the user or to other personnel. Make sure that the path of the compressed air is away from all personnel. Wear protective goggles or a face shield to prevent injury to the eyes.

**WARNING**

Be careful when cleaning with steam. Steam can cause serious burns. Wear protective clothing, gloves, and eye protection. Never expose your skin to steam.

Use the following procedure to clean the tank with steam:

1. Remove all the parts from the tank. Install the drain plug.
2. Fill the tank 1/4 full with a solution of water and sodium bicarbonate or sodium carbonate. Mix 0.5 kg (1 lb) per 4 liter (1 gal) of water.

3. Mix the solution in the tank using air pressure. Make sure all the surfaces on the inside of the tank are flushed with the solution. Drain the tank.
4. Put steam into the tank until the tank does not have odors and the metal is hot. Steam vapors must come from all the openings.
5. Flush the inside of the tank with boiling water. Make sure all the loose material is removed from the inside of the tank.
6. Make an inspection of the inside of the tank. If it is not clean, repeat Step 4 and Step 5 and make another inspection. When making inspections, use a light that is approved for locations with flammable vapors.
7. Put plugs in all the openings in the tank. Wait 15 minutes, then remove the inlet and outlet plugs. Test a sample of the vapor with a special indicator for gas vapors. If the amount of flammable vapors is above the lower flammable limit, repeat the cleaning procedures.

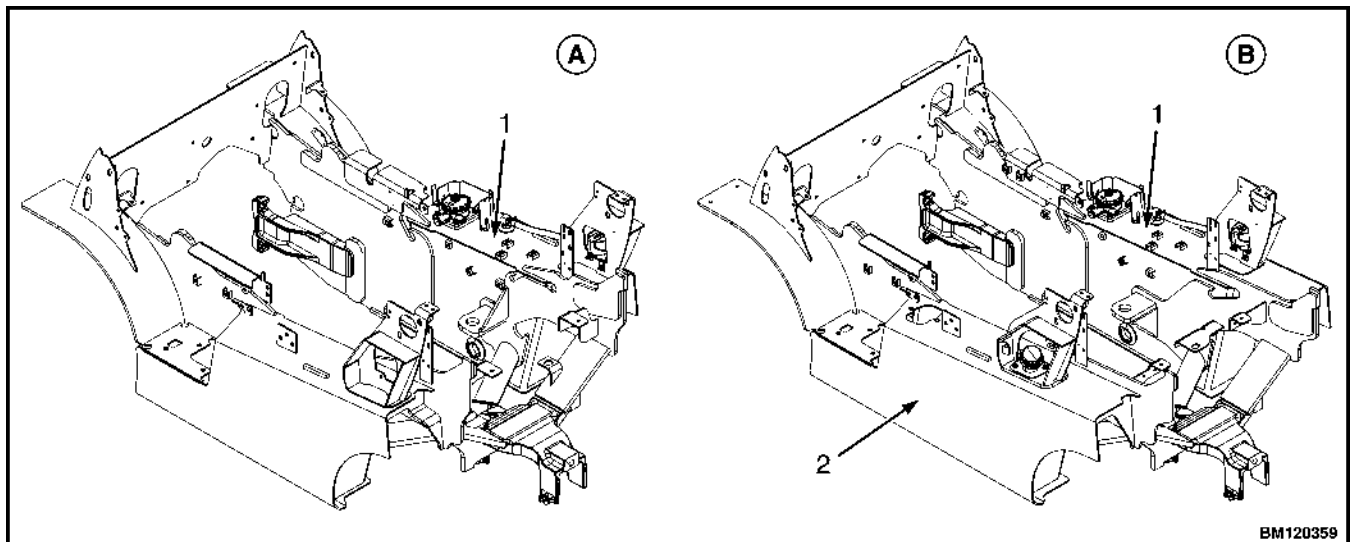
**A. FRAME FOR LPG LIFT TRUCK****B. FRAME FOR DIESEL OR DUAL FUEL LIFT TRUCK**

1. HYDRAULIC TANK

2. FUEL TANK

Figure 42. Hydraulic and Fuel Tanks

Chemical Solution Method of Cleaning



WARNING

When cleaning the tank, do not use solutions that make dangerous gases at normal temperatures or when heated. Wear eye and face protection. Protect the body from burns.



WARNING

Compressed air can move particles so that they cause injury to the user or to other personnel. Make sure that the path of the compressed air is away from all personnel. Wear protective goggles or a face shield to prevent injury to the eyes.



CAUTION

Disposal of lubricants, fluids, and chemicals must meet local environmental regulations.

If the tank cannot be cleaned with steam, use the following procedure:

1. Mix a solution of water and trisodium phosphate or a cleaning compound with an alkaline base. Follow the instructions given by the manufacturer.
2. Fill the tank with the cleaning solution. Use compressed air to mix the solution in the tank.
3. Drain the tank. Flush the inside of the tank with hot (boiling) water. Make sure all the cleaning compound is removed.
4. Make an inspection of the inside of the tank. If the tank is not clean, repeat Step 1 through Step 3. Make another inspection of the tank. When making inspections, use a light that is approved for locations with flammable vapors.
5. Check the tank for flammable vapors using special indicator for gas vapors. If the amount of flammable vapors is not below the lower flammable limit, repeat the cleaning procedures.

ADDITIONAL PREPARATIONS FOR REPAIR

If nitrogen gas or carbon dioxide gas is available, prepare the tank for welding using these gases. See the manual *Safe Practices for Welding and Cutting Con-*

tainers That Have Held Combustibles by the American Welding Society, F4.1 - 1999. If these gases are not available, another method using water can be used as follows:

1. Fill the tank with water to just below the point where the work will be done. Make sure the space above the level of the water has a vent.
2. Use acceptable welding practices to repair the tank. See the American National Standard *Safety in Welding and Cutting*, AWS Z 49.1 - 1999.

SMALL LEAKS, REPAIR

Use the following procedure to repair small leaks:

1. Use steam to clean the area around the leak. Remove all paint and dirt around the leak.
2. Apply Loctite® 290 to the leak. Follow the instructions of the manufacturer.

LARGE LEAKS, REPAIR

1. Use one of the procedures described under Clean to clean and prepare the tank for repairs.
2. Contact your dealer for lift trucks for welding instructions.
3. Use acceptable welding practices to repair the tank. See the American National Standard *Safety in Welding and Cutting*, AWS Z 49.1 - 1999.

PREPARATIONS FOR USE AFTER REPAIR

1. Add more water to the tank so that the water goes above the point of where the work was done. Check to see if there are any leaks coming from tank.
2. If there are no leaks coming from the tank, remove all the water from the tank.

Label Replacement



WARNING

Safety labels are installed on the lift truck to provide information about operation and possible hazards. It is important that all safety labels are installed on the lift truck and can be read.

DO NOT add to or modify the lift truck. Any change to the lift truck, the tires, or its equipment can change the lifting capacity. The lift truck must be rated as equipped, and the Nameplate must show the new capacity rating. Contact your dealer for a new Nameplate.



WARNING

Cleaning solvents can be flammable and toxic and can cause skin irritation. When using cleaning solvents, always follow the recommendations of the manufacturer.

Not all labels that are used on the lift trucks covered in this manual are shown in and Figure 44. See the **Parts Manual** for a complete listing of all labels used on these lift trucks and their part numbers.

See Figure 43 for lift truck models below with PSI engine

- GLC050LX (B967)
- GLP20-25LX (GLP050LX) (B974)

See Figure 44 for lift truck models below with Yanmar Diesel engine

- GDP20-25LX (GDP050LX) (B974)

If a new label must be installed, use the following procedure to install a new label.

1. Make sure the surface is dry and has no oil or grease. Do not use solvent on new paint. Clean the surface of old paint with a cleaning solvent.
2. Remove the paper from the back of the label. Do not touch the adhesive surface.
3. Carefully hold the label in the correct position above the surface. The label cannot be moved after it touches the surface. Put the label on the surface. Make sure that all air is removed from under the label, and the corners and edges are tight.

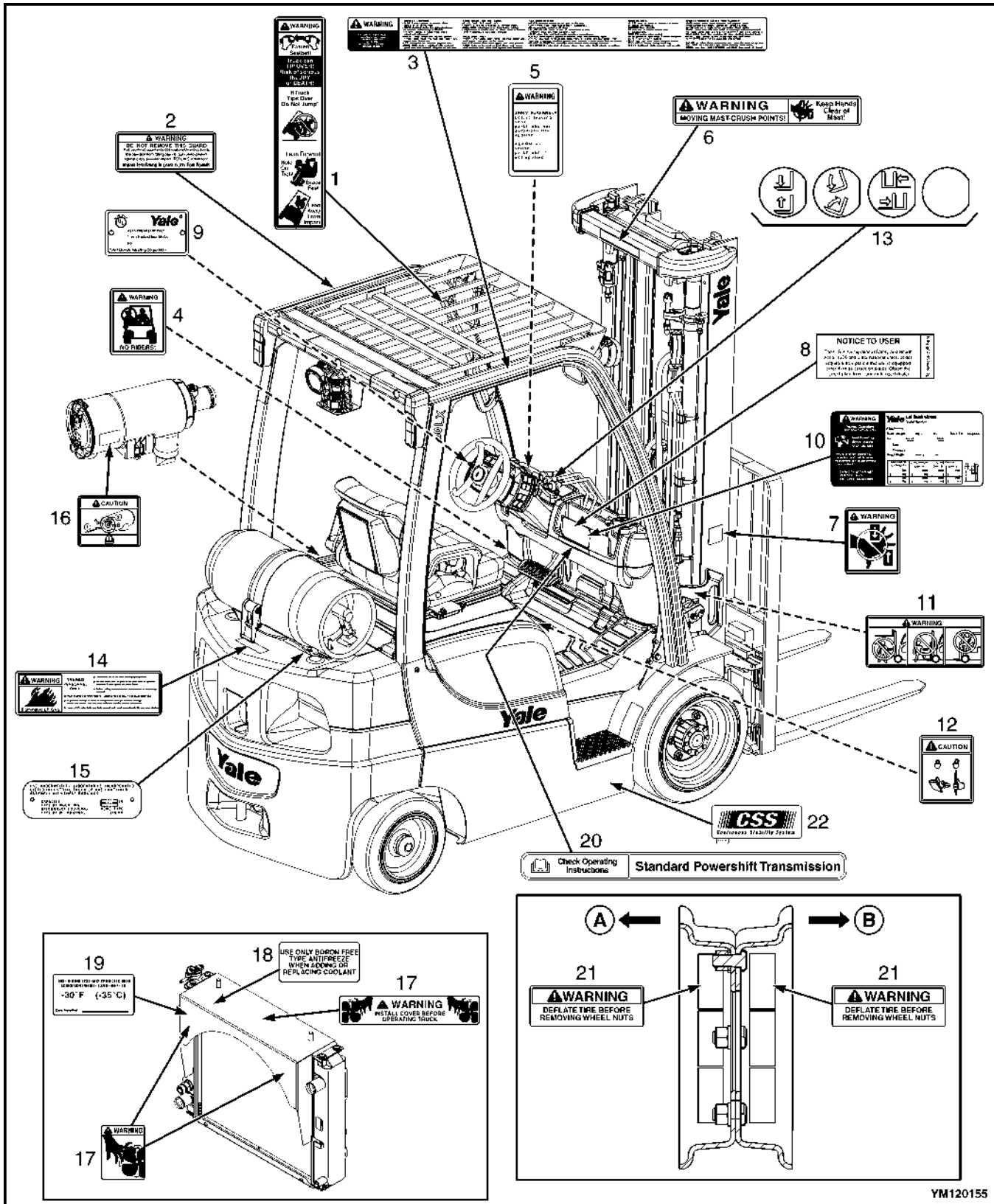

YM120155

Figure 43. Warning and Safety Labels for Lift Trucks with PSI Engine

Legend for Figure 43

1. TIP OVER WARNING
2. OVERHEAD GUARD LABEL
3. OPERATION WARNING
4. NO RIDERS
5. PARKING BRAKE WARNING LABEL
6. MASAT WARNING
7. MAST WARNING
8. NOTICE TO USER LABEL
9. UL LABEL
10. NAMEPLATE
11. NO ONE ON OR UNDER FORKS
12. LOCKING GAS SPRING
13. LIFT AND TILT LABEL
14. FLAMMABLE LP GAS
15. LPG TANK WARNING
16. AIR FILTER INSTALL CAUTION
17. FAN WARNING
18. BORON-FREE LABEL
19. ANTIFREEZE LABEL
20. TRANSMISSION LABEL (EXAMPLE ONLY)
21. SPLIT WHEEL WARNING (OPTIONAL FOR GLP/GDP20-25LX)
22. STABILITY SYSTEM LABEL*

*US TRUCKS ONLY

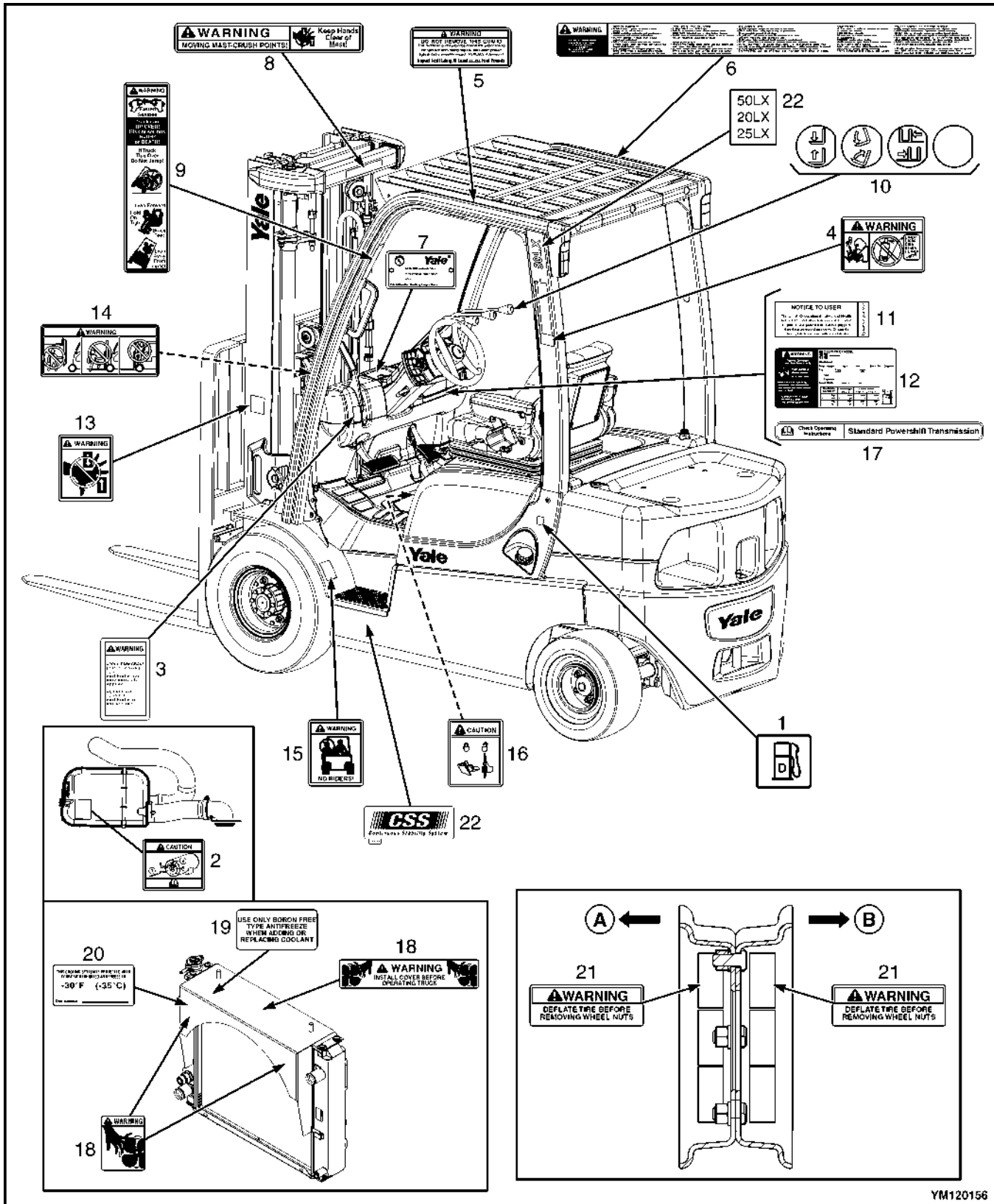

YM120156

Figure 44. Warning and Safety Labels for Lift Trucks with Yanmar Diesel Engine

Legend for Figure 44

1. FUEL LABEL (DIESEL)*
2. AIR FILTER INSTALL CAUTION
3. PARKING BRAKE WARNING LABEL
4. ETHER WARNING LABEL
5. OVERHEAD GUARD LABEL
6. OPERATION WARNING
7. UL LABEL*
8. MAST WARNING
9. TIP OVER WARNING
10. LIFT AND TILT LABEL
11. NOTICE TO USER LABEL
12. NAMEPLATE
13. PINCH POINT WARNING
14. NO ONE ON OR UNDER FORKS
15. NO RIDERS
16. LOCKING GAS SPRING
17. TRANSMISSION LABEL (EXAMPLE ONLY)
18. FAN WARNING
19. BORON-FREE LABEL
20. ANTIFREEZE LABEL
21. SPLIT WHEEL WARNING (OPTIONAL FOR GLP/GDP20-25LX)
22. STABILITY SYSTEM LABEL*

*U.S. TRUCKS ONLY

General

This section has the repair instructions for the following Yanmar diesel engines:

- **4TNE92-NMH** - 2.6L engine (Yale Part No. 580063566), used in lift truck GLP/ GDP20-35VX (GP/GLP/GDP040-070VX) (B875, C875).
- **4TNE92-NMHA** - 2.6L engine (Yale Part No. 580061270), used in lift truck GLP/ GDP16-18VX, GLP/GDP20SVX (GP/GLP/ GDP030-035VX, GP/GLP/GDP040SVX) (C810)
- **4TNE98-NMH** - 3.3L engine (Yale Part No. 580063567), used in lift truck GLP/ GDP20-35VX (GP/GLP/GDP040-070VX) (B875, C875)
- **4TNE92-NMH/1688273**
- 2.6L engine (Yale Part No. 580090036), used in lift truck GLP/GDP20-35VX (GP/GLP/ GDP040-070VX) (B875, C875).
- **4TNE98-BNMH**
- 3.3L engine (Yale Part No. 588087403), used in lift truck GLP/GDP20-35VX (GP/GLP/ GDP040-070VX) (B875, C875).
- **4TNE92-NMHA/1688253**
- 2.6L engine 2008 (Yale Part No. 580090035), used in lift truck models GLP/GDP16-18VX, GLP/GDP20SVX (GP/GLP/GDP030-035VX, GP/GLP/GDP040SVX) (C810) and GLP/ GDP20-25LX (GLP/GDP050LX) (A974)
- **4TNE94L-BSNMH**
- 3.0L engine (Yale Part No. 582023116) used in lift truck GLP/GDP20-35VX (B875, C875).

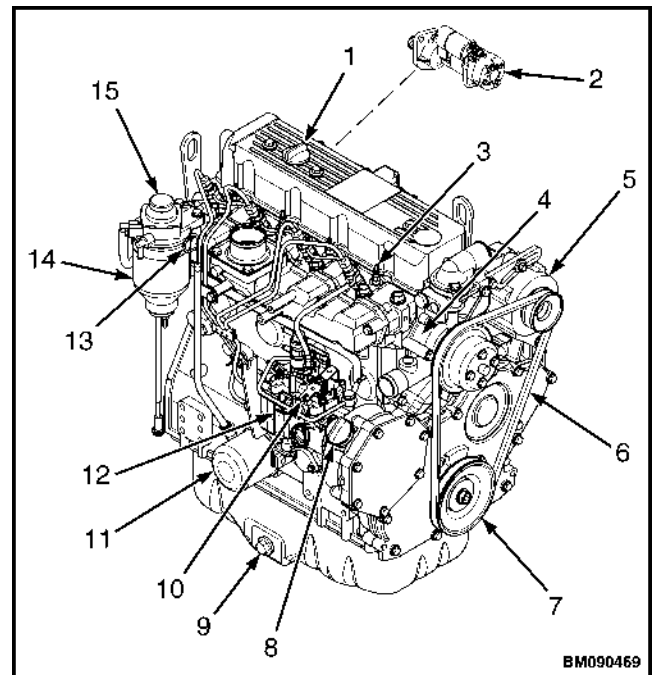

1. TOP FILLER PORT (ENGINE OIL)
2. STARTER MOTOR
3. GLOW PLUG
4. WATER PUMP
5. ALTERNATOR
6. V-BELT
7. CRANKSHAFT V-PULLEY
8. SIDE FILLER PORT (ENGINE OIL)
9. DRAIN PLUG
10. GOVERNOR LEVER
11. ENGINE OIL FILTER
12. FUEL INJECTION PUMP
13. DIPSTICK (ENGINE OIL)
14. FUEL FILTER/WATER SEPARATOR
15. FUEL PRIMING PUMP

ENGINE IDENTIFICATION

Major Engine Component Identification

Figure 1 shows where the major engine components are located.

Figure 1. Major Engine Components

Location of Labels

The typical location of the emission control information label is shown in Figure 2.

The typical location of the engine nameplate is shown in Figure 2. The engine nameplate is shown in Figure 3.

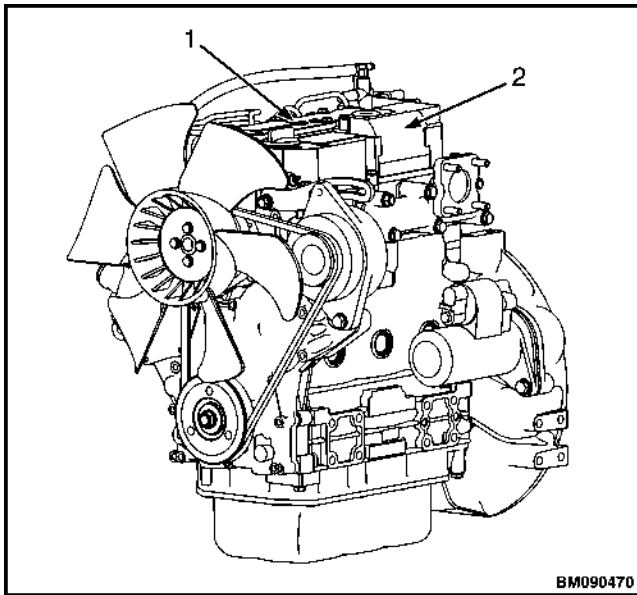

- 1. ENGINE NAMEPLATE
- 2. EMISSION CONTROL INFORMATION LABEL

Figure 2. Typical Location of Engine Labels

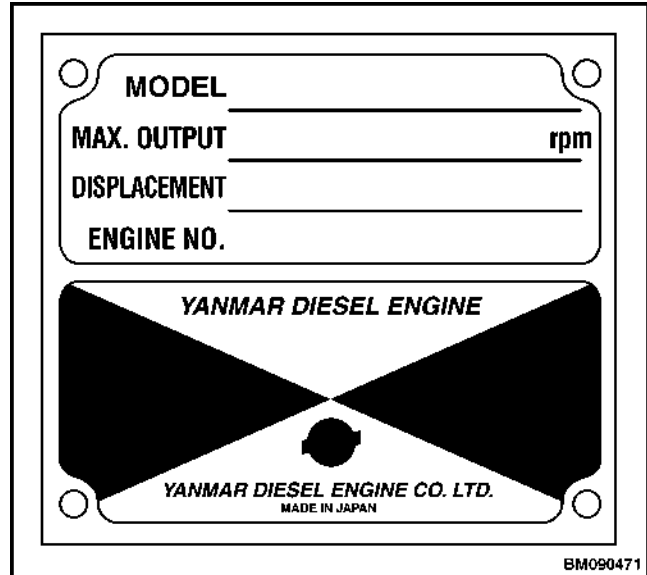

Figure 3. Engine Nameplate (Typical)

Engine Removal and Installation

The procedures to remove and install the engine are not included in this section.

See section **Frame** 0100YRM1120 for lift truck models

- GLP/GDP16VX, GLP/GDP18VX, GLP/GDP20SVX (GP/GLP/GDP030VX, GP/GLP/GDP035VX, GP/GLP/GDP040SVX) (C810)
- GLP/GDP20-35VX (GP/GLP/GDP040-070VX) (B875)

See section **Frame** 0100YRM1423 for lift truck models

- GLP/GDP20-25LX (GLP/GDP050LX) (A974)

See section **Frame** 0100YRM1672 for lift truck models

- GLP/GDP20-35VX (GP/GLP/GDP040-070VX) (C875)

Cylinder Head Assembly Repair

Refer to Figure 4 for the cylinder head components.

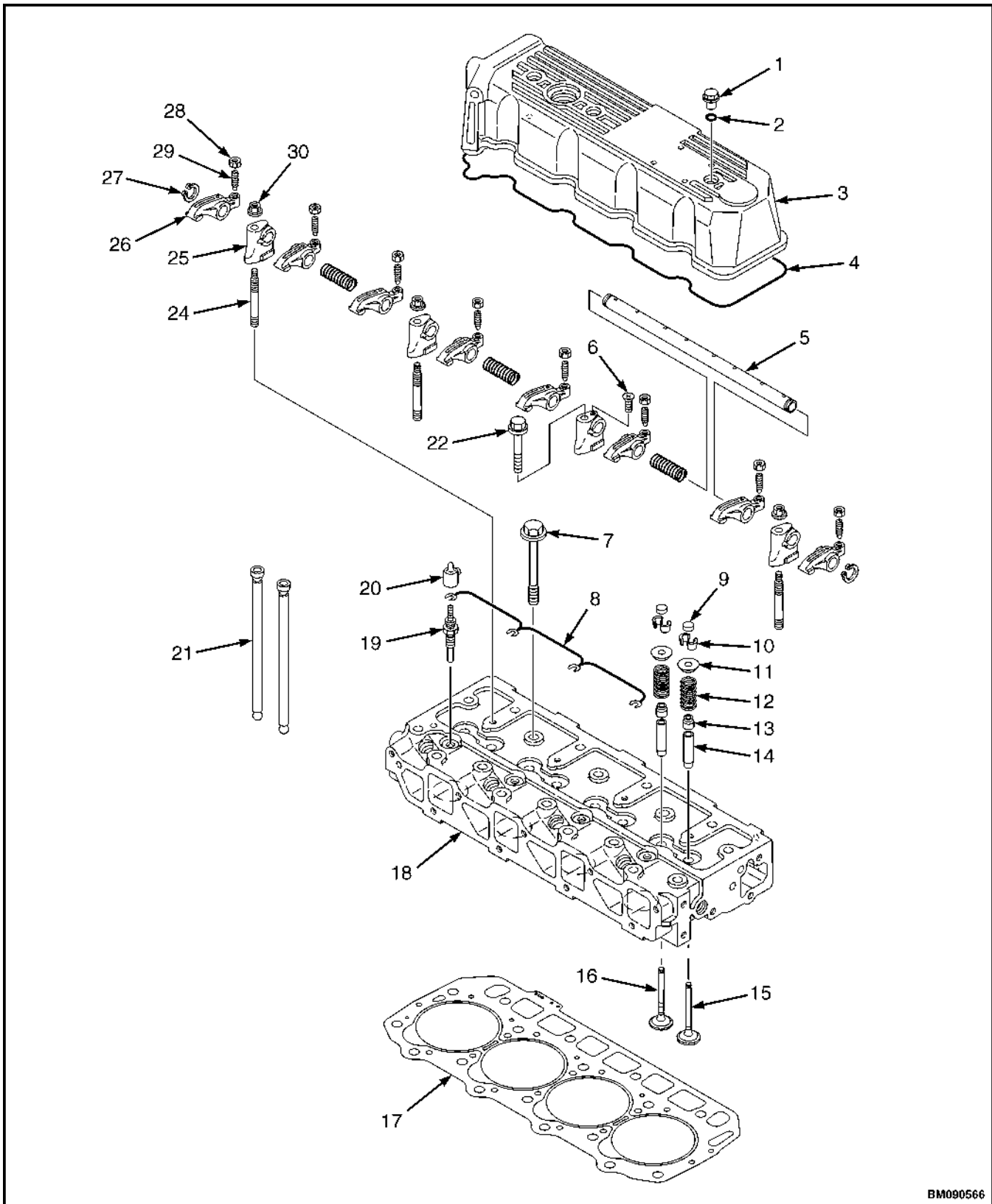

BM090566

Figure 4. Cylinder Head Components

Legend for Figure 4

- | | |
|-------------------------------------|-------------------------------------|
| 1. VALVE COVER NUT | 16. EXHAUST VALVE |
| 2. O-RING | 17. CYLINDER HEAD GASKET |
| 3. VALVE COVER | 18. CYLINDER HEAD |
| 4. VALVE COVER GASKET | 19. GLOW PLUG |
| 5. ROCKER ARM SHAFT | 20. GLOW PLUG COVER |
| 6. ROCKER ARM SHAFT RETAINING SCREW | 21. PUSH ROD |
| 7. CYLINDER HEAD BOLT | 22. SUPPORT BRACKET BOLT |
| 8. GLOW PLUG HARNESS | 23. ROCKER ARM SHAFT SPRING |
| 9. VALVE CAP | 24. SUPPORT BRACKET STUD |
| 10. VALVE KEEPERS | 25. SUPPORT BRACKET |
| 11. SPRING RETAINER | 26. ROCKER ARM |
| 12. VALVE SPRING | 27. ROCKER ARM SHAFT RETAINING RING |
| 13. VALVE STEM SEAL | 28. VALVE ADJUSTING SCREW LOCK NUT |
| 14. VALVE GUIDE | 29. VALVE ADJUSTING SCREW |
| 15. INTAKE VALVE | 30. SUPPORT BRACKET NUT |

GLOW PLUGS

Remove

1. Disconnect the negative battery cable at the battery.
2. Remove the glow plug cover from each of the glow plugs. See Figure 5.
3. Disconnect the glow plug harness from the glow plugs.
4. Remove the glow plugs from the cylinder head.

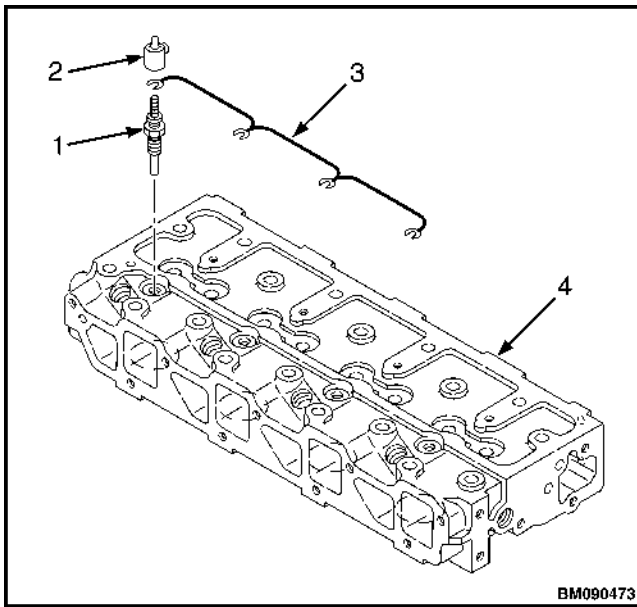

- | | |
|--------------|------------------|
| 1. GLOW PLUG | 3. WIRE HARNESS |
| 2. COVER | 4. CYLINDER HEAD |

Figure 5. Glow Plugs

Install

1. Install the glow plugs into the cylinder head.
2. Connect the glow plug harness to the glow plugs.
3. Install the glow plug covers on each glow plug.
4. Connect the negative battery cable.

VALVE COVER

Remove

1. Remove the valve cover nuts. See Figure 6.
2. Inspect the O-rings on each valve cover nut. Replace as needed.
3. Remove the valve cover.
4. Remove the valve cover gasket and discard.

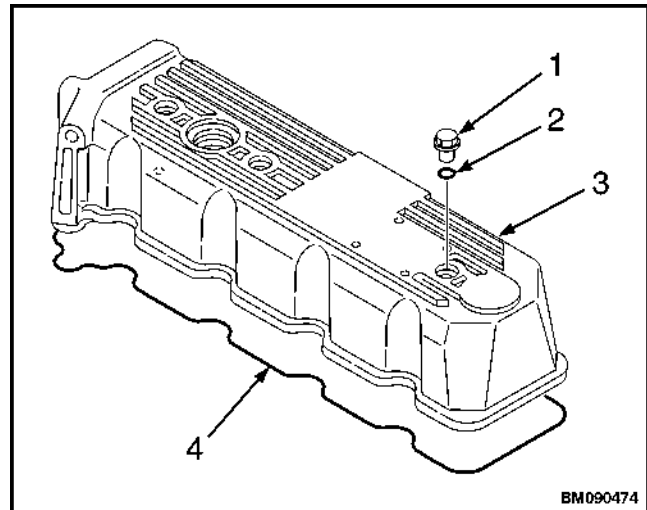

- | | |
|--------------------|----------------|
| 1. VALVE COVER NUT | 3. VALVE COVER |
| 2. O-RING | 4. GASKET |

Figure 6. Valve Cover

Clean and Inspect**WARNING**

Cleaning solvents can be flammable and toxic and can cause skin irritation. When using cleaning solvents, always follow the recommendations of the manufacturer.

**WARNING**

Compressed air can move particles so that they cause injury to the user or to other personnel. Make sure that the path of the compressed air is away from all personnel. Wear protective goggles or a face shield to prevent injury to the eyes.

**CAUTION**

Use caution not to scratch the gasket mating surfaces when cleaning the valve cover and cylinder head.

Carefully remove all gasket residue from the valve cover and cylinder head.

Clean the valve cover in cleaning solvent. Dry the valve cover with compressed air. Inspect for wear, cracks, and any other damage. If necessary, replace valve cover.

Install

1. Lightly grease the new valve cover gasket.
2. Place the new valve cover gasket in the groove of the valve cover.
3. Place the valve cover in position on the cylinder head.
4. Verify that the O-rings are installed on the valve cover nuts.

5. Install and tighten the valve cover nuts. Refer to Standard Torque Specifications.

ROCKER ARM ASSEMBLY**Remove**

1. Remove the valve cover. See Valve CoverRemove.
2. Remove the bolt and locking nuts that retain the rocker arm assembly support brackets to the cylinder head. See Figure 7.
3. Lift the rocker arm shaft assembly from the cylinder head.

NOTE: Mark the push rods so they can be reinstalled in original location during reassembly.

4. Remove the push rods from the cylinder head.

Disassemble

1. Remove the rocker arm shaft retaining screw from the support bracket that secures the rocker arm shaft. See Figure 7.
2. Remove the retaining rings from the ends of the rocker arm shaft.

NOTE: Mark the rocker arms so they can be reinstalled in original location during reassembly.

NOTE: The rocker arm shaft fits tightly in the rocker arm support brackets. Clamp the support bracket in a padded vise and twist and pull the rocker arm shaft to remove the shaft.

3. Slide the rocker arm shaft out of the rocker arm support brackets, springs, and rocker arms.
4. If necessary, remove the valve adjusting screw and lock nut from the rocker arms.

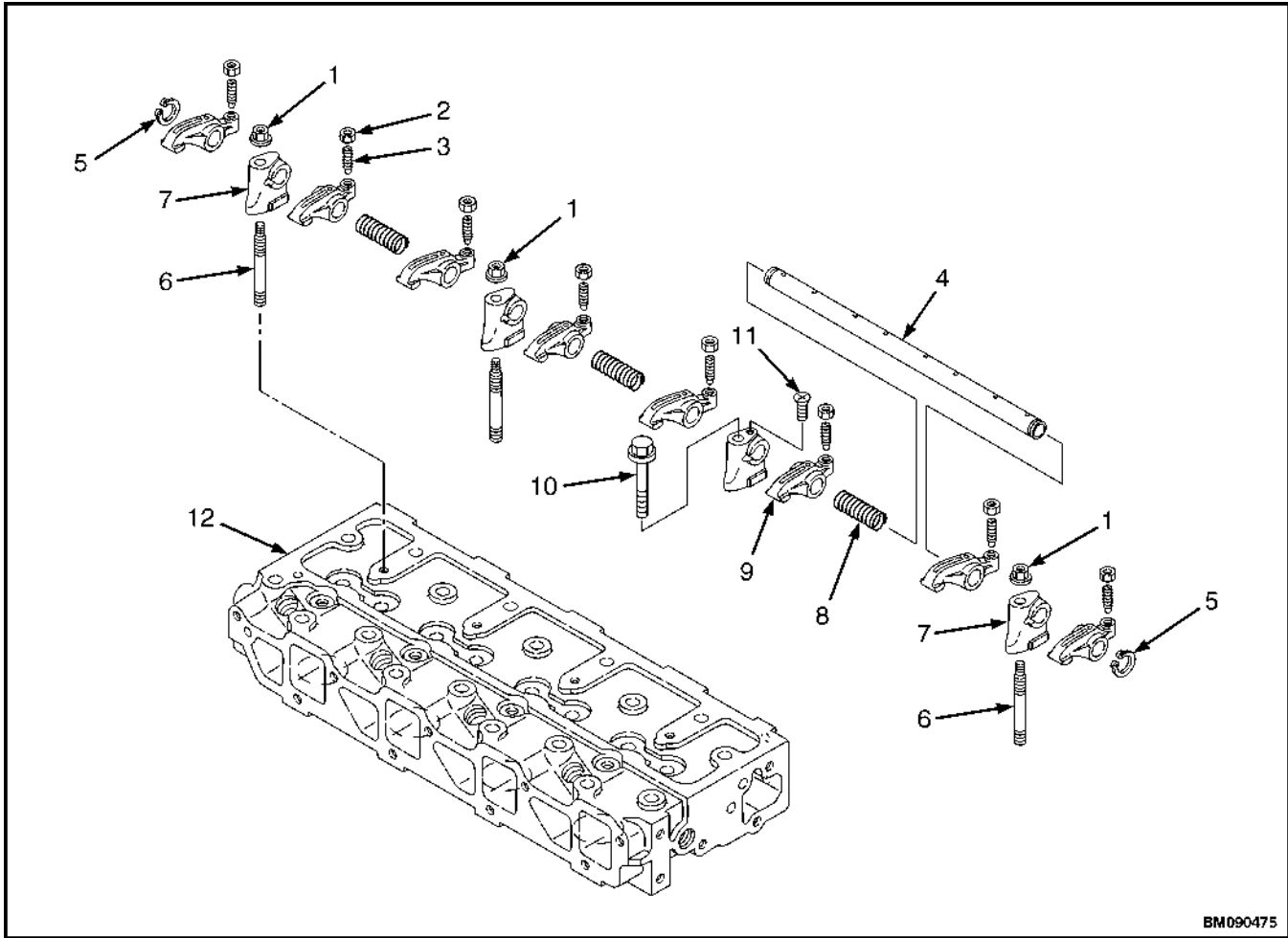

BM090475

- | | |
|------------------------------------|--------------------------------------|
| 1. SUPPORT BRACKET NUT | 7. SUPPORT BRACKET |
| 2. VALVE ADJUSTING SCREW LOCK NUT | 8. ROCKER ARM SHAFT SPRING |
| 3. VALVE ADJUSTING SCREW | 9. ROCKER ARM |
| 4. ROCKER ARM SHAFT | 10. SUPPORT BRACKET BOLT |
| 5. ROCKER ARM SHAFT RETAINING RING | 11. ROCKER ARM SHAFT RETAINING SCREW |
| 6. SUPPORT BRACKET STUD | 12. CYLINDER HEAD |

Figure 7. Rocker Arm Assembly

Clean and Inspect**⚠ WARNING**

Cleaning solvents can be flammable and toxic and can cause skin irritation. When using cleaning solvents, always follow the recommendations of the manufacturer.

⚠ WARNING

Compressed air can move particles so that they cause injury to the user or to other personnel. Make sure that the path of the compressed air is away from all personnel. Wear protective goggles or a face shield to prevent injury to the eyes.

Clean all parts in cleaning solvent. Dry the parts with compressed air. Inspect for wear, cracks, and any other damage. Replace all parts as needed.

Push Rods

1. Place the push rods on a flat inspection block.
2. Roll the push rods until a gap can be observed between a portion of the push rod and the surface of the inspection block.
3. Use a feeler gauge to measure the gap. Refer to the Engine Specifications for the service limit. See Figure 8.

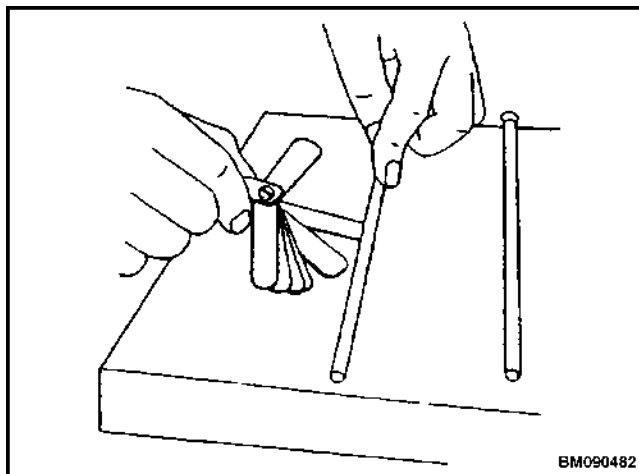

Figure 8. Push Rod Inspection

Rocker Arm Assembly**Rocker Arm and Support Bracket Inside Diameter**

- Use a test indicator and micrometer to determine if the inside diameter of all the rocker arm support brackets and rocker arms are within limits. Refer to the Engine Specifications for the service limit. See Figure 9.

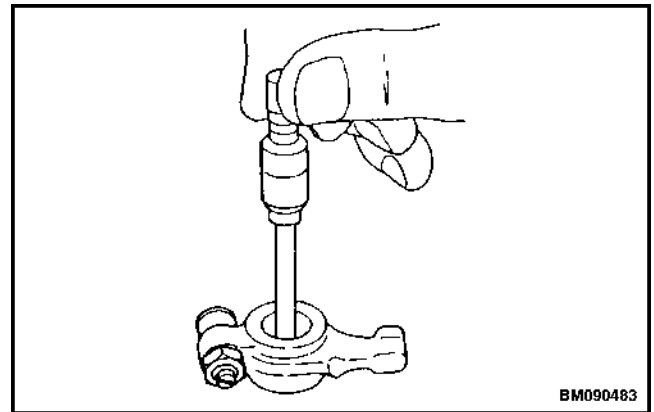

Figure 9. Rocker Arm Inside Diameter

Shaft Outside Diameter - Use a micrometer to measure the rocker arm shaft outside diameter. Refer to the Engine Specifications for the service limit. See Figure 10.

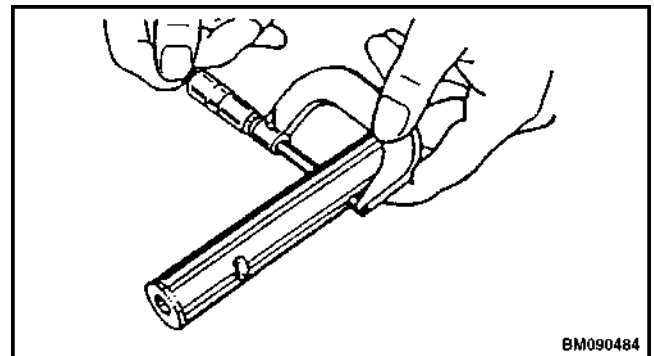

Figure 10. Rocker Arm Shaft Outside Diameter

Assemble

NOTE: The rocker arm shaft fits tightly in the rocker arm support brackets. Clamp the rocker arm shaft in a padded vise and twist and push the support brackets onto the rocker arm shaft.

NOTE: To properly align the rocker arm shaft with the support brackets, first install the rocker arm shaft support bracket with the hole for the shaft alignment screw. Align the hole in the rocker arm shaft and the hole in the support bracket. Install the alignment screw. See Figure 7.

1. Lubricate the rocker arm shaft. Slide the rocker arm support brackets, springs, and rocker arms onto the shaft.
2. Position the rocker arm assembly on a flat surface. Install the retaining rings onto the ends of the rocker arm shaft. See Figure 7.
3. If removed, install the valve adjusting screws and lock nuts.

Install

1. Install the push rods.
2. Place the rocker arm assembly in position on the cylinder head.
3. Install and hand tighten the rocker arm shaft retaining bolt and nuts.
4. Align the push rods with their respective rocker arms.
5. Tighten the rocker arm shaft retaining bolt and nuts.
6. Tighten the rocker arm shaft alignment screw.
7. Adjust the valve lash. See Valve Clearance Adjustments.
8. Install the valve cover. See Valve CoverInstall.

VALVE CLEARANCE ADJUSTMENTS

NOTE: Make measurements and adjustments while the engine is cold.

NOTE: The cylinder to be adjusted first does not have to be the number one cylinder. Select and adjust the cylinder where the piston is the nearest to top dead center (TDC) after rotating and make the adjustment for the other cylinders in the order of the ignition by turning the crankshaft 180 degrees each time.

1. Remove the valve cover. See Valve CoverRemove.

NOTE: The number one piston position is on the flywheel end of the engine, opposite side of the radiator, and the ignition order is 1 - 3 - 4 - 2 at 180 degree intervals.

NOTE: Since the intake and exhaust valve rocker arms are operated the same and there is a clearance between rocker arm and valve generally at top dead center, the position can be checked by means of the play when the arm head is held with a hand. Also, see that the crankshaft pulley top mark is positioned at zero on the timing scale. If there is no valve clearance, inspection in the disassembled state is necessary since the valve seat may be worn abnormally.

2. Rotate the crankshaft clockwise, as seen from the radiator side, to bring the number one piston to top dead center (TDC) while watching the rocker arm motion, timing scale, and top mark position of the crankshaft pulley. (Position where both the intake and exhaust valves are closed.)
3. Insert a feeler gauge between the rocker arm and valve cap. See Figure 11. Record the measured valve clearance. The valve clearance should be between 0.15 to 0.25 mm (0.006 to 0.010 in.).

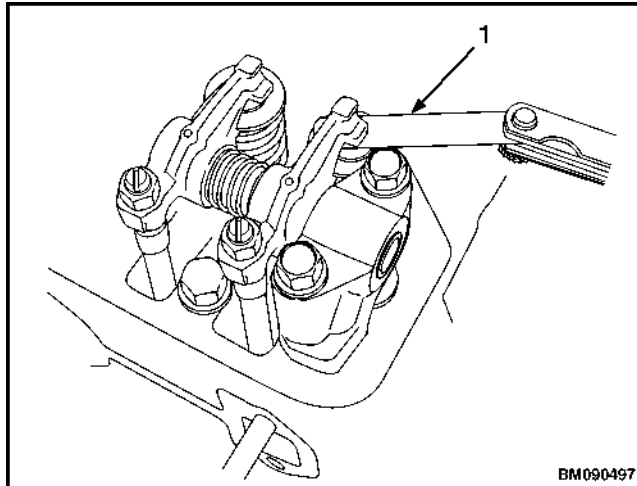

1. FEELER GAUGE

Figure 11. Valve Clearance Measurement

4. If adjustment is needed, loosen the valve adjusting screw lock nut and valve adjusting screw on the rocker arm (see Figure 12) and check the valve for any inclination of valve cap, entrance of dirt, or wear. See Figure 13.

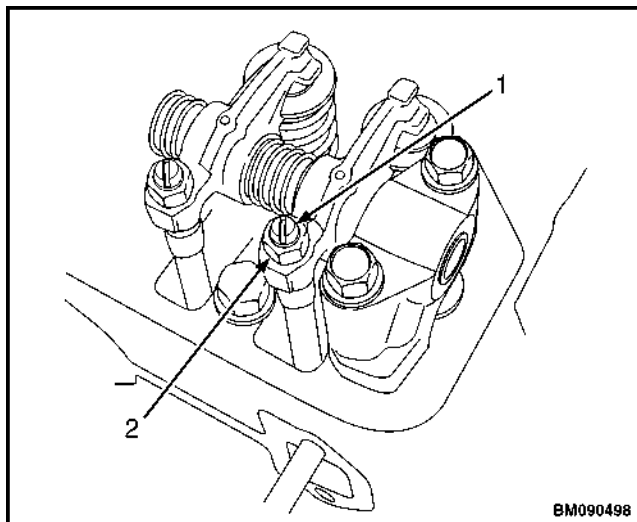

1. VALVE ADJUSTING SCREW
2. VALVE ADJUSTING SCREW LOCK NUT

Figure 12. Valve Clearance Adjustment

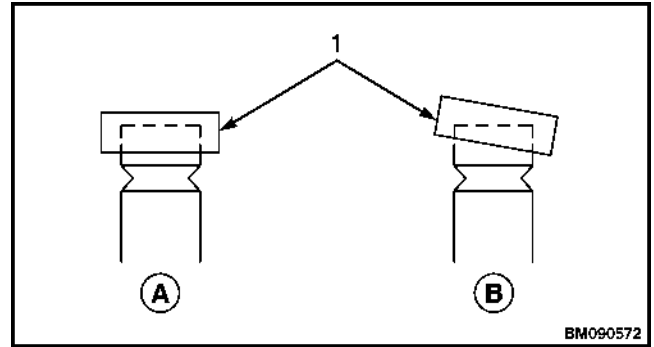

- A. NORMAL
- B. ABNORMAL

1. VALVE CAP

Figure 13. Valve Cap Check

NOTE: There is a tendency for the clearance to decrease slightly when the lock nut is tightened. It is suggested that you make the clearance adjustment slightly on the loose side before tightening the lock nut.

5. Insert a 0.2 mm (0.008 in.) feeler gauge between the rocker arm and valve cap and adjust the clearance so there is a slight drag on the feeler gauge when sliding it between the rocker arm and valve cap. Tighten the valve adjusting screw lock nut and recheck the clearance. The valve clearance should be between 0.15 to 0.25 mm (0.006 to 0.010 in.).
6. Apply clean engine oil to the contact surface between the adjusting screw and push rod.
7. Turn the crankshaft 180 degrees and make the measurement and adjustment for the number three cylinder. Then turn the crankshaft 180 degrees and make the measurement and adjustment for the number four cylinder. Then turn the crankshaft 180 degrees and make the measurement and adjustment for the number 2 cylinder.
8. Install the valve cover. See Valve Cover Install.

CYLINDER HEAD ASSEMBLY

Remove

1. Disconnect the negative battery cable at the battery.
2. Remove the alternator. See Electrical Equipment Repair.
3. Remove the water pump. See Cooling System Repair.
4. Disconnect the air intake hose from the intake manifold.
5. Remove the glow plugs. See Glow Plugs Remove.
6. Remove the fuel injectors and high pressure lines. See Fuel System Repair.
7. If equipped, remove the pull actuator and mounting bracket. See Fuel System Repair.
8. Disconnect the electrical connector for the fuel filter sensor.
9. Tag and disconnect the fuel hoses from the fuel filter.
10. Remove the bolts retaining the fuel filter housing assembly to the intake manifold and remove the fuel filter housing assembly. See Figure 14.

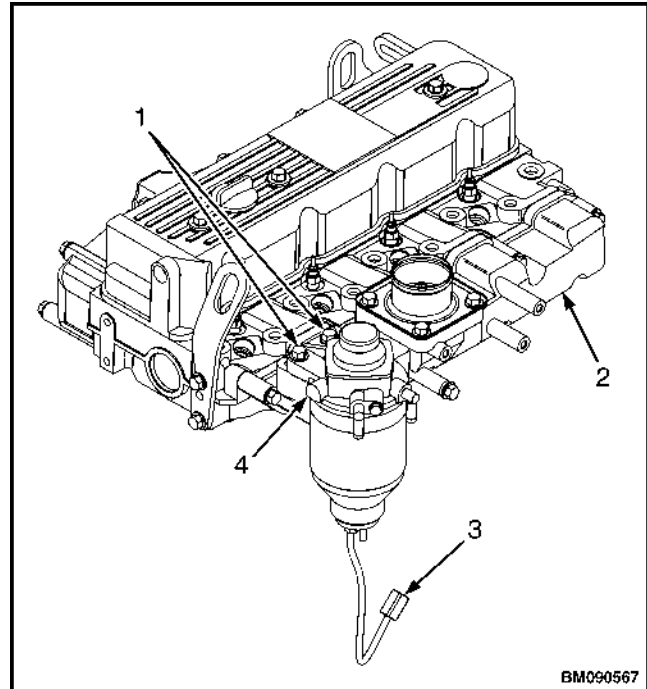

1. BOLTS
2. INTAKE MANIFOLD
3. FUEL SENSOR ELECTRICAL CONNECTOR
4. FUEL FILTER HOUSING ASSEMBLY

Figure 14. Fuel Filter Housing Assembly

11. Remove the bolts retaining the intake manifold to the cylinder head and remove the intake manifold and gasket. Discard gasket. See Figure 15.

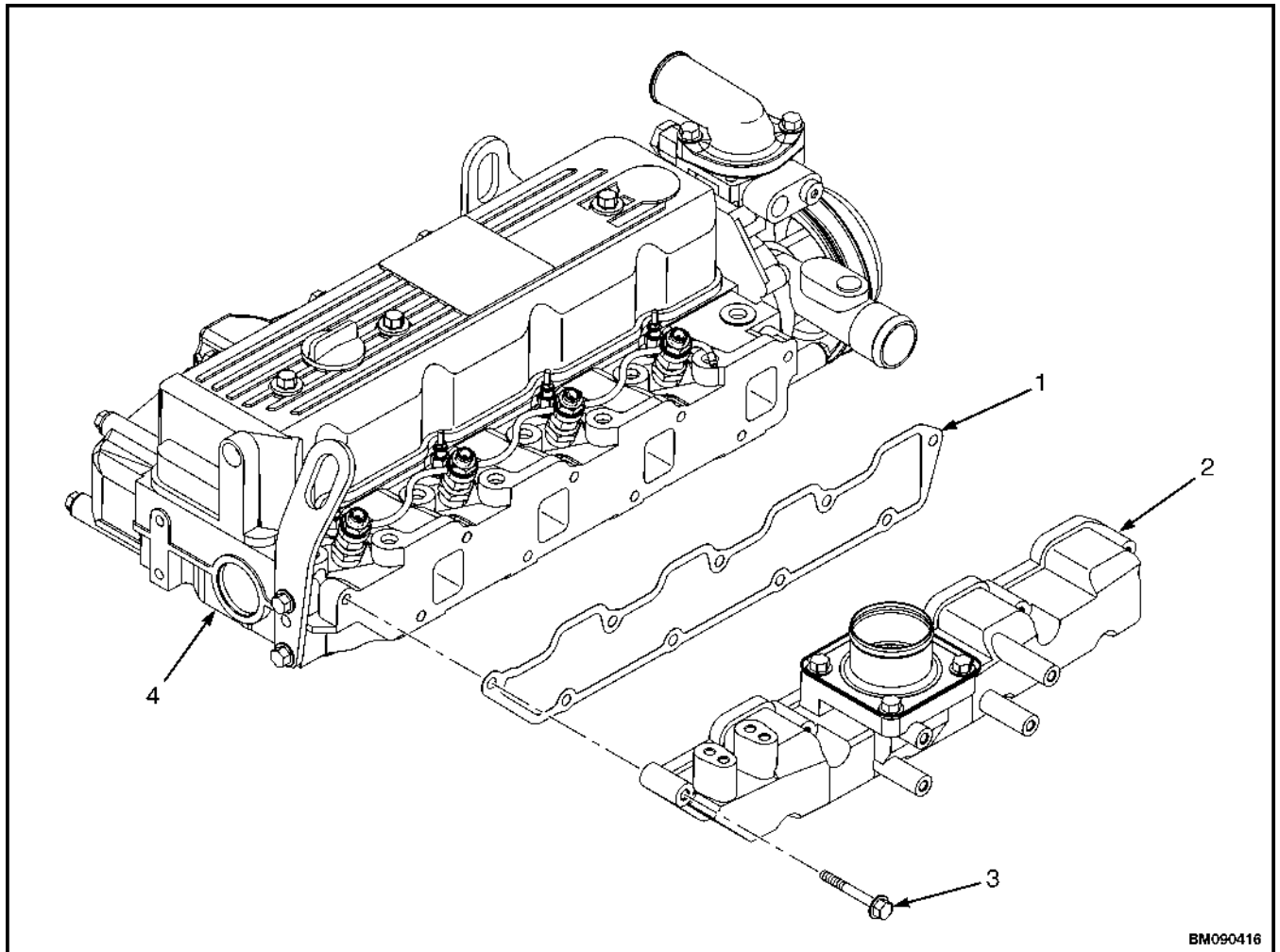

BM090416

1. GASKET
2. INTAKE MANIFOLD

3. BOLT
4. CYLINDER HEAD

Figure 15. Intake Manifold

12. Remove the nuts retaining the exhaust pipe to the exhaust manifold and disconnect the exhaust pipe from the exhaust manifold.

13. Remove the bolts retaining the exhaust manifold to the cylinder head and remove the exhaust manifold and gasket. Discard gasket. See Figure 16.

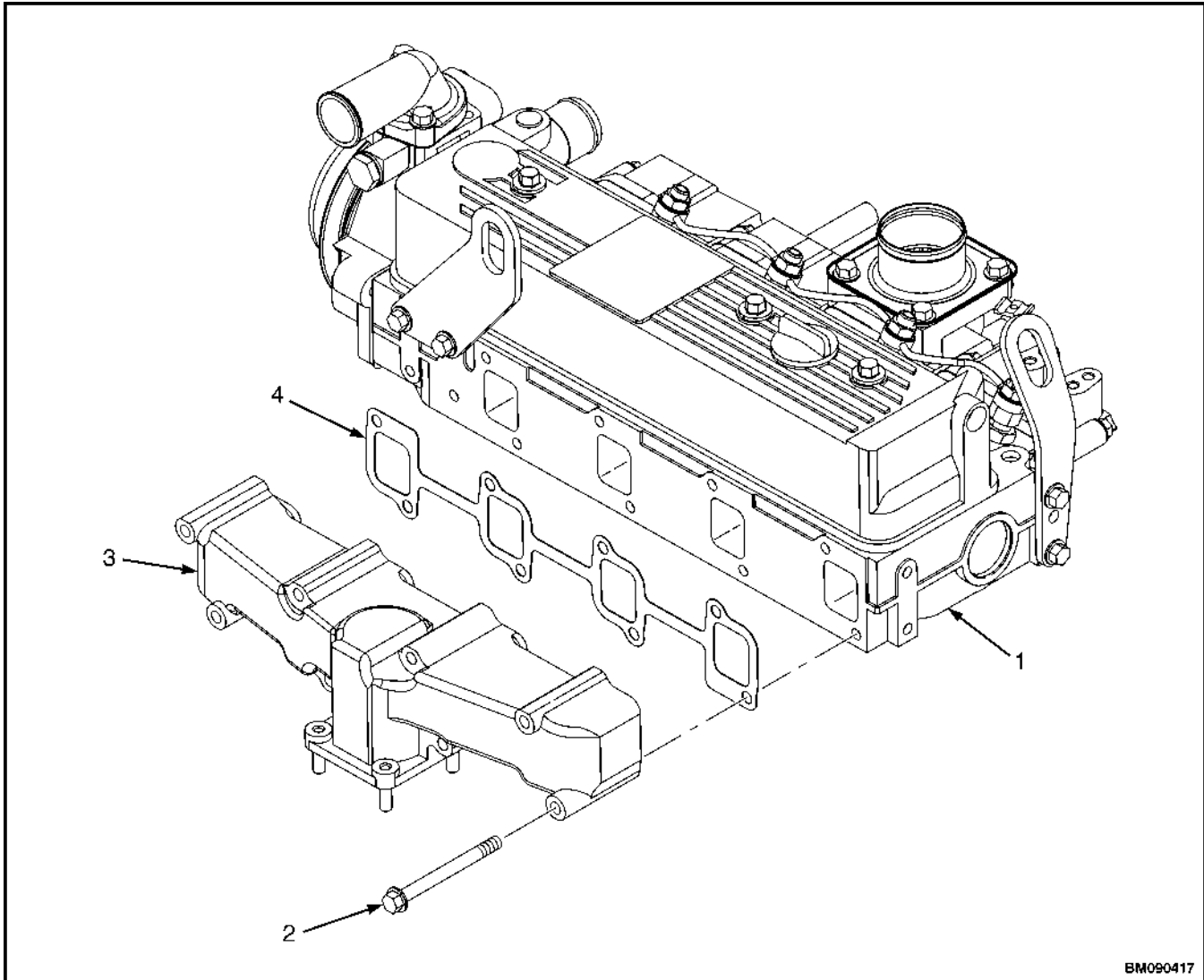

BM090417

1. CYLINDER HEAD
2. BOLT

3. EXHAUST MANIFOLD
4. GASKET

Figure 16. Exhaust Manifold

14. Remove the valve cover. See Valve Cover Remove.
15. Remove the rocker arm assembly. See Rocker Arm Assembly Remove.
16. Loosen the cylinder head bolts following the sequence shown in Figure 17.

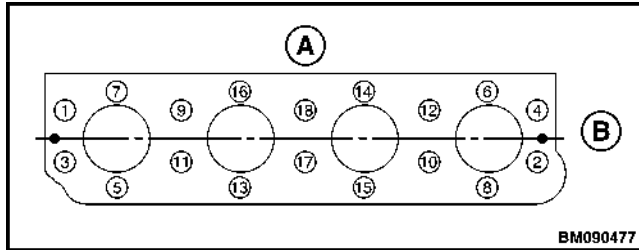

A. CAMSHAFT SIDE B. FAN SIDE

Figure 17. Cylinder Head Bolt Loosening Sequence

17. Remove the cylinder head bolts. See Figure 18.
18. Lift the cylinder head away from the cylinder block. Place the cylinder head on a work bench to prevent damage to the combustion chamber.
19. Remove the cylinder head gasket and discard.

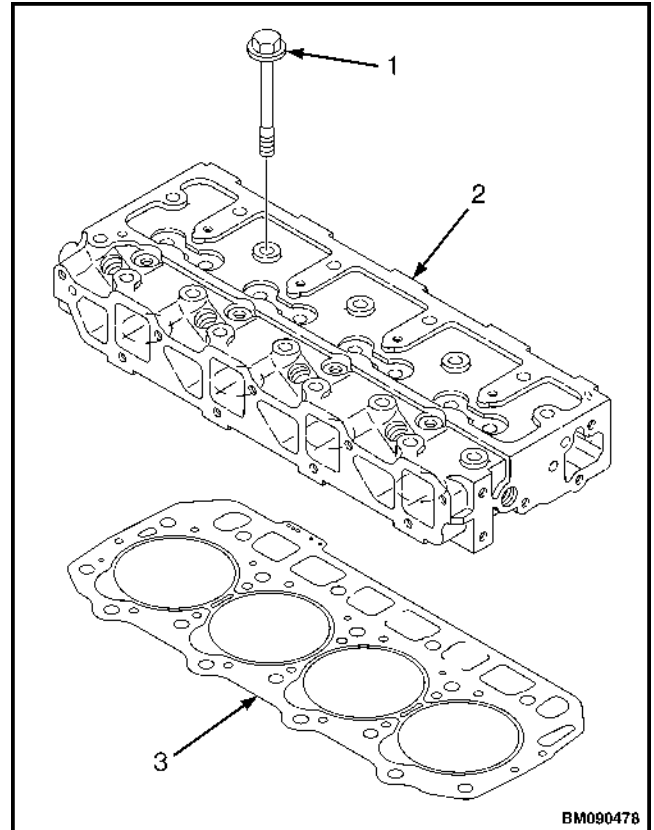

1. BOLT
2. CYLINDER HEAD
3. GASKET

Figure 18. Cylinder Head and Gasket

Disassemble

Valves and Valve Springs, Remove

1. Using a valve spring compressor tool, compress one of the valve springs. See Figure 19.

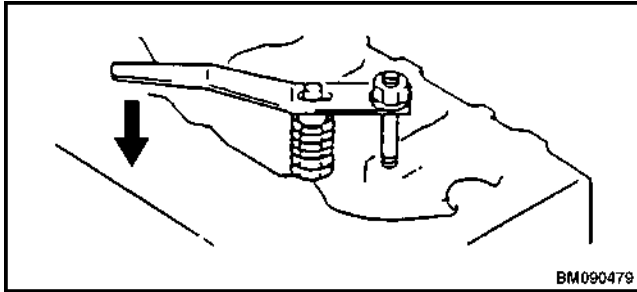
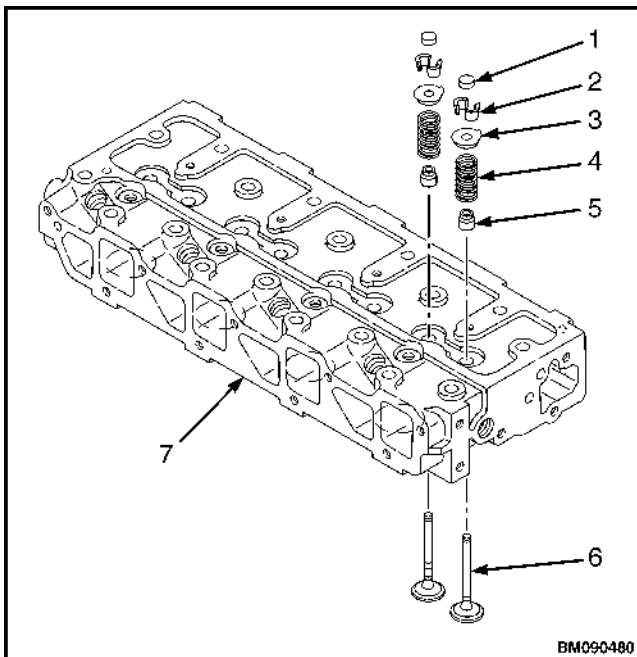

Figure 19. Valve Spring Compressor

2. Remove the valve keepers and the valve cap from the end of the valve. See Figure 20.



- | | |
|--------------------|--------------------|
| 1. VALVE CAP | 5. VALVE STEM SEAL |
| 2. VALVE KEEPERS | 6. VALVES |
| 3. SPRING RETAINER | 7. CYLINDER HEAD |
| 4. SPRING | |

Figure 20. Valves and Valve Springs

3. Slowly release the tension on the valve spring.
4. Remove the spring retainer, valve spring, and valve stem seal.
5. Repeat this procedure until all intake and exhaust valve springs and valve stem seals are removed.

NOTE: If existing valves are going to be reinstalled in the cylinder head, mark the valves so they can be installed in their original location.

6. Turn the cylinder head so the exhaust port side faces down. Remove the intake and exhaust valves from the cylinder head.

Valve Guides, Remove

Using a drift pin and hammer, drive the valve guides out of the cylinder head. See Figure 21.

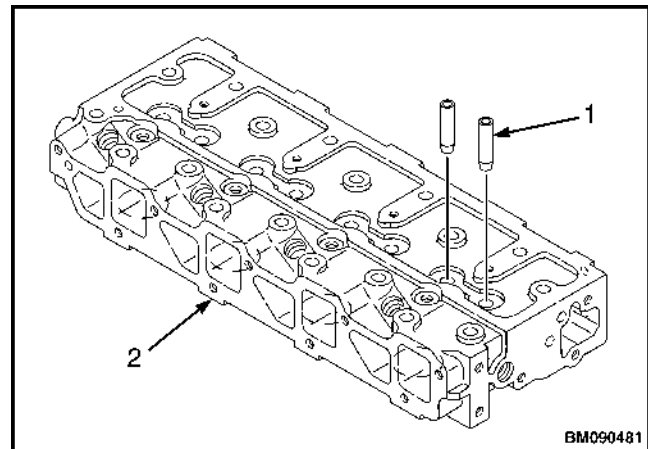

- | | |
|----------------|------------------|
| 1. VALVE GUIDE | 2. CYLINDER HEAD |
|----------------|------------------|

Figure 21. Valve Guides

**Thank you very much
for your reading.**

Please Click Here

**Then Get More
Information.**