



**YANMAR**

**OPERATION & MAINTENANCE  
MANUAL**

**EXCAVATOR**

**ViO<sub>45</sub>-5B**

**ViO<sub>55</sub>-5B**

**(US)**

ViO45-5B : S/N 53001 & Above

ViO55-5B : S/N 53001 & Above

# SAFETY

## **WARNING**

Never attempt to operate or service this Excavator until you have first read and understood all of the applicable Safety Instructions that are set forth in this Manual.

The failure to comply with all relevant Safety Instructions could result in bodily injury.

## 7. Basic Precautions

**⚠ WARNING** These instructions should be strictly followed for the safety of you, others and your machine.

### Follow safety rules at your workplace

- The operation and servicing of this machine is restricted to qualified persons.
- When operating or servicing the machine, follow all the safety rules, precautions and procedures.
- Any work performed by a team or with a signal person should be conducted in accordance with signals agreed on beforehand.

### Install safety devices

- Make sure that all guards and covers are installed in their correct position. If any of them are damaged, repair them immediately.
- The proper use of all safety devices, such as lock lever, should be well understood by the machine operator.
- Never remove the safety devices. Always make sure that they operate properly.  
**For lock lever, refer to Section "13-3. Control levers and pedals".**
- Incorrect operation of the safety devices could cause serious bodily injury.

### Wear proper clothing and safety items

- Do not wear loose clothing or jewelry that can be caught on the control levers and other machine parts. Also avoid wearing working clothes stained with oil as they can ignite.
  - Be sure to wear a helmet, safety goggles, safety shoes, a mask, gloves and other protective items, as appropriate.
- Take particular precautions when generating metal debris, when striking metal objects with a hammer or when cleaning components with compressed air.

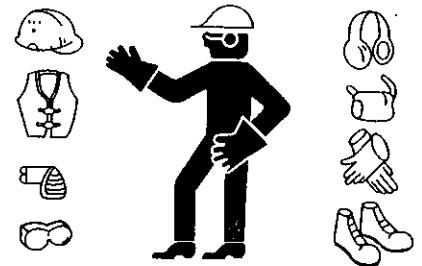

000278-00X

Also make sure there are no persons near the machine.

**For driving the pins, refer to Section "14-22. Replacing the bucket without the quick coupler"**  
**For cleaning the elements, refer to Section "27-2. Nonperiodic services".**

### Alcohol

- Never operate the machine while you are under the influence of alcohol or when you are ill or feel unwell as this results in accidents.

**Avoid unauthorized modifications**

- Modifications not recommended by YANMAR may cause safety hazards.
- When you wish to modify your machine, contact your dealer. The implementation of unauthorized modifications or the use of unauthorized attachments could result in bodily injury, since those actions would also violate, the terms of YANMAR's Warranty, it would be voided

**Always lock up your machine when leaving the operator's seat**

- When leaving the operator's seat, be sure to place the lock lever in the lock position, to prevent accidental machine movement which could result in bodily injury.
- When you leave the machine:
  - (1) Lower the bucket to the ground.
  - (2) Place the lock lever in the lock position.
  - (3) Stop the engine.
  - (4) Set all the locks in to the lock position.
  - (5) Be sure to take the key out of the starter switch.

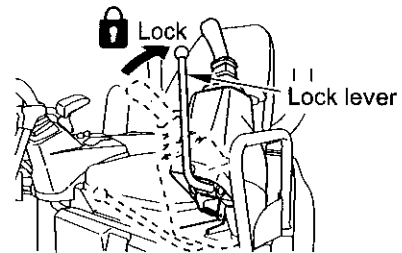

(Left side) 008999-00B

**For information on parking the machine, refer to Section "14-15. Parking the machine".**

**Use handrails and steps when getting on and off**

- Do not jump on or off the machine. Never get on or off a machine in motion as it may result in bodily injury.
  - When getting on and off the machine, face the machine and use the handrails and steps.
  - Do not use control levers as handrails.
  - Make sure that you maintain three point contact with the handrails or the steps.
  - If the handrails and the steps are soiled with oil or dirt, clean them off immediately.
- Repair any damaged parts and retighten any loose bolts.

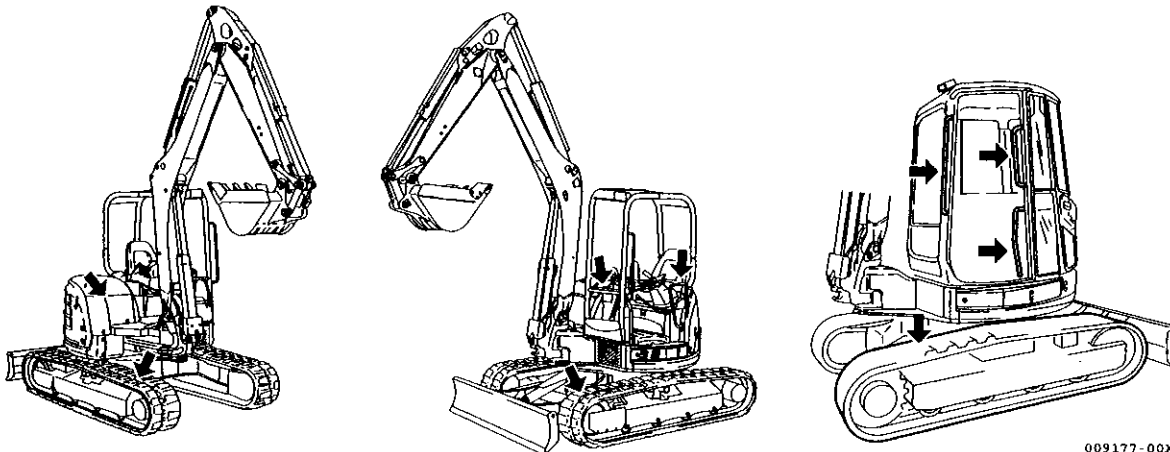

009177-00X

## 7. Basic Precautions

**⚠ WARNING** These instructions should be strictly followed for the safety of you, others and your machine.

### Keep fuel and oil away from sources of ignition

- Open flames can ignite fuel, oil, hydraulic oil or antifreeze solutions, which are flammable and dangerous. Special attention must be paid to the following matters.
- Keep flammable materials away from lighted cigarettes or matches, or any other sources of ignition.
- Never refuel while the engine is running. Smoking during refueling must be strictly prohibited.
- Firmly tighten the caps on the fuel and oil tanks.
- Store fuel and oil in a cool and well-ventilated place where they are not subjected to direct sunlight.
- Fuel and oil must be stored in a place which meets all applicable safety regulations. Unauthorized persons should not be allowed entry.

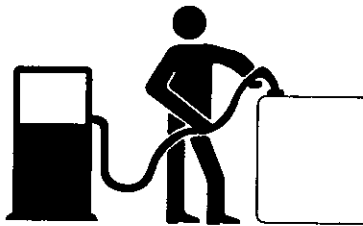

000281-00X

### Avoid removing filler caps while temperatures are high

- The engine coolant, engine oil and hydraulic oil are hot and under pressure immediately after the machine stops operation. Removing caps, draining coolant or oil, or replacing a filter at such a time may cause burns. Allow temperatures to cool down and follow the procedures in this manual.
- When removing the radiator cap, stop the engine and allow the coolant to cool down, then turn the cap slowly to relieve all pressures.
- Before removing the cap from the hydraulic oil tank, stop the engine and turn the cap slowly to relieve all pressure to prevent oil from spouting out.



000282-00X

### Avoid harmful asbestos dust

- Air containing asbestos dust is carcinogenic and is hazardous to humans. Inhalation of the air may cause lung cancer. When handling materials that may contain asbestos, keep in mind that:
  - Compressed air must not be used for cleaning.
  - Water must be used to clean the machine to prevent asbestos from scattering in the air.
  - You must work on the windward side when operating the machine in a place where there may be asbestos dust.
  - You should wear breathing apparatus as necessary.



000283-00X

### Prevent crush injuries by the implements

- Keep hands, arms and all other parts of your body away from all the moving parts, particularly between the implements and the machine and between the hydraulic cylinder and the implements, as pinch points are created in those areas.



000284-00X

### Keep a fire extinguisher and first aid kit handy

- The workplace must be provided with a fire extinguisher. Read instructions on the label to familiarize yourself with how to use it.
- Keep a first aid kit in a prescribed place.
- Advise what to do in the event of fire or accidents.
- Indicate who to contact in an emergency and keep their telephone number in a prominent place.

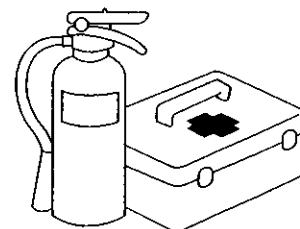

000285-00X

### Precautions for installing optional parts and attachments

- When installing or using optional attachments, read the operating instructions for the attachments and the Manual Sections relating to the installation of attachments.
- Use only attachments authorized by YANMAR. The use of unauthorized attachments may affect not only the safety of the machine but also the proper operation and life of the machine.
- The use of unauthorized attachments would also violate the terms of YANMAR's Warranty, so that it would be voided.

### Caution for cabin glass

- If the glass of the cabin should be broken by accident, it is very dangerous since the operator's body might contact the implement directly. Immediately stop working to replace the broken glass with a new one.

## 8. Operating Precautions

**⚠ WARNING** These instructions should be strictly followed for the safety of you, others and your machine.

### 8-1. Precautions before starting the engine

#### Ensure the safety of your workplace

- Before starting the machine, check to see if there are any hazards in your working area.
- Examine the terrain and soil, and decide the best way to do the work.
- When working on the street, provide a signal person or fence for the safety of vehicles and pedestrians.
- If there are underground utilities at the work site, such as water pipes, gas pipes, high-voltage conduits or others, contact the responsible companies to locate them exactly, so as not to damage them.
- Before operating the machine in water, or crossing a creek, confirm the condition of the submerged ground, the water depth and the water flow speed, and make sure that the depth is within the allowable level.

**For allowable water depth, refer to Section "14-10. Precautions for working".**

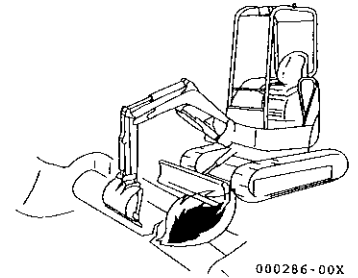

#### Prevent fire

- Wood chips, dead leaves, trash and other flammable materials in proximity to the engine are hazardous as they may cause fire. Always check and keep your machine clear of these flammable materials.
- Check for any leaks from fuel, lube oil or hydraulic oil lines. Repair faults and clean spilled oil as necessary.

**For additional information, refer to Section "14-1. Checking before starting the engine".**

- Check to see where fire extinguishers are located and know how to use them.



#### Inspect around the operator's seat

- Dirt, oil and snow on the floor, levers, handrails or steps are slippery and hazardous. Remove them all completely.
- Keep parts and tools away from the operator's seat as they may damage the control levers or switches or create any other hazards.

**Provide adequate ventilation when working in an enclosed area**

Engine exhaust fumes are harmful to the human body and their inhalation is extremely hazardous. When starting the engine in an enclosed area, open the windows and doors for ventilation. Also do not idle the engine unnecessarily or leave the engine running while the machine is not in use.

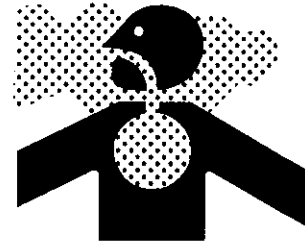

000283-00X

**Keep the cabin window clean**

- Keep the surface of the cabin windows and the headlights clean for clear view.
- Make sure that your machine is equipped with headlights and all required working lamps, and that they work properly.

**Fasten the seatbelt**

- For your safety, ROPS (Roll-Over Protective Structure)/FOPS (Falling Objects Protective Structures) with a seatbelt is installed.
- Always fasten the seatbelt across the pelvic region and adjust snugly before you operate the machine.  
Never fasten a seatbelt across the abdomen.
- The seatbelt must be replaced after an accident.
- In addition the seat and seat mounting must be checked by your dealer after an accident has occurred.
- If the seat and seat mounting are damaged, they must be replaced.

**ROPS/FOPS**

- Never modify the structural member of ROPS/FOPS.
- If ROPS/FOPS is damaged, replace it immediately to prevent bodily injury.  
Never repair or modify it.

**Caution for the protection of plants from hot wind**

The hot wind of the high temperature is exhausted from the muffler and the radiator.  
If this hot wind hits plants directly, they will die.

Give a cover board to protect plants from the hot wind when working near the arranging fence or plant.



## 8-2. Precautions for starting the engine, working and parking

### Signal before starting the engine

- Check the machine carefully before initial start up for the day.
- Make sure there are no persons near the machine before getting on it.
- Never start the engine when the "SERVICING IN PROGRESS" tag is attached to the control system.
- Sound the horn to alert people nearby before starting the engine.
- Be sure to start the engine and operate the machine from the operator's seat only.
- Do not allow any other persons to get on the machine.

### Check the position of the blade before operating the machine

- Check the position of the blade before operating the travel levers. When the blade is located in the back, the operation of the travel levers is reversed.

**For instructions on How the machine travels, refer to Section "14-4. Traveling".**

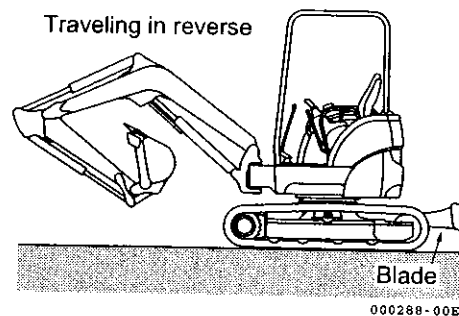

### Make sure there are no persons nearby when turning or reversing the machine

- A signal person should be provided for safety when the work site is hazardous or when visibility is poor.
- Keep all other persons away from the work site or the traveling path of the machine.
- Alert persons nearby with a horn or other signal before starting the machine.
- The machine permits a limited range of vision toward the rear. Make sure there are no persons behind the machine before reversing.

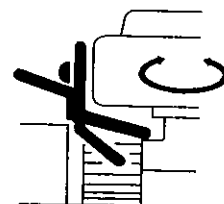
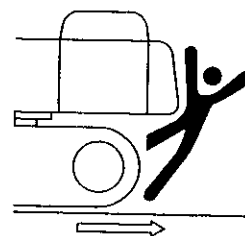

000289-00X

**Precautions for traveling**

- When traveling with the machine, keep the bucket 16 to 20 in. (40 to 50 cm) above the ground with boom and arm folded as illustrated below.
- If you need to operate the control levers while traveling, never move them abruptly.
- Travel the machine at a low speed and slow down when turning on rough terrain.
- Avoid running over obstacles if possible. If unavoidable, run the machine at a low speed while keeping the implement close to the ground. Never run over obstacles that may cause the machine to tilt more than 10 degrees.

Orientation in travel

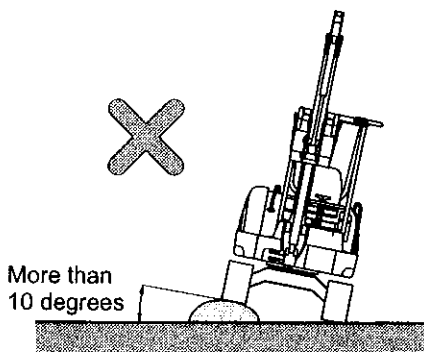
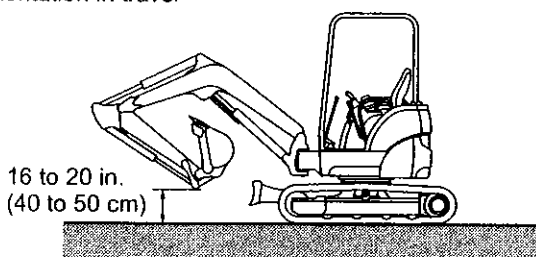

000290-01E

**Running the machine on a slope**

- Run the machine carefully on a slope to avoid overturning or skidding sideways.
- When running the machine on a slope, keep the bucket 8 to 12 in. (20 to 30) cm above the ground so that you can immediately lower it to the ground and stop the machine in an emergency.
- Never turn the machine on a slope or run it across the slope. Move down to flat ground and then make a turn.

**For instructions on how to run the machine on a slope, refer to Section "14-11. Precautions for going up and down a slope".**

- On grasses, dead leaves or a wet metal plate, even with a slight gradient, the machine will easily slip. Under those circumstances, run the machine carefully at low speed to prevent it from skidding.

Going down a slope

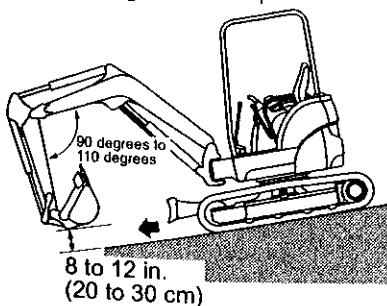

Going up a slope

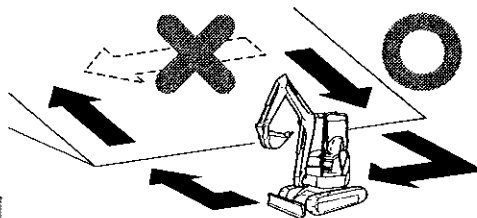
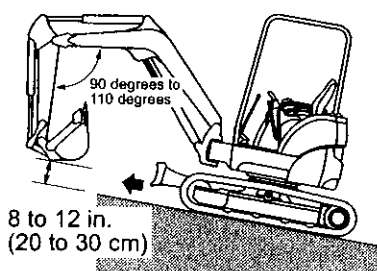

000291-01E

**Avoid hazardous work**

- Undermining a cliff is dangerous as it may cause a rockslide or landslide.
- Undercutting the machine is dangerous as it may cause a cave-in, resulting in the machine overturning and falling into the excavation.

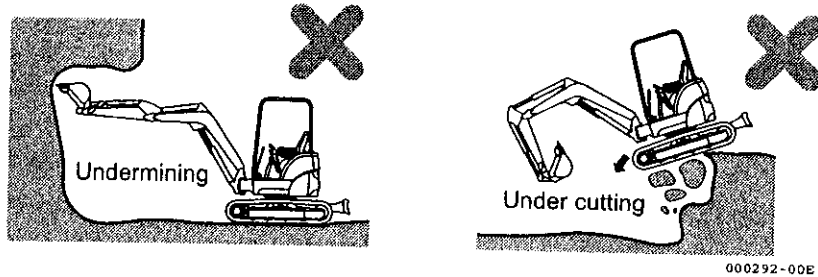

**Never suspend loads without a hooked bucket**

- Suspending loads without a hooked bucket is extremely hazardous.
- To suspend loads, the machine must be equipped with a hooked bucket specifically designed for the purpose.

**For information on suspending loads, refer to Section "14-9. Precautions for operating the implement".**

**⚠ DANGER**

**Keep away from electric power lines**

- Working in the vicinity of overhead electric power lines presents a very serious hazard and special precautions must be taken. For purposes of this manual you are considered to be working in the vicinity of overhead power lines when the attachment or load of your excavator, in any position, can reach to within the minimum distances shown below.
- The following procedures are effective in preventing accidents or injuries.
  - 1) Wear shoes with rubber or leather soles.
  - 2) Use a signal person to warn the operator when the machine is getting too close to a power line.
- If the machine should contact a wire, the operator must not leave the seat.
- When working near power lines, caution all ground personnel to stand clear of the machine.
- To determine the transmission voltage at the working site, contact the electric utility concerned.

	Transmission voltage (V)	Minimum safe distance [ft. (mm)]
Power distribution	100/200 or less	6.6 (2000) or more
	6600 or less	6.6 (2000) or more
Transmission line	22000 or less	9.8 (3000) or more
	66000 or less	13.1 (4000) or more
	154000 or less	16.4 (5000) or more
	275000 or less	23.0 (7000) or more

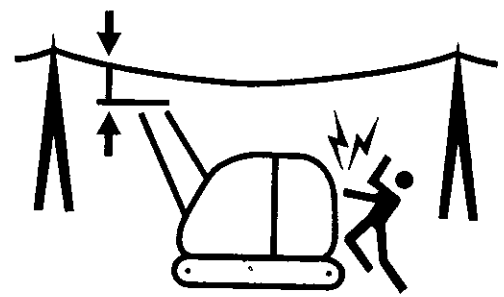

**Prevent bumping the implements**

- When traveling through tunnels or under bridges, or working at a site near other overhead obstacles, operate the machine carefully so as not to bump the boom, arm, or the implement against those overhead obstacles.

**Work only where visibility is good**

- When working in a dark place, light up the area with the work lights and head lights, and prepare extra lighting equipment as necessary.
- Stop working when fog, snow or rain impedes your view.

**Work carefully in a snow-covered areas**

- A snow-covered ground and icy roads are dangerous as they may cause the machine to skid even on a slight slope. Run the machine at low speed, and never start, stop or turn abruptly on such ground or under such road conditions.
- Be careful removing snow as road shoulders or other hazards may be buried under snow.

**Unstable ground creates a high possibility of overturn**

- Keep away from cliffs, road shoulders or trenches if possible as the ground near them is unstable. The ground may crumble due to the weight or vibrations of the machine, resulting in an overturn or fall of the machine. Be particularly careful when working immediately after rainstorm or after blasting as the ground may be unstable.
- Ground-fills or ground near a ditch may be unstable and may crumble due to the weight or vibrations of the machine, causing the machine to tilt. Much caution must be taken in working in these areas.
- When working in an area where is a high possibility of falling rocks, wear a hard-hat and stay under the canopy.

**Using the quick coupler**

- Observe the procedures of mounting and dismounting the bucket.
- Always securely and correctly install the lock pin when the bucket is mounted on the quick coupler.
- Replace the lock pin whenever it is damaged or lost.

**For information of handling the quick coupler, refer to Section "14-14. Handling quick coupler".**

### Working on a slope

- Be aware that the machine may tip over when swinging the upperstructure or swinging the implement on a slope.
- Never swing the upperstructure toward the downward side of the slope with earth loaded in the bucket.  
(See the illustration at upper right.)
- If swinging is unavoidable, level off a work area to maintain the machine as horizontal as possible, then swing.  
(See the illustration at lower right.)

**For levelling off a work area, refer to Section "14-11. Precautions for going up and down a slope".**

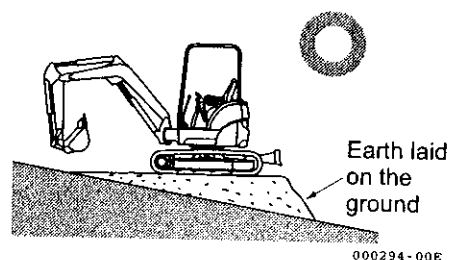
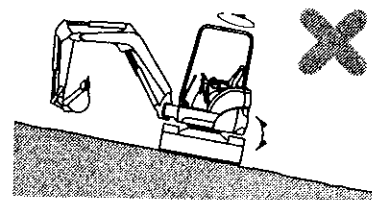

### Parking the machine

- Park on level ground. If park on a slope is unavoidable, block the tracks with solid pieces of wood and dig the bucket into the ground. (See the illustration at right.)
- If necessary to park the machine on the side of a road, set up a warning flag, fence, or lamp that can be easily recognized by passing cars and pedestrians but does not impede them.

**For parking procedures, refer to Section "14-15. Parking the machine".**

- When leaving the operator's seat, do the following:

- (1) Be sure to place the bucket on the ground.
- (2) Set the lock lever to the lock position.
- (3) Stop the engine.
- (4) Set all the locks to the lock position.
- (5) Be sure to take the key out of the starter switch.

**For information about parking procedures, refer to Section "14-15. Parking the machine".**

**For information about the parts to be locked, refer to Section "14-19. Locking".**

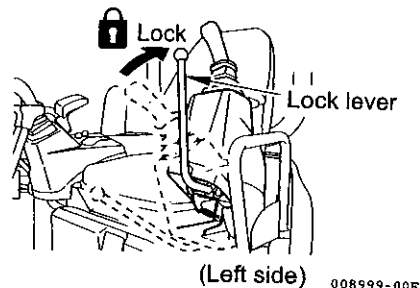
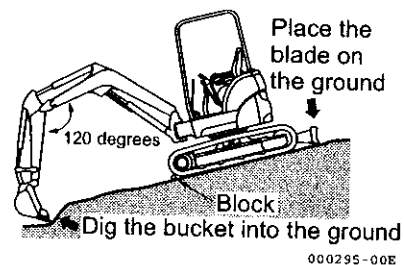

(Left side)

**8-3. Precautions for transportation**

**Precautions for loading and unloading the machine**

- Be careful in loading and unloading the machine, because it is a job of high hazard potential.
- Load or unload the machine at a low engine speed, and low travel speed.
- Load or unload the machine on the level, solid ground away from the shoulder of the road.
- Use ramp plates of adequate strength with hooks on their ends.

Check to see that the ramp plates are wide, long, and thick enough to sustain the load so that you can load or unload the machine safely. Support the ramp plates with blocks, to provide additional strength.

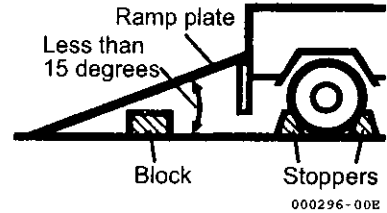

- Securely hook the ramp plates to the deck of the truck so that they will not come off.
- Remove grease, oil, and other slippery deposits from the ramp plates, and remove mud from the tracks to prevent the machine from skidding on the ramp plates.
- Do not load or unload the machine if the ramp plates are slippery because of rain, snow or ice.
- Never change travel direction while on the ramp plates. If you need to change travel direction, go down the ramp plates, and change direction on the ground.
- After loading the machine, block it with lumber and secure the machine with a chain or a wire rope so that the machine will not move during transit.

**For instructions on loading and unloading the machine, refer to Section "15. Transportation".**

**For instructions on securing the machine, refer to Section "15. Transportation".**

**Precautions for transporting**

- Transport the machine safely in accordance with the laws associated with applicable law.
- Select a travel route consistent with the width, height and weight of the machine loaded on the truck.

### 8-4. Precautions for the battery

#### **DANGER**

##### Be careful in handling the battery

- The battery electrolyte contains dilute sulfuric acid, which can severely burn the eyes or skin. Always wear safety goggles and protective clothing when servicing the battery. If contact with the eyes or skin should occur, flush with a large amount of water and obtain prompt medical treatment.
- Because flammable hydrogen gas is produced by the battery, ignition and explosion may occur. Keep flames and sparks away from the battery.
- Do not use or charge the battery if the battery electrolyte level is below the lower limit. Doing so may cause the battery to explode. Always check the battery electrolyte level before starting the engine. If the electrolyte level is low, add distilled water to the upper limit.
- If you swallow battery electrolyte by mistake, drink a large amount of water, milk, or fresh eggs, and obtain medical treatment immediately.
- Before checking or handling the battery, be sure to stop the engine and turn the starter switch to the "OFF" position.
- Be careful not to cause a short circuit by placing a tool across the terminals of the battery.
- If a terminal connection is loose, sparks may be generated due to contact failure, causing possible ignition and explosion. Be sure to connect the terminals securely.

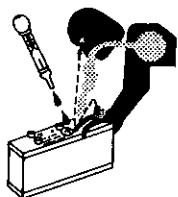

000297-00X

#### **WARNING**

##### Observe the procedures for starting the engine using booster cables

- When you start the engine using booster cables, wear safety goggles.
- If you start the engine by taking electric power from another machine, do not allow your machine to contact the other machine.
- To connect the booster cables, begin with the positive terminal, and to disconnect them, begin with the negative terminal (ground side).
- If a tool simultaneously touches the positive terminal and the machine, potentially hazardous sparks may be generated.
- Do not connect the booster cables to the terminals in reverse polarity. In other words, never connect the negative terminal on one machine to the positive terminal on the other machine.
- As the last step, connect the negative booster cable terminal to the upper structure frame. At that time, sparks will be generated. Consequently, connect the terminal to a point as far away from the battery as possible.

**For information about starting the engine using booster cables, refer to Section "18-3. If the battery is overdischarged".**

### 8-5. Precautions for towing

#### Hook the wire rope on the frame when towing

- Improper towing procedures can cause death or serious injury.
- When towing a machine with another machine, use a wire rope strong enough to sustain the machine weight.
- Never tow a machine on a slope.
- Do not use a towing rope that is kinked, distorted or damaged.
- Do not ride on the towing cable or on the wire rope.
- When connecting an object to be towed, make sure that no person enters the space between the machine and the object.
- To connect an object to be towed, hook the sling belt as illustrated at right.
- The hook provided on the machine is intended for stabilizing the machine during transporting. Never use it for towing.

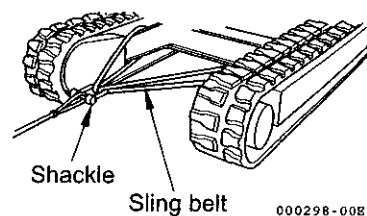

**For information about towing the machine, refer to Section "18-2. Towing".**



## 8-6. Precautions for hooked bucket

### 8-6-1. General precautions

#### Special hook

- A dedicated hook is required for suspending a load.
- The following procedures are extremely dangerous and must never be attempted:
  - Suspending a load with a wire rope hooked on the bucket teeth
  - Suspending a load with the wire rope directly hooked on the boom or the arm

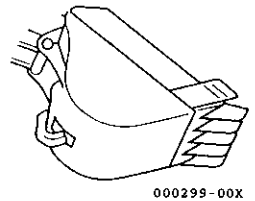

#### Checking the hook

- Check for abnormalities before suspending a load, as follows:
  - No cracks or deformations in the suspension sling belt and fittings
  - No abnormalities in the locking devices
- Every time you make a voluntary monthly check or a specified annual check, check all suspension gear for abnormalities and enter the results in the inspection records.

#### Securely attach a wire rope to the hook

- To suspend a load, securely attach a wire rope to the dedicated suspension hook.

#### Precautions for selecting a place to park the machine

- Survey the terrain and soil and select a solid, level spot for parking the machine, for maximum stability.

#### Do not use the machine for other than the specified purpose

- Never suspend a person together with the load, under any circumstances, because of the extreme danger.

#### Keep out of the radius of the work area

- Never permit anyone to enter the work area because of the danger of spilling or swinging the load.

**Designate a leader to supervise suspension work**

- When suspending a load, designate a leader to supervise the work and follow the leader's instructions.
- Follow the leader's instructions for the handling methods and procedures.
- Define hand signals in advance for communicating, and respond to the leader's signals.

**Handling the wire rope**

- When handling the wire rope, use leather gloves.

**For additional information about the hooked bucket, refer to Section "32. Handling the Hooked Bucket".**

**8-6-2. Precautions for suspending a load**

**Move a suspended load slowly**

- Raise and swing a suspended load slowly.
- Do not operate the control levers or the accelerator lever abruptly.
- The swing speed is three to four times higher than that of a truck crane. Swing the upper structure slowly.

**Do not leave the operator's seat**

- Never leave the operator's seat with a load suspended.

**Do not operate the machine unsafely**

- Working beyond the machine's capacity can cause accidents or failures. Suspend loads within the machine's capacity.
- Do not suspend a load greater than the specified maximum, or subject to a sharp impact. Those actions may damage the machine.
- Do not move the suspended load sideways or toward the machine, or haul it. Those actions are extremely dangerous.

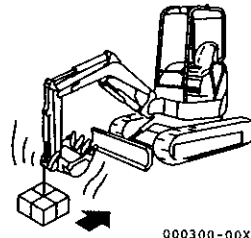
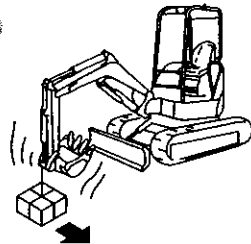

000300-00X

**Do not travel while suspending a load**

- Do not travel while suspending a load.

**Make sure of the posture of the machine**

- If the bucket hook is not maintained in a vertical position, the wire rope or the shackle may slip off the hook. Be careful to maintain a vertical hook angle, so that the wire rope or the shackle will not come off.

## 9. Precautions for Servicing

**⚠ WARNING** Neglecting these instructions may cause extreme hazards.

### 9-1. Precautions before servicing

#### Attach the "SERVICING IN PROGRESS" tag to an implement control lever

- If another person should start the engine or operate the control levers while service is in progress, the service personnel can sustain serious bodily injury.

Attach the "SERVICING IN PROGRESS" tag indicating "Servicing in Progress" to one of the implement control levers.

The "SERVICING IN PROGRESS" tag is enclosed with the Operation Manual.

Article number : 172437-03250

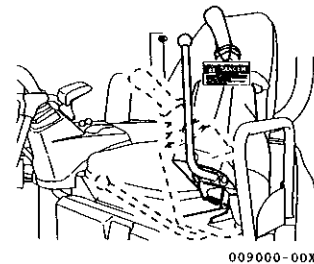
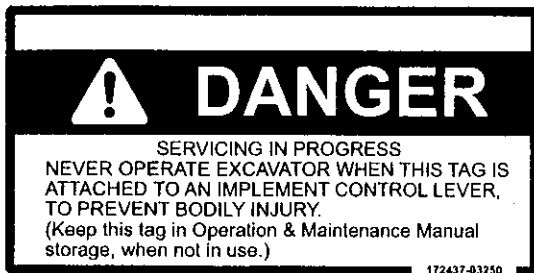

#### Use appropriate tools

- Using damaged or worn tools or using tools inappropriate for the required application is very dangerous, and may also cause damage to the machine. Make sure to use the tools that are appropriate for the specific job.

**For information about tools, refer to Section "24-1. Required tools".**

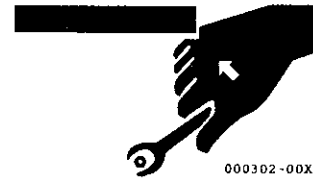

## 10. Safety Messages (Warning Labels)

There are a number of Warning Labels on the machine. Full descriptions of all Warning Labels and their locations are reviewed in this section. Periodically confirm whether all Warning Labels are still mounted in their correct locations and can be easily read.

If a warning label is missing, damaged or cannot be read, it must be promptly replaced. Also, if a warning label was mounted on a part which is replaced, a new warning label must be installed on the replaced part.

Contact your dealer to obtain new labels. The part code number is shown on each warning label as well as on the reproductions in this manual.

### 10-1. Location of warning labels

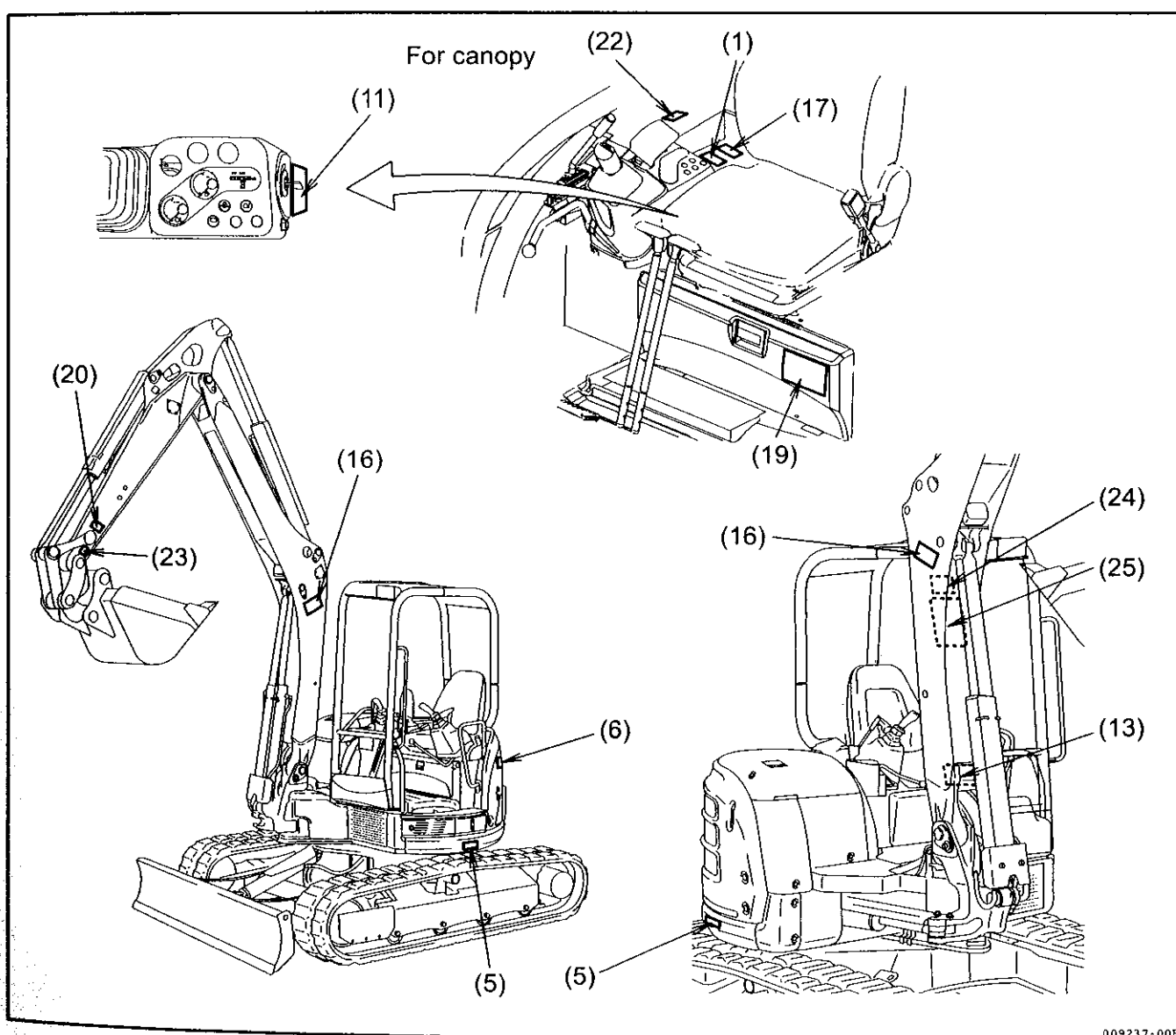

009237-00B

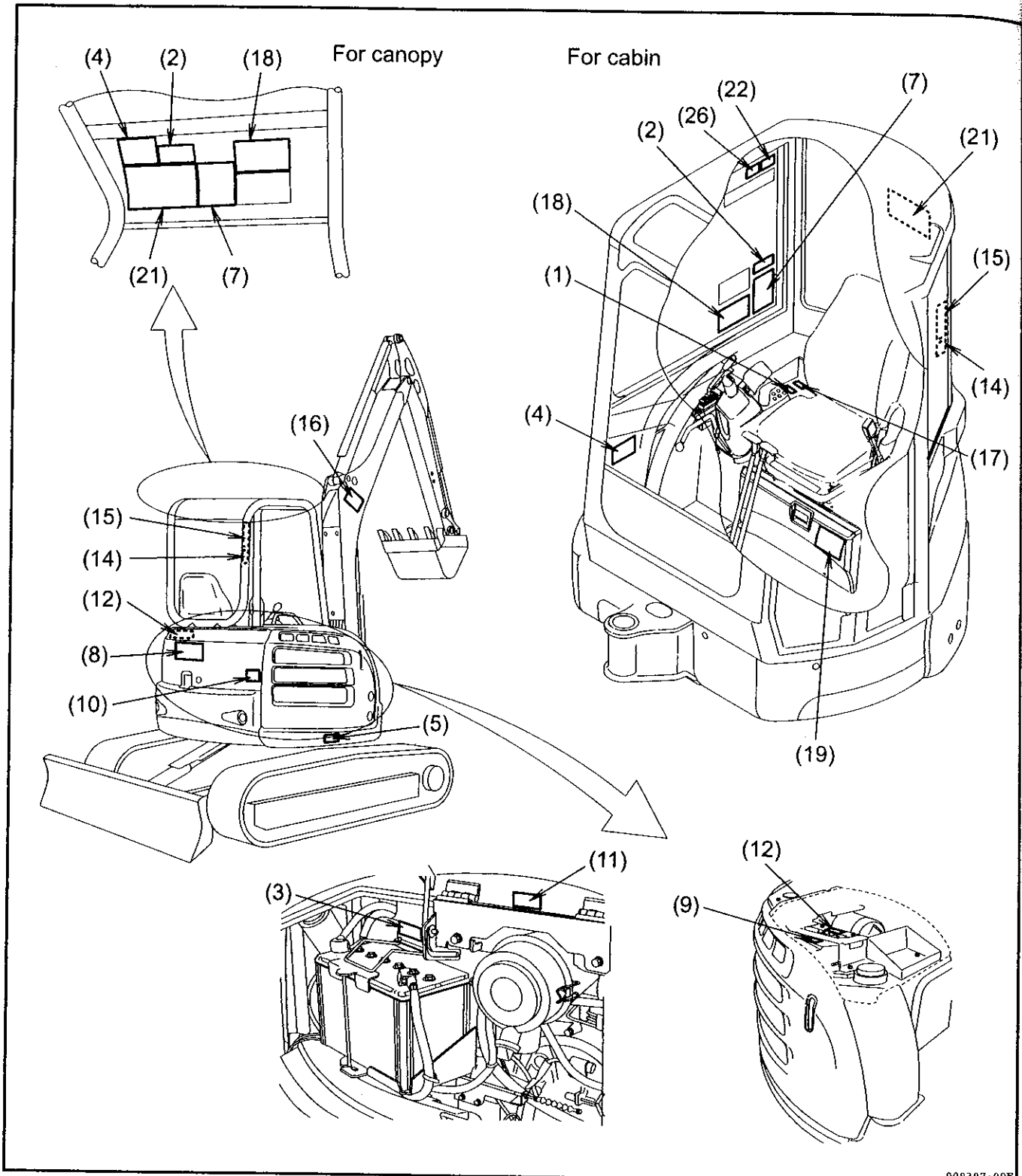

009307-00B

(1) 172437-03301

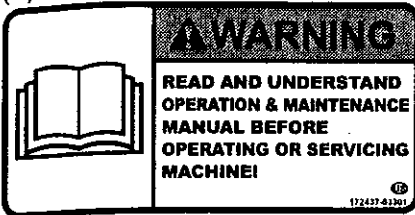

(2) 172437-03312

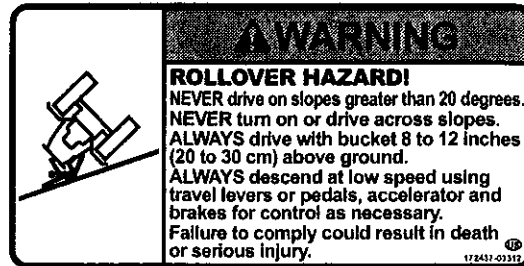

(3) 172437-03322

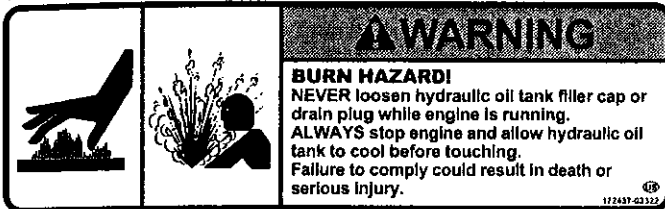

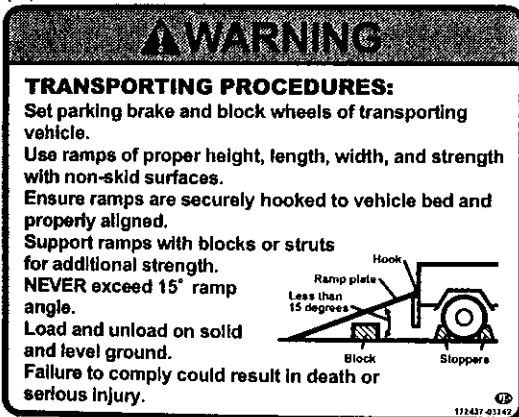

(4) 172437-03342

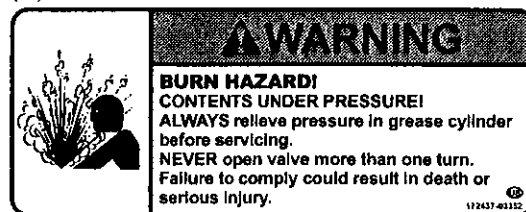

(5) 172437-03352



(6) 172437-03361

<b>⚠ DANGER</b>	
	<b>EXPLOSION HAZARD!</b> Improper connection or disconnection can cause an explosion. <b>ALWAYS</b> follow Operation & Maintenance Manual when using booster cables. Battery generates hydrogen gas which can explode if ignited. <b>NEVER</b> smoke or introduce flames or sparks near battery.
	<b>BURN HAZARD!</b> Battery contains sulfuric acid which burns skin. <b>ALWAYS</b> wear goggle and protective clothing when servicing battery. Flush with water and get prompt medical treatment if contact should occur.
	Failure to comply will result in death or serious injury. <small>172437-03361</small>

(7) 172437-03372

<b>⚠ WARNING</b>
<b>PROPER OPERATING PROCEDURE:</b> <b>ALWAYS</b> wear seat belt. <b>NEVER</b> start excavator unless all safety guards are in place and implement controls are in neutral. <b>NEVER</b> operate with people on or near excavator. <b>Start</b> from operator's seat only. <b>NEVER</b> start engine standing on ground. Inspect for overhead power lines, obstructions, holes and drop-offs and note location of underground utility lines before operation. <b>NEVER</b> leave operator's seat until all implements are grounded, hydraulic pressure is relieved for all controls, lock levers are locked and ignition key has been removed. <b>NEVER</b> attempt to raise chassis off ground with blade and attachment.
<small>172437-03372</small>

(8) 172437-03381

<b>⚠ DANGER</b>	
	
<b>CRUSH HAZARD!</b> Stay clear of swing range of Excavator implements and machine tail. Failure to comply will result in death or serious injury. <small>172437-03381</small>	

(9) 172437-03391

	<b>⚠ WARNING</b> <b>BURN HAZARD!</b> <b>CONTENTS UNDER PRESSURE!</b> <b>ALWAYS</b> stop engine and allow radiator to cool before removing cap. Failure to comply could result in death or serious injury. <small>172437-03391</small>
---	---

(10) 172437-03402

<b>⚠ WARNING</b>
<b>BURN HAZARD!</b> Engine is hot! Allow to cool before servicing. Failure to comply to any of above could result in death or serious injury. <small>172437-03402</small>



(11) 172A36-03411

**WARNING**

**SERVER HAZARD!**  
**MOVING FAN BLADE AND BELTS!**  
 NEVER open engine access panel while engine is running.  
 Stop engine and remove key before servicing.  
 Failure to comply could result in death or serious injury.



172A36-03411

(12) 172437-03422

**WARNING**

**BURN HAZARD!**  
 ALWAYS allow exhaust pipe and muffler to cool before servicing.  
 Exhaust system cools slowly.  
 Failure to comply could result in death or serious injury.



172437-03422

(13) 172437-03432

**WARNING**

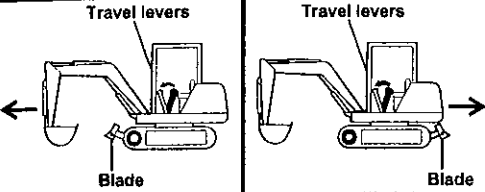

**CRUSH HAZARD!**  
 Machine travels in direction of blade when travel levers are pushed away from operator.  
 NEVER move excavator before confirming location of blade and direction of travel.  
 Failure to comply could result in death or serious injury.

172437-03432

(14) 172437-03441

**WARNING**

NEVER repair or modify a ROPS.  
 ALWAYS replace ROPS if damaged.  
 Failure to comply could result in death or serious injury.

172437-03441

(15) 172437-03451

**WARNING**

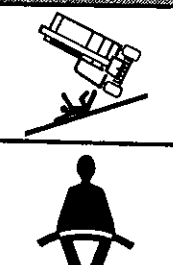

**ROLL-OVER HAZARD!**  
 NEVER operate without a seat belt.  
 NEVER jump if excavator rolls.

172437-03451

(16) 172437-03461

**WARNING**



**CRUSH HAZARD!**  
**STAY CLEAR OF AREA!**  
 Failure to comply could result in death or serious injury.

172437-03461

10. Safety Messages (Warning Labels)

**WARNING** Neglecting these instructions may cause extreme hazards.

(17) 172437-03471

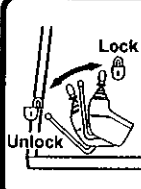
	<b>WARNING</b>
	<p><b>LOCK LEVERS BEFORE LEAVING SEAT!</b>                  Never leave operator's seat unless all lock levers are in locked position, and starter switch key has been removed.                  Failure to comply could result in death or serious injury.</p>

(18) 172437-03601

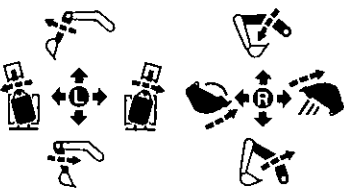
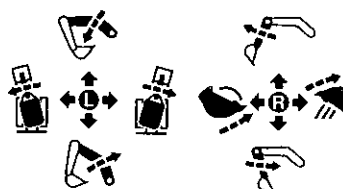
<b>WARNING</b>	
<b>OPERATING PATTERN</b>	
	
<b>A STANDARD (ISO)</b>	<b>B OPTION</b>
Confirm location of Pattern Change Lever before operating. Failure to comply could result in death or serious injury.	

(19) 172472-03141

	<b>WARNING</b>
	<p><b>FALL HAZARD!</b>                  Follow proper procedures when getting on and off machine.</p> <ul style="list-style-type: none"> <li>• Always face machine.</li> <li>• Always use steps and handrails.</li> <li>• Always maintain three-point contact with steps and handrails.</li> <li>• Never use control and lock levers as handrails.</li> <li>• Never attempt to get on or off a moving machine.</li> <li>• Never jump on or off of any machine.</li> </ul> <p>Failure to comply could result in death or serious injury.</p>

(20) 172472-03330

	<b>WARNING</b>
	<p><b>CRUSH HAZARD!</b>                  ATTACHMENT MAY FALL!                  Always install lockpin.                  Always replace lockpin if damaged or lost.                  Failure to comply could result in death or serious injury.</p>

(21)  
172A47-03363

**WARNING**

**TIP-OVER HAZARD!**  
Never allow total bucket weight to exceed excavator lift capacity.

MODEL  
ViO45-5, 5B EXCAVATOR  
Quick coupler Spec.

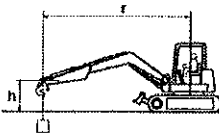

Note where applicable specifications conform to ISO standards.  
Loads shown in table include weight of standard bucket (280 lbs. [127 kg])  
Weight of all lifting devices and attachment must be deducted to determine load that can be lifted.  
Lift point is bucket hinge point with bucket fully curled.  
Specifications subject to change without notice.  
\*Rated Hydraulic lift capacity

LIFT POINT HEIGHT h in. (mm)	(r) LIFT RADIUS · in. (mm)				(r) LIFT RADIUS · in. (mm)				(r) LIFT RADIUS · in. (mm)			
	RATED LIFT CAPACITY OVER END BLADE DOWN · lbs. (kg)				RATED LIFT CAPACITY OVER END BLADE UP · lbs. (kg)				RATED LIFT CAPACITY OVER SIDE BLADE UP · lbs. (kg)			
	MAX	157.5 (4000)	118.1 (3000)	98.5 (2500)	MAX	157.5 (4000)	118.1 (3000)	98.5 (2500)	MAX	157.5 (4000)	118.1 (3000)	98.5 (2500)
157.5 (4000)	*1851 (840)				*1741 (790)				*1763 (800)			
118.1 (3000)	*1918 (870)	*1851 (840)			*1741 (790)				1102 (500)	1410 (640)		
78.7 (2000)	*2006 (910)	*2150 (980)	*2733 (1240)	*3284 (1490)	992 (450)	1455 (660)	*2513 (1140)	*3196 (1450)	903 (410)	1322 (600)	*2623 (1190)	*3218 (1460)
39.4 (1000)	*2116 (960)	*2557 (1160)	*3659 (1660)	*4651 (2110)	947 (430)	1366 (620)	2204 (1000)	2932 (1330)	859 (390)	1234 (560)	2006 (910)	2623 (1190)
Ground (0)	*2228 (1010)	*2755 (1250)	*3980 (1810)	*5028 (2280)	992 (450)	1300 (590)	2050 (930)	2711 (1230)	903 (410)	1168 (530)	1851 (840)	2447 (1110)
-39.4 (-1000)	*2336 (1060)	*2645 (1200)	*3769 (1710)	*4872 (2210)	1168 (530)	1300 (590)	2028 (920)	2821 (1280)	1058 (480)	1168 (530)	2028 (920)	3284 (1490)
-78.7 (-2000)	*2336 (1060)		*2777 (1260)	*3373 (1530)	1895 (860)		2160 (980)	2821 (1280)	1785 (810)		1984 (900)	2557 (1160)

172A48-03393

**WARNING**

**TIP-OVER HAZARD!**  
Never allow total bucket weight to exceed excavator lift capacity.

MODEL  
ViO55-5, 5B EXCAVATOR  
Quick coupler Spec.

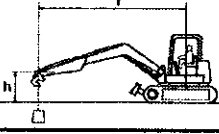

Note where applicable specifications conform to ISO standards.  
Loads shown in table include weight of standard bucket (291 lbs. [132 kg])  
Weight of all lifting devices and attachment must be deducted to determine load that can be lifted.  
Lift point is bucket hinge point with bucket fully curled.  
Specifications subject to change without notice.  
\*Rated Hydraulic lift capacity

LIFT POINT HEIGHT h in. (mm)	(r) LIFT RADIUS · in. (mm)				(r) LIFT RADIUS · in. (mm)				(r) LIFT RADIUS · in. (mm)			
	RATED LIFT CAPACITY OVER END BLADE DOWN · lbs. (kg)				RATED LIFT CAPACITY OVER END BLADE UP · lbs. (kg)				RATED LIFT CAPACITY OVER SIDE BLADE UP · lbs. (kg)			
	MAX	157.5 (4000)	118.1 (3000)	98.5 (2500)	MAX	157.5 (4000)	118.1 (3000)	98.5 (2500)	MAX	157.5 (4000)	118.1 (3000)	98.5 (2500)
157.5 (4000)	*2006 (910)	*1873 (850)			*1873 (850)	*1807 (820)			*1840 (860)	*1873 (850)		
118.1 (3000)	*1962 (890)	*1984 (900)			1300 (590)	*2028 (920)			1234 (560)	*1962 (890)		
78.7 (2000)	*2050 (930)	*2447 (1110)	*3218 (1460)	*4078 (1850)	1190 (540)	1962 (890)	*3086 (1400)	*3880 (1760)	1102 (500)	1828 (830)	*3196 (1450)	*4056 (1840)
39.4 (1000)	*2138 (970)	*2888 (1310)	*4188 (1900)	*5511 (2500)	1124 (510)	1829 (830)	2910 (1320)	3769 (1710)	1036 (470)	1697 (770)	2645 (1200)	3527 (1600)
Ground (0)	*2182 (990)	*3130 (1420)	*4519 (2050)	*5621 (2550)	1168 (530)	1719 (780)	2689 (1220)	3549 (1610)	1102 (500)	1631 (740)	2513 (1140)	3240 (1470)
-39.4 (-1000)	*2248 (1020)	*2898 (1380)	*4232 (1920)	*5248 (2380)	1344 (610)	1687 (770)	2733 (1240)	3659 (1660)	1256 (570)	1605 (730)	2491 (1130)	3351 (1520)
-78.7 (-2000)	*2160 (980)		*3439 (1560)	*4034 (1830)	*2138 (970)		2821 (1280)	4254 (1930)	*2008 (910)		2579 (1170)	3365 (1540)

(22) 172472-03241

**Pull out**



**CAUTION**

**DO NOT DAMAGE LOCK PIN!**  
Pull lock pin out when changing attachment.

172472-03241

(23) 172472-03261

**WARNING**

**SEVERE HAZARD!**  
NEVER insert fingers into pin hole.  
Failure to comply could result in death or serious injury.



172472-03261

10. Safety Messages (Warning Labels)

**WARNING** Neglecting these instructions may cause extreme hazard

(24) 172472-03271

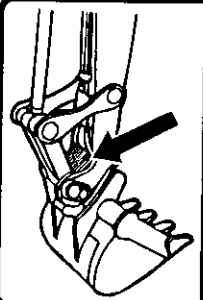
	<p><b>CAUTION</b></p> <p>Be sure to remove earth and sand piled in quick coupler. This may damage hydraulic hoses.</p> <p><small>172472-03271</small></p>
---	---

(25) 172472-03281

<p><b>WARNING</b></p> <p><b>CRUSH HAZARD!</b></p>	
	
<p><b>NEVER</b> suspend load with quick coupler hook. Load could fall.</p>	
	<p><b>ATTACHMENT COULD FALL!</b> <b>ALWAYS</b> install lock pin to prevent attachment from falling off. Ensure quick coupler securely holds attachment. Quick coupler operating speed slows in cold weather.</p>
	<p><b>TIP-OVER HAZARD!</b> <b>ALWAYS</b> park on solid, level ground and place attachment on ground before operating quick coupler. Failure to comply could result in death or serious injury.</p>
<p>To prevent breakdown or sudden operation of attachment, never open switch box cover except to dismount or mount attachment. Failure to comply could result in death or serious injury.</p> <p><small>172472-03281</small></p>	

(26) 172437-03551

<p><b>WARNING</b></p> <p><b>WINDOW CAN FALL!</b> Always lock window securely. Failure to comply could result in death or serious injury.</p> <p><small>172437-03551</small></p>
---

# 11. SAFETY (ViO55-5B Angle blade spec.)

## 11-1. Safety Messages (Warning Labels)

There are a number of Warning Labels on the machine. Full descriptions of all Warning Labels and their locations are reviewed in this section. Periodically confirm whether all Warning Labels are still mounted in their correct locations and can be easily read.

If a warning label is missing, damaged or cannot be read, it must be promptly replaced. Also, if a warning label was mounted on a part which is replaced, a new warning label must be installed on the replaced part. Contact your dealer to obtain new labels. The part code number is shown on each warning label as well as on the reproductions in this manual.

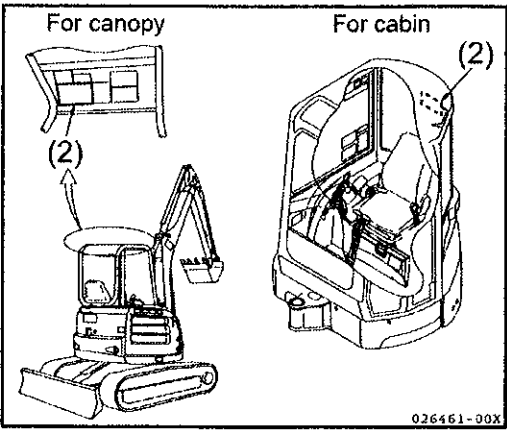
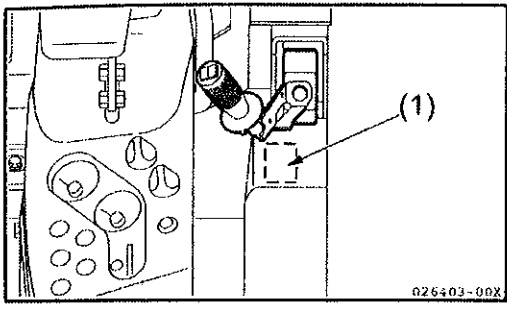

(1) 172A79-03220

**⚠ WARNING**

**PERSONAL INJURY HAZARD!**

Do not push the blade control lever to the float position while jacking up the machine. Failure to comply could result in death or serious injury.

112A79-03220

(2) 172A79-03390

**⚠ WARNING**

**TIP-OVER HAZARD!**  
Never allow total bucket weight to exceed excavator lift capacity.

**MODEL**  
**ViO55-5B EXCAVATOR**  
Quick coupler Spec.  
Angle Blade Spec.

Note where applicable specifications conform to ISO standards.  
Loads shown in table include weight of standard bucket (291 lbs. [132 kg])  
Weight of all lifting devices and attachment must be deducted to determine load that can be lifted.  
Lift point is bucket hinge point with bucket fully curled.  
Specifications subject to change without notice.

\*Rated Hydraulic lift capacity

LIFT POINT HEIGHT ft. (mm)	(r) LIFT RADIUS · in. (mm)				(r) LIFT RADIUS · in. (mm)				(r) LIFT RADIUS · in. (mm)			
	MAX	157.5 (4000)	118.1 (3000)	98.5 (2500)	MAX	157.5 (4000)	118.1 (3000)	98.5 (2500)	MAX	157.5 (4000)	118.1 (3000)	98.5 (2500)
157.5 (4000)	*1984 (900)	*1984 (900)			*1631 (740)	*1829 (830)			1631 (740)	*1873 (850)		
118.1 (3000)	*1984 (900)	*2008 (910)			1278 (580)	*1918 (870)			1386 (620)	*1984 (900)		
78.7 (2000)	*1984 (900)	*2447 (1110)	*3162 (1430)	*3902 (1770)	1124 (510)	1851 (840)	*2954 (1340)	*3747 (1700)	1146 (520)	1962 (890)	*3042 (1380)	*3658 (1750)
38.4 (1000)	*2008 (910)	*2777 (1260)	*4078 (1850)		1080 (490)	1741 (790)	2798 (1270)		1146 (520)	1763 (800)	2866 (1300)	
Ground (0)	*2094 (950)	*3042 (1380)	*4497 (2040)	*5709 (2590)	1102 (500)	1631 (740)	2901 (1180)	3461 (1570)	1146 (520)	1741 (790)	2667 (1210)	3659 (1660)
39.4 (1000)	*2094 (950)	*2866 (1300)	*4188 (1900)	*5246 (2380)	1256 (570)	1675 (760)	2601 (1180)	3549 (1610)	1322 (600)	1719 (780)	2645 (1200)	3571 (1620)
75.7 (2000)	*1940 (880)		*3218 (1460)		*1699 (730)		2601 (1180)		*1873 (850)		2733 (1240)	

015172A79-03390

For other warning labels, refer to section "10. Safety Messages (Warning Labels)".

### 11-2. Operating Precautions

Precautions for digging, lifting and suspending the machine

- When digging the ground by lowering the blade, lifting up the machine with the blade and suspending the machine, place the angle of blade in the neutral position (refer to the below-mentioned "Neutral position of the angle blade" for the neutral position). The machine may lose balance, which poses a danger, as well as cause excessive force to be imposed on the angle blade, resulting in failures.
- NEVER put the blade lever in the float position, when digging the ground by lowering the blade or lifting up the machine with the blade. NEVER go under the machine, as it may get down suddenly and cause a serious accident.

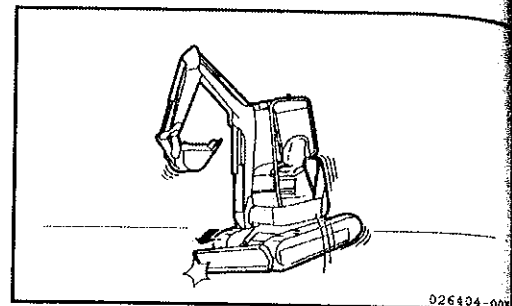

Neutral position of the angle blade

- The neutral position of the angle blade is marked as shown in the figure. Align the mark (1) (2) in the figure to place the angle blade in the neutral position.

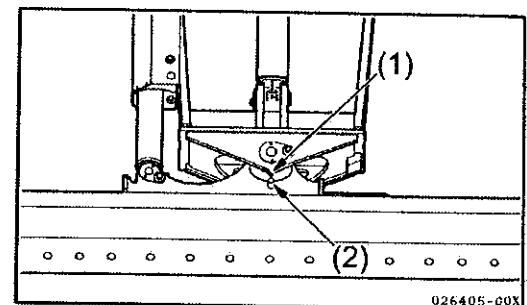

Precautions for blade operation

- NEVER bump the blade. The excessive force may be imposed on the angle blade, resulting in failures.

For the angle lever operation, refer to "19-2. Description of Control Devices" and "19-3. Operating Instruction".

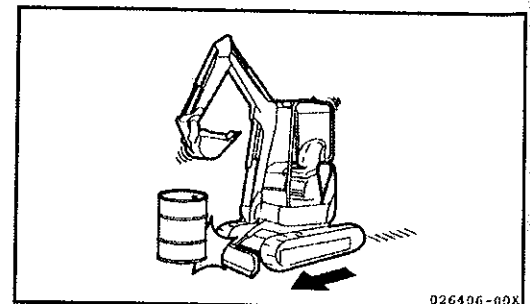

6404-00X

# OPERATION

6405-00X

6406-00X

# 12. Identification of Important Parts

## 12-1. Overview of the machine

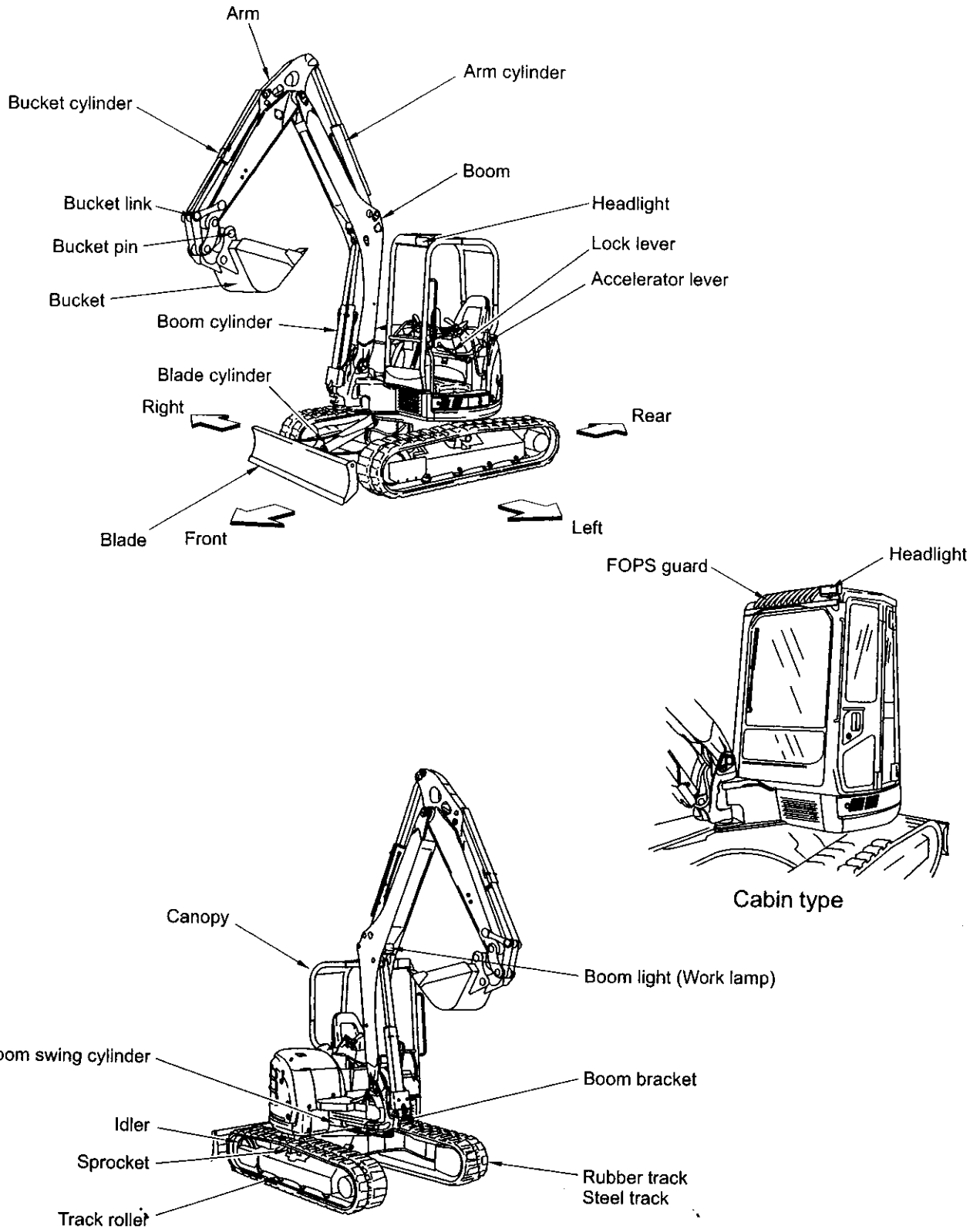



12-2. Controls and switches

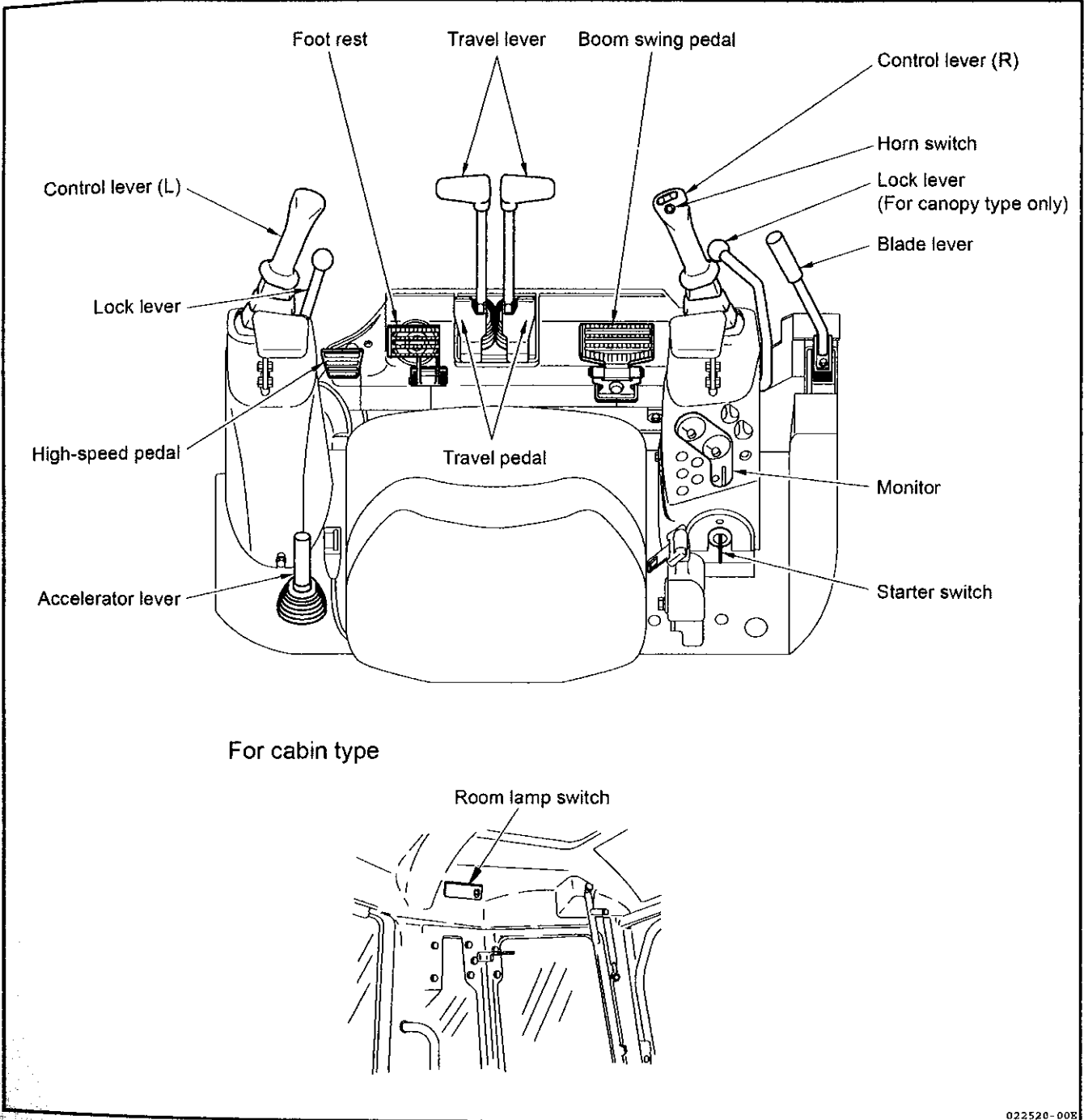

022520-002

## 13. Description of Control Devices

This section describes several of the control devices necessary to operate the machine. In order to ensure safety and comfort in working with the machine, it is imperative for you to fully understand how to operate and interact with these devices.

### 13-1. Monitor

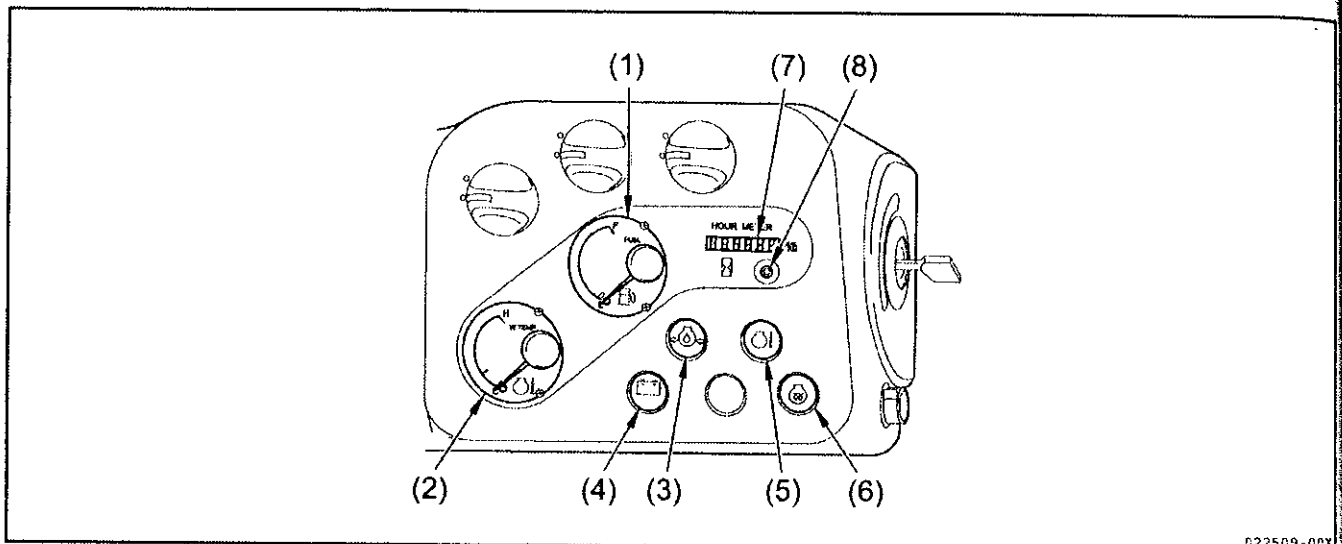

#### IMPORTANT

For start-up inspection, be sure to refer to **PART THREE: MAINTENANCE**, or Section "14. Operating Instructions" as well as the monitor messages as shown above.

#### **⚠ WARNING**

**When an indicator lamp lights and a buzzer sounds during operation, immediately stop operation and check and service the abnormality.**

When the starter switch key is in the "ON" position, the monitor lamps (3), (4) and (5) light and buzzer sounds. (Only the water temp alarm lamp (5) goes off in a few seconds.)

Normally, all monitor lamps go off after the engine starts. When there is any failure during operation, a lamp lights and buzzer sounds. (If the starter switch key is in the "ON" position and a monitor lamp does not light, its bulb must be burnt out.)

**(1) Fuel gauge**

The fuel gauge works while the starter switch key is in the "ON" position and indicates the fuel amount in the fuel tank. When the gauge pointer indicates close to E (empty), refill fuel oil soon.

- It is not abnormal that the fuel gauge may not indicate properly immediately after the starter switch key is turned to the "ON" position.
- The reading on the fuel meter scale is affected by how much the machine is slanted.

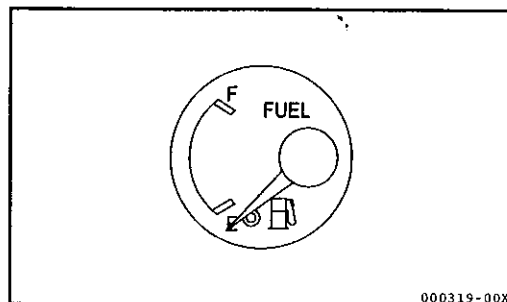
**(2) Water temp meter**

This indicates water temperature for engine.

When the water temp. meter indicates "H" and buzzer sounds during operation, idle the engine at low speed until the water temperature cools down.

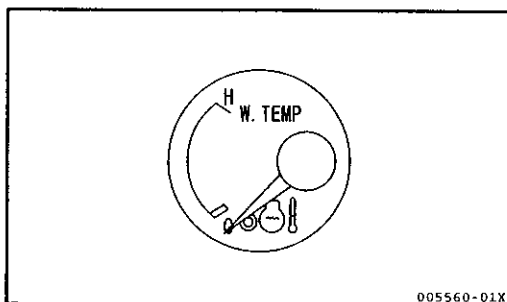
**(3) Engine oil pressure alarm lamp**

If engine oil pressure falls below the normal level, the alarm lamp will turn on and the buzzer will sound. In this event, stop the engine and inspect it according to Section "18-4. Troubleshooting".

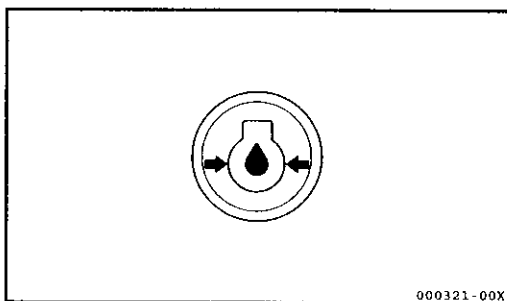
**(4) Battery charge alarm lamp**

If the battery is not charged properly, the alarm lamp will flash. In this event, inspect the battery charging circuit. If you find something abnormal with it, take corrective action by referring to Section "18-4. Troubleshooting".

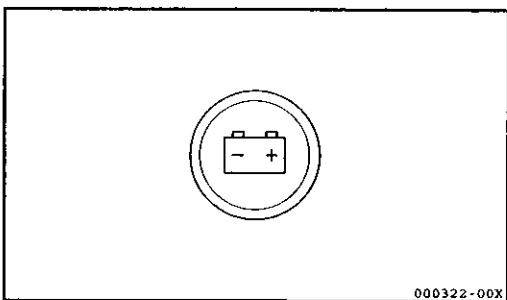
**(5) Water temp alarm lamp**

When the starter switch is turned to the "ON" position, the alarm lamp goes on and then goes off in a few seconds.

When the cooling water temperature rises abnormally during operation, the alarm lamp goes on and the buzzer sounds, indicating engine overheating.

Idle the engine for a while, and stop the engine. After the engine has cooled, take corrective actions.

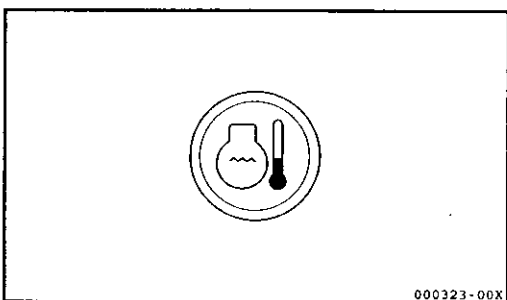

### 13. Description of Control Devices

#### (6) Preheat pilot lamp

When the starter switch is turned to the "HEAT" position, the preheat pilot lamp goes on and then goes off in 15 seconds, which indicate it is okay to finish the preheat operation.

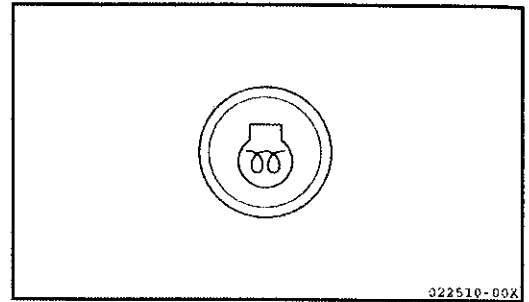

#### (7) Hourmeter

The hourmeter indicates the accumulated service hours for the machine.

The reading of the hourmeter helps you set time intervals for periodic servicing of the machine. While the engine is running, the hourmeter will continue registering even if the machine is not being operated.

- The hourmeter reading increases by "1" per hour regardless of engine rotational speed.

The digit at the far right registers "1" per 0.1 hour (6 min.).

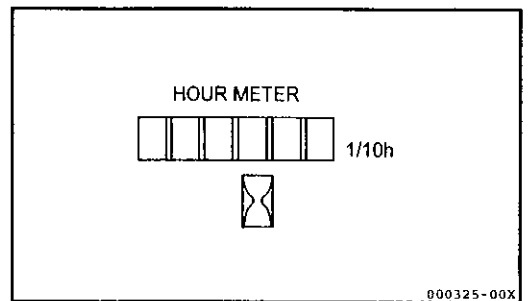
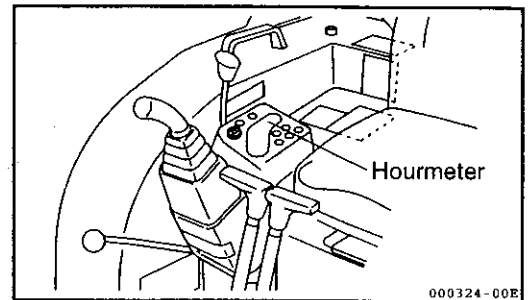

#### (8) Hourmeter display button

Even if the starter switch is in the "OFF" position, the operation time can be checked by pushing the hourmeter display button.

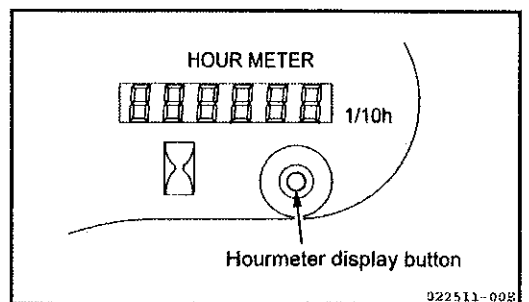

## 13-2. Switch

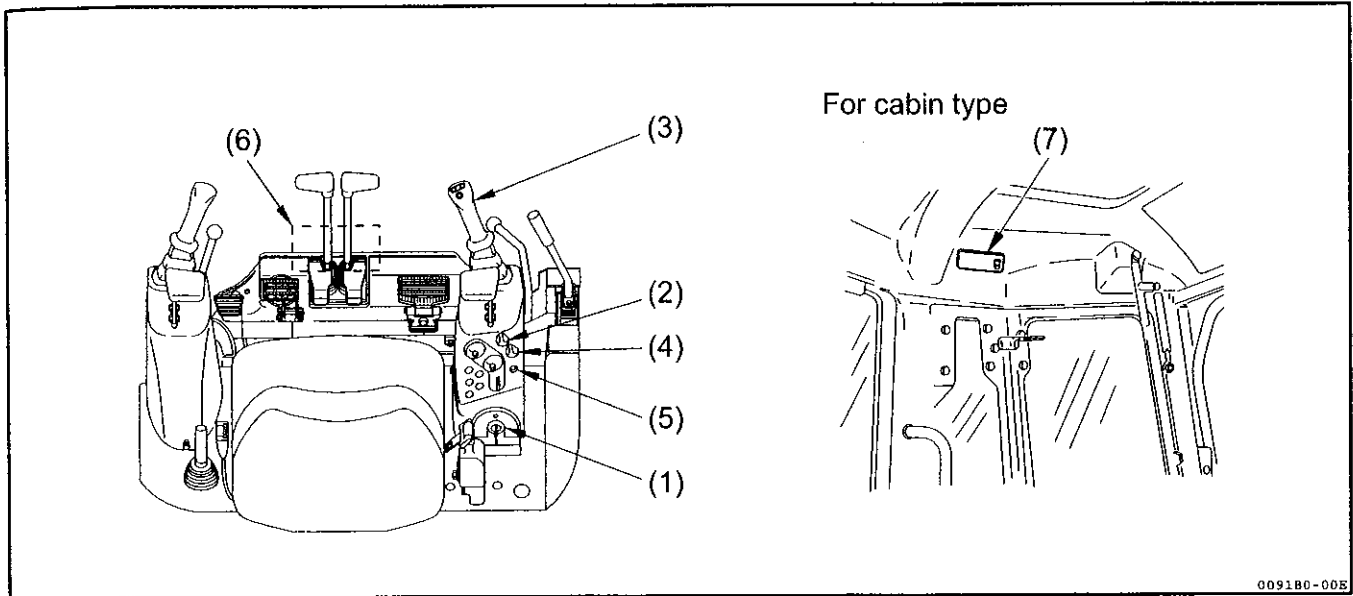
**(1) Starter switch**

Use this switch to start and stop the engine.

- OFF position  
Turn the key to "OFF" to stop the engine and disconnect electrical circuit or remove the key.
- ON position  
Turn the key to "ON" to connect the electrical fuel solenoid circuit and the electrical charging circuit. (Keep the key in this position while running the engine.)
- START position  
Turn the key to "START" to start the engine. Release the key after the engine is started and it will return to the "ON" position.
- HEAT position  
Turn the key to activate the preheating circuit and warm up intake air to start the engine easier in cold weather. (Set the key to this position when the outside temperature is low.)
- When the engine is not running and the switch is in the "ON" position, the buzzer keeps sounding.  
Turn the switch to the "OFF" position to stop sounding.

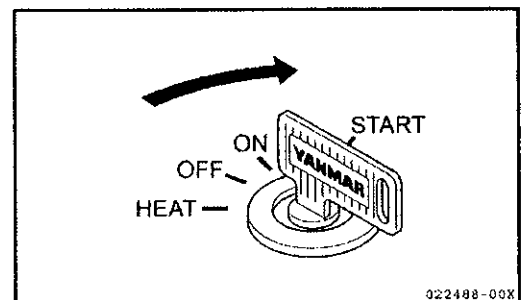

### 13. Description of Control Devices

#### (2) Light switch

The boom light and the headlight go on when the switch is turned on with the starter switch set to the "ON" position.

- ON : The lamps go on.
- OFF : The lamps go off.

#### **IMPORTANT**

**Do not keep on the lamps on for a long time while the engine is not running. The battery runs down and the engine cannot be started.**

#### (3) Horn switch

Press the switch on the top of the right control lever to sound the horn.

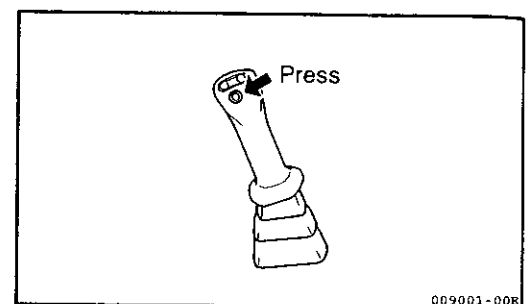
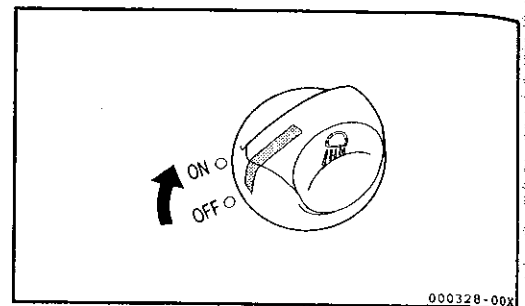

#### (4) Wiper and windshield washer switch (for cabin)

This switch serves both wiper switch and windshield washer switch.

##### 1) Wiper switch

Move the switch to the "ON" position to actuate the wiper of the windshield.

- ON : Wiper works.
- OFF : Wiper stops.

##### 2) Windshield washer

Push the wiper switch.

The windshield will be sprayed with windshield washer fluid.

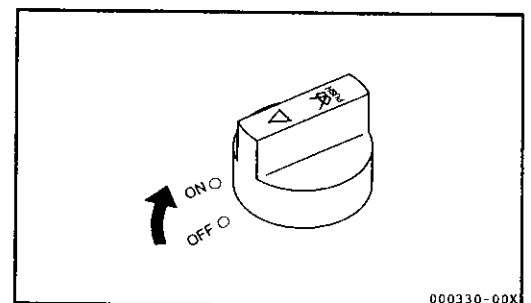

#### **IMPORTANT**

- **Do not push the switch when the tank is empty.**  
It could cause pump failure.
- **Wiping the dry windshield could damage the glass.**  
Use the wiper only when the windshield is wet.
- **The wiper blade may freeze in cold weather. Do not attempt to move it; otherwise the wiper motor will be damaged.**

**(5) Heater switch (for cabin)**

Use this switch to warm up the air in cabin. Move the switch to select fan speed. The heater switch allows you to select a high or low draft volume by setting it as follows:

- LO : Low fan speed.
- HI : High fan speed.
- OFF : Off.

Operate the heater switch after the cooling water has warmed up.

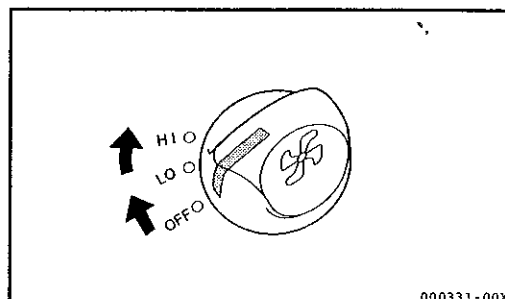
**(6) Travel alarm switch**

When the travel levers are pushed or pulled, the travel alarm switches are turned on and alarm sounds.

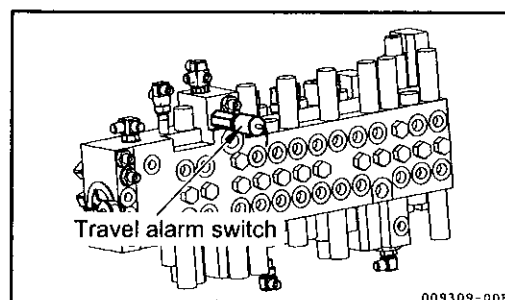
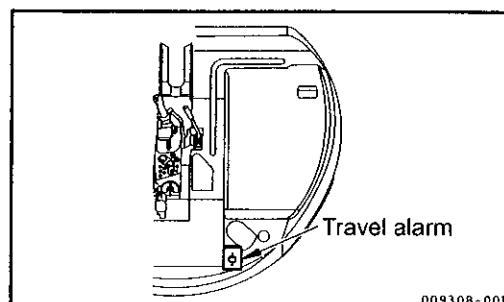
**(7) Room lamp switch (for cabin)**

The room lamp goes on when the switch is turned on with starter switch set to "ON" position.

- ON : The lamp goes on.
- OFF : The lamp goes off.

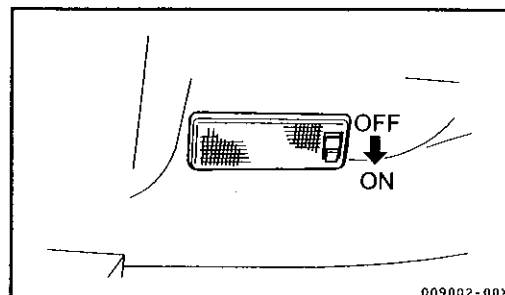

## 13. Description of Control Devices

### 13-3. Control levers and pedals

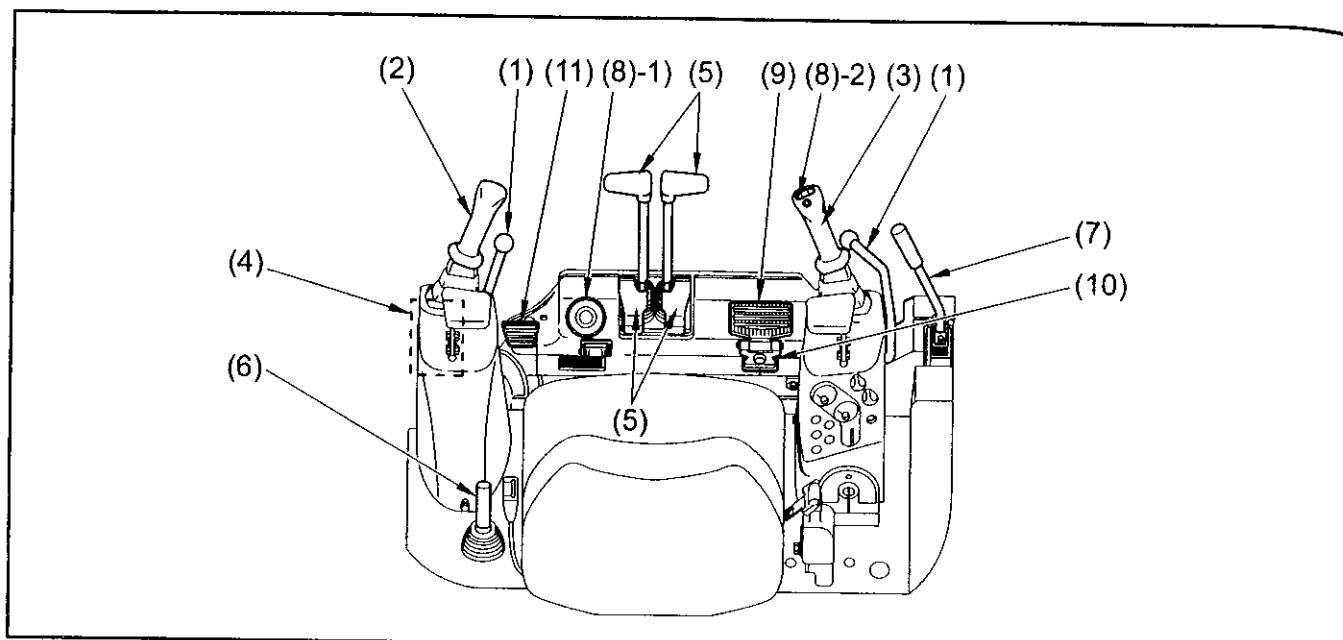

009181-00X

#### (1) Lock levers (for implement control levers on both sides and travel lever)

The lock levers lock the implement control and travel levers. When pulling the left lock lever back, the control lever stand (L) comes up. While the control lever stand (R) does not come up when pulling the right lock lever back.

### **⚠ WARNING**

- When leaving the operator's seat, be sure to put the bucket on the ground and move the lock levers to the lock positions. Keep in mind that if you should touch the unlocked lever inadvertently, a serious accident could occur.
- Be sure to place the lock levers securely in position. If not, they could come out of the lock position. Thus always make sure that the lock levers are in position as illustrated in the right figure.
- When pulling the lock levers back, be careful not to touch the implement control lever.
- Remember that if the lock levers are not pulled back fully, the implement will not be locked.

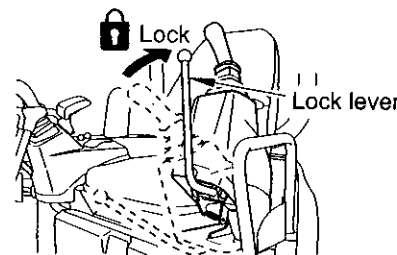

(Left side) 008999-00Z

#### IMPORTANT

The machine uses a hydraulic lock system. If the lock levers are in the lock position, all the hydraulic cylinders for the boom, arm, bucket, blade and an actuator in the P.T.O. circuit as well as the swing and travel motors will not activate although the right and left implement control levers and the P.T.O. switches are free to move.



**! WARNING**

When pushing the lock levers down forward, be careful not to touch the implement control lever.

**! WARNING**

The relationship between the control lever shift configuration and the implement movement is detailed in this manual. To prevent an accident due to operational error, therefore, the hydraulic system must not be modified by reconnecting the hydraulic hoses and valves.

**(2) Control lever (L)****(3) Control lever (R)**

Use these levers to control the implements and swinging of upperstructure.

Refer to Section "14-8. Operating the implements".

**(4) 2 way valve**

STD : ISO pattern

OPT : OPT pattern

Refer to Section "14-8. Operating the implements".

- 1) Stop engine and make sure the lock lever is in lock position.
- 2) Open the cover.
- 3) Unlock the selector handle to move it to "STD" or "OPT" position.
- 4) Securely lock the selector handle.
- 5) Close the cover.

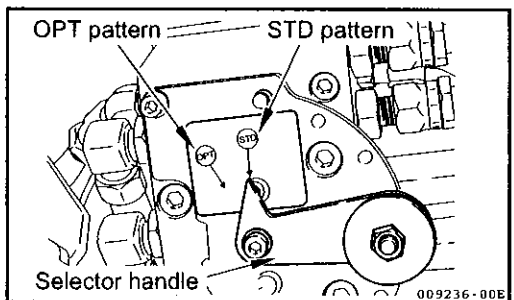
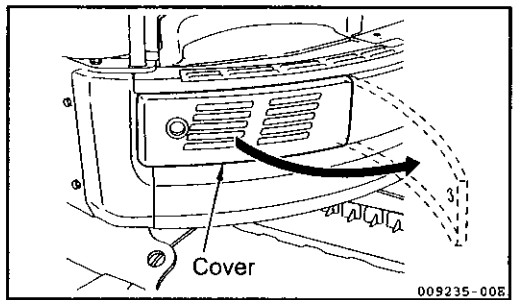
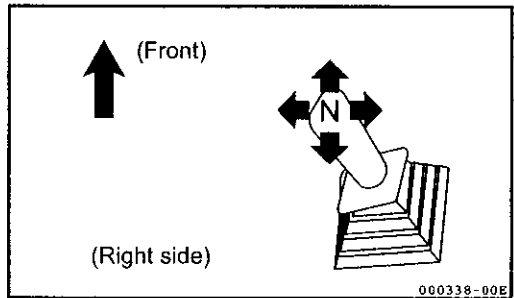
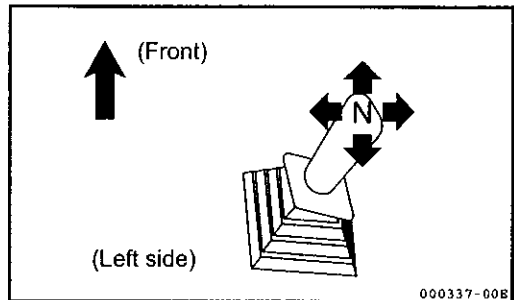
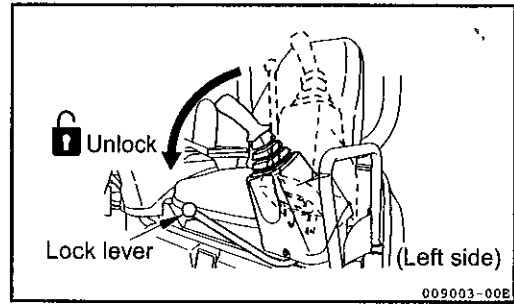

### 13. Description of Control Devices

#### (5) Travel levers and pedals

The travel levers and pedals control the traveling of the machine.

#### **⚠ WARNING**

- If the blade is in the reverse direction, the travel levers and pedals should also be operated in reverse for forward and backward travel.
- When operating the travel levers and pedals, you must check to see if the blade is in the normal position or in the reverse position. Note that the blade is in the normal position when the sprocket is in the rear.

Refer to Section "12-1. Overview of the machine".

When the blade is in the normal position:

Forward : Push the travel levers forward.

Step on the front of the pedals.

Reverse : Pull the travel levers backward.

Step on the rear of the pedals.

N : Neutral...The machine stops.

#### (6) Accelerator lever

The accelerator lever controls the engine speed (output).

(A) Idling : Push the lever forward fully.

(B) Run : Pull the lever backward fully.

#### (7) Blade lever

Use this lever to control the blade.

#### IMPORTANT

The blade lever is not locked by setting the lock lever to the lock position. Do not touch the blade lever when not operating the blade.

(A) : Down : Push the lever forward.

(B) : Up : Pull the lever backward.

N : Neutral...When released, the lever will return to the neutral position and the blade is held as it is.

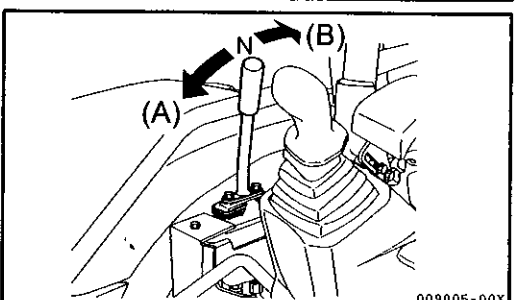
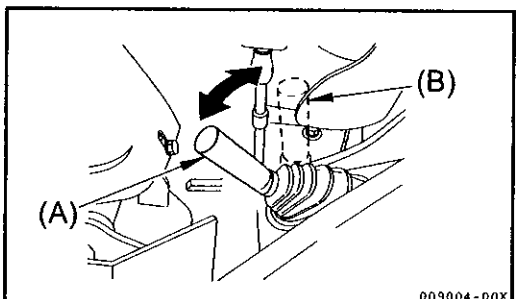
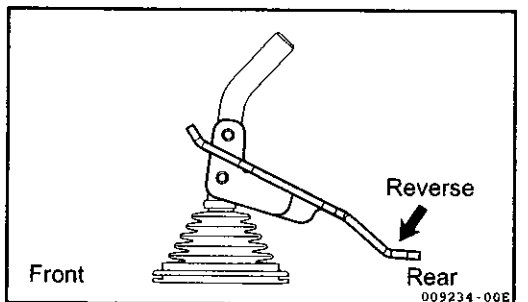
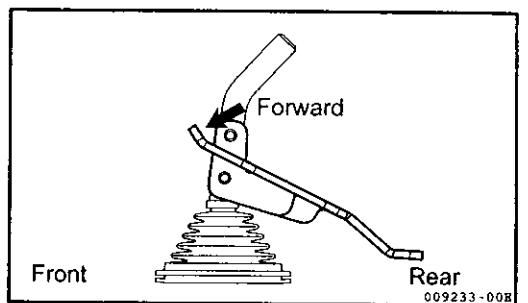
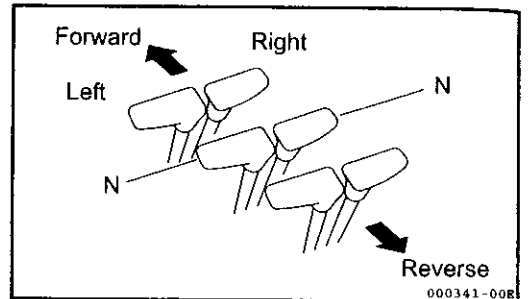
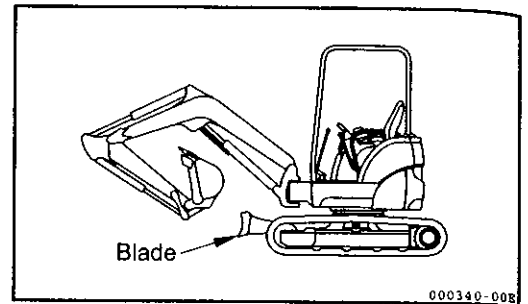

**(8) P.T.O. switches**

1) Foot switch

Unfold the foot rest and press the foot switch to operate a single acting attachment.

2) Lever switch

Use this switch to control the attachment.

- Single acting attachment (hammer)

Operate the lever switch with pressing the foot switch.

- Double acting attachment (tilt bucket, auger, etc.)

Operate the lever switch only.

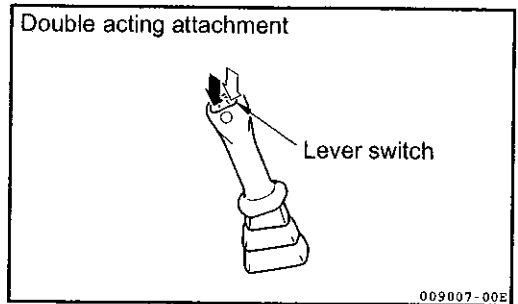
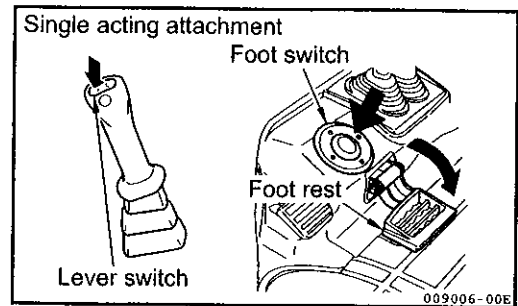

**(9) Boom swing pedal**

Use this pedal to swing the boom to right and left after unfolding it flat.

(A) : Swing right : move to the right

(B) : Swing left : move to the left

N : Neutral...When released, the pedal will return to the neutral position and the boom is held as it is.

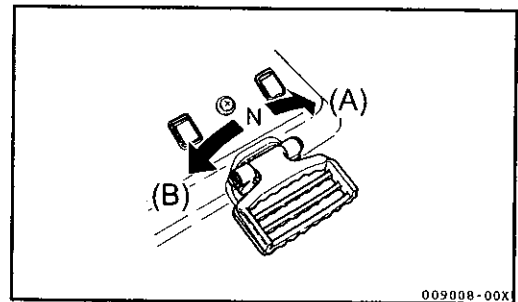

**(10) Boom swing pedal lock**

Fold the pedal to lock it.

**⚠ WARNING**

To avoid bodily injury, securely place the pedal in the lock position when the boom swing pedal is not being operated.

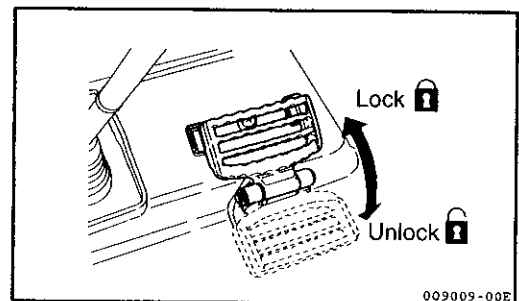

Placing the pedal in the lock position locks the boom swing pedal.

To prevent misuse, always set the pedal in the lock position when the boom swing pedal is not being operated. The pedal in the lock position can be used as a foot rest.

**(11) High-speed pedal**

Step on this pedal to control the travel speed. Step on the pedal while the travel levers are in operation to increase the travel speed.

**IMPORTANT**

Do not travel at high speed for many hours.

Do not step on the pedal while operating the blade.

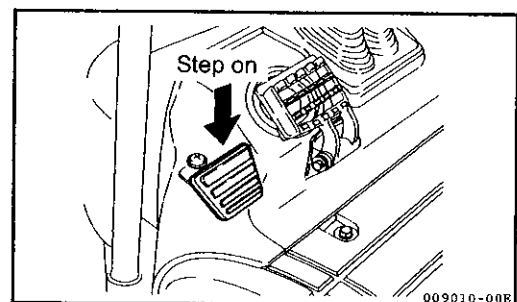

## 13. Description of Control Devices

### 13-4. Engine hood B

#### (1) Opening the engine hood B

- 1) Insert the starter switch key and turn counterclockwise to unlock.
- 2) Pull the engine hood B lever to release the lock, and then the engine hood B opens.
- 3) The engine hood B fully opens to be locked with the stopper.

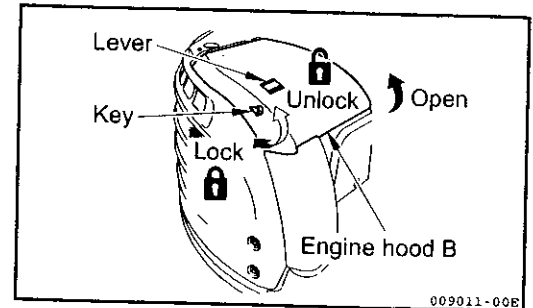

#### (2) Closing the engine hood rear cover

- 1) Close the engine hood B and press it down fully until it clicks.
- 2) Turn the starter switch key clockwise and engage the lock.

### 13-5. Engine hood rear cover

#### ⚠ WARNING

Do not open the engine hood while the engine is running. Rotating fan and fan belt and high temperature components can cause personal injury. Check and service the inside of the engine hood after the engine stops.

#### (1) Opening the engine hood rear cover

- 1) Insert the starter switch key and turn counterclockwise to unlock.
- 2) Pull the engine hood rear cover lever to release the lock, and then the engine hood rear cover opens.
- 3) The engine hood rear cover fully opens to be locked with the stopper.

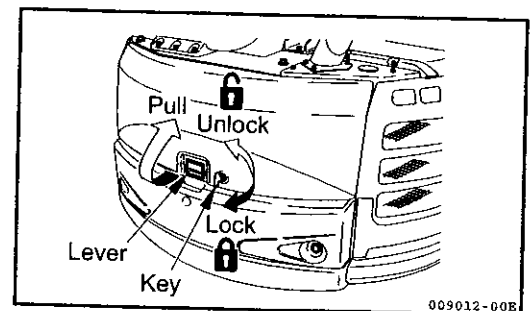

#### (2) Closing the engine hood rear cover

- 1) Lift up the engine hood rear cover slightly and pull the rod to disengage the lock.
- 2) Close the engine hood rear cover and press it down fully until it clicks.
- 3) Turn the starter switch key clockwise and engage the lock.

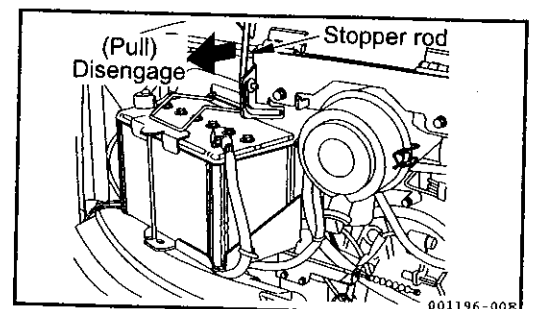

**13-6. Storage space for the operation & maintenance manual**

Storage space for the operation and maintenance manual is under the operator's seat.

Pull the lever and open the cover.

Press the cover until it clicks when closing.

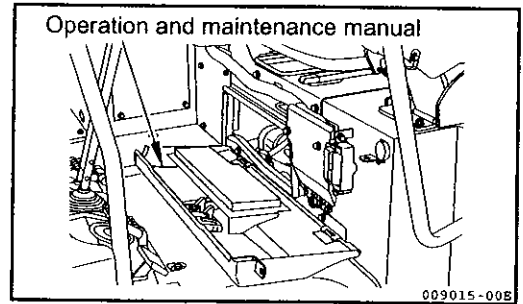
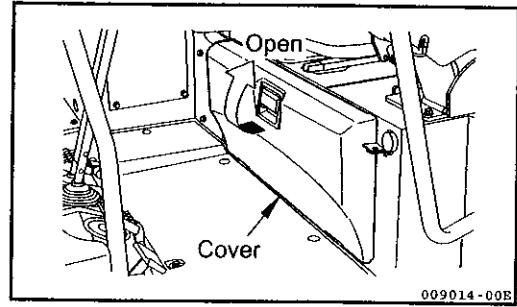

13-7. Windshield (for cabin)

**⚠ WARNING**

- To avoid bodily injury while operating the machine, make sure the door and windshield are locked in either the open or shut position.
- When the side door or the windshield is opened and it is not securely locked, it may be closed suddenly on impact during operation. It may cause bodily injury : for example, your hands are put between the door or the windshield and the cabin frame or your head is hit against them.
- Do not put your hand or head out of the opened side door or windshield. When opening the side door or the windshield, lock it securely.

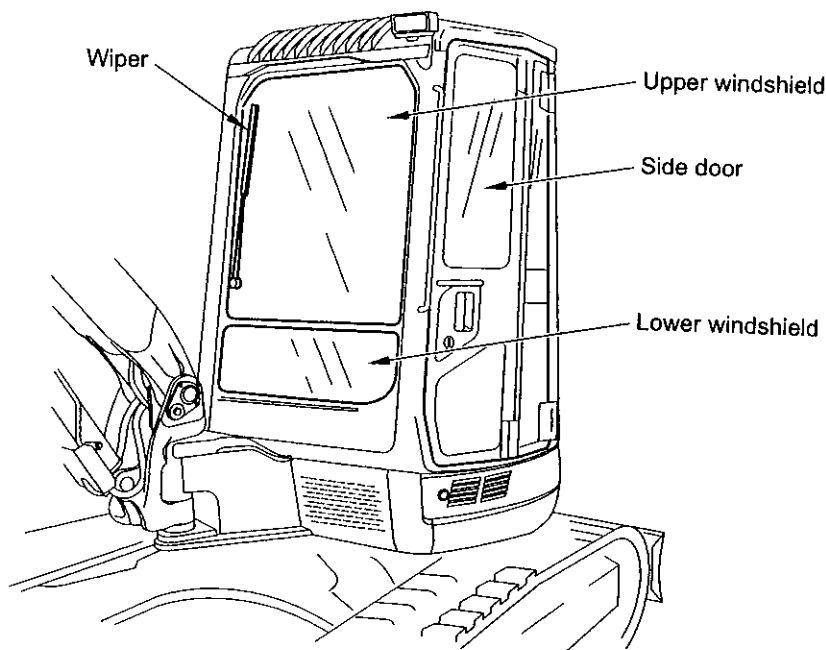

009016-00E

**⚠ WARNING**

Both the upper and lower windshields can be opened and closed.  
When housing or closing the upper and / or lower windshields, they may get down suddenly. To prevent this, lock them securely with the lock levers.

## ⚠ WARNING

- To avoid bodily injury, securely grasp the handles with both hands when opening and closing the windshield.
- Securely lock the windshield using the lock levers and the window locks when storing or closing the upper and lower front windshields.
- When opening or closing the front windshield, be sure to place the lock levers securely in the lock position.

### ■ Opening the upper windshield

- 1) Hold the handles with your hands and turn the right and left lock levers (A) to the arrowed direction to release the lock.
- 2) Slide the windshield to the upper rear side while pulling it to this side.
- 3) Lock the upper windshield housed under the ceiling securely with the right and left lock levers (A).

### ■ Closing the upper windshield

- 1) Hold the handles with your hands and release the right and left lock levers (A).
- 2) Holding the handles, lower the upper windshield slowly.
- 3) Lock the upper windshield securely with the right and left lock levers (A).

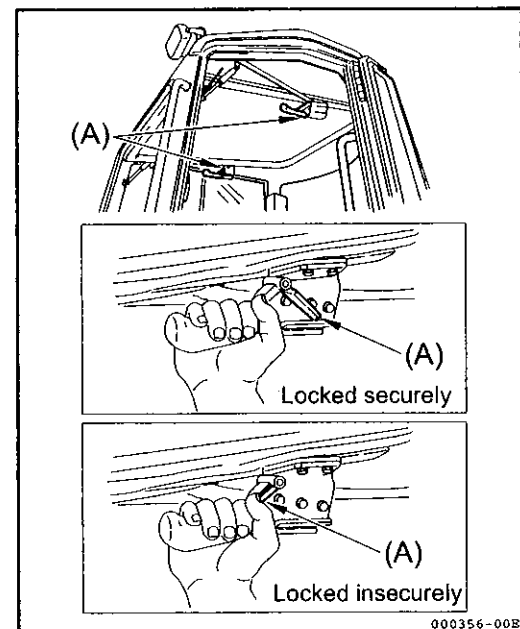
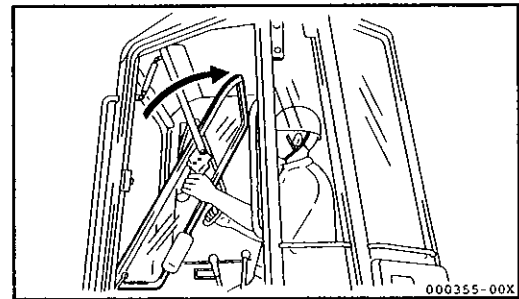
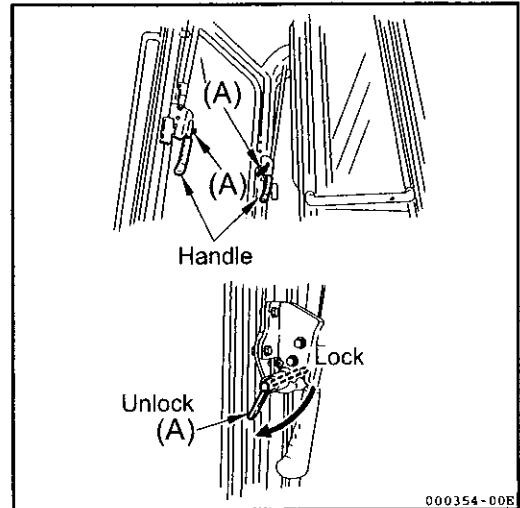
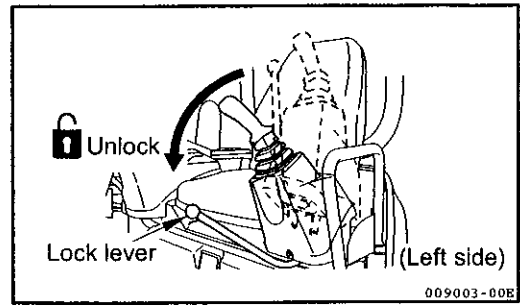

### 13. Description of Control Devices

#### ■ Opening and closing the lower windshield

## ⚠ CAUTION

Open and close the lower windshield after housing the upper windshield.

- 1) Hold the lower windshield with both hands to lift it up.
- 2) Put the lower windshield in the storage area on the rear left of the cabin.
- 3) Lock the lower windshield securely by pressing it against the window locks (D).
- 4) Push the upper side of each window lock (D) to remove the windshield put in storage.

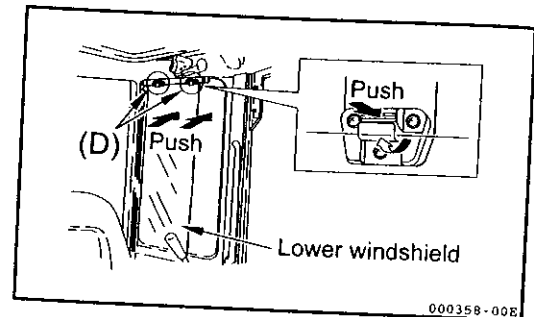
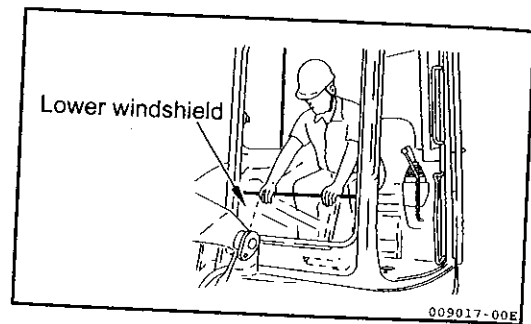

#### 13-8. Operator's seat

## ⚠ WARNING

- Be sure to adjust the seat slide to obtain the best operating position whenever you start operation or a new operator begins to operate the machine.
- Do not place any objects within the moving area of the operator's seat.
- Do not adjust the operator's seat while operating the machine.

Adjust the seat so that the operator can easily operate the control levers in good posture.

#### ■ Seat position control adjustment (forward and backward)

Pull the slide lever (A) under the seat upward to slide the seat forward or backward.

The adjustable amount of the seat for forward and backward sliding is 2.95 in. (75 mm)

And the seat can be adjusted at any of the five levels within 2.95 in. (75 mm)

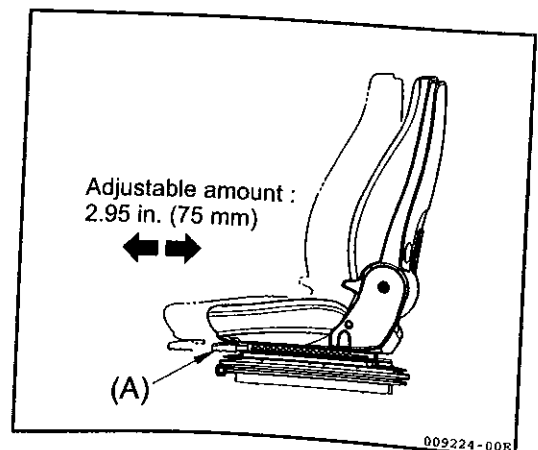



■ **Weight adjustment (Except air conditioner spec. type)**

1) The seat can be adjusted for the operator's weight by turning the weight adjuster lever (B) with the seat empty.

The setting weight can be read at the indicator (C).

2) Turn the weight adjuster lever (B) clockwise the setting weight is increased.

3) Turn the weight adjuster lever (B) counterclockwise, the setting weight is decreased.

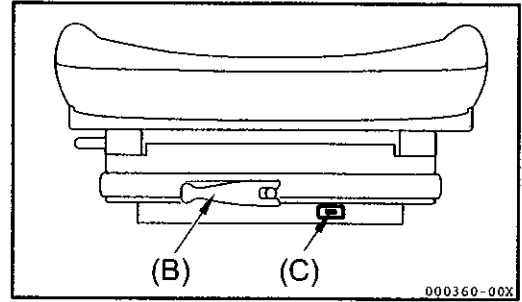

**13-9. Ash tray (for cabin)**

**⚠ WARNING**

**Do not place any combustible matter in the ash tray.**

Open the ash tray by pulling the lid to use it. Be sure to close the ash tray lid when it is not in use.

To empty and clean the ash tray, lift it up by holding both ends.

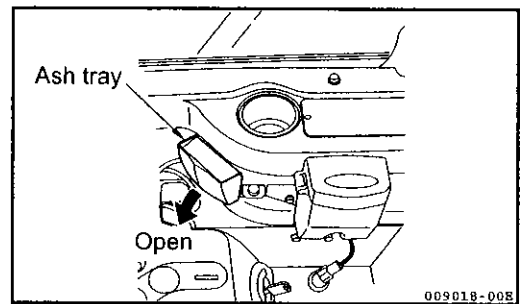

**13-10. Headlight**

**⚠ WARNING**

**The headlight gets hot when it is turned on. Do not touch it carelessly with your bare hand to prevent burns.**

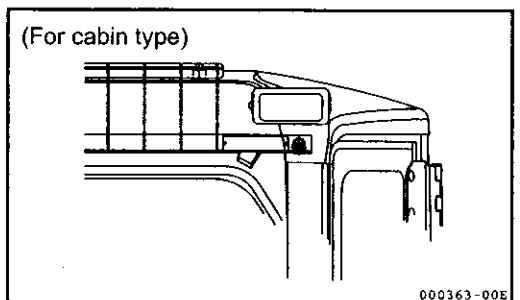
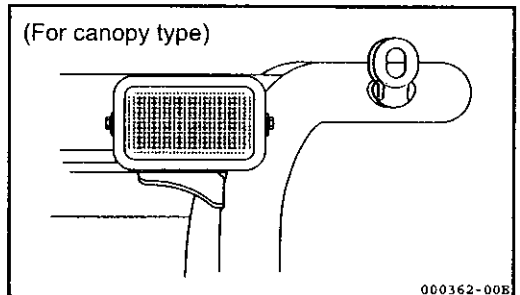

### 13. Description of Control Devices

#### 13-11. Air outlet (for cabin)

The wind direction is adjusted by changing the grille direction.

Move the grille to the desired position with a knob in the center of the grille.

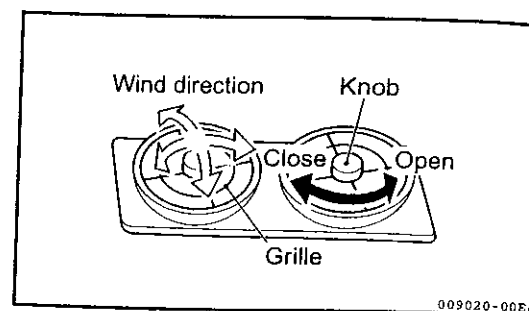
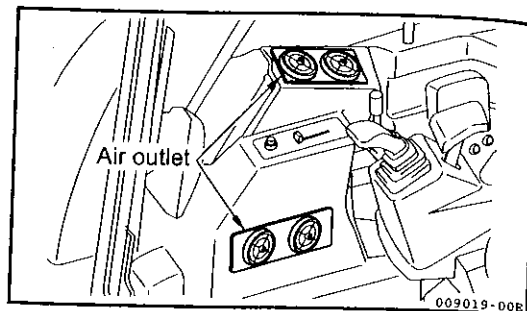

#### 13-12. Right window glass (for cabin)

Open the right window glass in the arrowed direction.

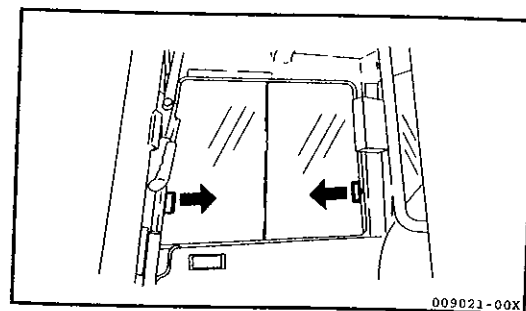

### 13-13. Cabin side door

#### 13-13-1. Opening and closing the cabin side door

(1) From outside.

- 1) Turn the starter switch key counterclockwise to unlock the side door.
- 2) Pull the outer handle to this side to open the side door.
- 3) Close the side door and turn the key clockwise to lock to door.

(2) From the inside.

- 1) Pull the inner handle to this side to open the side door.

#### 13-13-2. Door lock

The door lock is used to hold the side door open.

- 1) Press the side door into the lock section to hold it open.
- 2) Press the lever (1) on the left side of the seat down to release the locked side door.

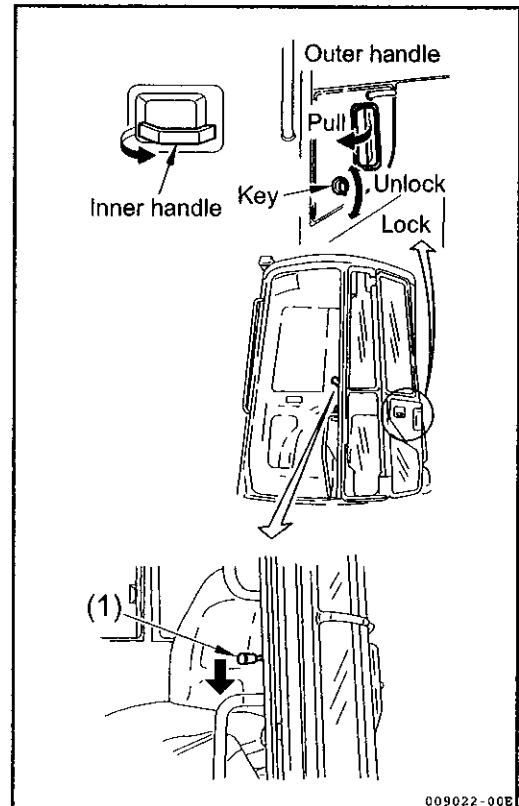

### 13-14. Replenishment of windshield washer fluid

- 1) Add windshield washer fluid, if necessary, to the reservoir.

#### ⚠ CAUTION

- When you add the reservoir with windshield washer fluid, take care not to enter dust into the reservoir.
- Determine the mixing ratio of the windshield washer fluid to water on the basis of the lowest past temperature

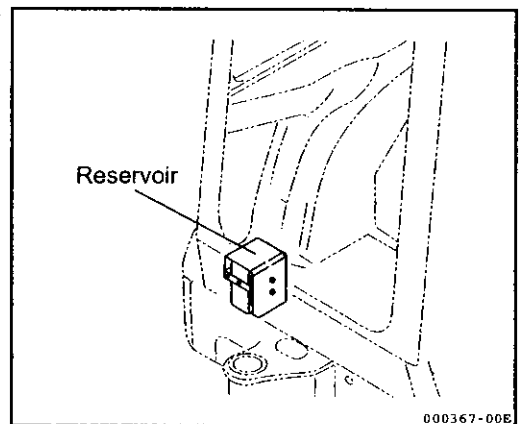

# 13. Description of Control Devices

## 13-15. Fuse

### ⚠ CAUTION

- When replacing the fuse, be sure to turn off the power by setting the starter switch at the OFF position.
- Using a wire, aluminum foil or the like instead of the fuse could cause burnouts of the gauges, the electrical equipment and the wiring due to overheating.
- If a new fuse is blown out immediately after replacement, there may be a problem with the electrical system. Ask the nearest dealer for check and service.

The fuse protects the electrical equipment and wiring from becoming overheated. If the fuse is corroded with white deposits or if the fuse is loose in the holder, the fuse must be replaced with a new one.

#### ■ Position of the fuse box

Blade fuse

It is installed on the front left of the sheet mount.

Slow-blow fuse

It is installed by the battery inside the engine hood rear cover.

#### ■ Replacing the fuses

If the electrical equipment does not operate, the fuse may have been blown out. Follow the procedure below:

- 1) Set the starter switch at the "OFF" position.
- 2) Remove the fuse box cover.
- 3) If the fuse is blown out, replace it with a spare fuse of rated capacity.

Symbol	Fuse capacity	Circuit name
A	15 A	<u>Room lamp</u> , <u>Window washer</u> , Quick coupler, <u>Heater</u> , <u>Air conditioner</u>
B	30 A	<u>Air conditioner</u>
C	15 A	Horn, <u>Head lamp</u> , Monitor light, Boom lamp, 2-speed travel valve, Cab or Canopy lamp
D	15 A	<u>Wiper</u> , <u>Heater relay</u>
E	15 A	Timer, Safety relay, Generator, Fuel feed pump, Engine stop solenoid
F	15 A	Indicator box, Buzzer, Cut-off valve, Travel alarm
G	5 A	<u>Radio</u> , Controller
H	5 A	Spare
I	30 A	
J	15 A	

The oblique character parts:

Applicable to models with the relevant equipment.

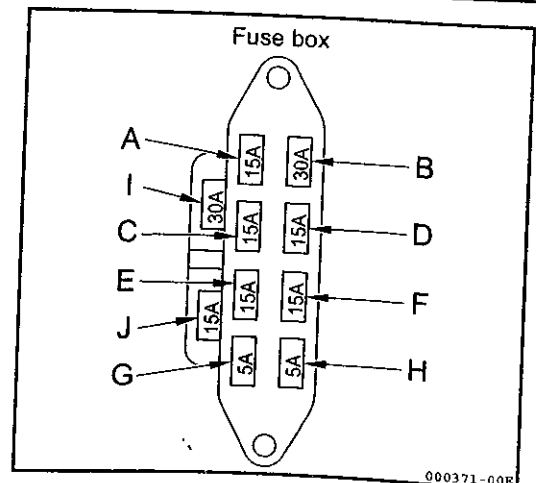
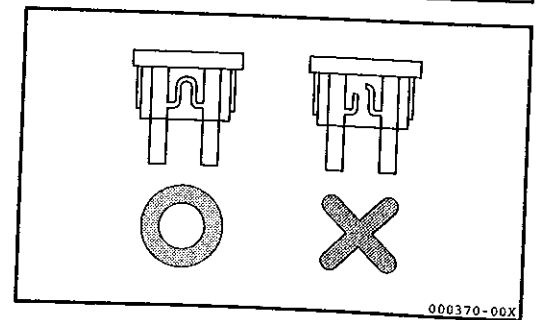
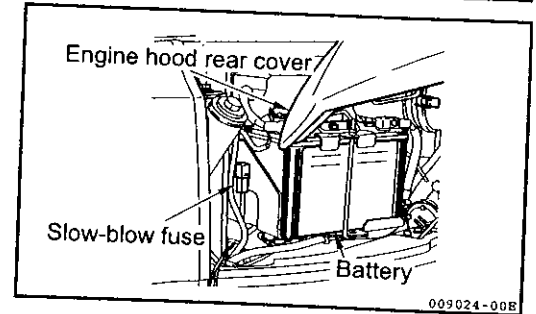
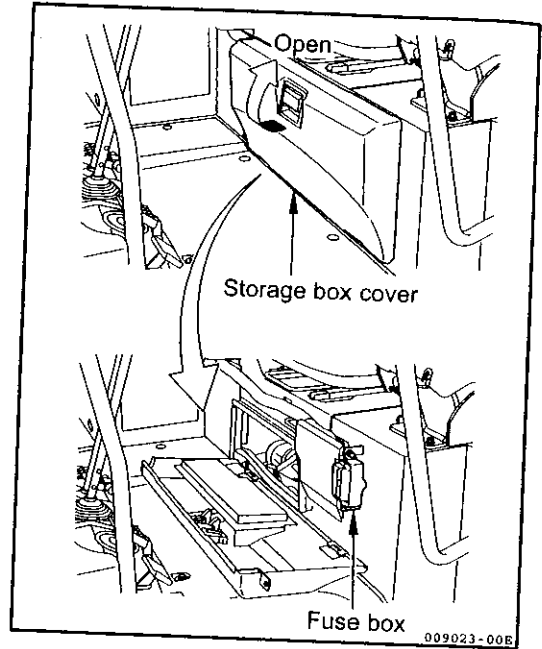

## 14. Operating Instructions

### 14-1. Checking before starting the engine

#### 14-1-1. Walking check (visual inspection) around the machine

#### **⚠ WARNING**

- If there are any combustibles in any heat build-up areas, or if there are any fuel and/or oil leaks, a fire can result.
- Check for possible fire causes carefully. If there is anything abnormal, be sure to take corrective action or contact your dealer.

Before starting the engine, visually check the outside and underside of the machine as follows: Check bolts and nuts for loose connections; check the fuel, oil, and water for leaks; and also check the implement and the hydraulic system to see that they are operating properly. In addition, check the electrical wiring for loose connections and for dust deposits in the heat build-up areas. Check the following points before initial start-up for the day.

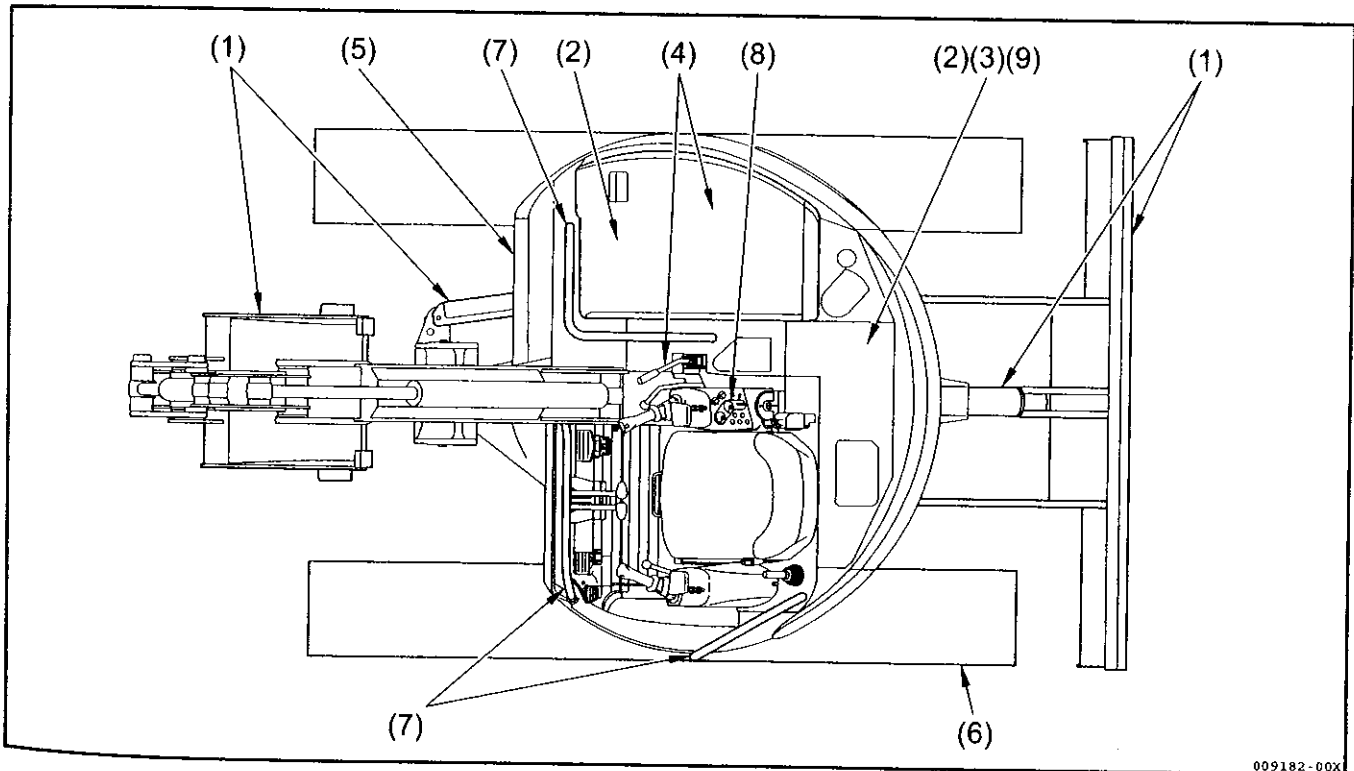

#### **(1) Checking the implement, hydraulic cylinders, linkages, and hoses for damage, wear and loose connections**

Check the implement, hydraulic cylinders, linkages, and hoses for damage, wear and loose connections. If any abnormality is found, take corrective action.

## ***14. Operating Instructions***

---

### **(2) Removing dust deposits from around the engine, battery, and radiator**

Check that there are no dust deposits around the engine or on the radiator, and that there are no combustibles (dead leaves, twigs, etc.) in the heat build-up areas, such as the engine muffler, or around the battery. If there are any, remove them.

### **(3) Checking the engine and its accessories for oil or water leakage**

Check the engine for oil leakage and the cooling water system for water leakage. If oil or water leakage is found, take a corrective action.

### **(4) Checking the hydraulic system, hydraulic oil tank, hoses, and joints for oil leakage**

Check for oil leakage. If oil leakage is found, take corrective action.

### **(5) Checking the grease piping for grease leakage**

Check for grease leakage or ooze. If grease leakage or ooze is found, take corrective action.

### **(6) Checking the undercarriage (tracks, sprockets, and idlers) for breakage, wear, loose bolts, and oil leakage around the rollers**

If any breakage or wear is found, correct it. Retighten the bolts if necessary.

If oil leakage is found, take corrective action.

### **(7) Checking the handrails and steps for breakage and loose bolts.**

If any breakage is found, take corrective action. Retighten the bolts if necessary.

### **(8) Checking the gauges and the monitor for breakage and loose bolts**

Check the gauges and the monitor for breakage and loose bolts. If any abnormality is found, replace the gauge or the monitor with a new one, or retighten the bolts if necessary. Clean the surfaces of the gauges and monitor.

### **(9) Checking the fuel filter to see whether the red ring has sunk down at the cup bottom**

If the red ring has sunk down at the cup bottom, no water has mixed into the oil; if the red ring is floating in the cup, water is mixed into the oil under the red ring. In this case, take out the cup to remove the water.

**14-1-2. Checking before start-up**

Check the following points before initial start-up for the day.

■ **Checking and replenishing the cooling water**

**⚠ WARNING**

- Do not remove the fill cap from the radiator unless refilling the coolant.
- Check the coolant water level in the sub-tank when the engine is cool.

- 1) Open the engine hood rear cover. Then check that the cooling water level in the sub-tank (1) (illustrated in the right figure) is between the FULL and LOW marks. If the water level is below the LOW mark, refill the sub-tank up to the FULL mark through the water supply port of the sub-tank (1).

For the quality of cooling water to be used, refer to Section "23. Fueling, Oiling and Greasing Based on Temperature Range".

- 2) After replenishing, securely tighten the radiator cap.
- 3) If the sub-tank is empty, check it for water leakage, and then, check the water level in the radiator.  
If the water level is low, refill the radiator first, then refill the sub-tank.
- 4) If the cooling water level is appropriate, close the engine hood rear cover.

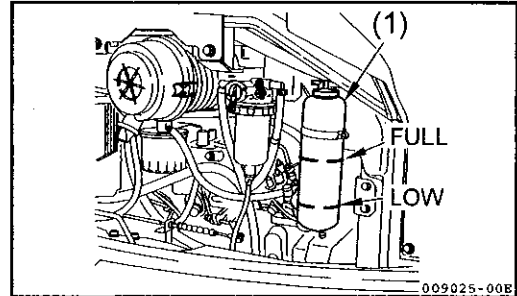

## 14. Operating Instructions

### ■ Checking and replenishing the engine oil

#### ⚠ WARNING

- At operating temperature, oil and dipstick areas are hot.  
Do not allow hot oil or components to contact skin to prevent bodily injury.
- Check oil level and refill oil after engine has cooled down.

- 1) Open the engine hood rear cover and securely lock it with the stopper.
- 2) Pick up the dipstick (G) and wipe it with a rag to remove oil deposits.
- 3) Insert the dipstick (G) into the dipstick tube fully, then draw it out.
- 4) If the dipstick (G) is wet above the midpoint between the H and L marks, the engine oil level is appropriate. If the oil level is below the midpoint between the H and L marks, supply engine oil through the oil supply port (F). For the quality of the engine oil to be used, refer to Section "23. Fueling, Oiling and Greasing Based on Temperature Range".
- 5) If the engine oil level is above the H mark, remove the excessive amount of oil through the drain plug (P), then recheck the engine oil level.
- 6) After verifying that the amount of engine oil is appropriate, securely retighten the oil supply port cap and close the engine hood rear cover.

#### Note :

When checking the engine oil level after starting up the engine, stop the engine and allow more than 15 minutes for the engine to cool down.

If the machine is slanted, reposition the machine to ensure it is level before checking the engine oil level.

Keep in mind that the excess engine oil must not be disposed of on the ground or the road.

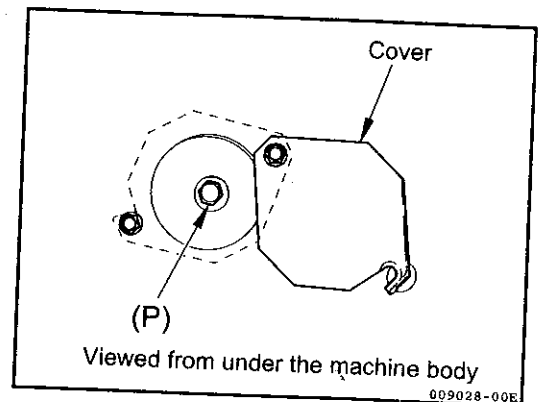
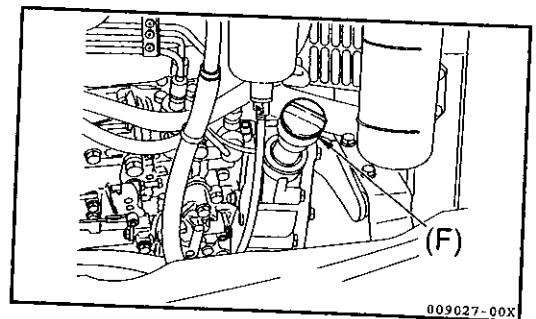
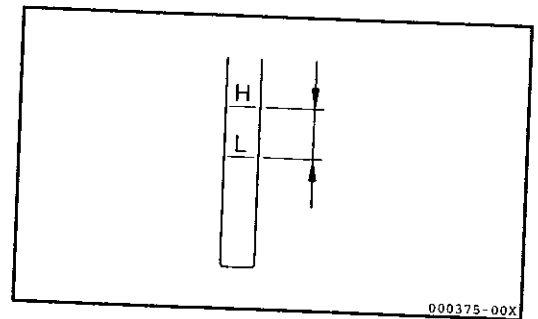
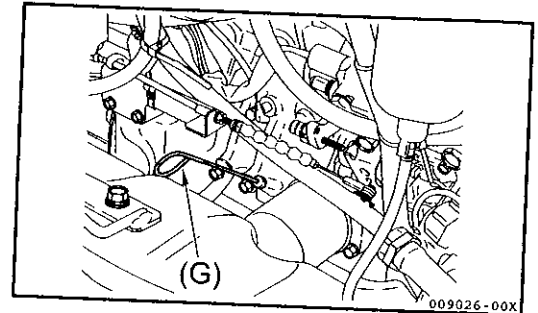



## ■ Checking the fuel level in the fuel tank and refueling

### ⚠ WARNING

Be careful not to overfill the fuel tank because it could cause a fire. If the tank is overfilled, completely wipe off the spilled fuel.

### ⚠ CAUTION

- Do not remove the strainer from the fuel supply port of the fuel tank to refill the tank.
- Be careful not to allow water settled at the bottom of the fuel container or dirt on refueling equipment to enter into the fuel tank.

- 1) Turn the starter switch to the "ON" position, and check the fuel level with the fuel gauge. Open the engine hood B, and supply fuel from the fuel supply port while checking the level gauge.

When the fuel gauge pointer indicates "E", approximately 3 Gals. (12 L) of fuel is left in the tank.

Capacity : 16.9 Gals. (64 L)

For the quality of the fuel to be used, refer to Section "23. Fueling, Oiling and Greasing Based on Temperature Range".

- 2) After refueling, securely retighten the fuel supply port cap, and close the engine hood B.

#### Note :

If the breather hole (1) in the cap is clogged, the pressure in the tank may decrease and the fuel may not be supplied adequately to the engine. Clean the engine breather hole from time to time.

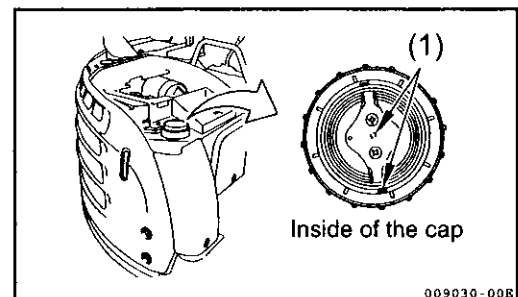
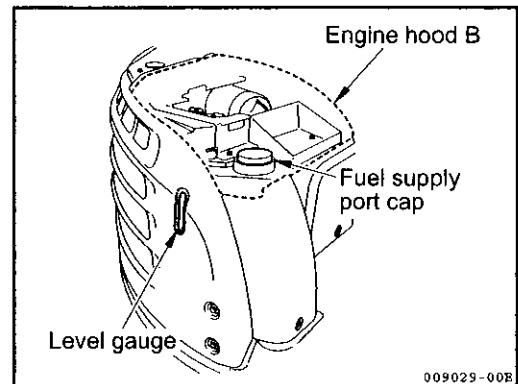
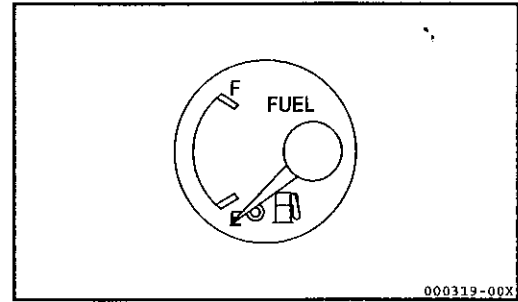

## 14. Operating Instructions

### ■ Checking and replenishing the hydraulic oil tank

#### **⚠ WARNING**

When removing the plug of the oil supply port, slowly loosen it to release the pressure in the tank to prevent a dangerous high-pressure leak.

1) Park the machine as illustrated in the right figure. When the machine is not in the posture in the right figure, start the engine, retract the bucket and arm cylinders to their stroke ends at low speed, lower the boom until the bucket teeth is placed on the ground, lower the blade to the ground, and stop the engine.

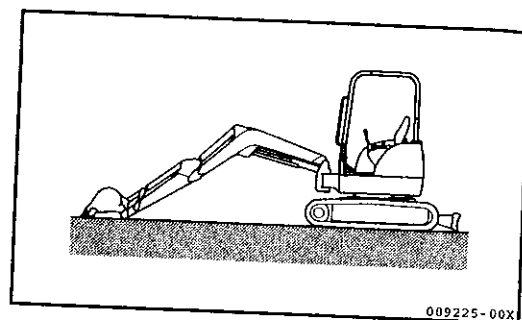

2) Check the oil level with the oil level gauge on the left side of the machine. The oil level must be between the upper and lower limit marks on the gauge.

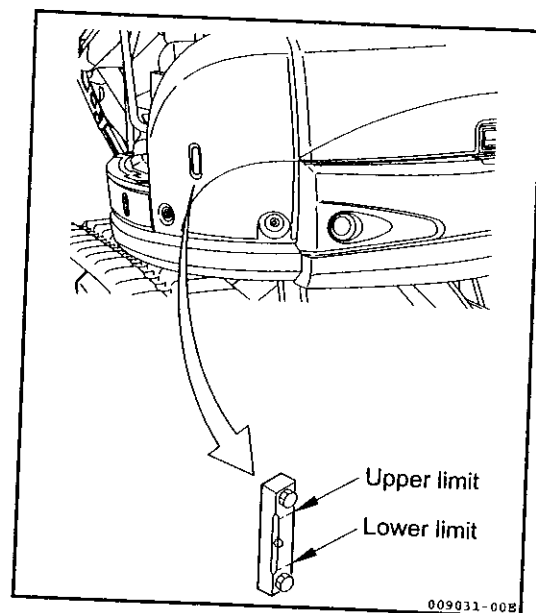

#### **IMPORTANT**

Do not replenish hydraulic oil above the upper limit mark on the oil level gauge. An excessive amount of hydraulic oil may damage the hydraulic system by placing stress on its components, causing a dangerous high-pressure leak.

3) Open the engine hood rear cover to replenish oil from the oil supply port (F) if the oil level is below the lower limit.

For the quality of the oil to be used, refer to Section "23. Fueling, Oiling and Greasing Based on Temperature Range".

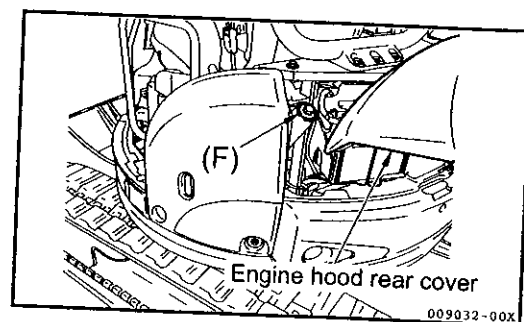

#### **Note :**

Note that the oil level varies with the oil temperature. When reading the oil level, follow these guidelines:

- Before start-up, the oil level gauge should read the level around the midpoint of the gauge scale [oil temperature : 50 to 86°F (10 to 30°C)].
- During normal operation, the oil level gauge should read the level around the upper limit mark of the gauge scale [oil temperature : 122 to 176°F (50 to 80°C)].

### ■ Checking the fan belt tension

- 1) Open the engine hood rear cover.
- 2) Press down the fan belt between the crankshaft pulley (1) and the generator pulley (2) with a finger to check the fan belt tension.  
Pressing load : Approximately 22.1 lbs. (10 kgf)  
Adequate slack : 0.39 to 0.59 in. (10 to 15 mm)
- 3) Adjust the tension if necessary.  
Refer to Section "27-6. Maintenance every 250 service hours" for the adjustment procedure.
- 4) When the tension is proper, close the engine hood rear cover.

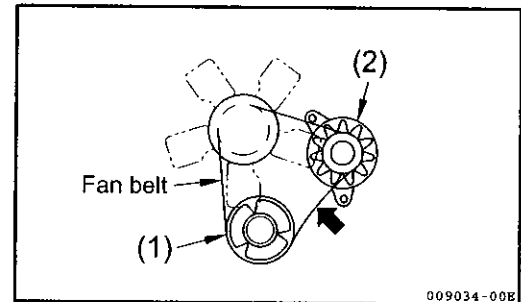
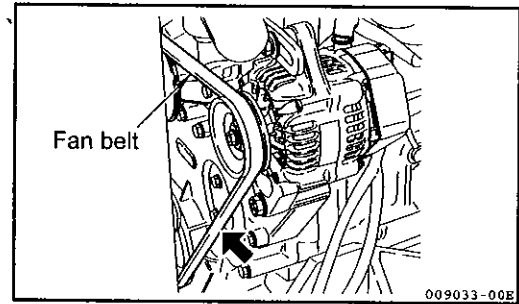

### ■ Checking and replenishing the battery electrolyte

#### ⚠ DANGER

- The battery generates flammable gas and can cause a fire and an explosion. Keep sparks, flames and lit cigarettes away from the battery.
- Battery electrolyte is strong acid. To avoid serious injury, do not allow the electrolyte to contact your skin or splash into your eyes.
- Always wear safety goggles and protective clothing, when adding electrolyte.
- Do not use the machine with the battery which is short of battery electrolyte. The shortage of battery electrolyte not only will reduce the life of the battery but also could cause an explosion.

- 1) Open the engine hood rear cover to check the electrolyte level. The level must be between the upper and lower level marks.
- 2) If the electrolyte level is lower than the lower level mark, replenish it.

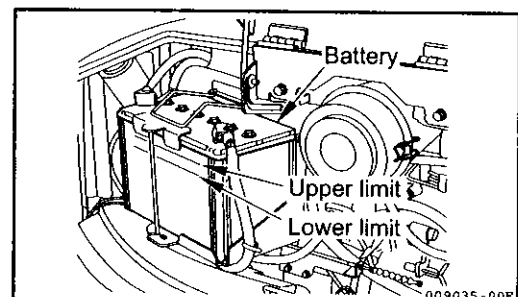

## 14. Operating Instructions

### ■ Greasing

#### IMPORTANT

Grease the fittings thoroughly after washing the machine or after operation in rain, on soft ground, or in muddy water.

- 1) Put the bucket and the blade on the ground and stop the engine.
- 2) Clean the grease nipples indicated with the arrows in the right figures and grease them using a grease gun.
- 3) After greasing, wipe off the excessive grease with waste cloth or the like.

Refer to Section "14-14-10. Maintenance" for the quick coupler.

### ■ Implement

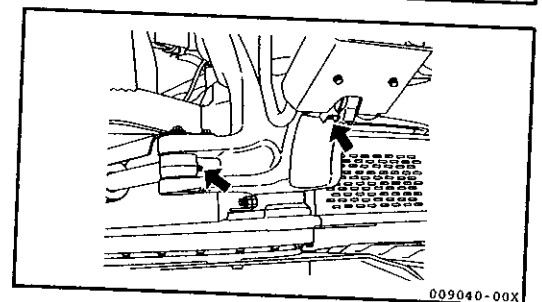
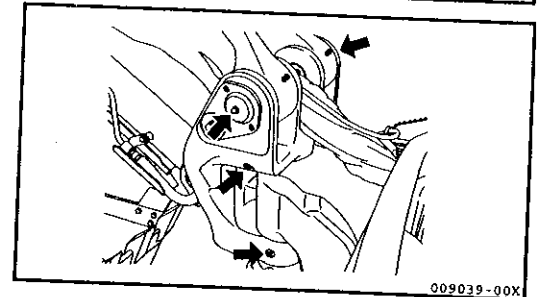
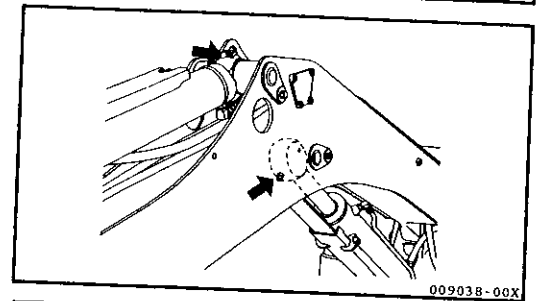
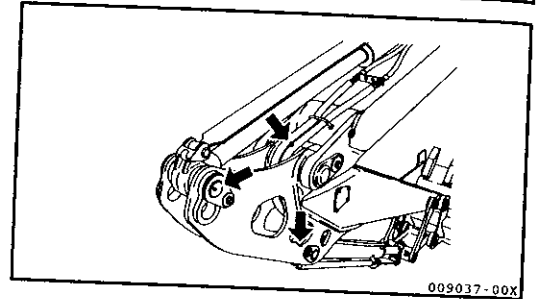
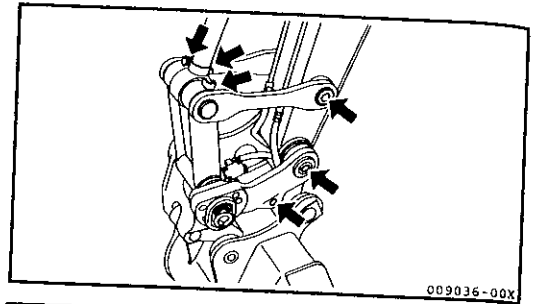

### ■ Blade

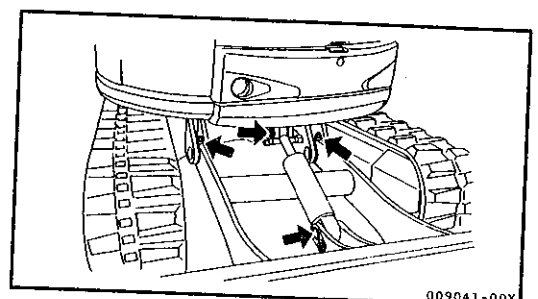

■ **Checking the electrical equipment**

**⚠ CAUTION**

**If a fuse blows out frequently, contact your dealer for assistance.**

Check fuses for damage, wiring for poor connections or short circuits, and battery terminals for corrosion or loose fits. Take corrective action.

Check the following items after the starter switch is turned to the "ON" position.

1) Check the monitor functions

- Check the fuel gauge, the water temp. meter and the hourmeter function.
- Check engine oil pressure alarm lamp, battery charge alarm lamp and water temperature alarm lamp for lighting.

2) Check that all switches function correctly and lamps light correctly.

- Check the headlight and the boom light.
- Check the wiper function. (for cabin)
- Check the room lamp for lighting. (for cabin)
- Check the heater function. (for cabin)

3) Check the travel alarm function.

- To check the travel alarm function, push or pull the travel levers after the lock levers are unlocked.

## 14. Operating Instructions

### 14-1-3. Operating and checking instructions before starting up the engine

#### **! WARNING**

- Accidentally operating a control lever can cause the machine to move suddenly, possibly causing a serious accident.
- When leaving the operator's seat, be sure to place the lock levers securely in the lock position.

1) Check that the lock levers (1) are in the lock position.

#### **Note :**

When both the lock levers are in the unlock position, the engine cannot be started. Pull either lock lever up to start the engine.

2) Check that all other levers are in their appropriate positions.

3) Fasten the seatbelt snugly.

4) Insert the key into the starter switch (2) and set it to the "ON" position. Then check the following points:

[1] The buzzer will sound, and the following alarm lamps will go on.

- Engine oil pressure alarm lamp (3)
- Battery charge alarm lamp (4)
- Water temp. alarm lamp (5) (turns off in 2 to 3 seconds)

If any of the alarm lamps does not go on or the buzzer does not sound, it may mean that the alarm lamp has blown out or the wire is broken. In this event, ask the dealer for repair.

[2] Position the light switch to "ON" whether the head light and boom light will go on. If they do not go on, the lamp might have blown out or the wire might be broken. In this event, ask the dealer for repair.

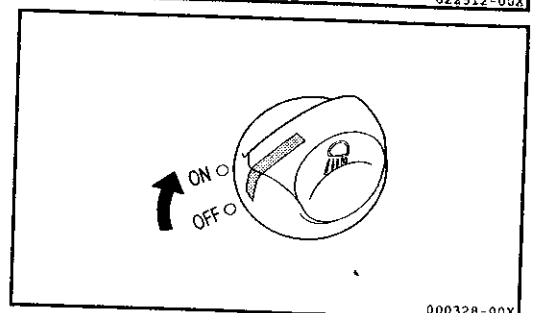
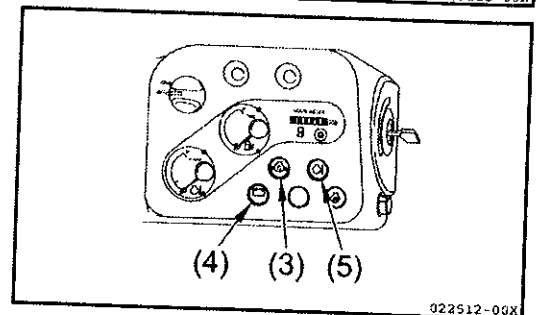
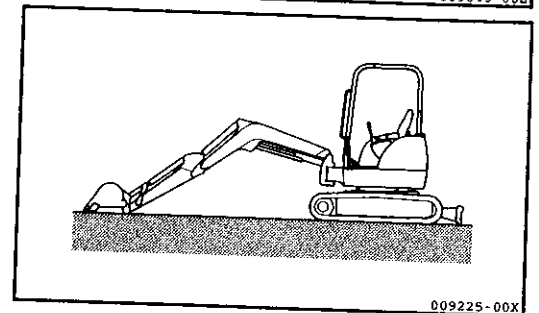
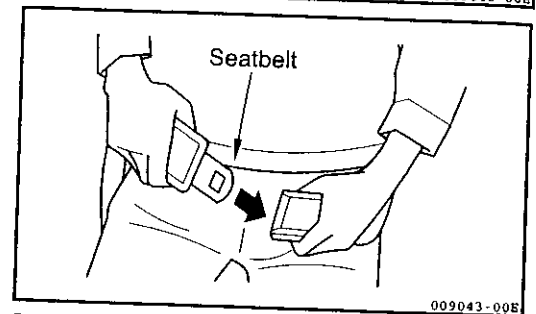
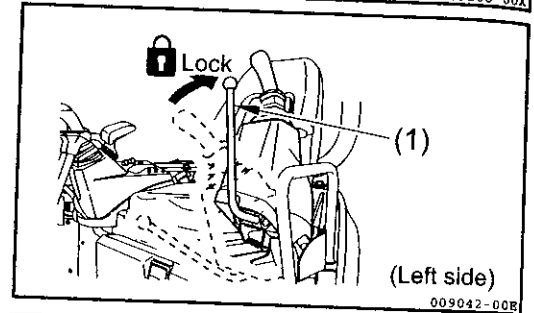
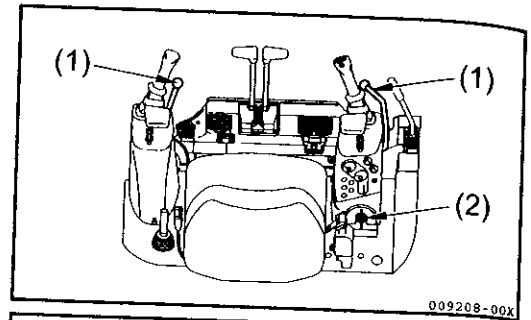

## 14-2. Starting up the engine

### 14-2-1. Normal start-up

#### **! WARNING**

- First check that there are no people or obstacles around the machine.  
Then sound the horn and start the engine.
- Be sure that you are seated in the operator's seat when starting the engine.
- When starting the engine in an enclosed place, be sure that there is adequate ventilation so that the exhaust gases can escape.

- 1) Pull the accelerator lever (1) back to the "RUN" position.
- 2) Set the key in the starter switch (2) to the "START" position. The engine will start.
- 3) After the engine has started, let go of the starter switch key.  
The starter switch key will return to the "ON" position by itself.

#### **Note :**

When the engine is warm, the engine can start up even if the accelerator lever is left in the "IDLING" position.

#### **IMPORTANT**

To protect the starter motor and the battery:

- Do not keep the key in the "START" position for more than 10 seconds.
- If the engine fails to start, do not attempt to start the engine immediately again, but set the switch to the "OFF" position and wait for approximately 30 seconds, then start the engine again.

The swing motor with a brake is used. The brake of the swing motor is released when the engine starts.

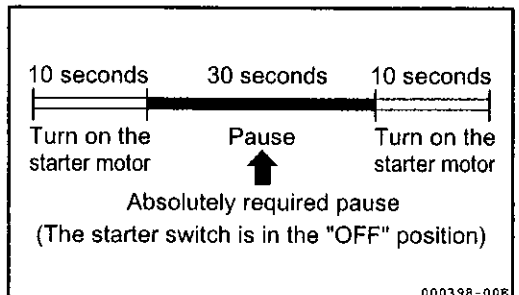
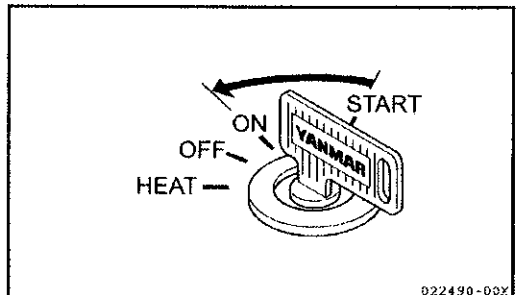
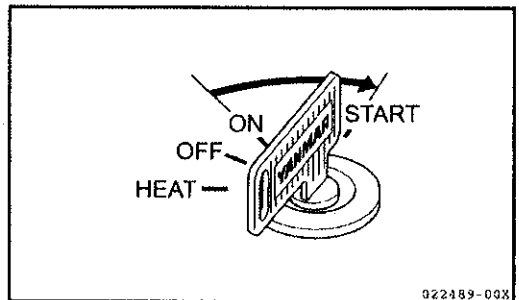
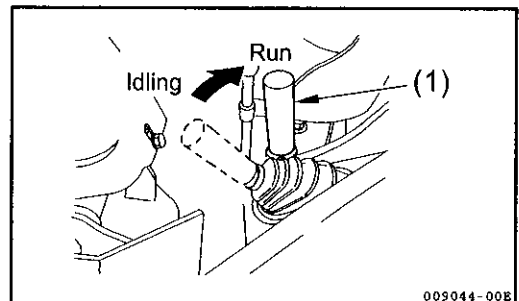
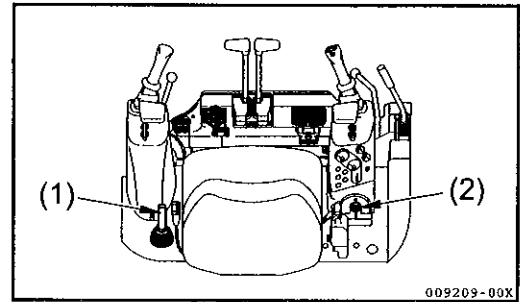

## 14. Operating Instructions

### 14-2-2. Starting the engine in cold weather

#### **⚠ WARNING**

- First check to see that there are no people or obstacles around the machine.  
Then sound the horn and start the engine.
- Be sure that you are seated in the operator's seat when starting the engine.
- When starting the engine in an enclosed place, be sure that there is adequate ventilation so that the exhaust gases can escape.

To start the engine at a low outside air temperature, follow the steps below:

- 1) Pull the accelerator lever (1) back to the "RUN" position.
- 2) Turn the key in the starter switch (2) to the "HEAT" position and keep it there for approximately 10 to 15 seconds to preheat the intake air of the engine.
- 3) Turn the key in the starter switch (2) to the "START" position to start the engine.
- 4) After the engine has started, let go of the starter switch key.  
The starter switch key will return to the "ON" position by itself.

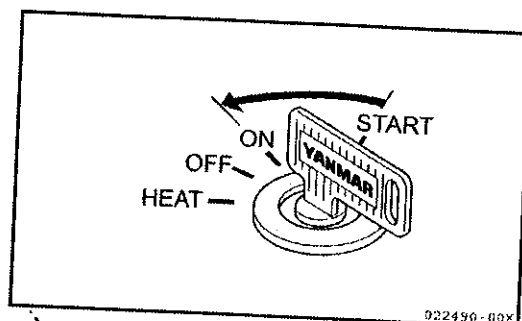
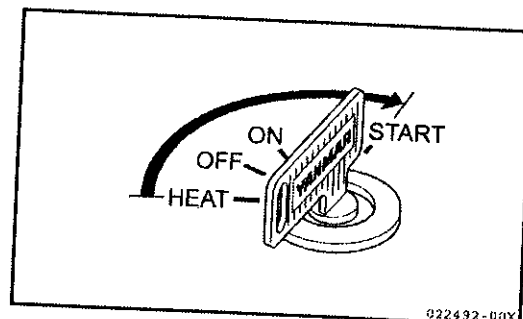
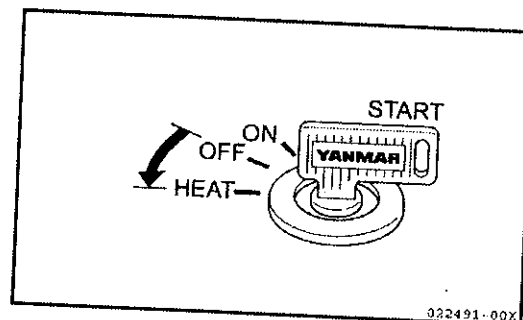
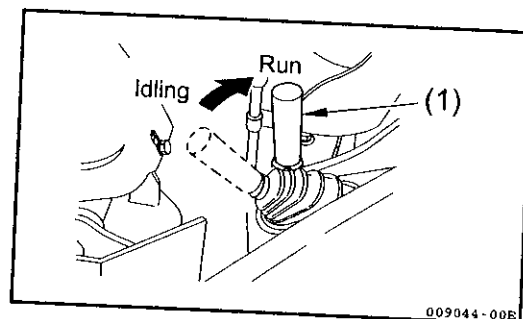
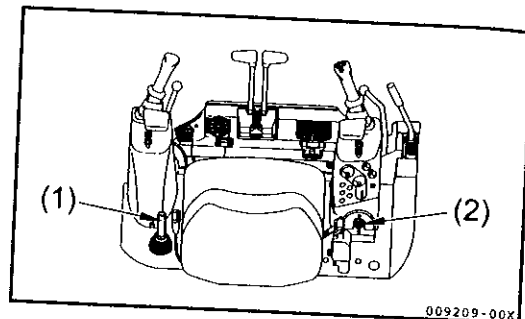



5) When the engine speed has increased, push the accelerator (1) forward to the "IDLING" position immediately.

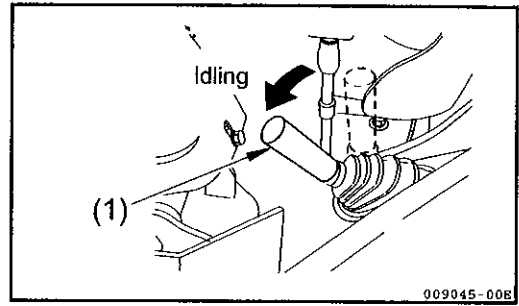

**IMPORTANT**

To protect the starter motor and the battery:

- Do not keep the key in the "START" position for more than 10 seconds.
- If the engine fails to start, do not start the engine immediately again, but set the switch to the "OFF" position and wait for approximately 30 seconds, then start the engine again.
- Traveling or operating the machine without adequate warming up in cold weather may adversely affect the machine performance, which causes low operating speed or traveling with deviation.

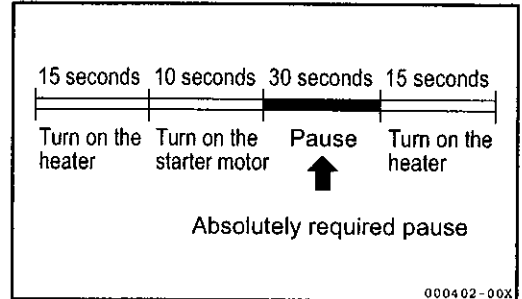

14-3. Operating and checking instructions after starting the engine

**! WARNING**

- Emergency stop.  
If abnormal operation occurs, turn the starter switch key to the "OFF" position, to stop the electrical system and the engine. Then ask your dealer to check the machine.
- Be sure to warm up the engine. If you operate the implement without full warm-up, the machine may not respond or operate properly.  
Especially in cold weather, fully warm up the engine.

**IMPORTANT**

- The proper hydraulic oil temperature is between 122°F and 176°F (50°C and 80°C).  
If you have to operate the machine at a low hydraulic oil temperature, increase the hydraulic oil temperature to about 68°F (20°C) before operating the implement.
- In the event that you have to operate any control lever at a temperature of lower than 68°F (20°C), operate it gently.
- Do not accelerate the engine rapidly until the engine warms up.

After starting the engine, do not start operating the machine immediately but follow this procedure:

- 1) Idle the engine to check that the engine oil pressure alarm lamp is off.
- 2) Pull the accelerator lever (1) to the midpoint between the "IDLING" and "RUN" positions, and run the engine with no load at medium speed for approximately five minutes.

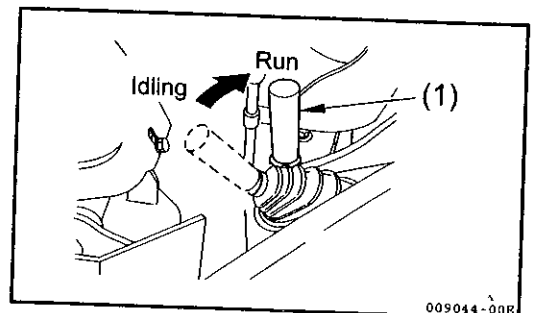
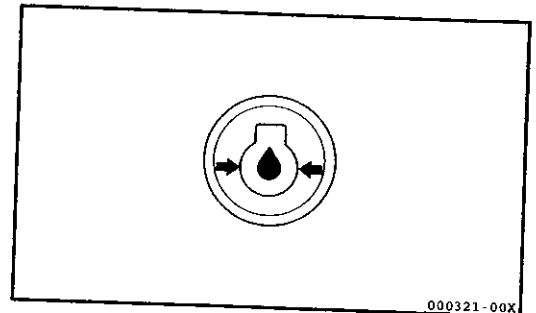
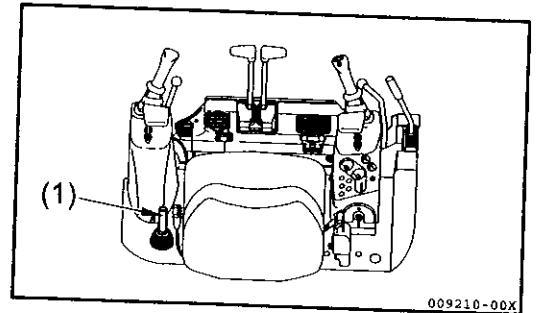

- 3) Unlock the lock levers, and lift the bucket from the ground.
- 4) Operate the bucket and arm control levers slowly to move the bucket and arm cylinders to their stroke ends. Operate the bucket for thirty seconds and the arm for thirty seconds alternately for approximately five minutes to increase the hydraulic oil temperature to 68°F (20°C).

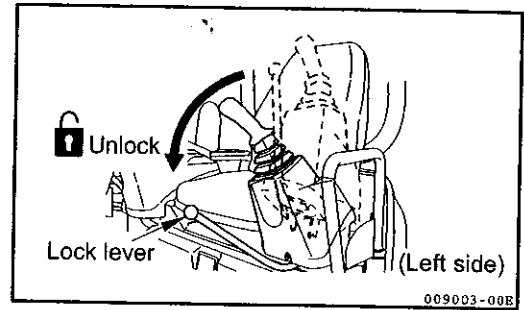

**IMPORTANT**

**When moving the implement, be careful not to bump it against the machine or the ground.**

- 5) After warming up the engine, check that the gauges and the monitor are in the following status. If there is anything abnormal, take corrective action.

- Fuel gauge (1)..... Normal
- Water temp. meter (2)..... Normal
- Hourmeter (3)..... Normal
- Engine oil pressure alarm lamp (4)..... Off
- Battery charge alarm lamp (5)..... Off
- Water temperature alarm lamp (6)..... Off

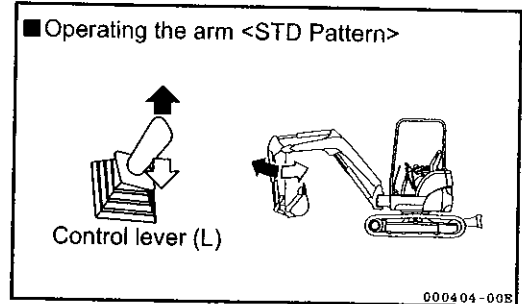

- 6) Check the exhaust gas color, the machine noise, and the vibration level for abnormality. If something is abnormal, take corrective action.

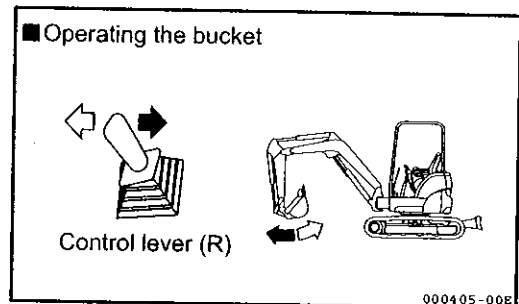

- 7) Set the lock levers to the "LOCK" position to check that the implement cannot be operated and the upperstructure cannot be swung with the left and right control levers.

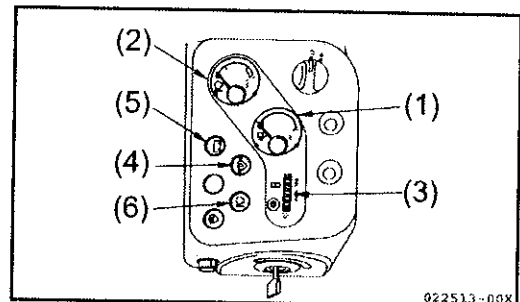

- 8) Unlock the lock levers and operate the control levers to check that the implement can be operated and the upperstructure can be swung normally with the control levers. If something is abnormal, take corrective action.

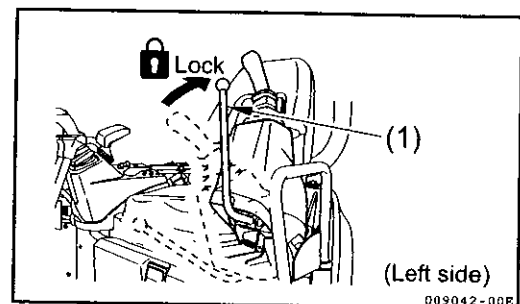

- 9) Check to see that the swing brake valve operates normally. If something is abnormal, take corrective action.

- 10) Check that no abnormal noise is heard from the hydraulic system. If any abnormal noise is heard, take corrective action.

Ask your dealer to resolve the problems described in the steps 1) to 10) above.

## 14. Operating Instructions

### 14-4. Traveling

#### 14-4-1. Traveling forward

### **⚠ WARNING**

- Always check the position of the blade before operating the travel levers and pedals. When the blade is in the rear, the travel levers and pedals operate in the reverse of the normal operation.
- A signal person should be in attendance to give signals at sites which are dangerous or not clearly in view of the operator.
- Clear all people from the working area.
- Sound the horn before beginning travel, to alert the people near the machine.
- Clear obstacles from the path of the machine.
- Do not operate the travel levers and pedals rapidly while the engine is running at high speed. Otherwise, the machine may move unexpectedly, causing a serious accident.

1) Pull the accelerator lever (1) back to the "RUN" position to increase the engine speed.

2) Unlock the lock levers (2), and retract the implement to lift it 16 to 20 in. (40 to 50 cm) above the ground.

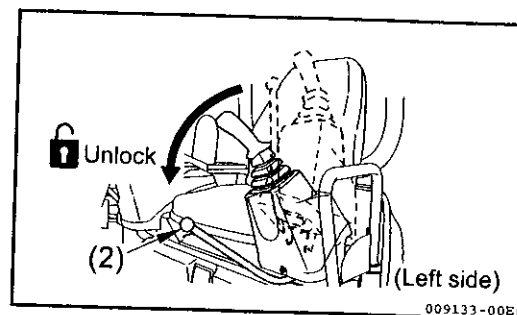
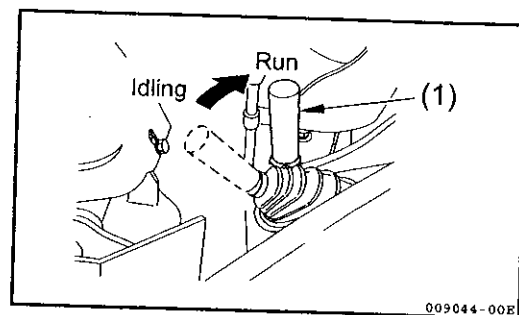
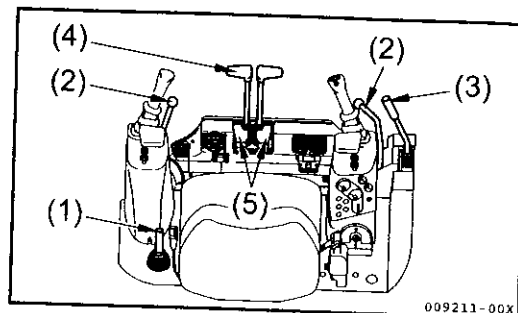

3) Pull back the blade lever (3) to lift the blade.

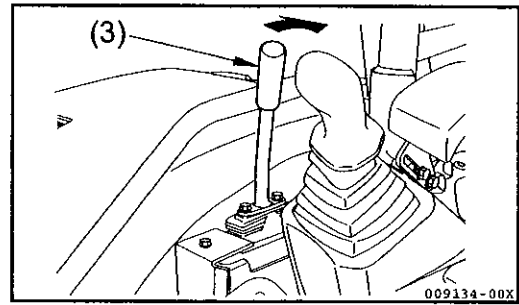

4) Operate the left and right travel levers (4) or pedals (5) as follows:

- When the blade is in the front of the machine;  
Slowly push the travel levers (4) forward or step on the front of the pedals (5) to move the machine forward.

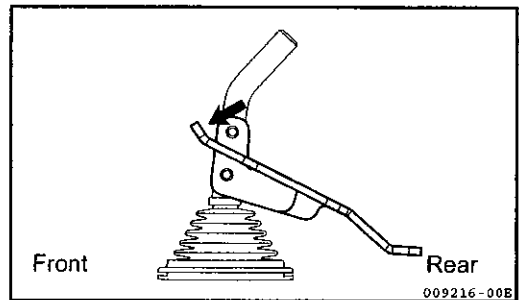
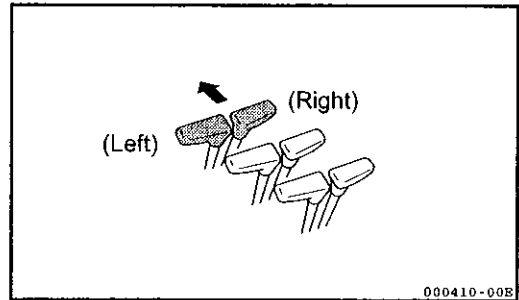

- When the blade is in the rear of the machine;  
Slowly pull the travel levers (4) back or step on the rear of the pedals in order to move the machine forward.

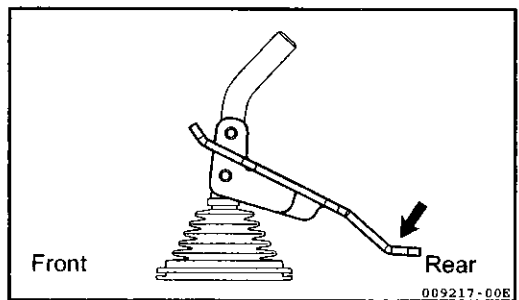
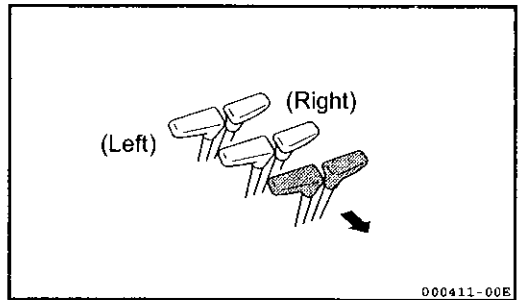

## 14. Operating Instructions

### 14-4-2. Traveling in reverse

#### **⚠ WARNING**

- Always check the position of the blade before operating the travel levers and pedals. When the blade is in the rear, the travel levers and pedals operate in the reverse of the normal operation.
- A signal person should be in attendance to give signals at sites which are dangerous or not clearly in view of the operator.
- Clear all people from the working area.
- Sound the horn before beginning travel, to alert the people near the machine.
- Clear obstacles from the path of the machine.
- There is a blind spot behind the machine. Make sure that no people are in the blind spot before traveling backwards.
- Do not operate the travel levers and pedals rapidly while the engine is running at high speed. Otherwise, the machine may move unexpectedly, causing a serious accident.

1) Pull the accelerator lever (1) back to the "RUN" position to increase the engine speed.

2) Unlock the lock levers (2), and retract the implement to lift it 16 to 20 in. (40 to 50 cm) above the ground.

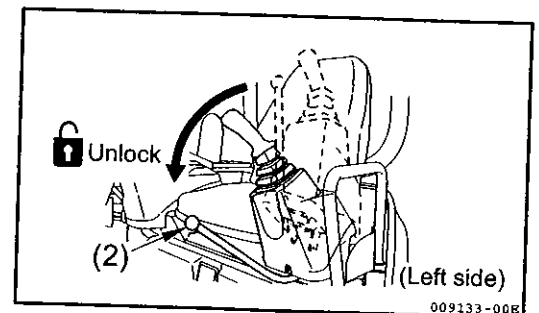
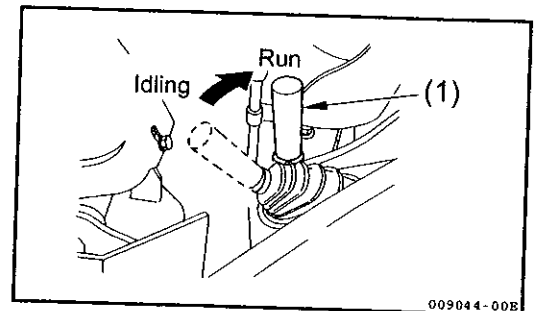
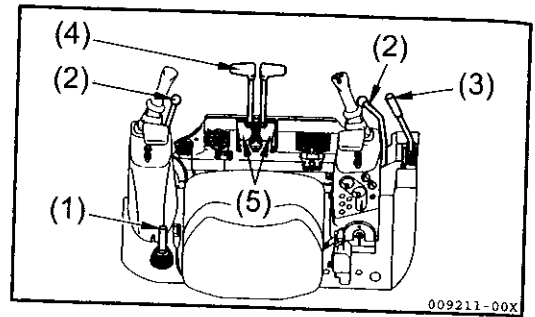

3) Pull back the blade lever (3) to lift the blade.

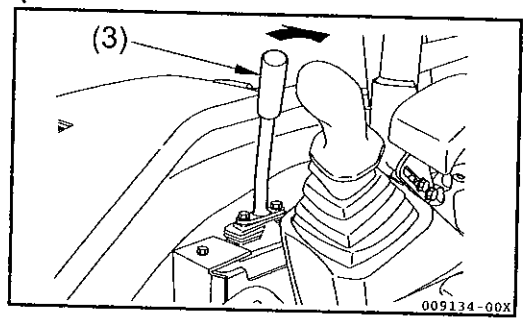

4) Operate the left and right travel levers (4) or pedals (5) as follows:

- When the blade is in the front of the machine; Slowly pull the travel levers (4) back or step on the rear of the pedals in order to move the machine backward.

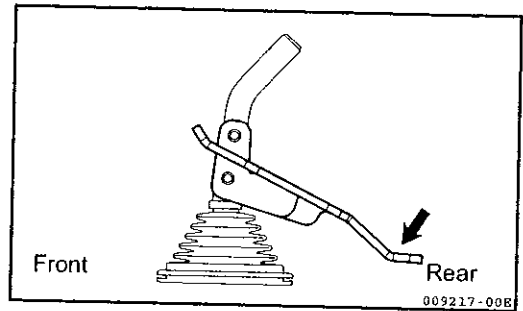
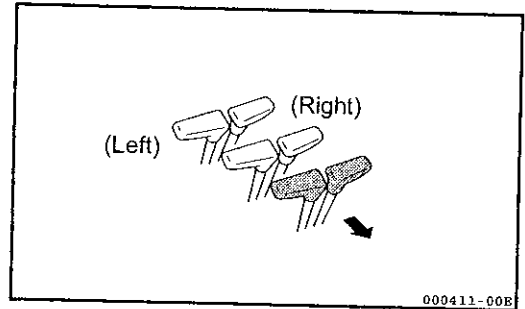

- When the blade is in the rear of the machine; Slowly push the travel levers (4) forward or step on the front of the pedals (5) to move the machine backward.

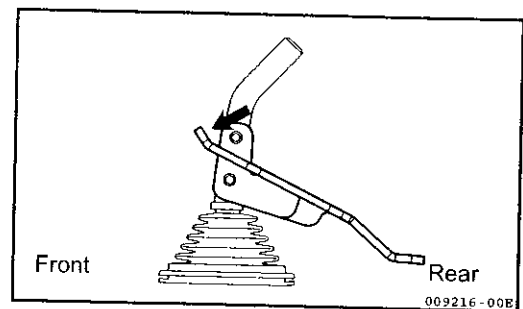
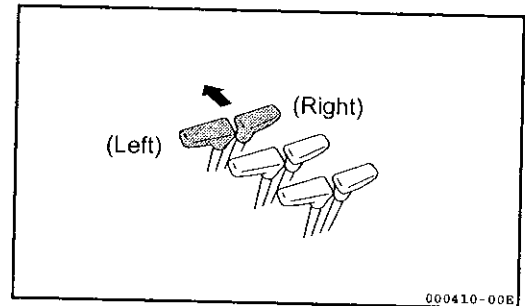

## 14. Operating Instructions

### 14-5. Steering

#### 14-5-1. Steering (Turning the machine)

### **⚠ WARNING**

Always check the position of the blade before operating the travel levers.

When the blade is in the rear, the travel levers operate in the reverse of the normal operation.

Do not use the travel pedals to steer the machine, or the machine may not be controlled expectedly, causing a serious accident.

To steer the machine, operate the travel levers only.

Do not turn the machine too sharply. Before spin-turning, stop the machine.

Operate the two travel levers (1) as follows:

#### ■ Steering the machine when it is not traveling

To turn left, push the right travel lever forward and start traveling forward on the left. Pull the right travel lever back and start traveling in reverse on the left.

#### **Note :**

To turn right, operate the left travel lever in the same manner as above.

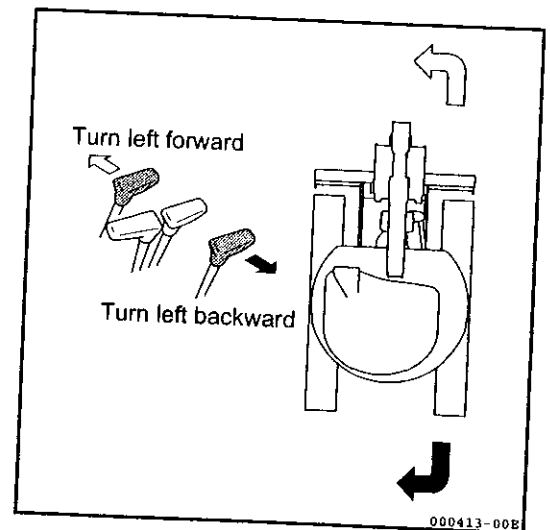
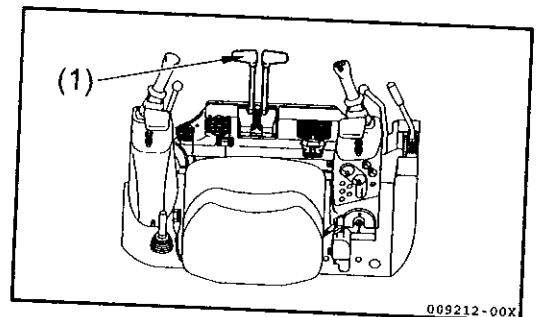



- **Steering the machine while traveling (the left and right travel levers are both tilted in the same direction)**

To turn left, return the left travel lever to the neutral position.

**Note :**

To turn right, operate the right travel lever in the same manner as above.

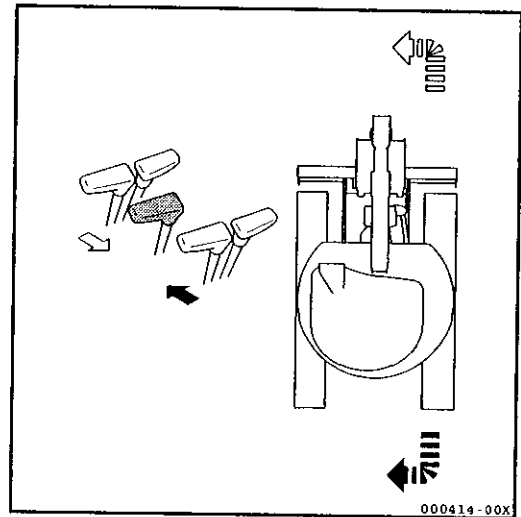

- **Spin-turning the machine when it is not traveling**

To spin-turn left, push the right travel lever forward while pulling the left travel lever back.

**Note :**

To spin-turn right, push the left travel lever forward while pulling the right travel lever back.

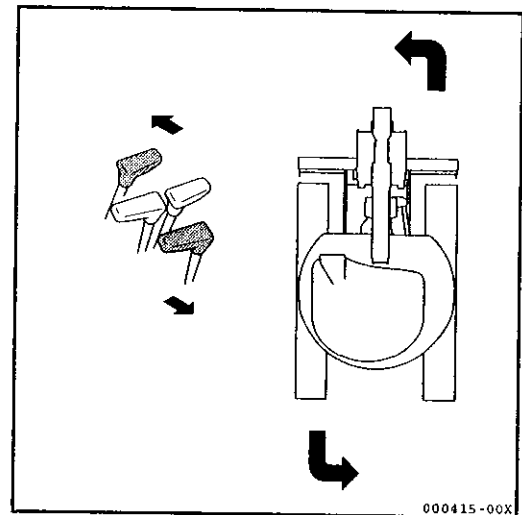

## 14. Operating Instructions

### 14-6. Stopping the machine

#### ⚠ CAUTION

Do not stop the machine suddenly but provide a safety margin.

#### ⚠ WARNING

- Park on solid, level ground.
- Do not park on a slope. If it is unavoidable to park on a slope, put solid pieces of wood under the track as blocks, place the blade on the ground, and dig the bucket into the ground.

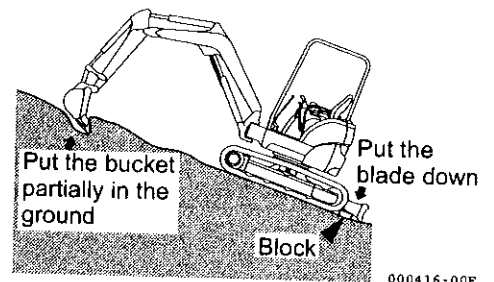

#### ⚠ WARNING

- Do not touch the control levers and pedals accidentally. Otherwise, the implement or the machine may move unexpectedly, causing serious bodily injury.
- Whenever leaving the operator's seat, be sure to place the lock levers securely in the lock position and remove the starter switch key.

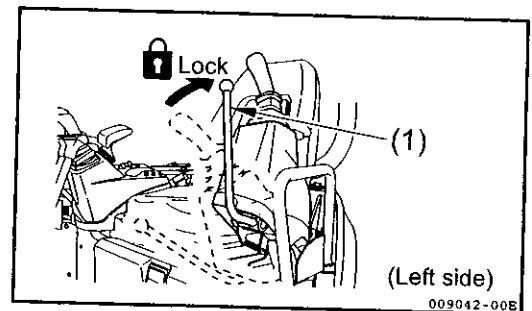

- 1) Set the right and left travel levers (1) or pedals (2) to the neutral position to stop the machine.

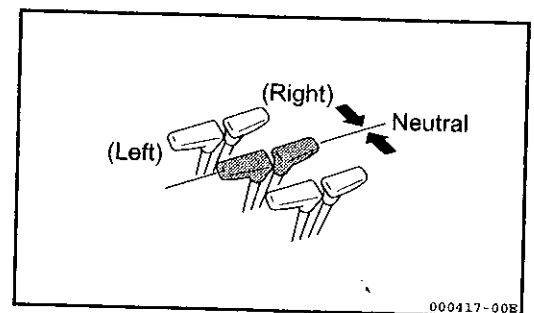
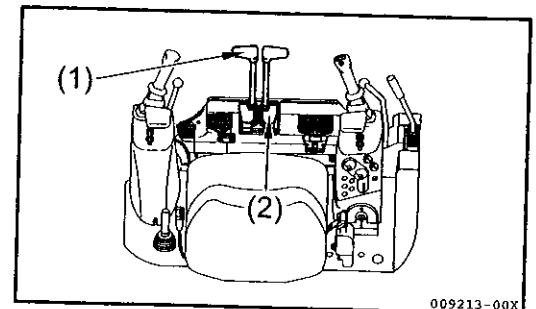

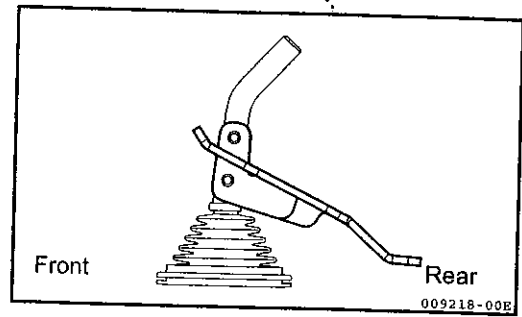

**14-7. Swinging the upperstructure**

**⚠ WARNING**  
Before swinging, make sure that there are no people or obstacles within the swing range of the implement or the machine tail.

- 1) To swing the upperstructure, operate the left control lever as illustrated in the right figure.
  - (A) : Swing right
  - (B) : Swing left

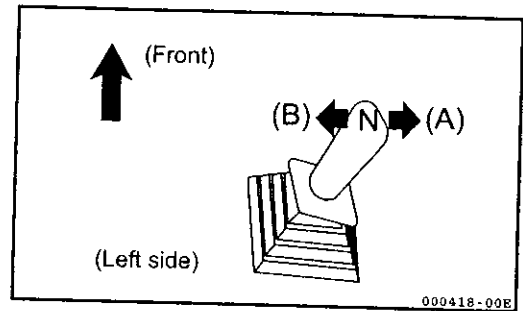

14-8. Operating the implements

**⚠ WARNING**

- Check the area around the machine for safety and sound the horn before beginning to operate the machine.
- According to the switching of pattern change lever, control lever operation can be chosen in two patterns.
- To prevent accidental injury, never operate Excavator before confirming location of pattern change lever.

Operate the machine using the right and left control levers, the boom swing pedal and the blade lever.

<STD Pattern>

- Control lever (L) : Operates arm and upperstructure swing.
- Control lever (R) : Operates boom and bucket.

<OPT Pattern>

- Control lever (L) : Operates boom and upperstructure swing.
- Control lever (R) : Operates arm and bucket.

- Boom swing pedal : Operates boom swing.
- Blade lever : Operates blade.

The relation between the operation of the levers and the boom swing pedal, and the movement of the implement are shown in the illustrations on the right. On releasing the levers and the boom swing pedal, they return to the neutral position and the implement will stop as they are.

■ Operating the arm <STD Pattern>

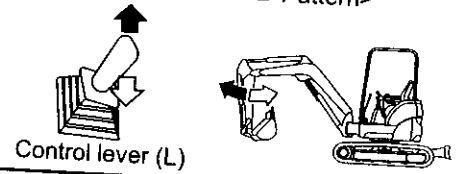

■ Operating the arm <OPT Pattern>

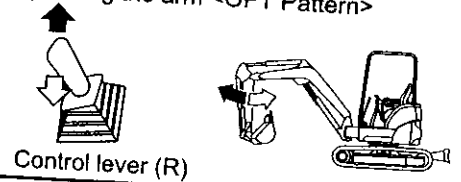

■ Swing the upperstructure

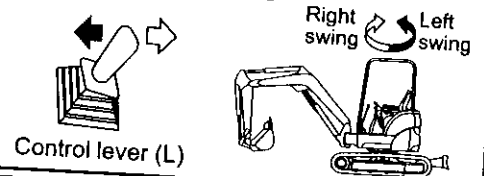

■ Operating the boom <STD Pattern>

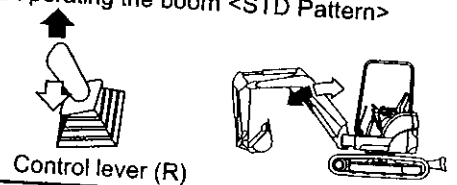

■ Operating the boom <OPT Pattern>

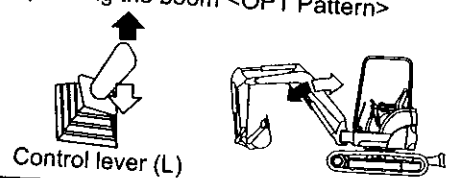

■ Operating the bucket

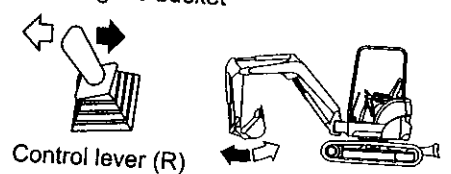

■ Operating the boom swing

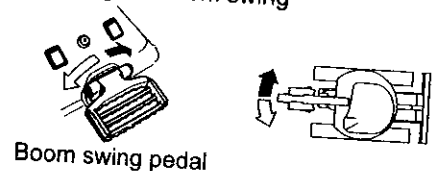

■ Operating the blade

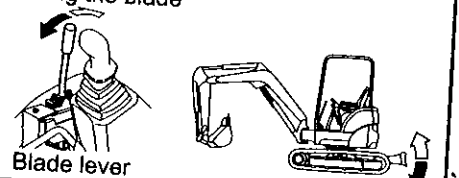

14-9. Precautions for operating the implement

**⚠ WARNING**

- Do not operate the implement control levers while traveling. Stop traveling first and then operate the implement.
- Do not operate the implement on a rocky surface (on hard and soft rocks).

■ Do not use the implement's swing force

Do not level the ground or break down a wall by the use of swing force, and do not dig the bucket teeth into the ground while swinging. Doing these may cause the implement to be damaged.

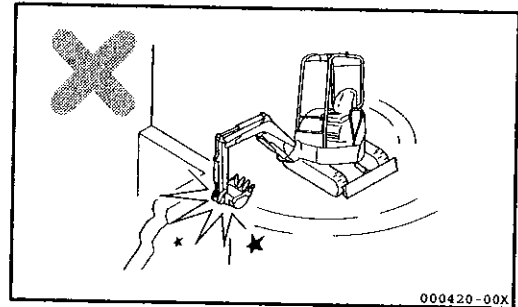

■ Do not use the implement's travel force

Do not excavate the ground by the use of travel force with the bucket teeth in contact with the ground. Doing this may cause excessive force to be imposed on the rear of the machine, shortening the machine life.

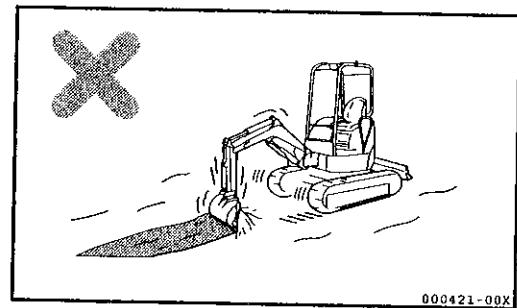

■ Take care not to operate the hydraulic cylinder to the stroke end.

Operating the hydraulic cylinder to the stroke end may impose an undue force on the stopper in the hydraulic cylinder, shortening the implement life. Operate with a small safety margin.

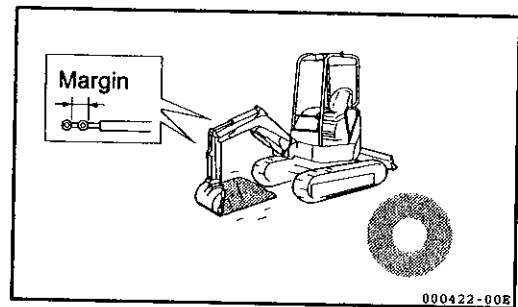

■ Do not operate the implement by the using the dropping force of the bucket

Do not excavate the ground by using the dropping force of the bucket as a pickaxe or pile driver. Doing this may cause excessive force to be imposed on the rear of the machine, shortening the machine life and possibly causing a serious accident.

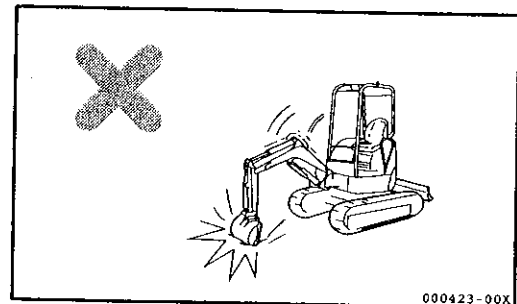

## 14. Operating Instructions

- **Do not operate the implement by using the dropping force of the machine**

Do not excavate the ground by using the dropping force of the machine.

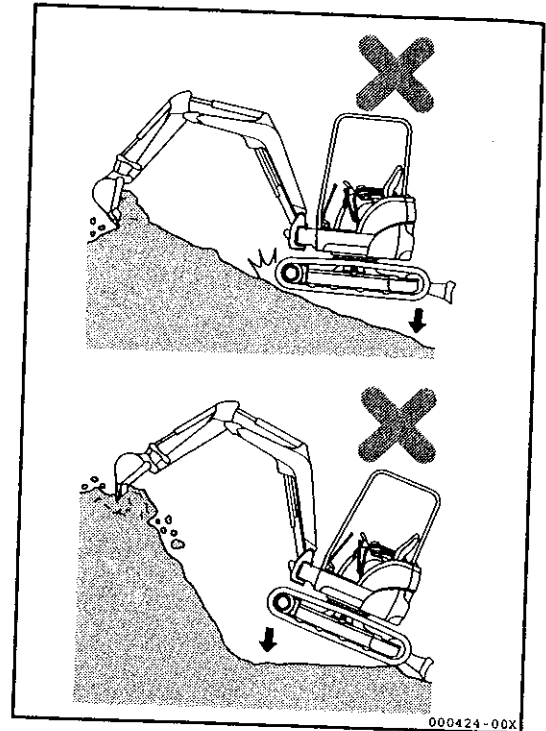

- **Excavating a hard rock**

It is recommended that a hard rock first be broken into small pieces by other means. Doing so will prevent damage to the machine and will increase economy.

- **Do not suspend a load unless you use a hooked bucket**

Suspending a load safely requires the use of a hooked bucket. Refer to Section "32. Handling the Hooked Bucket".

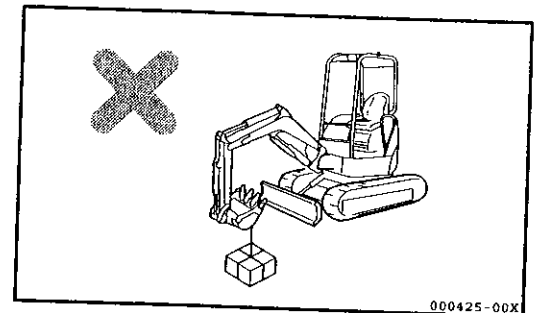

■ **Do not bump the blade against a large rock or boulder**

Do not bump the blade against a large rock or boulder. Doing so may cause the blade or the hydraulic cylinder to be damaged.

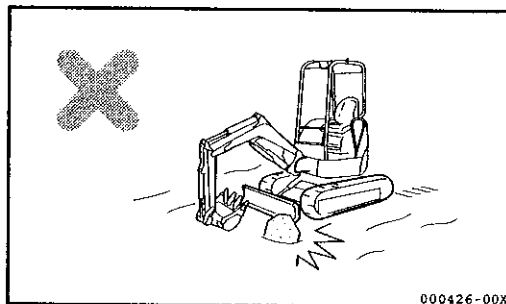

000426-00X

■ **Be careful when retracting the implement**

When retracting the implement for travel or transport, be careful that the bucket and the blade never bump against each other.

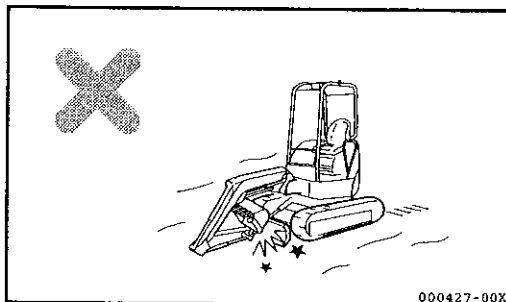

000427-00X

■ **Support the blade on both sides**

When you use the blade as an outrigger, support the blade on both sides.

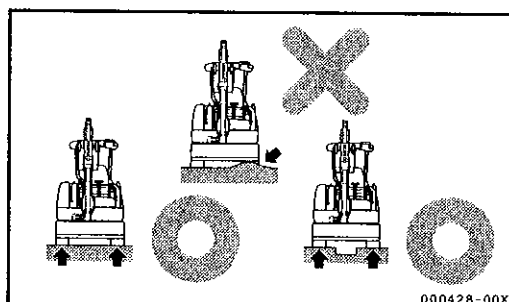

000428-00X

■ **Be careful not to bump the blade when excavating**

When excavating the ground with the blade in front, never let the blade bump against the boom cylinder. Place the blade in rear, if it is not being used.

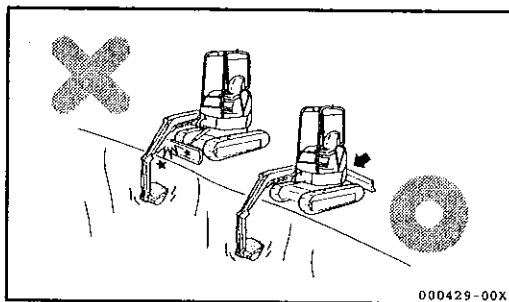

000429-00X

## 14. Operating Instructions

### 14-10. Precautions for working

#### ■ Precautions for traveling

Driving over a stone or a stump subjects the machine (especially undercarriage) to a shock, which may cause damage to the machine.

Avoid such obstacles by driving around them, or removing them.

If driving over them is unavoidable, reduce speed, hold the implement close to the ground, and drive over the obstacles with the center of the track shoes.

#### ■ Allowable water depth

##### IMPORTANT

When driving out of water, if the machine climbs a slope at an angle of more than 15 degrees, the rear of the upperstructure may submerge too deeply in the water, which may damage the radiator fan since the radiator fan paddles the water. Avoid this if possible when driving out of water.

The limit of the water depth in which the machine can be used in is up to the center of the carrier roller.

Apply a generous amount of grease to the moving parts (especially bucket pin) that have been submerged in the water for a long time until the used grease is extruded out of the bearings.

Wipe the extruded used grease off with a waste cloth.

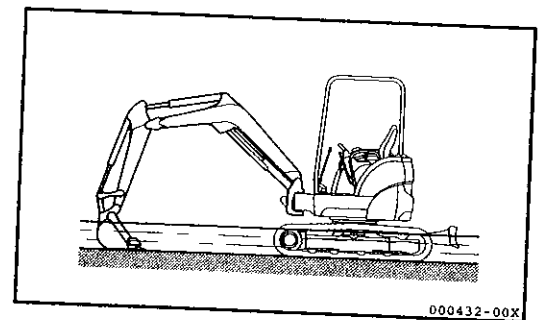
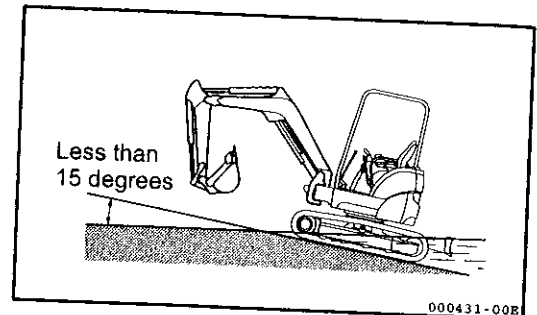
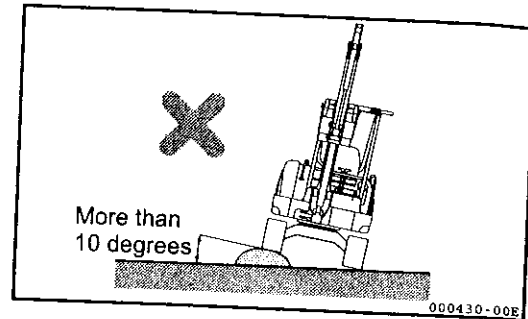



## 14-11. Precautions for going up and down a slope

**⚠ WARNING**

- When traveling on a slope, place the implement in the direction of travel and raise the bucket 8 to 12 in. (20 to 30 cm) above the ground.
- When driving over obstacles such as foot paths, hold the implement close to the ground and drive the machine slowly.
- Never turn on or traverse a slope. Descend to flat ground to make a course change.
- If the machine is starting to slip or you feel that the machine is unstable, place the bucket on the ground and stop the machine at once.
- Recognize that the machine may roll over when swinging the upperstructure or operating the implement on a slope. Do not swing the upperstructure toward the downward side of the slope with a load in the bucket. If swinging is unavoidable, first lay earth on the slope to maintain the machine as horizontal as possible, then swing the upperstructure.
- Do not travel on a slope of 20 degrees or more, as the machine may upset.

- 1) Go down slopes at low speed, using the travel levers and accelerator lever to control your speed. When going down a slope, drive the machine at low engine speed and position the implement as shown in the right figure.

- 2) When climbing a slope, drive the machine with the implement positioned as shown in the right figure.

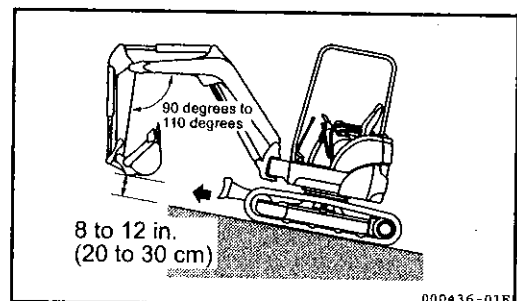
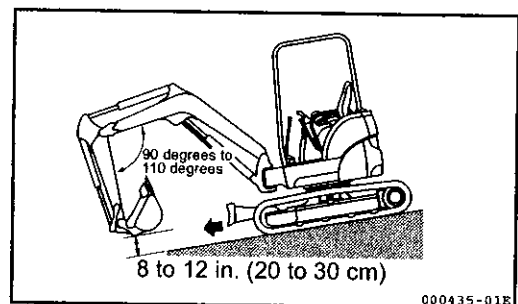
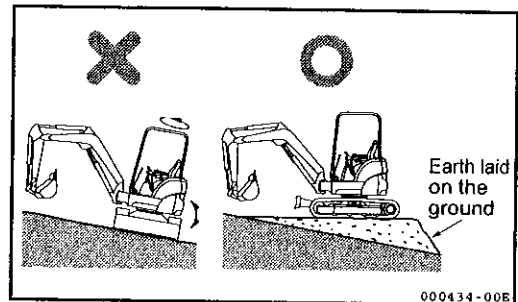
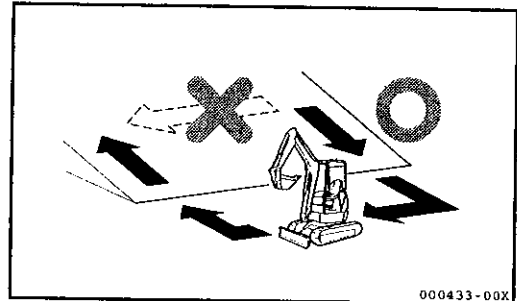

## ***14. Operating Instructions***

---

### **■ Braking when going down a slope**

When going down a slope, you can automatically brake the machine by setting the travel levers to the neutral position.

### **■ When the tracks are slipping**

If you cannot climb a slope by operating the travel levers because the tracks are slipping, retract the arm and make use of the pull-back power of the implement to climb the slope.

### **■ When the engine stops**

If the engine stops while climbing a slope, set the travel levers to the neutral position, stop the machine, and restart the engine.

### **■ Precautions for traveling on a slope.**

Do not open or close the cabin side door on a slope. Doing this may cause the door to swing open or closed very rapidly.

Be sure to lock the cabin side door in either the open or closed position.

## 14-12. Escaping from the mud

Carefully operate the machine not to allow it to get mired in mud. If the machine is mired in mud, the machine can escape as follows:

### 14-12-1. If only one track is mired in the mud

If only one track is mired in the mud, place the bucket on the muddy side, lift the track above the ground, lay a log or a wood block under the track shoe, and raise the bucket to escape.

#### IMPORTANT

When lifting the machine above the ground with the boom or the arm, press on the ground with the bottom of the bucket. (Do not press on the ground with the bucket teeth.)

In doing this, the angle between the boom and the arm should be 90 degrees to 110 degrees.

The same manner as above should be applied when the bucket is in the reverse position.

### 14-12-2. If both tracks are mired in the mud

If both tracks are mired in the mud, lay a log or a wood block under the track shoes in the same manner as mentioned above, dig the bucket into the solid ground, retract the arm just as when excavating, and set the travel lever to the "FORWARD" position to escape from the mud.

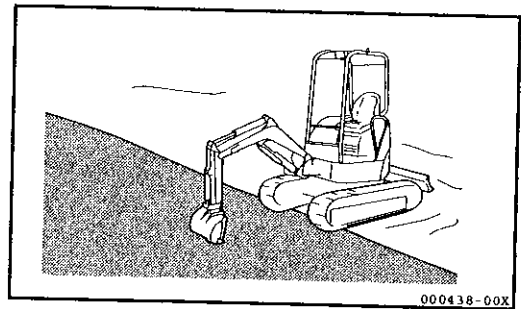
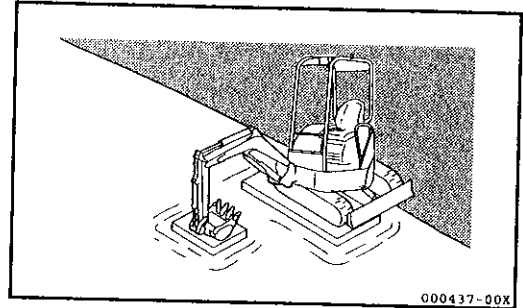

## 14. Operating Instructions

### 14-13. Operations using the bucket

You can greatly widen the range of work described here by using optional attachments.

#### 14-13-1. Backhoe operation

Backhoe operation is suitable for digging the ground below the machine.

Suppose that the machine is operating as illustrated in the right figure : a maximum digging force of each cylinder can be obtained when the angle between the bucket cylinder and the bucket arm as well as between the arm cylinder and the arm is maintained at 90 degrees.

When digging, make good use of this angle to increase the operating efficiency.

To excavate the ground efficiently by manipulating the arm, the arm needs to be operated within a range of angles between 45 degrees forward and 30 degrees backwards, as illustrated in the right figure. Though the range differs according to the depth of the work, do not move the implement to the cylinder stroke end.

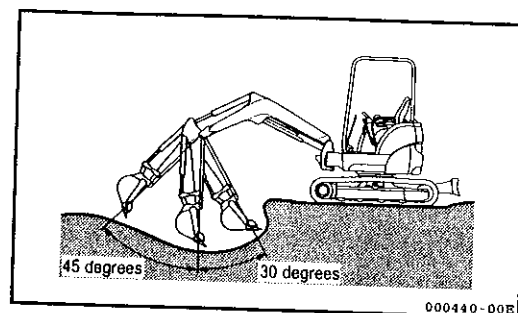
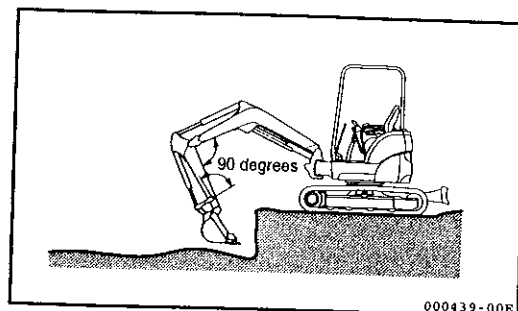

#### 14-13-2. Ditching

To increase work efficiency, install a suitable bucket for ditching and position the tracks in parallel with the ditch to be made.

To make a wide ditch, first dig the two sides, and then dig the center.

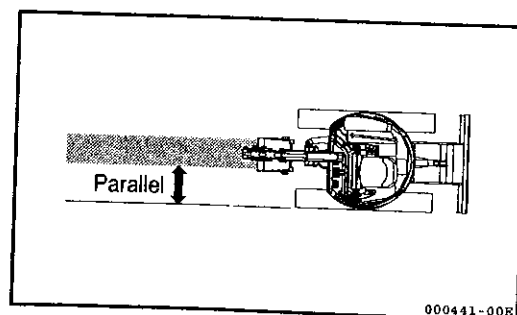

#### 14-13-3. Loading

To increase work efficiency, locate the dump truck at a position where the swing angle of the machine will be minimized and the operator can clearly view the dump truck.

Load earth from the rear of the dump truck, because it can be loaded more easily and in larger amount than from the side.

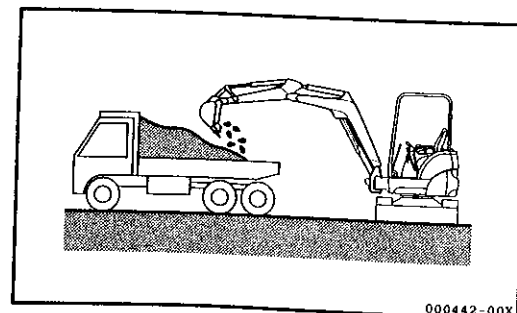

**14-14. Handling quick coupler**

**14-14-1. Features of quick coupler**

The quick coupler is the device to simplify the replacement of a variety of attachments for hydraulic implement. The distance between pins is adjustable so that the attachments with different distances between pins are available.

**14-14-2. Description of switches**

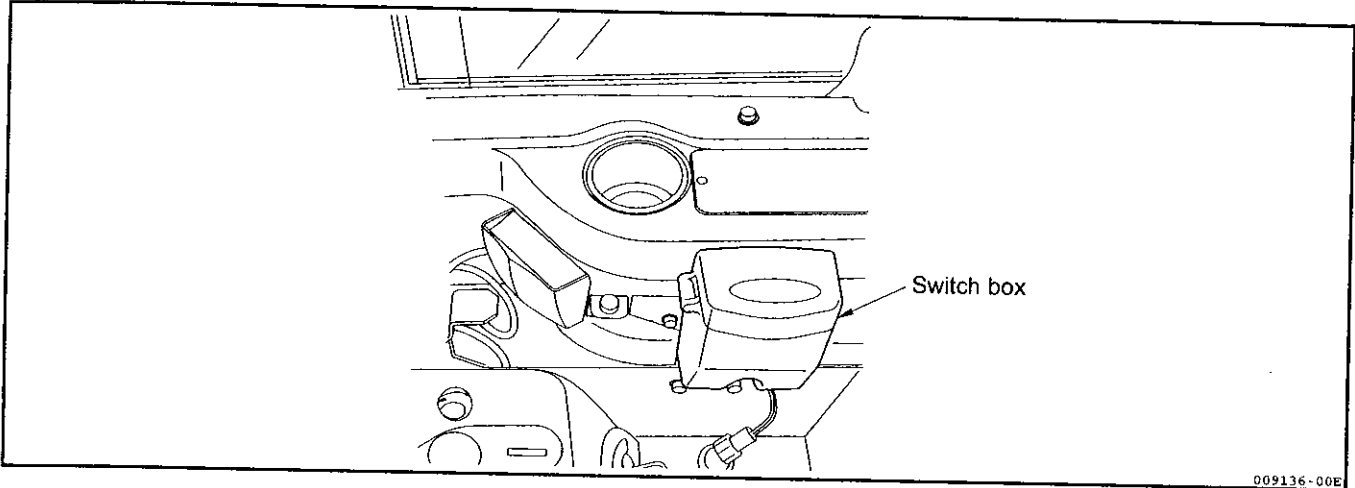

009136-00E

**⚠ WARNING**

Never open the Switch Box cover except when mounting or dismounting the Attachment to prevent accidental activation of the Quick Coupler. This may cause breakdown or sudden operation of the Attachment, causing serious accident.

1) Control switch of quick coupler  
Use this switch to dismount or mount the attachment.

Operating control switch to dismount or mount the attachment	
Dismounting of attachment	Mounting of attachment
<p>(1) Press</p> <p>Power supply switch goes on, and beeps sound.</p>	<p>(1) Turn to the right</p>
<p>(2) Turn to the left</p> <p>Lamp goes on.</p>	<p>(2) Press</p>

000483-00E

000484-00E

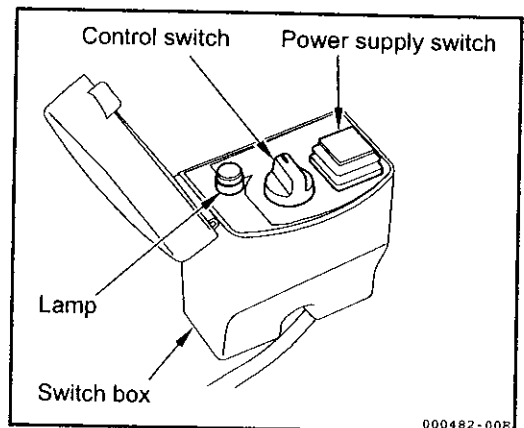

000482-00E

14. Operating Instructions

14-14-3. Structure of quick coupler

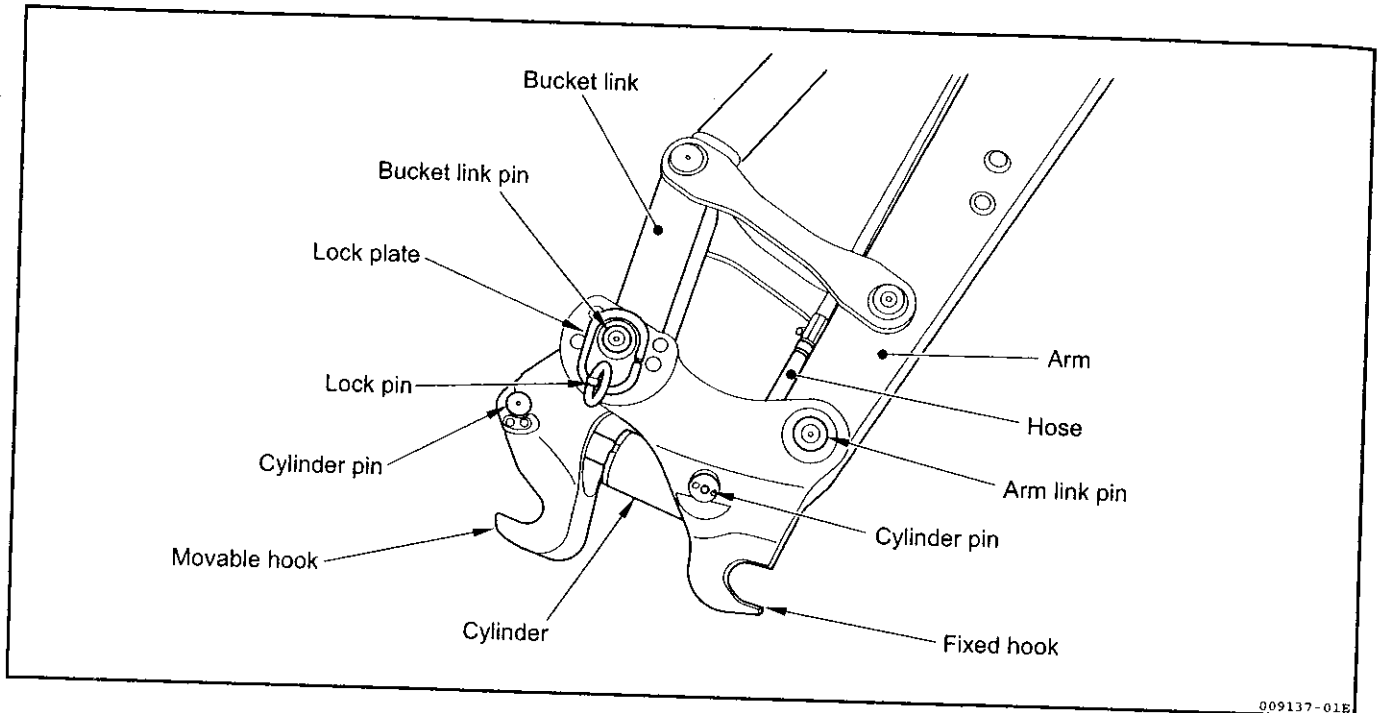

009137-01E

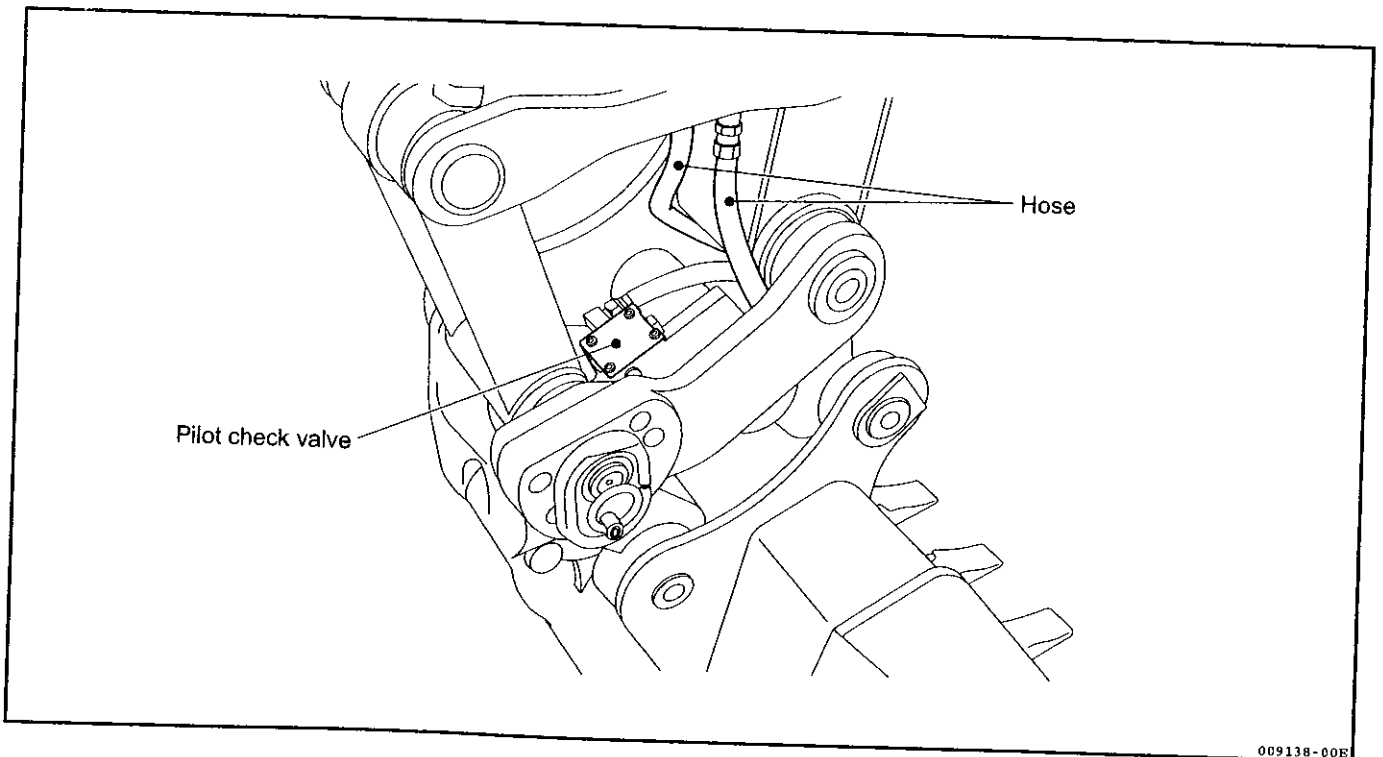

009138-00E

**14-14-4. Attachment types**

- 1) The attachments, which can be mounted on the machine with quick coupler, are only the same 2-pin type as the bucket. The 1-pin type such as clamshell cannot be mounted in the quick coupler.
- 2) The following 2-pin type of attachments exceptionally cannot be mounted in the quick coupler.
  - (1) Attachments much different from the standard bucket in shape of mounting part
  - (2) Attachments with excessively long or short pin pitch
- 3) Do not use any attachments improper for the machine with the quick coupler.

**14-14-5. Allowable size of bucket**

Allowable size of bucket to be mounted in the quick coupler

Unit : in. (mm)

Mark	Part	VI045-5B / VI055-5B	
A	Attachment width	5.51 (140) or more	
B	Distance between pins	Pin diameter Ø1.57 (40)	7.52 to 11.7 (191 to 298)
		Pin diameter Ø1.77 (45)	7.95 to 12.5 (202 to 317)
C	Operating radius of bucket	34.6 (880) or less	
D	Pin diameter	Ø1.57 to 1.77 (40 to 45)	

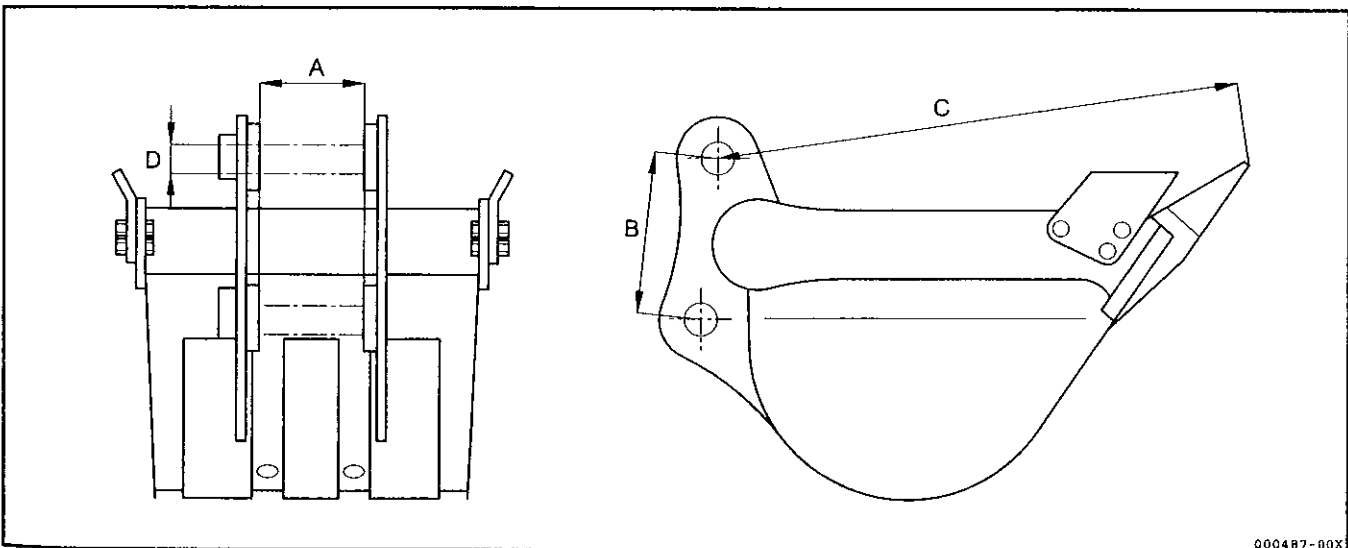

## ***14. Operating Instructions***

### **14-14-6. Phenomena that are not breakdowns**

While setting the control switch of the quick coupler in the dismantling mode, stop the engine and then restart it to open the hook of the quick coupler.

### **14-14-7. Posture for storing the machine without attachment**

Place the quick coupler on the ground as illustrated in the right figure for a long-term storage.

If the quick coupler is placed on the ground when the control switch is in the dismantling mode, the hook will open when the engine is restarted, causing the floor surface scratches or the machine breakdown.

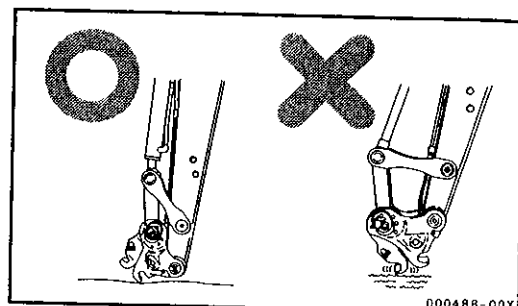



## 14-14-8. Dismounting attachment

**⚠ WARNING**

- Never dismount the Attachment while it is still elevated, as it will drop to the ground and could cause bodily injury.
- Never dismount the Attachment unless it is resting on stable level ground, as it could otherwise fall over.

1) Park the machine on stable level ground.

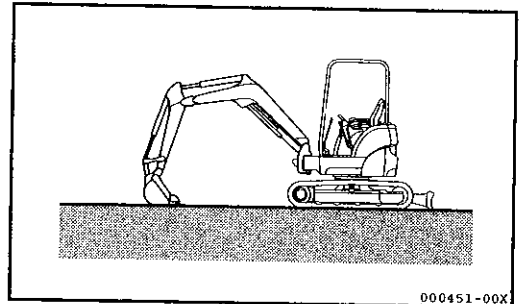

2) Lower the attachment onto the ground.

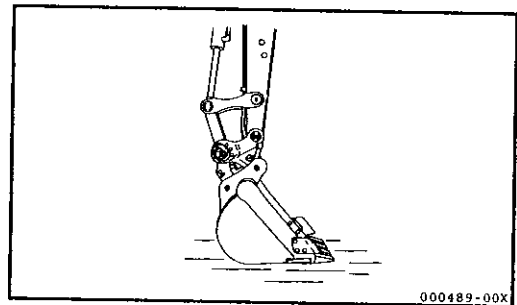

3) Set up the handle of the lock pin.

4) Turn the arrow on the head of the lock pin from the lock position to the unlock position, and then pull it up.

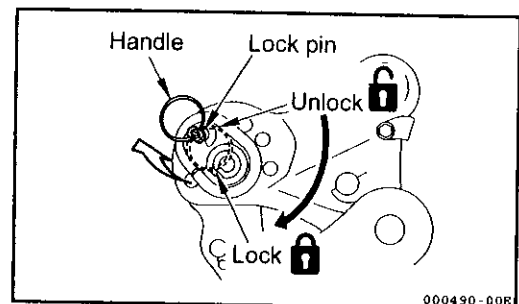
**IMPORTANT**

The lock pin cannot be removed from the body.

## 14. Operating Instructions

5) Open the switch box cover.

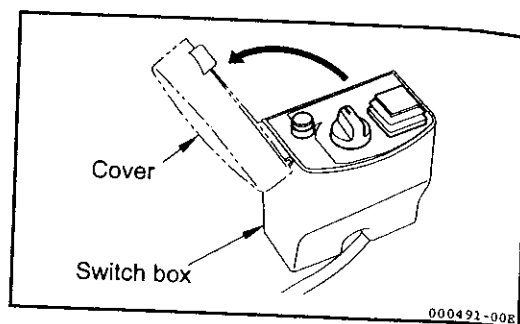

6) Press the power supply switch.  
Then, beeps sound and the power supply switch blinks.

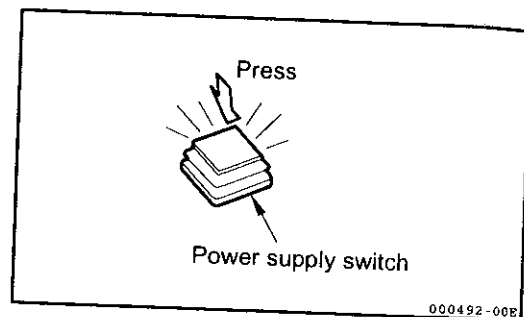

7) Turn the control switch to the dismounting position on the left side, and the attachment is dismounted.

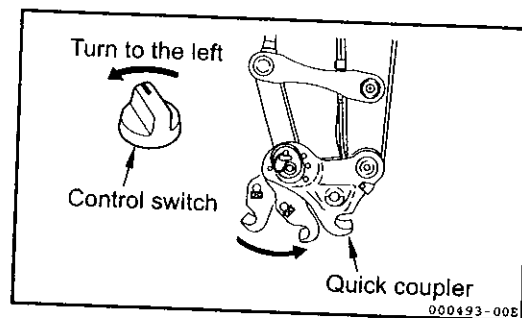

8) Remove the quick coupler from the attachment.

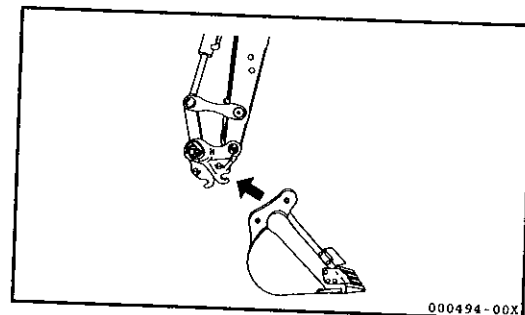

## 14-14-9. Mounting attachment

**⚠ WARNING**

- Never place your hands or any other part of your body between the Quick Coupler and the Attachment to prevent bodily injury.
- Never stand near the Attachment unless it is resting on stable level ground to avoid bodily injury.
- Never use a newly mounted Attachment before confirming that it has been properly secured to the Quick Coupler, and that the Lock Pin has been correctly installed, as accidental detachment could otherwise result.
- Always replace the Lock Pin if damaged or lost. Failure to do so could result in death or serious injury.

- 1) Place the attachment on stable level ground.  
Be sure to install the pins into the attachment.

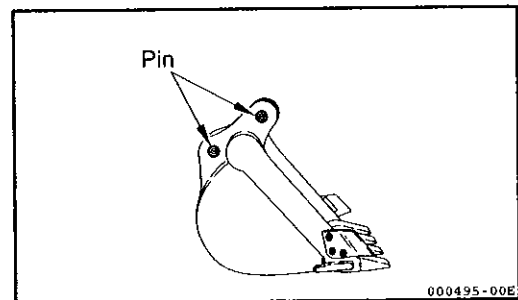

- 2) Close the movable hook.
- 3) Put the fixed hook onto the pin of the attachment on the arm side and set the quick hitch level with the ground as illustrated in the right figure.

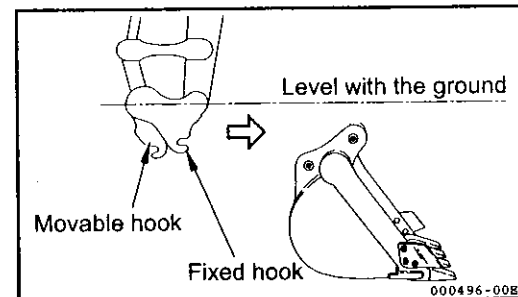

- 4) Lift the attachment up in that state.

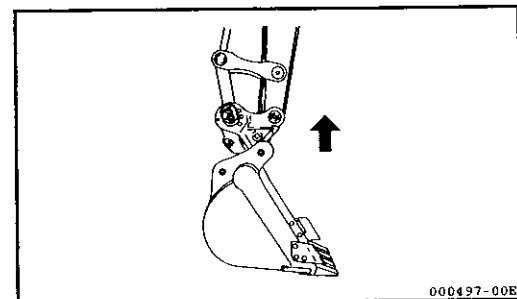

## 14. Operating Instructions

- 5) Curl the attachment so that it is level.
- 6) Turn the control switch to the mounting position on the right side, and the attachment is mounted.
- 7) Only one of the bores allows the whole lock pin. Install the lock pin to that bore.
- 8) Turn the arrow on the lock pin to the lock side.
- 9) Put the handle of the lock pin down to the arrowed side.
- 10) Make sure the attachment is securely mounted in the quick coupler before pressing the power supply switch on. The beeps stop sounding and the red lamp goes off.
- 11) Close the switch box cover.

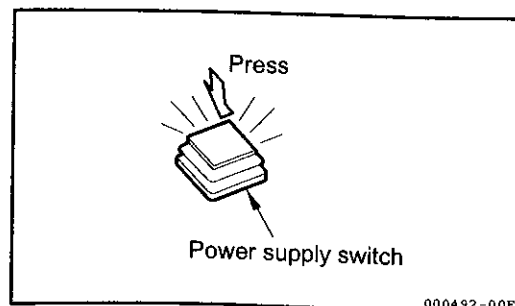
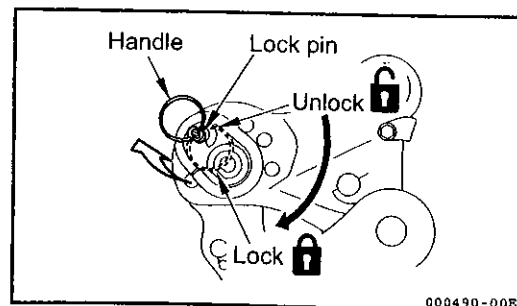
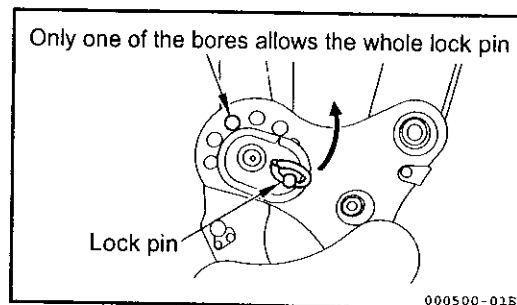
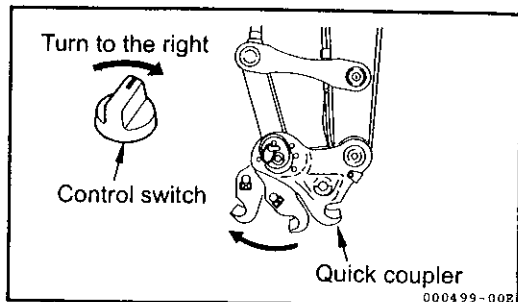
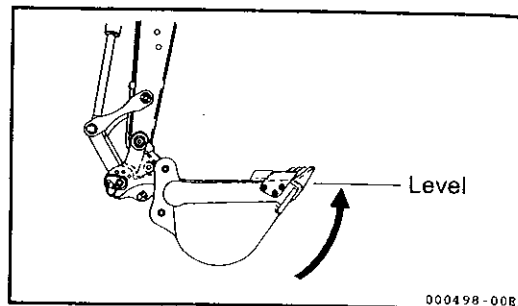

**14-14-10. Maintenance**

1) Checking specifications

- Check there are no cracks and plays.
- Check the bolts and nuts for looseness.
- Check the hydraulic piping for oil leak.

2) Installation instruction of the Lock Pin

- (1) Remove the damaged lock pin if any, and clean the bore of the lock plate.

**Note:**

*Replace the lock plate with a new one if it is damaged.*

- (2) Put a new lock pin into the bore of the lock plate.

- (3) Install the washer and nut onto the lock pin from the back side of the lock plate.

**Note:**

*Apply a lock agent ThreeBond 1324 on the thread.*

- (4) Tighten the nut (M6, Hex 10 mm) to 7.5 to 8.5 ft•lb.

- (5) Confirm if the new lock pin can smoothly move to the lock and unlock positions.

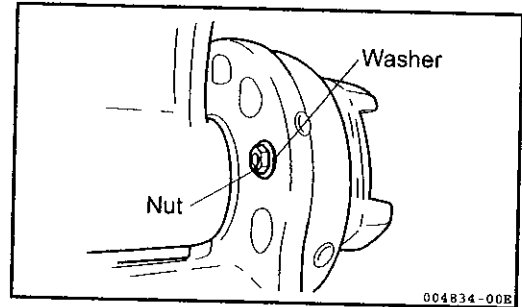
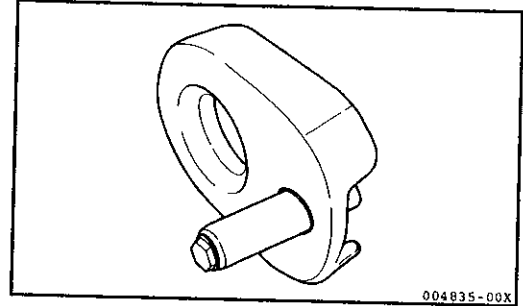

3) Greasing

**IMPORTANT**

**Grease the fittings thoroughly after washing the machine or after operation in rain, on soft ground, or in muddy water.**

- (1) Put the bucket and the blade on the ground and stop the engine.
- (2) Clean the grease nipples indicated with the arrows in the right figures and grease them using a grease gun.
- (3) After greasing, wipe off the excessive grease with waste cloth or the like.

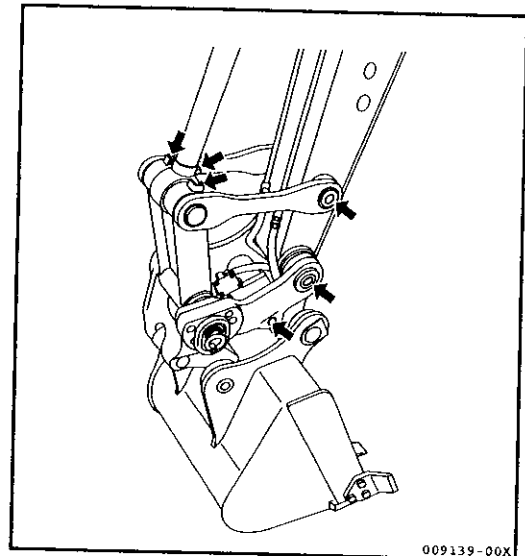

#### *14. Operating Instructions*

##### 4) Nonperiodic inspection

- The pins in the attachment are free from rotation and cannot be worn.  
Apply antirust solvent or grease to them to prevent rust.

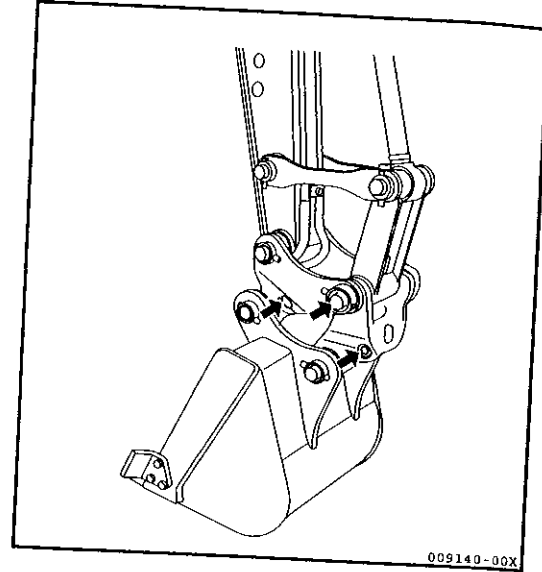

14-15. Parking the machine

**! CAUTION**

Do not stop the machine suddenly, but try to stop with a safety margin.

**! WARNING**

- Park on solid, level ground.
- Do not park on a slope. If parking on a slope is unavoidable, block the tracks with solid pieces of wood, place the blade on the ground, and dig the bucket into the ground.

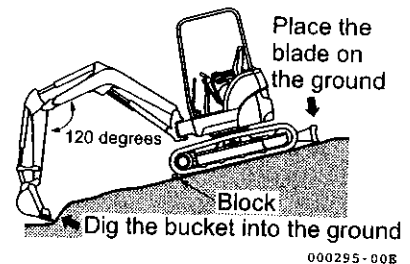

**! WARNING**

- Do not touch the control levers and pedals accidentally. Otherwise, the implement or the machine may move unexpectedly, causing a serious accident.
- When leaving the operator's seat, be sure to place the lock levers securely in the lock position and remove the starter switch key.

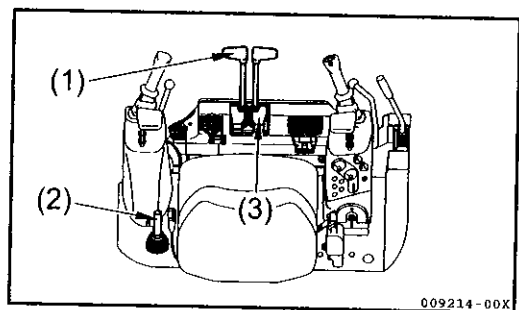

1) Set the left and right travel levers (1) or pedals (3) to the neutral position to stop the machine.

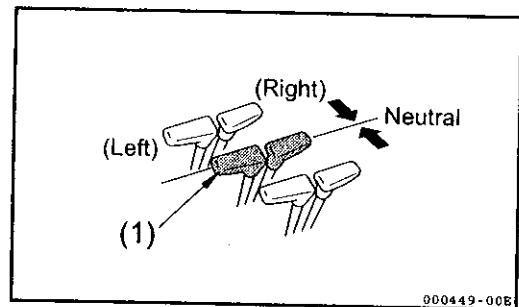

2) Idle the engine with the accelerator lever (2).

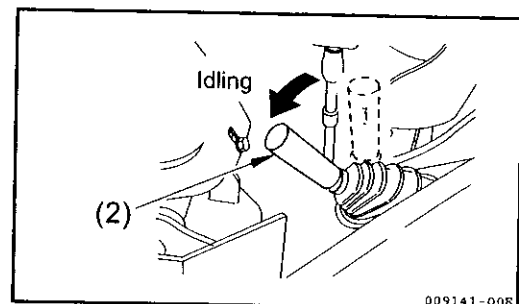

## 14. Operating Instructions

- 3) Place the bucket on the ground with its bottom surface in contact with the ground.
- 4) Place the blade on the ground.
- 5) Set the lock levers to the "LOCK" position.

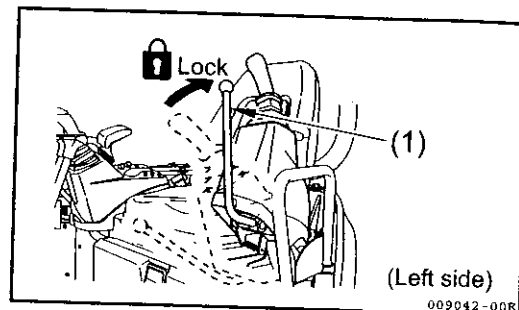
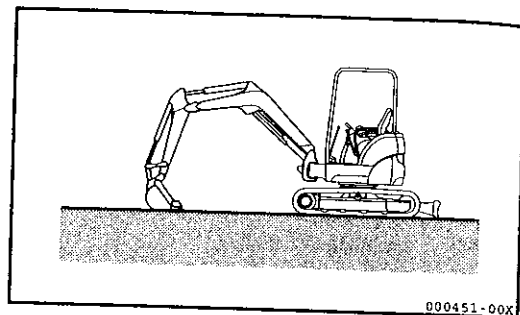

## 14-16. Inspection requirements after completing operation

Check the water temp. meter (1) and the engine oil pressure alarm lamp (2), and also check the residual quantity of fuel with the fuel level gauge (3).

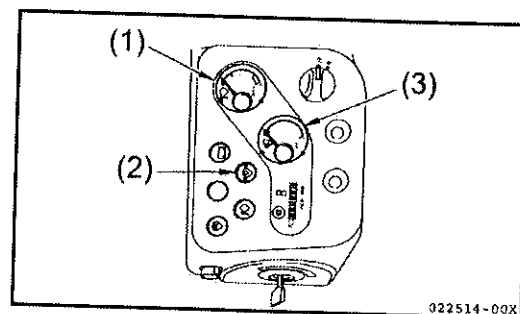



## 14-17. Stopping the engine

### IMPORTANT

- Stopping the engine after rotation at high speed may shorten the engine life. Do not stop the engine suddenly except in case of emergency.
- If the engine is overheated, do not stop the engine immediately. Gradually lower the engine temperature by rotating the engine at medium rotational speed before stopping the engine.

1) Idle the engine for approximately five minutes with no load.

(The engine temperature gradually lowers.)

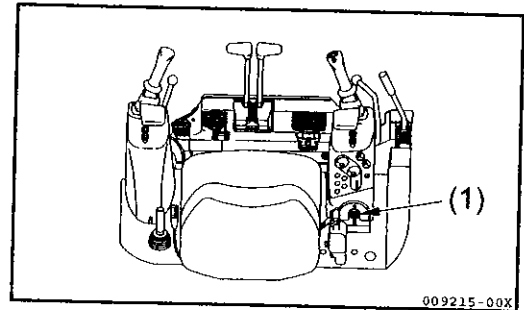

2) To stop the engine, turn the starter switch key (1) to the "OFF" position.

3) Take the key out of the starter switch (1).

### Note :

As long as the starter switch key is in "ON" position and the lock lever(s) is(are) in unlock position, each implement can be moved by its own weight when respective control levers are operated soon after the engine is stopped.

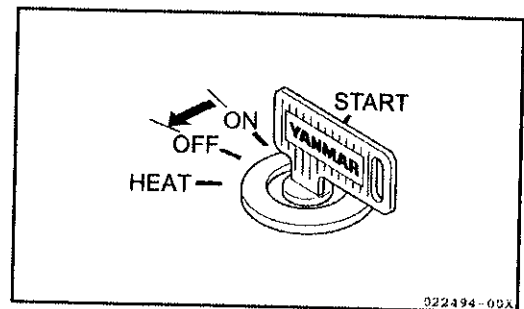

## 14. Operating Instructions

### 14-18. Inspection requirements after stopping the engine

- 1) Check oil and water for leaks, and visually inspect the implement, the machine, and the undercarriage by walking around them.  
If there are any leaks of oil or water, or any observed abnormality, take corrective action.
- 2) Completely fill the fuel oil tank.
- 3) Confirm that the engine room compartment is free of any foreign matter.  
Paper or dust in the engine room may cause fire. Remove them if any.
- 4) Remove mud adhering to the undercarriage of the machine.

### 14-19. Locking

Make sure to lock up the following parts :

- (1) Engine hood B
- (2) Engine hood rear cover
- (3) Side door (for cabin)

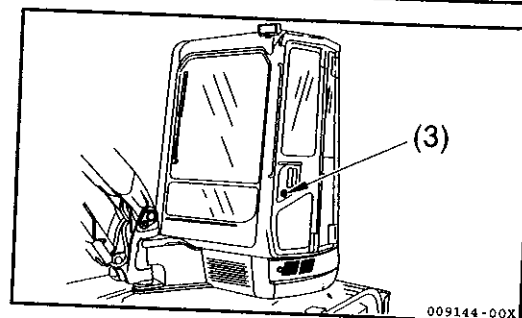
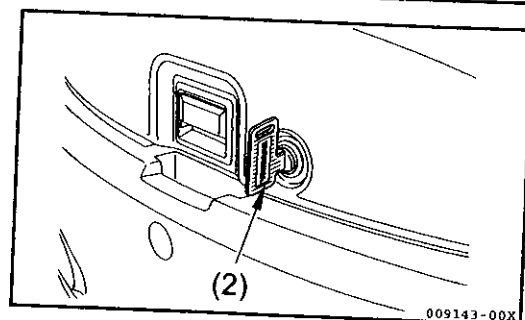
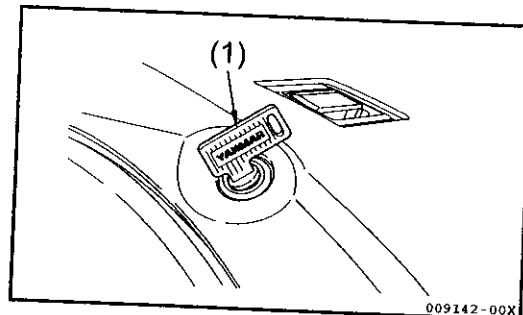

**Note :**

The starter switch key (1) is used to lock all of the parts mentioned above.

## 14-20. Handling the rubber track (for rubber track type)

### 14-20-1. Using the rubber track properly

The rubber track has some advantages over the steel track.

However, you cannot take full advantage of it if you use it in the same manner as for the steel one. Take care in operating with the rubber track according to the conditions of the work site and the type of work.

### Comparison Table of Rubber and Steel Tracks

	Rubber	Steel
Low vibration	◇	□
Smooth travel (with no creak)	◇	○
Silent travel	◇	□
Less damage to paved roads	◇	□
Simple handling	◇	□
Susceptibility to damage (strength)	□	◇
Tractive force	◇	◇

◇ : Excellent

○ : Good

□ : Ordinary

Rubber track has many advantages inherent in the unique properties of the material. On the other hand, however, it is low in strength. It is essential that you fully understand the properties of rubber track, and observe the precautions for operating and handling it to prolong its life and get the most out of it. Sure to read Section "14-20-3. Precautions for using the rubber track" before using it.

### 14-20-2. Warranty for rubber track

The rubber track is not warranted for free repair or replacement if it is damaged because of careless misuse by the customer, including the failure to comply with the prohibitions and the instructions for safe operation; for example, failure to check the tension of the rubber track or service the rubber track properly, or "operation of the rubber track on the edge of a steel plate, a U groove, a block or sharp rubbles and rocks, or on reinforcing bars or iron scraps, which could physically damage the rubber track".

## ***14. Operating Instructions***

---

### **14-20-3. Precautions for using the rubber track**

#### **■ Prohibitions**

Observe the following prohibitions:

- Do not operate or swing on sharp stones, a hard, uneven rock base, or around steel rods, scrap iron, or edges of iron plates. Failure to observe these prohibitions may damage the rubber track.
- Do not operate the machine on a stony surface like a riverbed. Doing this may damage the rubber track by catching gravel in the track or may cause the track to come off. Forcibly pushing obstacles with the track slipped will shorten the life of the rubber track.
- Prevent the rubber from getting exposed to oil, fuel, or chemical solvents. If it is exposed, immediately wipe it. Also, do not travel on a road which has an oil pool.
- When storing the rubber track for a long time period (more than three months), avoid placing it in a place subject to direct exposure to sunlight or rain.
- Do not operate the machine on heated places such as in an open-air fire, on a steel plate exposed to the blazing sun, or on a hot asphalt road.
- Never run on one rubber track while the other is held above the ground with the implement. Doing this may damage the rubber track or cause it to come off.

**14-20-4. Other precautions for using the rubber track**

Observe the following precautions when operating the machine:

- Never spin-turn on concrete or asphalt roads.
- Do not change course suddenly. Doing this will cause the rubber track to wear early or be damaged.
- Do not swing on the ground over a large level gap. Remember that running over a level gap at a right angle will prevent the track from coming off.
- Slowly lower the machine after it has been lifted above the ground with the implement.
- It is not recommended that the machine be used to handle any materials that become oily after being crushed (e.g., soybeans, corn, rapeseed oil seeds, etc.). After unavoidably using the machine to handle such materials, fully clean the machine with water.
- It is not recommended that the machine is used to handle materials such as salt, ammonium sulfate, potassium chloride, potassium sulfate, or superbiphosphate of lime. Handling these materials may affect the core metal adversely. After using the machine to handle such materials, fully clean with water.
- Do not operate the machine at the seashore. Doing this may affect the core metal adversely due to the salt content.
- If the rubber track is cracked, it could be easily damaged when handling salt, sugar, wheat, or soybeans. Be sure to repair any cracks in the rubber track to prevent rubber chips from getting into the materials being handled.
- Do not allow the rubber track to rub against a concrete wall.
- The rubber track is prone to slipping on snow or on a frozen road. Be careful of skidding when traveling or operating on a slope in cold weather.
- Operating the machine in extremely cold weather will deteriorate the rubber track, shortening its life.
- Use the rubber track between -13°F to +131°F (-25°C to +55°C) because of the physical characteristics of rubber.
- Be careful not to damage the rubber track with the bucket while operating the machine.

## 14. Operating Instructions

- Keep the track in appropriate tension to prevent it from coming off.  
If the tension is too low, the rubber track may come off under the following conditions.  
Even if the tension is adequate, take care when operating the track.

- Do not steer the machine on a large level gap created by a curbstone or a rock [approximately more than 7.87 in. (20 cm)]. Run over a level gap at a right angle to prevent the track from coming off.

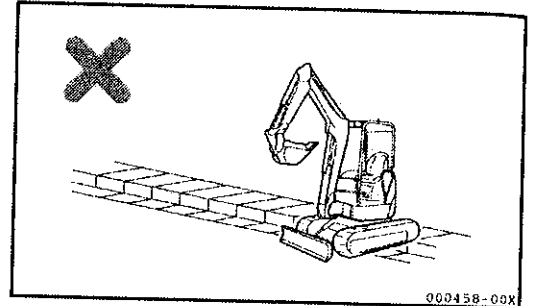

- Do not steer the machine to a boundary between the flat ground and a slope while moving backward.  
If such steering is not avoidable, slow down the speed.

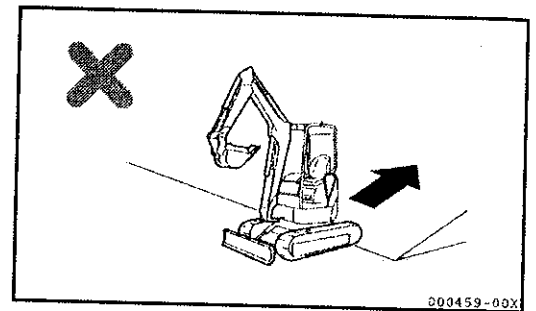

- Do not travel with the track at one end on a slope or on convex ground (at a machine inclination angle of approximately more than 10 degrees), with the track at the other end on flat ground, to prevent the rubber track from being damaged. Be sure to travel with the track at both ends on the same level surface.

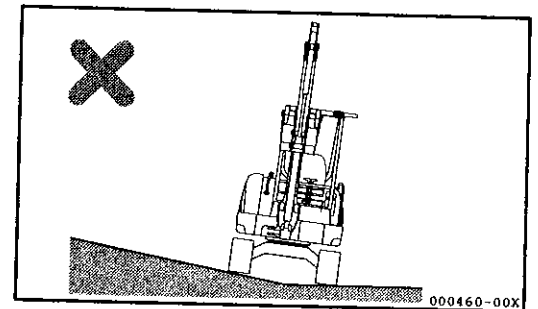

- The three cases illustrated above are those which could cause the rubber track to loosen. In addition, do not steer the machine under such ground conditions as illustrated in the right figure.

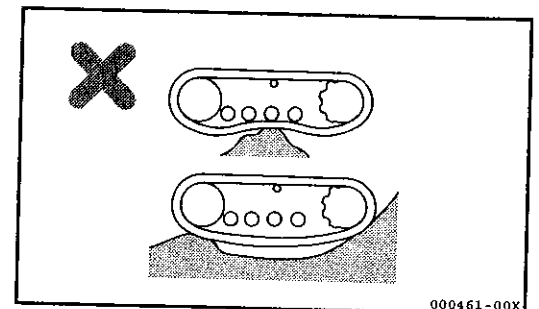

### [How the rubber track comes off]

- 1) When running over a level gap, a clearance is created between the track and the track rollers. At this point, the track tends to come off.

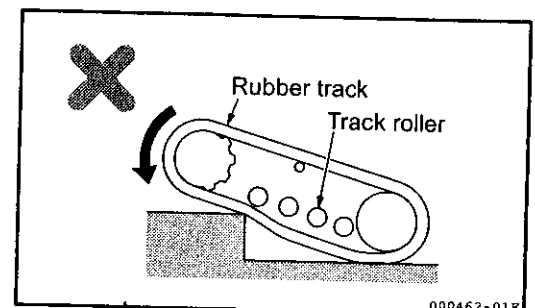

2) If the machine further travels in reverse, clearance may also be created between the track rollers and the idler and, the rubber track, causing the rubber track to easily come off.

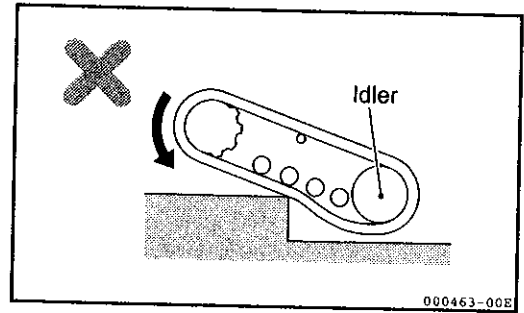

- When the machine is steered while the rubber track is blocked in the transverse direction by an obstacle or the like.

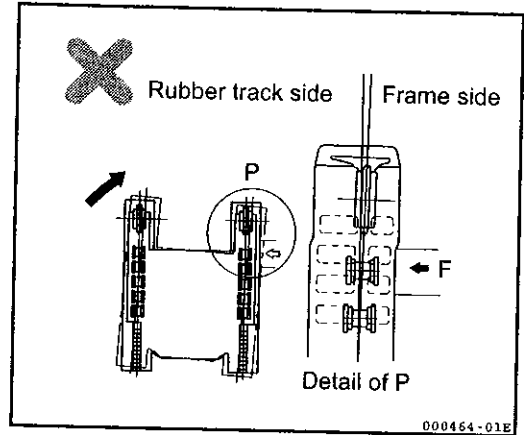

- When the idler and the track rollers are misaligned from the core metal due to rubber track misalignment.

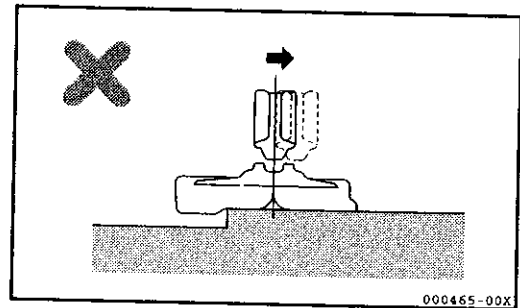

- Traveling in reverse under this condition will cause the rubber track to come off.

- Steering the machine under this condition will cause the rubber track to come off.

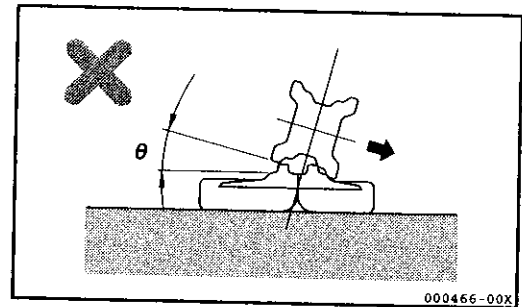

#### 14-20-5. Checking and servicing the machine with rubber track

To check and service the machine with rubber track, refer to and follow Section "26-1. Table of service time intervals".

## 14. Operating Instructions

### 14-21. Handling hydraulic P.T.O.

#### 14-21-1. Description of stop valve, P.T.O. selector valve, P.T.O. pedal and pedal lock

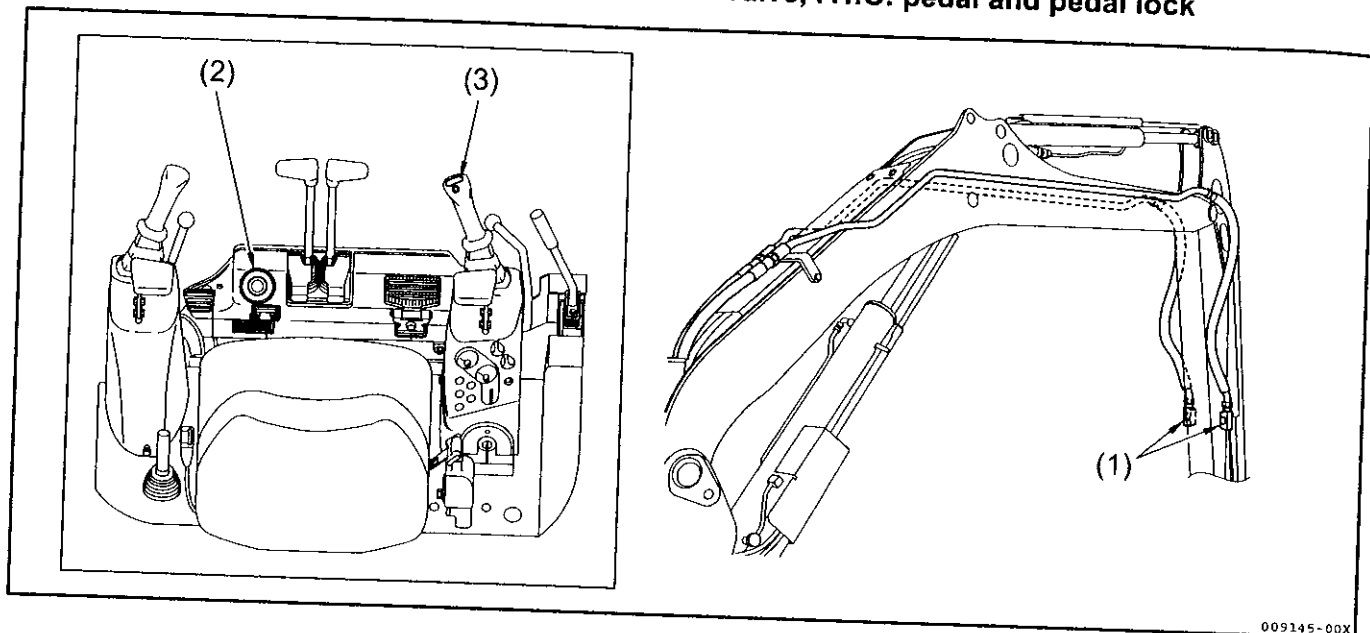

#### (1) Stop valve

This valve can stop the flow of the hydraulic oil.

(A) Open : The hydraulic oil flows

(B) Close: The hydraulic oil stops.

Set this valve at the closed position when removing and installing an attachment.

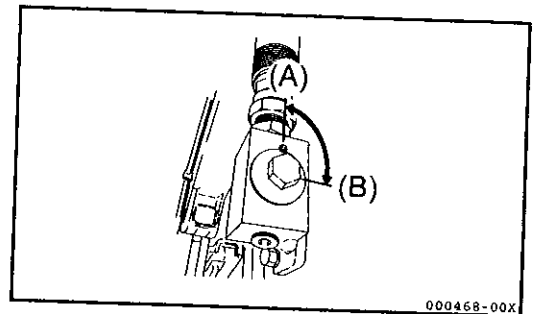

#### P.T.O. selector valve

##### (2) Foot switch

Unfold the foot rest and press the foot switch to operate a single acting attachment.

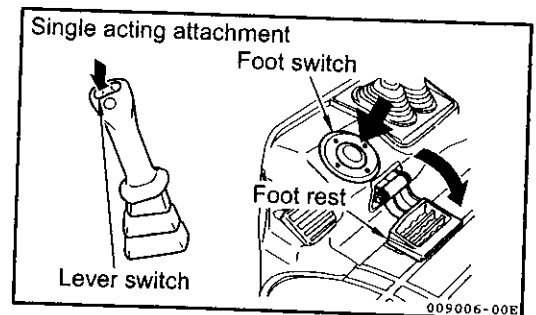

##### (3) Lever switch

Use the right hand lever switch to control attachments.

- Single acting attachment (hammer)

Operate the lever switch to the left side only (or operate the foot switch).

- Double acting attachment (tilt bucket, auger, etc.)

Operate the lever switch to right and left sides.

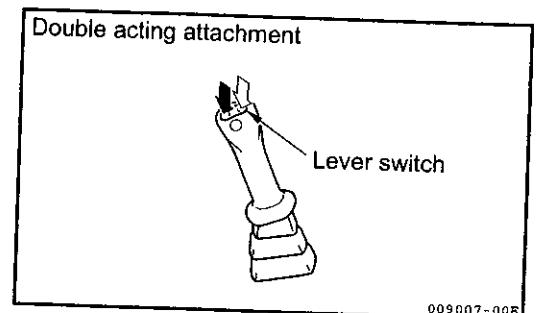



**14-21-2. Hydraulic circuit**

- 1) When mounting any attachment, follow the procedure below to connect the circuit.
  - (1) Make sure the stop valves are in the closed position and remove the screw plugs. Take care not to loose or damage the removed parts.
  - (2) Install the connectors supplied by the manufacturer of the attachment and connect the hoses.

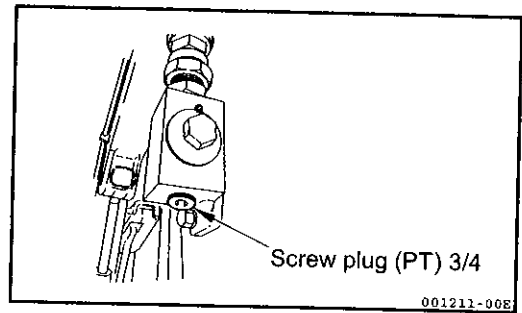
**Oil flow system**

The directions of lever switch operation and the oil flow system are described in the figure below.

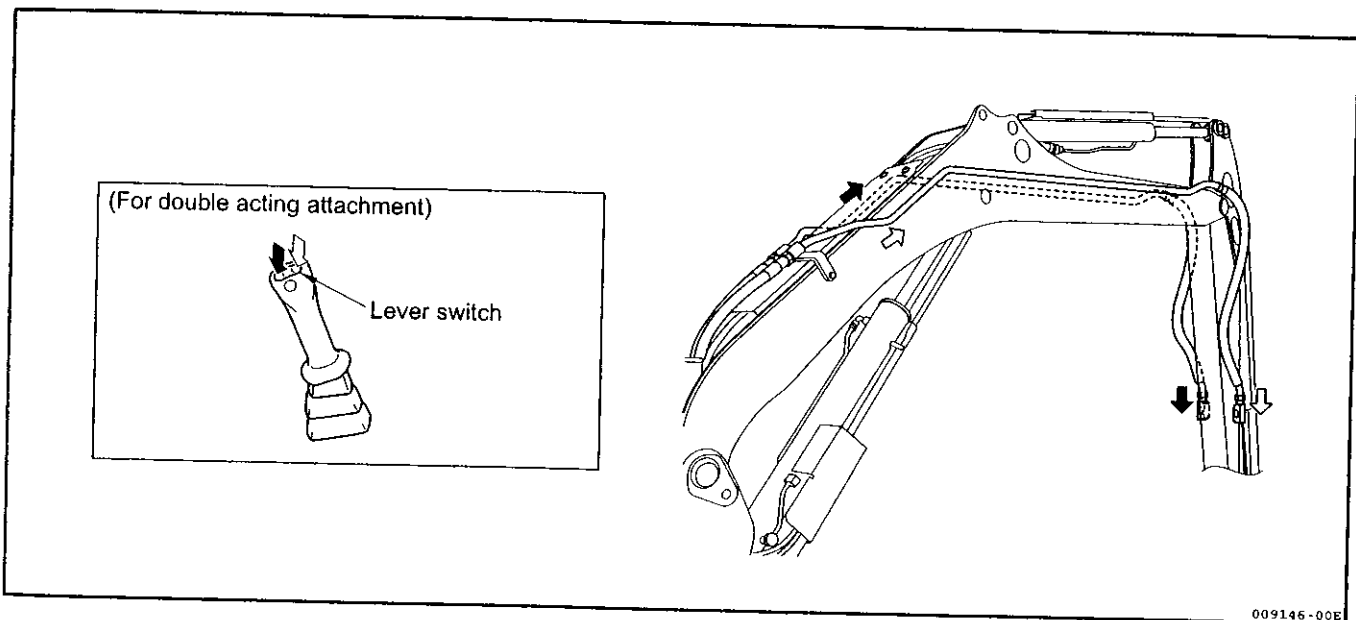

- 2) Before disconnecting the hydraulic piping to remove an attachment, relieve the hydraulic oil pressure in the circuit according to the following procedure.
  - (1) Stop the engine.
  - (2) Turn the starter key to "ON" position.
  - (3) Push the lock lever forward to set it in unlock position.
  - (4) Alternatively press the right and left sides of the lever switch several times.

## 14. Operating Instructions

### 14-21-3. Operating attachment

#### **WARNING**

When changing the hydraulic piping connection, stop the engine and slowly loosen the connection to release the inner pressure.

If you use the oil pressure for other hydraulic devices as the power source, connect the piping by using the following procedure after the engine has stopped.

- 1) Close the stop valve.
- 2) Remove the screw plugs.
- 3) Connect the hose for the hydraulic tool.
- 4) Open the stop valve.

Operate the attachment as follows:

#### ■ Precautions

- Make sure the stop valves are in the open position.  
Refer to Section "14-21-2. Hydraulic circuit" for oil flow system.

- 1) When using the breaker (single acting attachment)

Set the return line selector valve inside of the cover to the single acting attachment position.

The breaker works when the lever switch or foot switch is operated.

- Make proper use of the breaker following the handling instructions in the operation manual provided by the manufacturer of the breaker.

- 2) When using general attachments such as tilt bucket

Set the return line selector valve to the double acting attachment position.

Move the lever switch to operate the attachment.

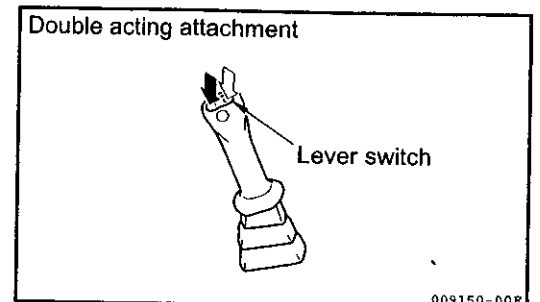
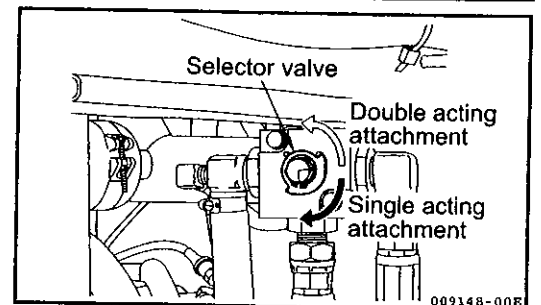
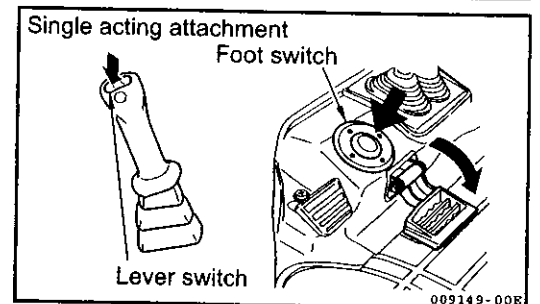
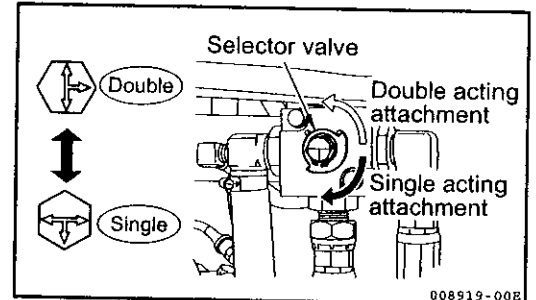
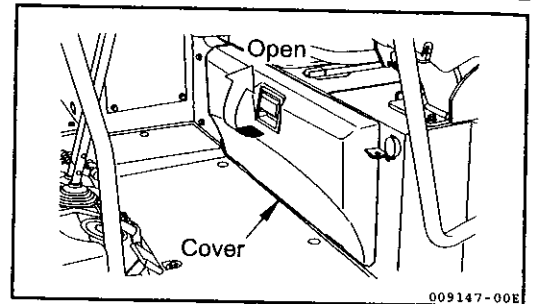
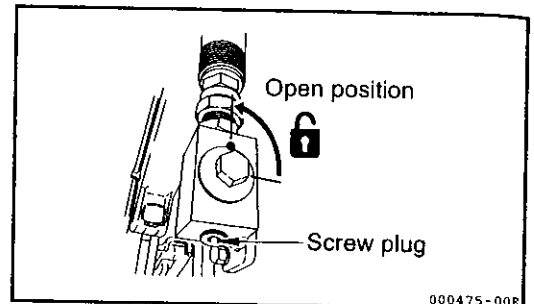

### ■ Precautions

- Make proper use of the general attachments following the handling instructions in the operation manual provided by the manufacturer of the general attachments.

#### 14-21-4. Long-term storage

If the hydraulic tool is not used, do the followings:

- Close the stop valves.
- Disconnect the hoses for the hydraulic tool. Wind the screw plug R (PT) 3/4 with seal tape and tighten them to the stop valve.

### **⚠ CAUTION**

Operating the P.T.O. switches when the breaker or general attachment is not mounted may cause overheating.

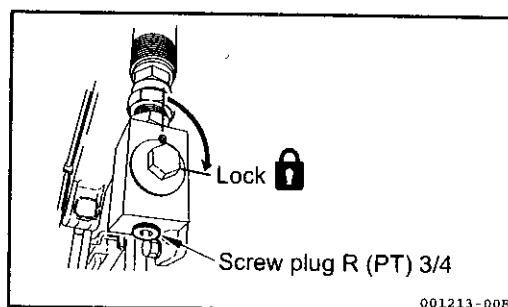

#### 14-21-5. Specification

Hydraulic oil pressure specification

- Oil flow rate
  - ViO45-5B : 21.1 GPM (80 L / min)
  - ViO55-5B : 21.1 GPM (80 L / min)

14-22. Replacing the bucket without the quick coupler

**⚠ WARNING**

- When driving pins into the bucket with a hammer, metal chips may fly. If metal chips should get into your eyes, they can cause serious injury. Use goggles, a hard hat, and gloves for safety when replacing the bucket.
- After removing the bucket, place it on solid ground in a stable position.
- When aligning the holes for pin A and pin B, be careful not to insert your fingers into those holes to prevent serious injury to your fingers. Visually check the alignment of the holes.

Work on level ground with good footing. If two or more persons work together, communicate with signals selected beforehand for safety.

■ Replacement procedure

Replace the bucket according to the following procedure:

- 1) Park the machine on level, flat ground, and lower the bucket onto the ground.
- 2) Stop the engine.
- 3) Clean around the bucket pin to prevent foreign material from entering the pin holes.
- 4) Remove pins A and B.

**IMPORTANT**

- Keep the pins away from dirt or mud.
- The machines have dust seals on either end of the bushing. Be careful not to damage them.

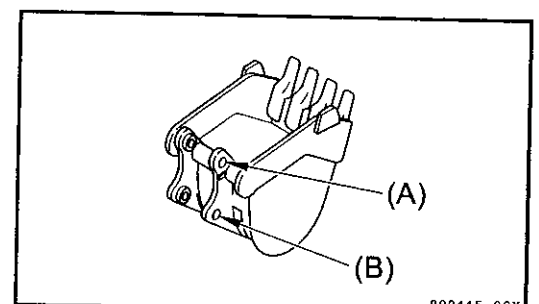
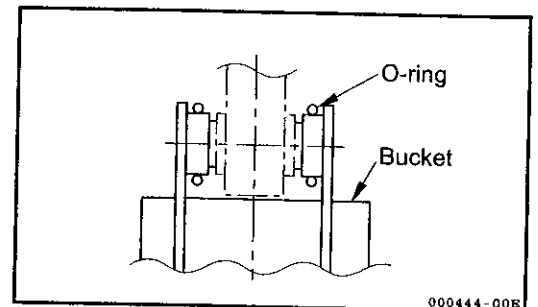
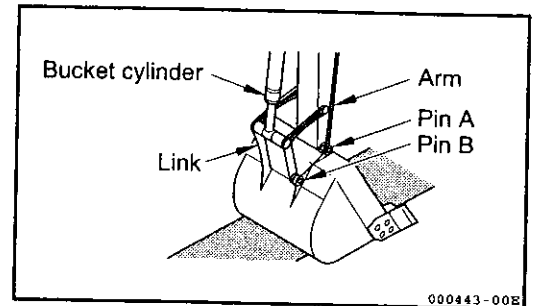

5) Clean the bucket boss section and install the O-ring.

**IMPORTANT**

- Check that the O-ring is not damaged. If it is damaged, replace it.
- We recommend that you replace the O-ring when you replace the bucket.

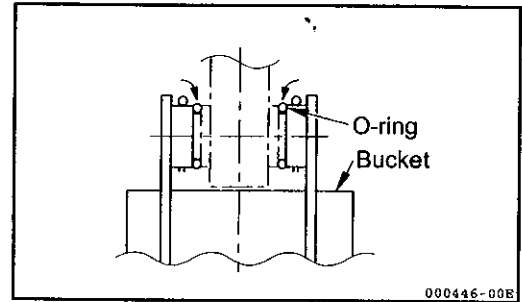

6) Connect the arm to hole (A), and then connect the link to hole (B).

7) Install the O-ring in position.

**IMPORTANT**

Before mounting the bucket, clean the arm pin hole and grease it.

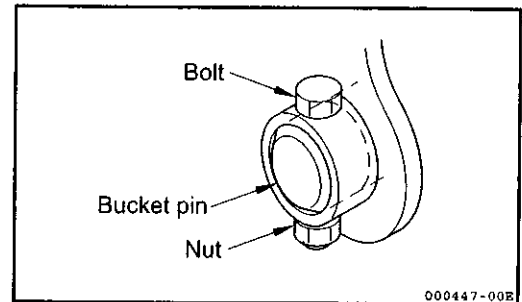

8) Install the bolt into the bucket pins A and B.

9) Grease the connecting parts.