

**CX37C**  
Mini Excavator

**SERVICE MANUAL**

**Part number 48127449**

English  
May 2017





## **SERVICE MANUAL**

**CX37C Cab - Tier IV final engine**  
**CX37C Canopy - Tier IV final engine**

# Contents

---

## INTRODUCTION

Engine.....	10
[10.001] Engine and crankcase .....	10.1
[10.106] Valve drive and gears .....	10.2
[10.101] Cylinder heads .....	10.3
[10.105] Connecting rods and pistons.....	10.4
[10.103] Crankshaft and flywheel.....	10.5
[10.216] Fuel tanks .....	10.6
[10.206] Fuel filters .....	10.7
[10.218] Fuel injection system.....	10.8
[10.202] Air cleaners and lines .....	10.9
[10.501] Exhaust Gas Recirculation (EGR) exhaust treatment.....	10.10
[10.400] Engine cooling system .....	10.11
[10.414] Fan and drive .....	10.12
[10.304] Engine lubrication system.....	10.13
Hydraulic systems.....	35
[35.000] Hydraulic systems.....	35.1
[35.106] Variable displacement pump .....	35.2
[35.359] Main control valve.....	35.3
[35.357] Pilot system .....	35.4
[35.355] Hydraulic hand control .....	35.5
[35.356] Hydraulic foot control.....	35.6
[35.352] Hydraulic swing system .....	35.7
[35.353] Hydraulic travel system .....	35.8
[35.354] Hydraulic central joint .....	35.9
[35.736] Boom hydraulic system .....	35.10
[35.737] Dipper hydraulic system.....	35.11

[35.738] Excavator and backhoe bucket hydraulic system .....	35.12
[35.739] Swing arm hydraulic system .....	35.13
[35.741] Dozer blade cylinders .....	35.14
<b>Frames and ballasting .....</b>	<b>39</b>
[39.140] Ballasts and supports .....	39.1
<b>Tracks and track suspension .....</b>	<b>48</b>
[48.130] Track frame and driving wheels .....	48.1
[48.100] Tracks .....	48.2
[48.134] Track tension units .....	48.3
[48.138] Track rollers .....	48.4
<b>Electrical systems .....</b>	<b>55</b>
[55.000] Electrical system .....	55.1
[55.100] Harnesses and connectors .....	55.2
[55.525] Cab engine controls .....	55.3
[55.015] Engine control system .....	55.4
[55.201] Engine starting system .....	55.5
[55.301] Alternator .....	55.6
[55.302] Battery .....	55.7
[55.011] Fuel tank system .....	55.8
[55.014] Engine intake and exhaust system .....	55.9
[55.012] Engine cooling system .....	55.10
[55.013] Engine oil system .....	55.11
[55.512] Cab controls .....	55.12
[55.524] Cab controls (Lift arm, Boom, Dipper, Bucket) .....	55.13
[55.518] Wiper and washer system .....	55.14
[55.404] External lighting .....	55.15
[55.405] External lighting switches and relays .....	55.16
[55.514] Cab lighting .....	55.17

[55.408] Warning indicators, alarms, and instruments .....	55.18
<b>Booms, dippers, and buckets .....</b>	<b>84</b>
[84.114] Boom pivoting support .....	84.1
[84.910] Boom .....	84.2
[84.912] Dipper arm .....	84.3
[84.100] Bucket.....	84.4
<b>Platform, cab, bodywork, and decals .....</b>	<b>90</b>
[90.100] Engine hood and panels .....	90.1
[90.105] Machine shields and guards .....	90.2



## **INTRODUCTION**

# Contents

---

## INTRODUCTION

Foreword - Important notice regarding equipment servicing .....	3
Safety rules .....	4
Safety rules - General information .....	5
Safety rules - Personal safety .....	6
Safety rules - Ecology and the environment .....	9
Torque - Standard torque settings .....	10
Torque - Special torque settings .....	12
Basic instructions - Shop and assembly .....	13
Machine specifications .....	15
Weights .....	18
Dimensions .....	19
Conversion factors .....	22
Hydraulic contamination .....	34
General specification .....	35
Fluids and lubricants .....	37
Product identification .....	41
Product identification - Machine orientation .....	44

---

## **Foreword - Important notice regarding equipment servicing**

All repair and maintenance work listed in this manual must be carried out only by qualified dealership personnel, strictly complying with the instructions given, and using, whenever possible, the special tools.

Anyone who performs repair and maintenance operations without complying with the procedures provided herein shall be responsible for any subsequent damages.

The manufacturer and all the organizations of its distribution chain, including - without limitation - national, regional, or local dealers, reject any responsibility for damages caused by parts and/or components not approved by the manufacturer, including those used for the servicing or repair of the product manufactured or marketed by the manufacturer. In any case, no warranty is given or attributed on the product manufactured or marketed by the manufacturer in case of damages caused by parts and/or components not approved by the manufacturer.

The manufacturer reserves the right to make improvements in design and changes in specifications at any time without notice and without incurring any obligation to install them on units previously sold. Specifications, descriptions, and illustrative material herein are as accurate as known at time of publication but are subject to change without notice.

In case of questions, refer to your CASE CONSTRUCTION Sales and Service Networks.



## Safety rules

### Personal safety





This is the safety alert symbol. It is used to alert you to potential personal injury hazards. Obey all safety messages that follow this symbol to avoid possible death or injury.

Throughout this manual you will find the signal words DANGER, WARNING, and CAUTION followed by special instructions. These precautions are intended for the personal safety of you and those working with you.

Read and understand all the safety messages in this manual before you operate or service the machine.

 DANGER indicates a hazardous situation that, if not avoided, will result in death or serious injury.

 WARNING indicates a hazardous situation that, if not avoided, could result in death or serious injury.

 CAUTION indicates a hazardous situation that, if not avoided, could result in minor or moderate injury.

**FAILURE TO FOLLOW DANGER, WARNING, AND CAUTION MESSAGES COULD RESULT IN DEATH OR SERIOUS INJURY.**

### Machine safety

**NOTICE:** Notice indicates a situation that, if not avoided, could result in machine or property damage.

Throughout this manual you will find the signal word Notice followed by special instructions to prevent machine or property damage. The word Notice is used to address practices not related to personal safety.

### Information

**NOTE:** Note indicates additional information that clarifies steps, procedures, or other information in this manual.

Throughout this manual you will find the word Note followed by additional information about a step, procedure, or other information in the manual. The word Note is not intended to address personal safety or property damage.

## **Safety rules - General information**

### **Cleaning**

Clean the metal parts with cleaning solution that meets the standard and steam cleaning. (except for bearings)

After cleaning, dry well, and inject oil in all parts.

Also inject oil into the bearings after drying.

### **Inspection**

When disassembling parts, check all the parts.

If there are any worn or damaged parts, replace them.

Inspect carefully to prevent initial breakdowns.

### **Bearing**

Replace any loose bearings.

Air dry bearings before installing them.

### **Needle bearing**

When inserting needle bearings, be very careful not to damage them.

Apply grease to the section where the needle bearing will be inserted.

### **Gear**

Check that there is no wear and no damage.

### **Oil seal, O-ring, gasket**

Always install new oil seals, O-rings, and gaskets.

Apply grease to sections where oil seals and O-rings will be inserted.

### **Shaft**

Check that there is no wear and no damage.

Check the bearings and check for damaged oil seals on the shaft.

### **Service parts**

Install CASE CONSTRUCTION genuine service parts.

When placing an order, check the parts catalog. It contains the CASE CONSTRUCTION genuine part numbers.

Any breakdowns arising from the installation of non-genuine parts are not covered by the warranty.

### **Lubricants (fuel, hydraulic oil)**

Use the oil from the specified company or specified in the operator's manual or service Manual.

Any breakdowns arising from any fuel or hydraulic oil other than those specified are not covered by the warranty.

## Safety rules - Personal safety

### Preliminary warnings to maintenance operation

#### **⚠ WARNING**

**Avoid injury!**

**Shut off the engine, remove the key, and make sure all machine motion stops before you service the machine.**

**Failure to comply could result in death or serious injury.**

W1128B

#### **⚠ WARNING**

**Improper operation or service of this machine can result in an accident.**

**Assign a supervisor to direct worksite operations. Agree on all safety measures, procedures, and suitable hand signals.**

**Failure to comply could result in death or serious injury.**

W0287A

#### **⚠ CAUTION**

**Pinch hazard!**

**Always use suitable tools to align mating parts. DO NOT use your hand or fingers.**

**Failure to comply could result in minor or moderate injury.**

C0044A

### Personal Protective Equipment (PPE)

#### **⚠ WARNING**

**Avoid injury!**

**Use Personal Protective Equipment (PPE), including protective goggles, gloves, and safety footwear.**

**Failure to comply could result in death or serious injury.**

W1036A

### Lifting operation

#### **⚠ WARNING**

**Crushing hazard!**

**The lifting systems must be operated by qualified personnel who are aware of the correct procedures to follow. Make sure all lifting equipment is in good condition, and all hooks are equipped with safety latches.**

**Failure to comply could result in death or serious injury.**

W0256A

#### **⚠ WARNING**

**Heavy objects!**

**Lift and handle all heavy components using lifting equipment with adequate capacity. Always support units or parts with suitable slings or hooks. Make sure the work area is clear of all bystanders.**

**Failure to comply could result in death or serious injury.**

W0398A

#### **⚠ WARNING**

**Improper operation or service of this machine can result in an accident.**

**Raised equipment or machine movement without an operator can cause serious injury. Always do the following before performing any maintenance:**

**Park the machine on flat, level ground.**

**Lower the attachment to the ground.**

**Shut down the engine and remove the ignition key.**

**Lock the tracks.**

**Failure to comply could result in death or serious injury.**

W0944D

**⚠ WARNING**

Tip-over hazard!  
Only raise the track as little as necessary.  
Failure to comply could result in death or serious injury.

W0276A

**Hydraulic system**

**⚠ WARNING**

Burn hazard!  
Before performing any service on the hydraulic system, you must allow it to cool. Hydraulic fluid temperature should not exceed 40 °C (104 °F).  
Failure to comply could result in death or serious injury.

W0241A

**⚠ WARNING**

Pressurized fluid can penetrate the skin and cause severe injuries.  
The grease in the cylinder is under high pressure. Never loosen the grease fitting adaptor completely in order to speed up the flow of grease.  
Failure to comply could result in death or serious injury.

W0261A

**⚠ WARNING**

Pressurized system!  
Before attempting any service procedure, it is your responsibility to know the number of accumulators on the machine, and the correct procedure for releasing the pressure of each accumulator.  
Failure to comply could result in death or serious injury.

W0136A

**Battery**

**⚠ WARNING**

Battery acid causes burns. Batteries contain sulfuric acid.  
Avoid contact with skin, eyes or clothing. Antidote (external): Flush with water. Antidote (eyes): flush with water for 15 minutes and seek medical attention immediately. Antidote (internal): Drink large quantities of water or milk. Do not induce vomiting. Seek medical attention immediately.  
Failure to comply could result in death or serious injury.

W0111A

**⚠ WARNING**

Battery gas can explode!  
To prevent an explosion: 1. Always disconnect the negative (-) battery cable first. 2. Always connect the negative (-) battery cable last. 3. Do not short circuit the battery posts with metal objects. 4. Do not weld, grind, or smoke near a battery.  
Failure to comply could result in death or serious injury.

W0011A

**Fluids**

**⚠ WARNING**

Hazardous chemicals!  
Coolant can be toxic. Avoid contact with skin, eyes, and clothing. Antidotes:  
EXTERNAL - Rinse thoroughly with water. Remove soiled clothing.  
INTERNAL - Rinse the mouth with water. DO NOT induce vomiting. Seek immediate medical attention.  
EYES - Flush with water. Seek immediate medical attention.  
Failure to comply could result in death or serious injury.

W0282A

**⚠ WARNING**

**Burn hazard!**

Hot coolant can spray and scald if you remove the radiator or deaeration tank cap while the system is hot. To remove the cap: allow the system to cool, turn the cap to the first notch, and wait for all pressure to release. Remove the cap only after all pressure has released.

Failure to comply could result in death or serious injury.

W0367A

**⚠ WARNING**

**Escaping fluid!**

Hydraulic fluid or diesel fuel leaking under pressure can penetrate the skin and cause infection or other injury. To prevent personal injury: Relieve all pressure before disconnecting fluid lines or performing work on the hydraulic system. Before applying pressure, make sure all connections are tight and all components are in good condition. Never use your hand to check for suspected leaks under pressure. Use a piece of cardboard or wood for this purpose. If injured by leaking fluid, see your doctor immediately.

Failure to comply could result in death or serious injury.

W0178A

**⚠ WARNING**

**Chemical hazard!**

When handling fuel, lubricants, and other service chemicals, follow the manufacturer's instructions. Wear Personal Protective Equipment (PPE) as instructed. Do not smoke or use open flame. Collect fluids in proper containers. Obey all local and environmental regulations when disposing of chemicals.

Failure to comply could result in death or serious injury.

W0371A

---

## Safety rules - Ecology and the environment

Soil, air, and water quality is important for all industries and life in general. When legislation does not yet rule the treatment of some of the substances that advanced technology requires, sound judgment should govern the use and disposal of products of a chemical and petrochemical nature.

Familiarize yourself with the relative legislation applicable to your country, and make sure that you understand this legislation. Where no legislation exists, obtain information from suppliers of oils, filters, batteries, fuels, anti-freeze, cleaning agents, etc., with regard to the effect of these substances on man and nature and how to safely store, use, and dispose of these substances.

### Helpful hints

- Avoid the use of cans or other inappropriate pressurized fuel delivery systems to fill tanks. Such delivery systems may cause considerable spillage.
- In general, avoid skin contact with all fuels, oils, acids, solvents, etc. Most of these products contain substances that may be harmful to your health.
- Modern oils contain additives. Do not burn contaminated fuels and or waste oils in ordinary heating systems.
- Avoid spillage when you drain fluids such as used engine coolant mixtures, engine oil, hydraulic fluid, brake fluid, etc. Do not mix drained brake fluids or fuels with lubricants. Store all drained fluids safely until you can dispose of the fluids in a proper way that complies with all local legislation and available resources.
- Do not allow coolant mixtures to get into the soil. Collect and dispose of coolant mixtures properly.
- The air-conditioning system contains gases that should not be released into the atmosphere. Consult an air-conditioning specialist or use a special extractor to recharge the system properly.
- Repair any leaks or defects in the engine cooling system or hydraulic system immediately.
- Do not increase the pressure in a pressurized circuit as this may lead to a component failure.
- Protect hoses during welding. Penetrating weld splatter may burn a hole or weaken hoses, allowing the loss of oils, coolant, etc.

### Battery recycling

Batteries and electric accumulators contain several substances that can have a harmful effect on the environment if the batteries are not properly recycled after use. Improper disposal of batteries can contaminate the soil, groundwater, and waterways. CASE CONSTRUCTION strongly recommends that you return all used batteries to a CASE CONSTRUCTION dealer, who will dispose of the used batteries or recycle the used batteries properly. In some countries, this is a legal requirement.



### Mandatory battery recycling

**NOTE:** The following requirements are mandatory in Brazil.

Batteries are made of lead plates and a sulfuric acid solution. Because batteries contain heavy metals such as lead, CONAMA Resolution 401/2008 requires you to return all used batteries to the battery dealer when you replace any batteries. Do not dispose of batteries in your household garbage.

Points of sale are obliged to:

- Accept the return of your used batteries
- Store the returned batteries in a suitable location
- Send the returned batteries to the battery manufacturer for recycling

## Torque - Standard torque settings

### BOLT AND NUT

Use following table for unspecified torque.

#### Coarse thread

Bolt size	Wrench	8 t	10 t
M6 x 1.0	10 mm	8.34 – 12.26 N·m (6.15 – 9.04 lb ft)	11.12 – 17.08 N·m (8.20 – 12.60 lb ft)
M8 x 1.25	13 mm	19.66 – 29.42 N·m (14.50 – 21.70 lb ft)	26.44 – 40.27 N·m (19.50 – 29.70 lb ft)
M10 x 1.5	17 mm	39.18 – 58.84 N·m (28.90 – 43.40 lb ft)	53.96 – 81.35 N·m (39.80 – 60.00 lb ft)
M12 x 1.75	19 mm	72.54 – 109.82 N·m (53.50 – 81.00 lb ft)	96.13 – 154.56 N·m (70.90 – 114.00 lb ft)
M14 x 2.0	22 mm	119.58 – 162.70 N·m (88.20 – 120.00 lb ft)	164.05 – 221.00 N·m (121.00 – 163.00 lb ft)
M16 x 2.0	24 mm	183.04 – 246.76 N·m (135.00 – 182.00 lb ft)	246.76 – 334.89 N·m (182.00 – 247.00 lb ft)
M18 x 2.5	27 mm	253.54 – 343.02 N·m (187.00 – 253.00 lb ft)	344.38 – 466.40 N·m (254.00 – 344.00 lb ft)
M20 x 2.5	30 mm	355.22 – 479.96 N·m (262.00 – 354.00 lb ft)	482.67 – 653.50 N·m (356.00 – 482.00 lb ft)
M22 x 2.5	32 mm	473.18 – 620.96 N·m (349.00 – 458.00 lb ft)	645.37 – 961.27 N·m (476.00 – 709.00 lb ft)
M24 x 3.0	36 mm	612.83 – 828.40 N·m (452.00 – 611.00 lb ft)	833.83 – 1128.04 N·m (615.00 – 832.00 lb ft)
M30 x 3.0	46 mm	1217.52 – 1645.96 N·m (898.00 – 1214.00 lb ft)	1658.17 – 2245.23 N·m (1223.00 – 1656.00 lb ft)
M36 x 4.0	55 mm	1709.69 – 2310.31 N·m (1261.00 – 1704.00 lb ft)	2451.32 – 3039.74 N·m (1808.00 – 2242.00 lb ft)

#### Fine thread

Bolt size	Wrench	8 t	10 t
M 8 x 1.0	13 mm	21.56 – 33.35 N·m (15.90 – 24.60 lb ft)	29.42 – 43.12 N·m (21.70 – 31.80 lb ft)
M10 x 1.2	17 mm	44.06 – 65.76 N·m (32.50 – 48.50 lb ft)	57.89 – 87.31 N·m (42.70 – 64.40 lb ft)
M12 x 1.25	19 mm	76.47 – 113.75 N·m (56.40 – 83.90 lb ft)	103.99 – 157.27 N·m (76.70 – 116.00 lb ft)
M14 x 1.5	22 mm	130.43 – 177.61 N·m (96.20 – 131.00 lb ft)	176.26 – 235.91 N·m (130.00 – 174.00 lb ft)
M16 x 1.5	24 mm	195.24 – 264.38 N·m (144.00 – 195.00 lb ft)	260.32 – 352.51 N·m (192.00 – 260.00 lb ft)
M18 x 1.5	27 mm	280.65 – 427.08 N·m (207.00 – 315.00 lb ft)	376.92 – 509.79 N·m (278.00 – 376.00 lb ft)
M20 x 1.5	30 mm	391.83 – 530.12 N·m (289.00 – 391.00 lb ft)	523.35 – 707.74 N·m (386.00 – 522.00 lb ft)
M22 x 1.5	32 mm	516.57 – 699.60 N·m (381.00 – 516.00 lb ft)	692.82 – 938.23 N·m (511.00 – 692.00 lb ft)
M24 x 2.0	36 mm	665.71 – 901.62 N·m (491.00 – 665.00 lb ft)	892.13 – 1206.68 N·m (658.00 – 890.00 lb ft)
M30 x 2.0	46 mm	1342.26 – 1815.44 N·m (990.00 – 1339.00 lb ft)	1781.54 – 2435.05 N·m (1314.00 – 1796.00 lb ft)
M36 x 3.0	55 mm	1884.59 – 2548.94 N·m (1390.00 – 1880.00 lb ft)	2567.92 – 3473.61 N·m (1894.00 – 2562.00 lb ft)

#### Pipe and hose (FLARE type)

Thread size (PF)	Wrench	Torque
1/4"	19 mm	39.18 N·m (28.90 lb ft)
3/8"	22 mm	49.08 N·m (36.20 lb ft)
1/2"	27 mm	93.14 N·m (68.70 lb ft)
3/4"	36 mm	176.26 N·m (130.00 lb ft)
1"	41 mm	206.08 N·m (152.00 lb ft)
1-1/4"	50 mm	343.02 N·m (253.00 lb ft)

#### Pipe and hose (ORFS type)

Thread size (UNF)	Wrench	Torque
9/16-18	19 mm	39.18 N·m (28.90 lb ft)
11/16-16	22 mm	49.08 N·m (36.20 lb ft)
13/16-16	27 mm	93.14 N·m (68.70 lb ft)

## INTRODUCTION

<b>Thread size (UNF)</b>	<b>Wrench</b>	<b>Torque</b>
1-3/16-12	36 mm	176.26 N·m (130.00 lb ft)
1-7/16-12	41 mm	206.08 N·m (152.00 lb ft)
1-11/16-12	50 mm	343.02 N·m (253.00 lb ft)

### Fitting

<b>Thread size</b>	<b>Wrench</b>	<b>Torque</b>
1/4"	19 mm	39.18 N·m (28.90 lb ft)
3/8"	22 mm	49.08 N·m (36.20 lb ft)
1/2"	27 mm	93.14 N·m (68.70 lb ft)
3/4"	36 mm	176.26 N·m (130.00 lb ft)
1"	41 mm	206.08 N·m (152.00 lb ft)
1-1/4"	50 mm	343.02 N·m (253.00 lb ft)



## Torque - Special torque settings

Component		Bolt size	Torque setting
Engine	Engine mounting bolt (engine–bracket)	M12 × 1.75	<b>96.3 – 155.9 N·m (71 – 115 lb ft)</b>
	Engine mounting bolt (bracket-frame)	M10 × 1.5	<b>54.2 – 81.3 N·m (40 – 60 lb ft)</b>
	Radiator mounting bolt and nut	M10 × 1.5	<b>54.2 – 81.3 N·m (40 – 60 lb ft)</b>
	Coupling mounting bolt	M10 × 1.5	<b>64.4 – 110.0 N·m (47.5 – 81.1 lb ft)</b>
Hydraulic system	Main pump mounting bolt	M12 × 1.75	<b>74.6 – 112.5 N·m (55 – 83 lb ft)</b>
	Main control valve mounting bolt	M10 × 1.5	<b>54.2 – 81.3 N·m (40 – 60 lb ft)</b>
	Fuel tank mounting bolt	M12 × 1.75	<b>96.3 – 155.9 N·m (71 – 115 lb ft)</b>
	Hydraulic oil tank mounting bolt	M12 × 1.75	<b>96.3 – 155.9 N·m (71 – 115 lb ft)</b>
	Turning joint mounting bolt and nut	M10 × 1.5	<b>54.2 – 81.3 N·m (40 – 60 lb ft)</b>
	Swing motor mounting bolt	M14 × 2.0	<b>164.1 – 221 N·m (121 – 163 lb ft)</b>
Power train system	Swing bearing upper mounting bolt	M12 × 1.75	<b>110.8 – 150.1 N·m (81.7 – 110.7 lb ft)</b>
	Swing bearing lower mounting bolt	M12 × 1.75	<b>110.8 – 150.1 N·m (81.7 – 110.7 lb ft)</b>
	Travel motor mounting bolt	M12 × 1.75	<b>125.8 – 145.3 N·m (92.8 – 107.2 lb ft)</b>
	Sprocket mounting bolt	M12 × 1.75	<b>108.9 – 132.5 N·m (80.3 – 97.7 lb ft)</b>
Under-carriage	Carrier roller mounting bolt and nut	M12 × 1.75	<b>108.9 – 132.5 N·m (80.3 – 97.7 lb ft)</b>
	Track roller mounting bolt	M18 × 2.0	<b>366.2 – 444.6 N·m (270.1 – 327.9 lb ft)</b>
Other systems	Counterweight mounting bolt	M20 × 2.5	<b>482.8 – 653.4 N·m (356.1 – 481.9 lb ft)</b>
	Cab mounting bolt	M12 × 1.75	<b>96.1 – 155.0 N·m (70.9 – 114.3 lb ft)</b>
	Operator's seat mounting bolt	M8 × 1.25	<b>19.7 – 30.8 N·m (14.5 – 22.7 lb ft)</b>

---

## Basic instructions - Shop and assembly

### Shimming

For each adjustment operation, select adjusting shims and measure the adjusting shims individually using a micrometer, then add up the recorded values. Do not rely on measuring the entire shimming set, which may be incorrect, or the rated value shown on each shim.

### Rotating shaft seals

For correct rotating shaft seal installation, proceed as follows:

1. Before assembly, allow the seal to soak in the oil it will be sealing for at least thirty minutes.
2. Thoroughly clean the shaft and check that the working surface on the shaft is not damaged.
3. Position the sealing lip facing the fluid.

**NOTE:** *With hydrodynamic lips, take into consideration the shaft rotation direction and position the grooves so that they will move the fluid towards the inner side of the seal.*

4. Coat the sealing lip with a thin layer of lubricant (use oil rather than grease). Fill the gap between the sealing lip and the dust lip on double lip seals with grease.
5. Insert the seal in its seat and press down using a flat punch or seal installation tool. Do not tap the seal with a hammer or mallet.
6. While you insert the seal, check that the seal is perpendicular to the seat. When the seal settles, make sure that the seal makes contact with the thrust element, if required.
7. To prevent damage to the seal lip on the shaft, position a protective guard during installation operations.

### O-ring seals

Lubricate the O-ring seals before you insert them in the seats. This will prevent the O-ring seals from overturning and twisting, which would jeopardize sealing efficiency.

### Sealing compounds

Apply a sealing compound on the mating surfaces when specified by the procedure. Before you apply the sealing compound, prepare the surfaces as directed by the product container.

### Spare parts

Only use CNH Original Parts or CASE CONSTRUCTION Original Parts.

Only genuine spare parts guarantee the same quality, duration, and safety as original parts, as they are the same parts that are assembled during standard production. Only CNH Original Parts or CASE CONSTRUCTION Original Parts can offer this guarantee.

When ordering spare parts, always provide the following information:

- Machine model (commercial name) and Product Identification Number (PIN)
- Part number of the ordered part, which can be found in the parts catalog

---

## Protecting the electronic and/or electrical systems during charging and welding

To avoid damage to the electronic and/or electrical systems, always observe the following practices:

1. Never make or break any of the charging circuit connections when the engine is running, including the battery connections.
2. Never short any of the charging components to ground.
3. Always disconnect the ground cable from the battery before arc welding on the machine or on any machine attachment.
  - Position the welder ground clamp as close to the welding area as possible.
  - If you weld in close proximity to a computer module, then you should remove the module from the machine.
  - Never allow welding cables to lie on, near, or across any electrical wiring or electronic component while you weld.
4. Always disconnect the negative cable from the battery when charging the battery in the machine with a battery charger.

**NOTICE:** *If you must weld on the unit, you must disconnect the battery ground cable from the machine battery. The electronic monitoring system and charging system will be damaged if this is not done.*

5. Remove the battery ground cable. Reconnect the cable when you complete welding.

### WARNING

**Battery acid causes burns. Batteries contain sulfuric acid.**

**Avoid contact with skin, eyes or clothing. Antidote (external): Flush with water. Antidote (eyes): flush with water for 15 minutes and seek medical attention immediately. Antidote (internal): Drink large quantities of water or milk. Do not induce vomiting. Seek medical attention immediately. Failure to comply could result in death or serious injury.**

W0111A

## Special tools

The special tools that CASE CONSTRUCTION suggests and illustrate in this manual have been specifically researched and designed for use with CASE CONSTRUCTION machines. The special tools are essential for reliable repair operations. The special tools are accurately built and rigorously tested to offer efficient and long-lasting operation.

By using these tools, repair personnel will benefit from:

- Operating in optimal technical conditions
- Obtaining the best results
- Saving time and effort
- Working in safe conditions

## Machine specifications

### Engine

Model	Yanmar 3TNV88F-ESHYB
Type	4-cycle vertical overhead valve, diesel fuel
Cooling method	Water cooling
Number of cylinders and arrangement	3 cylinders, in-line
Firing order	1 - 3 - 2
Combustion chamber type	Direct injection type
Cylinder bore x stroke	<b>88 mm (3.46 in) x 90 mm (3.54 in)</b>
Piston displacement	<b>1642 cm<sup>3</sup> (100.2 in<sup>3</sup>)</b>
Compression ratio	19.1 : 1
Rated gross horse power ( SAE J1995)	<b>18.2 kW (24.7 Hp) at 2200 RPM</b>
Maximum torque at <b>1200 RPM</b>	<b>84.3 – 94.1 N·m (62.2 – 69.4 lb ft)</b>
Engine oil quantity	<b>6.7 L (1.8 US gal)</b>
Dry weight	<b>172 kg (379 lb)</b>
High idling speed	<b>2280 – 2380 RPM</b>
Low idling speed	<b>1150 – 1250 RPM</b>
Rated fuel consumption	177 g/Hp·hr at 2200 RPM
Starting motor	<b>12 V, 2.3 kW</b>
Alternator	<b>12 V, 55 A</b>
Battery	1 x <b>12 V x 70 A·h ( 20 h rating)</b>

### Main pump

Type	Variable displacement tandem axis piston pumps
Capacity	2 x <b>17 cm<sup>3</sup>/rev (1.0 in<sup>3</sup>/rev)</b>
Maximum pressure	<b>22553 kPa (3271 psi)</b>
Rated oil flow	2 x <b>37.4 L/min (9.9 US gpm)</b>
Rated speed	<b>2200 RPM</b>

### Gear pump

Type	Fixed displacement gear pump single stage
Capacity	<b>4.5 – 10.5 cm<sup>3</sup>/rev (0.3 – 0.6 in<sup>3</sup>/rev)</b>
Maximum pressure	<b>3923 – 20105 kPa (569 – 2916 psi)</b>
Rated oil flow	<b>9.9 – 23.1 L/min (2.6 – 6.1 US gpm)</b>

### Main control valve

Type	Sectional, 10 spools (11 blocks)
Operating method	Hydraulic pilot system
Main relief valve pressure : P1, P2 / P3	<b>20105 – 22553 kPa (2916 – 3271 psi)</b>
Overload relief valve pressure	<b>24518 kPa (3556 psi)</b>

### Swing motor

Type	Fixed displacement axial piston motor
Capacity	<b>22 cm<sup>3</sup>/rev (1.3 in<sup>3</sup>/rev)</b>
Relief pressure	<b>19616 kPa (2845 psi)</b>
Braking system	Automatic, spring applied hydraulic released
Braking torque	<b>90.2 N·m (66.5 lb ft)</b>
Brake release pressure	<b>1958 – 6378 kPa (284 – 925 psi)</b>
Reduction gear type	2 - stage planetary

### Travel motor

Type	Variable displacement axial piston motor
Relief pressure	<b>22553 kPa (3271 psi)</b>
Reduction gear type	2-stage planetary
Braking system	Automatic, spring applied hydraulic released
Brake release pressure	<b>1200 kPa (174 psi)</b>
Braking torque	<b>38 N·m (28 lb ft)</b>

### Remote control valve

Type	Pressure reducing type	
Operating pressure	Minimum	<b>490 kPa (71 psi)</b>
	Maximum	<b>2013 kPa (292 psi)</b>
Single operation stroke	Lever	<b>637.42 – 833.58 kPa (92.45 – 120.90 psi)</b>

### Cylinder

Boom cylinder	Bore diameter x Rod diameter x Stroke	<b>85 mm (3.3 in) x 45 mm (1.8 in) x 540 mm (21.3 in)</b>
	Cushion	Extend only
Arm cylinder	Bore diameter x Rod diameter x Stroke	<b>Ø 80 mm (3.1 in) x Ø 45 mm (1.8 in) x 585 mm (23.0 in)</b>
	Cushion	Extend and retract
Bucket cylinder	Bore diameter x Rod diameter x Stroke	<b>Ø 70 mm (2.8 in) x Ø 45 mm (1.8 in) x 510 mm (20.1 in)</b>
	Cushion	-
Boom swing cylinder	Bore diameter x Rod diameter x Stroke	<b>Ø 80 mm (3.1 in) x Ø 45 mm (1.8 in) x 400 mm (15.7 in)</b>
	Cushion	-
Dozer cylinder	Bore diameter x Rod diameter x Stroke	<b>Ø 95 mm (3.7 in) x Ø 50 mm (2.0 in) x 152 mm (6.0 in)</b>
	Cushion	-

**NOTE:** discoloration of cylinder rod can occur when the friction reduction additive of lubrication oil spreads on the rod surface.

Discoloration does not cause any harmful effect on the cylinder performance.

### Types of shoes – Steel double grouser

Shoe width	<b>300 mm (11.8 in)</b>
Ground pressure	<b>34.34 kPa (4.98 psi)</b>
Overall width	<b>1740 mm (68.5 in)</b>

### Types of shoes – Rubber track

Shoe width	<b>300 mm (11.8 in)</b>
Ground pressure	<b>33.37 kPa (4.84 psi)</b>
Overall width	<b>1740 mm (68.5 in)</b>

INTRODUCTION

---

**Number of rollers and shoes on each side**

Upper roller	1
Lower roller	4
Track shoes	44

## Weights

### Machine

Operating weight (cab version) (*)	<b>3760 kg (8289 lb)</b>
Operating weight (canopy version) (**)	<b>3620 kg (7981 lb)</b>

### Components

Upperstructure assembly	<b>1975 kg (4354.1 lb)</b>
Main frame weld assembly	<b>460 kg (1014.1 lb)</b>
Engine assembly	<b>172 kg (379.2 lb)</b>
Main pump assembly	<b>19 kg (42 lb)</b>
Main control valve assembly	<b>25 kg (55 lb)</b>
Swing motor assembly	<b>40 kg (88.2 lb)</b>
Hydraulic oil tank assembly	<b>50 kg (110 lb)</b>
Fuel tank assembly	<b>30 kg (66 lb)</b>
Boom swing post	<b>80 kg (176.4 lb)</b>
Counterweight	<b>410 kg (903.9 lb)</b>
Cab assembly	<b>210 kg (463 lb)</b>
Canopy assembly	<b>100 kg (220.5 lb)</b>
Lower chassis assembly	<b>1230 kg (2711.7 lb)</b>
Track frame weld assembly	<b>400 kg (881.8 lb)</b>
Swing bearing	<b>50 kg (110.2 lb)</b>
Travel motor assembly	<b>40 kg (88.2 lb)</b>
Turning joint	<b>15 kg (33.1 lb)</b>
Track recoil spring	<b>33.3 kg (73.4 lb)</b>
Idler	<b>22.4 kg (49.4 lb)</b>
Carrier roller	<b>7 kg (15.4 lb)</b>
Track roller	<b>11.5 kg (25.4 lb)</b>
Sprocket	<b>7 kg (15 lb)</b>
Rubber track ( <b>300 mm (11.8 in)</b> )	<b>160 kg (352.7 lb)</b>
Dozer blade assembly	<b>140 kg (308.6 lb)</b>
Front attachment assembly ( <b>2.5 m (98.425 in)</b> boom, <b>1.3 m (51.181 in)</b> arm, <b>0.11 m<sup>3</sup> (0.144 yd<sup>3</sup>)</b> SAE heaped bucket)	<b>485 kg (1069.2 lb)</b>
<b>2.5 m (98.425 in)</b> boom assembly	<b>140 kg (308.6 lb)</b>
<b>1.3 m (51.181 in)</b> arm assembly	<b>80 kg (176.4 lb)</b>
<b>0.11 m<sup>3</sup> (0.144 yd<sup>3</sup>)</b> SAE heaped bucket	<b>80 kg (176.4 lb)</b>
Boom cylinder assembly	<b>40 kg (88.2 lb)</b>
Arm cylinder assembly	<b>40 kg (88.2 lb)</b>
Bucket cylinder assembly	<b>30 kg (66.1 lb)</b>
Bucket control link assembly	<b>20 kg (44 lb)</b>
Dozer cylinder assembly	<b>30 kg (66.1 lb)</b>
Boom swing cylinder assembly	<b>30 kg (66.1 lb)</b>

(\*) Cab, boom, arm, bucket, lubricant, coolant, full fuel and hydraulic oil, without quick coupler system, rubber track. Weight tolerance:  $\pm 3\%$ .

(\*\*) Canopy, boom, arm, bucket, lubricant, coolant, full fuel and hydraulic oil, without quick coupler system, rubber track. Weight tolerance:  $\pm 3\%$ .

## Dimensions

### Cab version

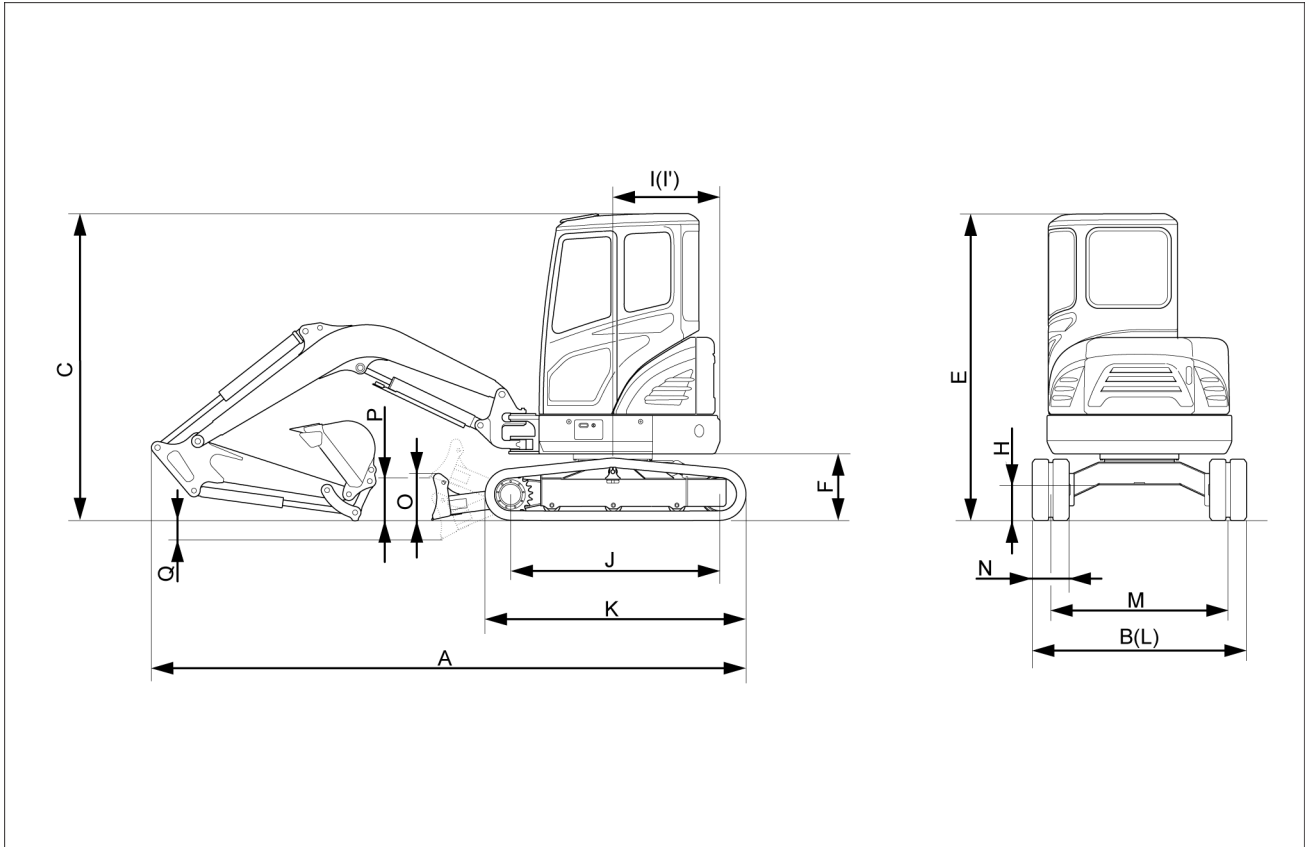

SMIL16MEX0048FA 1

<b>(A)</b> Overall length	<b>4790 mm (188.6 in)</b>
<b>(B)</b> Overall width, with <b>300 mm (11.8 in)</b> shoe	<b>1740 mm (68.5 in)</b>
<b>(C)</b> Overall height	<b>2500 mm (98.4 in)</b>
<b>(E)</b> Overall height of cab	<b>2500 mm (98.4 in)</b>
<b>(F)</b> Ground clearance of counterweight	<b>540 mm (21.3 in)</b>
<b>(H)</b> Minimum ground clearance	<b>290 mm (11.4 in)</b>
<b>(I)</b> Rear-end distance	<b>870 mm (34.3 in)</b>
<b>(I')</b> Rear-end swing radius	<b>870 mm (34.3 in)</b>
<b>(J)</b> Distance between tumbler	<b>1700 mm (66.9 in)</b>
<b>(K)</b> Undercarriage length	<b>2130 mm (83.9 in)</b>
<b>(L)</b> Undercarriage width	<b>1740 mm (68.5 in)</b>
<b>(M)</b> Track gauge	<b>1440 mm (56.7 in)</b>
<b>(N)</b> Track shoe width, standard	<b>300 mm (11.8 in)</b>
<b>(O)</b> Height of blade	<b>370 mm (14.6 in)</b>
<b>(P)</b> Ground clearance of blade up	<b>375 mm (14.8 in)</b>
<b>(Q)</b> Depth of blade down	<b>390 mm (15.4 in)</b>

Boom length: **2.5 m (98.425 in)**

Arm length: **1.3 m (51.181 in)**

With boom swing post



Canopy version

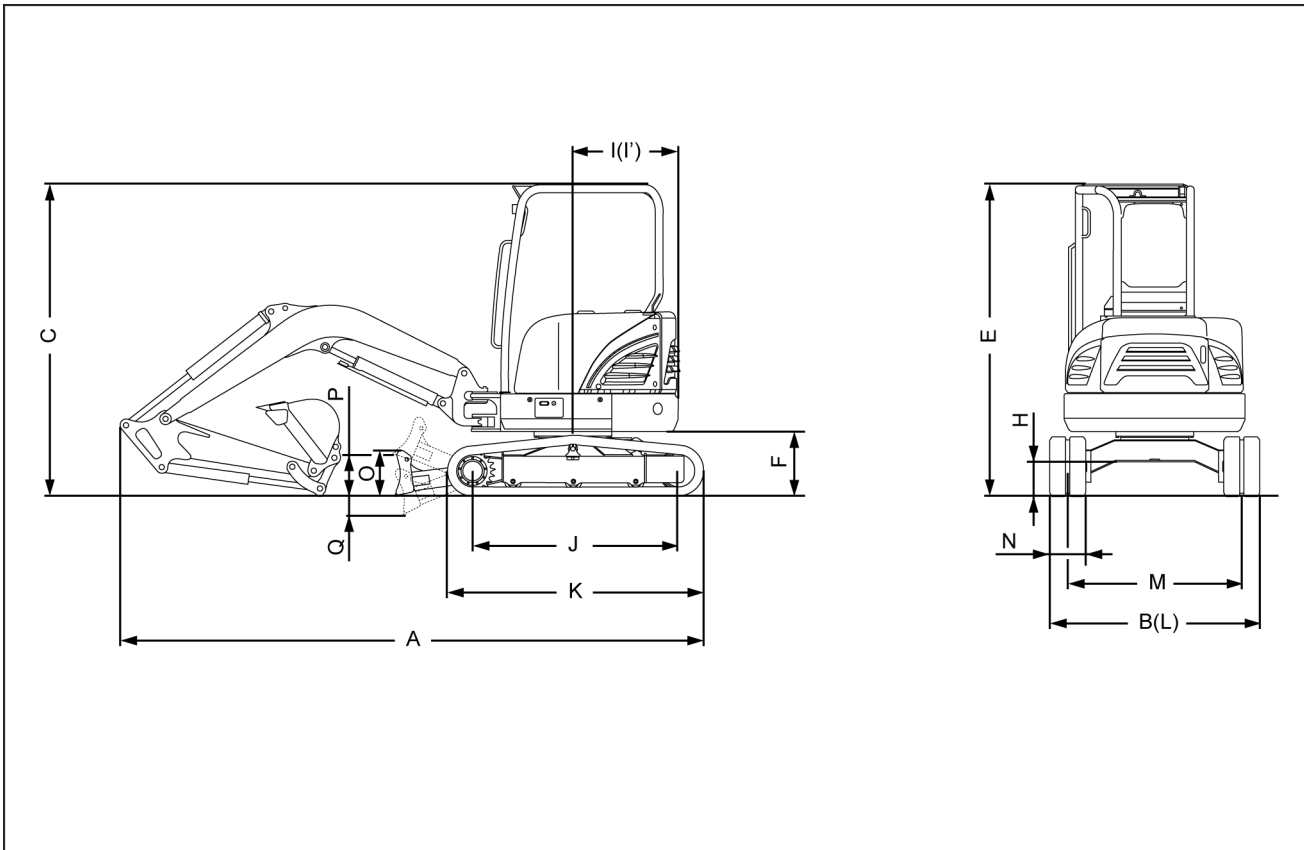

SMIL16MEX1545FA 2

<b>(A)</b> Overall length	<b>4790 mm (188.6 in)</b>
<b>(B)</b> Overall width, with <b>300 mm (11.8 in)</b> shoe	<b>1740 mm (68.5 in)</b>
<b>(C)</b> Overall height	<b>2500 mm (98.4 in)</b>
<b>(E)</b> Overall height of cab	<b>2500 mm (98.4 in)</b>
<b>(F)</b> Ground clearance of counterweight	<b>540 mm (21.3 in)</b>
<b>(H)</b> Minimum ground clearance	<b>290 mm (11.4 in)</b>
<b>(I)</b> Rear-end distance	<b>870 mm (34.3 in)</b>
<b>(I')</b> Rear-end swing radius	<b>870 mm (34.3 in)</b>
<b>(J)</b> Distance between tumblers	<b>1700 mm (66.9 in)</b>
<b>(K)</b> Undercarriage length	<b>2130 mm (83.9 in)</b>
<b>(L)</b> Undercarriage width	<b>1740 mm (68.5 in)</b>
<b>(M)</b> Track gauge	<b>1440 mm (56.7 in)</b>
<b>(N)</b> Track shoe width, standard	<b>300 mm (11.8 in)</b>
<b>(O)</b> Height of blade	<b>370 mm (14.6 in)</b>
<b>(P)</b> Ground clearance of blade up	<b>375 mm (14.8 in)</b>
<b>(Q)</b> Depth of blade down	<b>390 mm (15.4 in)</b>

Boom length: **2.5 m (98.425 in)**

Arm length: **1.3 m (51.181 in)**

With boom swing post

**Working range**

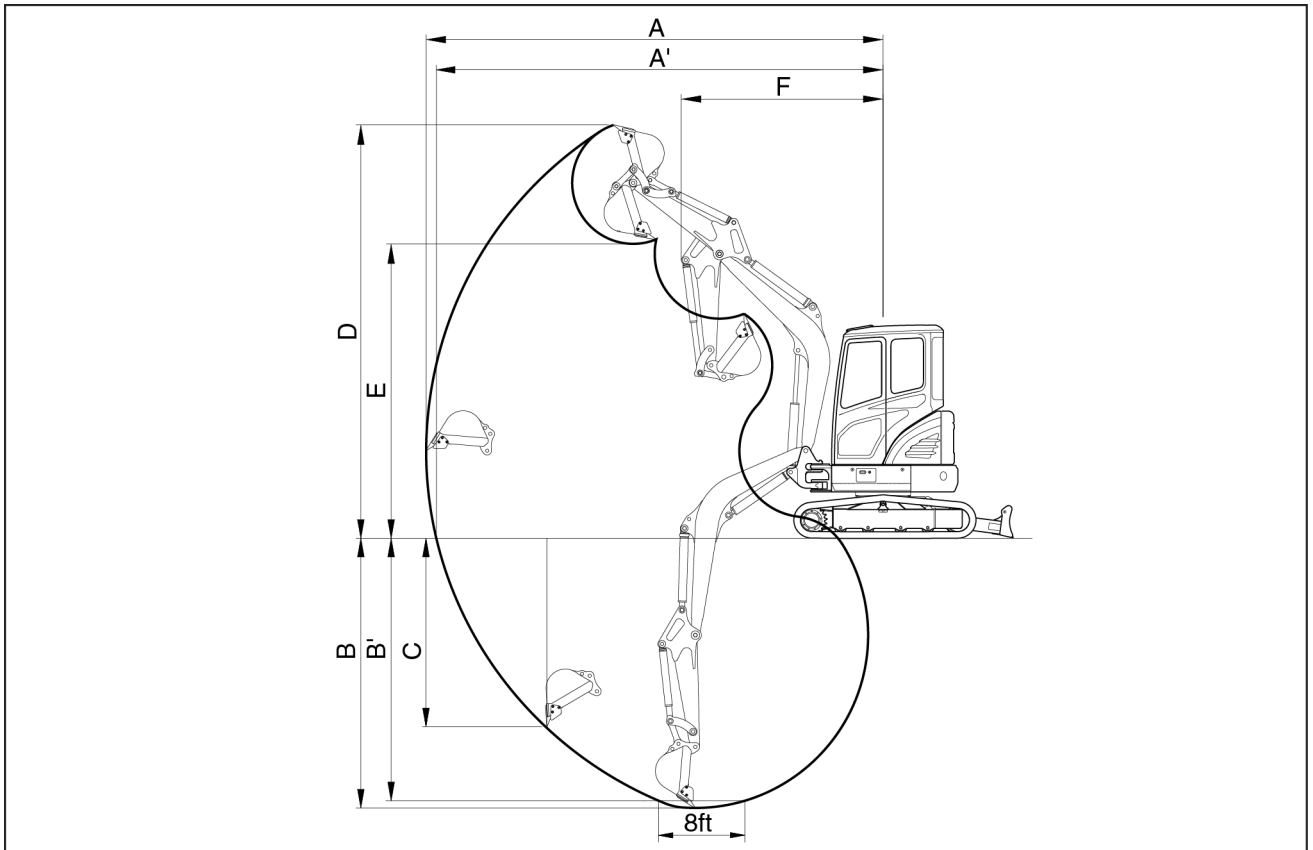

SMIL16MEX1491FA 3

<b>(A)</b> Maximum digging reach		<b>5315 mm (209.3 in)</b>
<b>(A')</b> Maximum digging reach on ground		<b>5200 mm (204.7 in)</b>
<b>(B)</b> Maximum digging depth		<b>3135 mm (123.4 in)</b>
<b>(B')</b> Maximum digging depth (8ft level)		<b>2670 mm (105.1 in)</b>
<b>(C)</b> Maximum vertical wall digging depth		<b>2190 mm (86.2 in)</b>
<b>(D)</b> Maximum digging height		<b>4810 mm (189.4 in)</b>
<b>(E)</b> Maximum dumping height		<b>3425 mm (134.8 in)</b>
<b>(F)</b> Minimum swing radius		<b>2350 mm (92.5 in)</b>
Boom swing radius (left-hand/right-hand)		<b>75° / 50°</b>
Bucket digging force	SAE	<b>27.4 kN (6159.8 lb)</b>
	ISO	<b>30.7 kN (6901.6 lb)</b>
Arm crowd force	SAE	<b>18.9 kN (4248.9 lb)</b>
	ISO	<b>19.5 kN (4383.8 lb)</b>

Boom length: **2.5 m (98.425 in)**

Arm length: **1.3 m (51.181 in)**

With boom swing post

## Conversion factors

### Unit conversion rate

Gravitational unit	- x → ← ÷ -	SI unit
kgf	9.807	N
lbf	4.448	N
kgf·cm	0.0981	N·m
lbf·ft	1.356	N·m
lbf·in	0.113	N·m
kgf/cm <sup>2</sup>	0.0981	MPa
atm	0.1013	MPa
lbf/in <sup>2</sup>	0.0069	MPa
mm Hg	133.3	Pa
in Hg	3386	Pa
kgf· m/s	0.00981	kW
lbf·ft/s	0.00136	kW
PS	0.7355	kW
HP	0.746	kW
kgf·m	9.807	J
kcal	4186	J
kgf·s/cm <sup>2</sup>	98067	Pa·s
cP	0.001	Pa·s
P	0.1	Pa·s
cSt	1 x 10 <sup>-6</sup>	m <sup>2</sup> /s
St	0.0001	m <sup>2</sup> /s

### Length

#### Millimeters to inches

mm	In.	mm	In.	mm	In.	mm	In.
1	0.0394	26	1.0236	51	2.0079	76	2.9921
2	0.0787	27	1.0630	52	2.0472	77	3.0315
3	0.1181	28	1.1024	53	2.0866	78	3.0709
4	0.1575	29	1.1417	54	2.1260	79	3.1102
5	0.1969	30	1.1811	55	2.1654	80	3.1496
6	0.2362	31	1.2205	56	2.2047	81	3.1890
7	0.2756	32	1.2598	57	2.2441	82	3.2283
8	0.3150	33	1.2992	58	2.2835	83	3.2677
9	0.3543	34	1.3386	59	2.3228	84	3.3071
10	0.3937	35	1.3780	60	2.3622	85	3.3465
11	0.4331	36	1.4173	61	2.4016	86	3.3858
12	0.4724	37	1.4567	62	2.4409	87	3.4252
13	0.5118	38	1.4961	63	2.4803	88	3.4646
14	0.5512	39	1.5354	64	2.5197	89	3.5039
15	0.5906	40	1.5748	65	2.5591	90	3.5433
16	0.6299	41	1.6142	66	2.5984	91	3.5827
17	0.6693	42	1.6535	67	2.6378	92	3.6220
18	0.7087	43	1.6929	68	2.6772	93	3.6614
19	0.7480	44	1.7323	69	2.7165	94	3.7008
20	0.7874	45	1.7717	70	2.7559	95	3.7402
21	0.8268	46	1.8110	71	2.7953	96	3.7795
22	0.8661	47	1.8504	72	2.8346	97	3.8189
23	0.9055	48	1.8898	73	2.8740	98	3.8583
24	0.9449	49	1.9291	74	2.9134	99	3.8976
25	0.9843	50	1.9685	75	2.9528	100	3.9370

INTRODUCTION

**Inches to millimeters**

in.	mm	in.	mm	in.	mm	in.	mm
1/64	0.3969	17/64	6.7469	33/64	13.0969	49/64	19.4469
1/32	0.7938	9/32	7.1438	17/32	13.4938	25/32	19.8438
3/64	1.1906	19/64	7.5406	35/64	13.8906	51/64	20.2406
1/16	1.5875	5/16	7.9375	9/16	14.2875	13/16	20.6375
5/64	1.9844	21/64	8.3344	37/64	14.6844	53/64	21.0344
3/32	2.3813	11/32	8.7313	19/32	15.0813	27/32	21.4313
7/64	2.7781	23/64	9.1281	39/64	15.4781	55/64	21.8281
1/8	3.1750	3/8	9.5250	5/8	15.8750	7/8	22.2250
9/64	3.5719	25/64	9.9218	41/64	16.2719	57/64	22.6219
5/32	3.9688	13/32	10.3188	21/32	16.6688	29/32	23.0188
11/64	4.3656	27/64	10.7156	43/64	17.0656	59/64	23.4156
3/16	4.7625	7/16	11.1125	11/16	17.4625	15/16	23.8125
13/64	5.1594	29/64	11.5094	45/64	17.8594	61/64	24.2094
7/32	5.5563	15/32	11.9063	23/32	18.2563	31/32	24.6063
15/64	5.9531	31/64	12.3031	47/64	18.6531	63/64	25.0031
1/4	6.3500	1/2	12.7000	3/4	19.0500	1	25.4000

**Feet to meters**

ft.	0	1	2	3	4	5	6	7	8	9	ft.
	m	m	m	m	m	m	m	m	m	m	
----		0.305	0.610	0.914	1.219	1.524	1.829	2.134	2.438	2.743	----
10	3.048	3.353	3.658	3.962	4.267	4.572	4.877	5.182	5.486	5.791	10
20	6.096	6.401	6.706	7.010	7.315	7.620	7.925	8.230	8.534	8.839	20
30	9.144	9.449	9.754	10.058	10.363	10.668	10.973	11.278	11.582	11.887	30
40	12.192	12.497	12.802	13.106	13.411	13.716	14.021	14.326	14.630	14.935	40
50	15.24	15.545	15.850	16.154	16.459	16.764	17.069	17.374	17.678	17.983	50
60	18.288	18.593	18.898	19.202	19.507	19.812	20.117	20.422	20.726	21.031	60
70	21.336	21.641	21.946	22.250	22.555	22.860	23.165	23.470	23.774	24.079	70
80	24.384	24.689	24.994	25.298	25.603	25.908	26.213	26.518	26.822	27.127	80
90	27.432	27.737	28.042	28.346	28.651	28.956	29.261	29.566	29.870	30.175	90
100	30.480	30.785	31.090	31.394	31.699	32.004	32.309	32.614	32.918	33.223	100

**Meters to feet**

m	0	1	2	3	4	5	6	7	8	9	m
	ft.	ft.	ft.	ft.	ft.	ft.	ft.	ft.	ft.	ft.	
----		3.2808	6.5617	9.8425	13.1234	16.4042	19.685	22.9659	26.2467	29.5276	----
10	32.8084	36.0892	39.3701	42.6509	45.9318	49.2126	52.4934	55.7743	59.0551	62.3360	10
20	65.6168	68.8976	72.1785	75.4593	78.7402	82.0210	85.3018	88.5827	91.8635	95.1444	20
30	98.4252	101.706	104.986	108.267	111.5486	114.829	118.1102	121.391	124.671	127.952	30
40	131.233	134.514	137.795	141.076	144.357	147.637	150.918	154.199	157.480	160.761	40
50	164.042	167.322	170.603	173.884	177.165	180.446	183.727	187.007	190.288	193.569	50
60	196.850	200.131	203.412	206.692	209.973	213.254	216.535	219.816	223.097	226.378	60
70	229.658	232.939	236.220	239.501	242.782	246.063	249.343	252.624	255.905	259.186	70
80	262.467	265.748	269.028	272.309	275.590	278.871	282.152	285.433	288.713	291.994	80
90	295.275	298.556	301.837	305.118	308.399	311.679	314.960	318.241	321.522	324.803	90
100	328.084	331.364	334.645	337.926	341.207	344.488	347.769	351.049	354.330	357.611	100

INTRODUCTION

**Miles to kilometers**

miles	0	1	2	3	4	5	6	7	8	9	miles
	km	km	km	km	km	km	km	km	km	km	
----		1.609	3.219	4.828	6.437	8.047	9.656	11.265	12.875	14.484	----
10	16.093	17.703	19.312	20.921	22.531	24.140	25.750	27.359	28.968	30.578	10
20	32.187	33.796	35.406	37.015	38.624	40.234	41.843	43.452	45.062	46.671	20
30	48.280	49.890	51.499	53.108	54.718	56.327	57.936	59.546	61.155	62.764	30
40	64.374	65.983	67.592	69.202	70.811	72.420	74.030	75.639	77.249	78.858	40
50	80.467	82.077	83.686	85.295	86.905	88.514	90.123	91.733	93.342	94.951	50
60	96.561	98.170	99.779	101.39	102.998	104.607	106.217	107.826	109.435	111.045	60
70	112.654	114.263	115.873	117.482	119.091	120.701	122.310	123.919	125.529	127.138	70
80	128.748	130.357	131.966	133.576	135.185	136.794	138.404	140.013	141.622	143.232	80
90	144.841	146.450	148.060	149.669	151.278	152.888	154.497	156.106	157.716	159.325	90
100	160.934	162.544	164.153	165.762	167.372	168.981	170.590	172.200	173.809	175.418	100

**Kilometers to miles**

km	0	1	2	3	4	5	6	7	8	9	km
	miles	miles	miles	miles	miles	miles	miles	miles	miles	miles	
----		0.621	1.243	1.864	2.485	3.107	3.728	4.350	4.971	5.592	----
10	6.214	6.835	7.456	8.078	8.699	9.321	9.942	10.563	11.185	11.806	10
20	12.427	13.049	13.670	14.292	14.913	15.534	16.156	16.777	17.398	18.020	20
30	18.641	19.263	19.884	20.505	21.127	21.748	22.369	22.991	23.612	24.233	30
40	24.855	25.476	26.098	26.719	27.340	27.962	28.583	29.204	29.826	30.447	40
50	31.069	31.690	32.311	32.933	33.554	34.175	34.797	35.418	36.040	36.661	50
60	37.282	37.904	38.525	39.146	39.768	40.389	41.010	41.632	42.253	42.875	60
70	43.496	44.117	44.739	45.360	45.981	46.603	47.224	47.846	48.467	49.088	70
80	49.710	50.331	50.952	51.574	52.195	52.817	53.438	54.059	54.681	55.302	80
90	55.923	56.545	57.166	57.788	58.409	59.03	59.652	60.273	60.894	61.516	90
100	62.137	62.758	63.380	64.001	64.623	65.244	65.865	66.487	67.108	67.729	100

**Area**

**Square inches to square centimeters**

in <sup>2</sup>	0	1	2	3	4	5	6	7	8	9	in <sup>2</sup>
	cm <sup>2</sup>	cm <sup>2</sup>	cm <sup>2</sup>	cm <sup>2</sup>	cm <sup>2</sup>	cm <sup>2</sup>	cm <sup>2</sup>	cm <sup>2</sup>	cm <sup>2</sup>	cm <sup>2</sup>	
----		6.452	12.903	19.355	25.806	32.258	38.710	45.161	51.613	58.065	----
10	64.516	70.968	77.419	83.871	90.323	96.774	103.226	109.677	116.129	122.581	10
20	129.032	135.484	141.935	148.387	154.839	161.290	167.742	174.194	180.645	187.097	20
30	193.548	200.000	206.452	212.903	219.355	225.806	232.258	238.710	245.161	251.613	30
40	258.065	264.516	270.968	277.419	283.871	290.323	296.774	303.226	309.677	316.129	40
50	322.581	329.032	335.484	341.935	348.387	354.839	361.290	367.742	374.194	380.645	50
60	387.097	393.548	400.000	406.452	412.903	419.355	425.806	432.258	438.710	445.161	60
70	451.613	458.065	464.516	470.968	477.419	483.871	490.323	496.774	503.226	509.677	70
80	516.129	522.581	529.032	535.484	541.935	548.387	554.839	561.290	567.742	574.194	80
90	580.645	587.097	593.548	600.000	606.452	612.903	619.355	625.806	632.258	638.710	90
100	645.161	651.613	658.065	664.516	670.968	677.419	683.871	690.323	696.774	703.226	100

INTRODUCTION

**Square centimeters to square inches**

cm <sup>2</sup>	0	1	2	3	4	5	6	7	8	9	cm <sup>2</sup>
	in <sup>2</sup>	in <sup>2</sup>	in <sup>2</sup>	in <sup>2</sup>	in <sup>2</sup>	in <sup>2</sup>	in <sup>2</sup>	in <sup>2</sup>	in <sup>2</sup>	in <sup>2</sup>	
----		0.155	0.310	0.465	0.620	0.775	0.930	1.085	1.240	1.395	----
10	1.550	1.705	1.860	2.015	2.170	2.325	2.480	2.635	2.790	2.945	10
20	3.100	3.255	3.410	3.565	3.720	3.875	4.030	4.185	4.340	4.495	20
30	4.650	4.805	4.960	5.115	5.270	5.425	5.580	5.735	5.890	6.045	30
40	6.200	6.355	6.510	6.665	6.820	6.975	7.130	7.285	7.440	7.595	40
50	7.750	7.905	8.060	8.215	8.370	8.525	8.680	8.835	8.990	9.145	50
60	9.300	9.455	9.610	9.765	9.920	10.075	10.230	10.385	10.540	10.695	60
70	10.850	11.005	11.160	11.315	11.470	11.625	11.780	11.935	12.090	12.245	70
80	12.400	12.555	12.710	12.865	13.020	13.175	13.330	13.485	13.640	13.795	80
90	13.950	14.105	14.260	14.415	14.570	14.725	14.880	15.035	15.190	15.345	90
100	15.500	15.655	15.810	15.965	16.120	16.275	16.430	16.585	16.740	16.895	100

**Volume**

**Cubic inches to cubic centimeters**

in <sup>3</sup>	0	1	2	3	4	5	6	7	8	9	in <sup>3</sup>
	cm <sup>3</sup> (cc)	cm <sup>3</sup> (cc)	cm <sup>3</sup> (cc)	cm <sup>3</sup> (cc)	cm <sup>3</sup> (cc)	cm <sup>3</sup> (cc)	cm <sup>3</sup> (cc)	cm <sup>3</sup> (cc)	cm <sup>3</sup> (cc)	cm <sup>3</sup> (cc)	
----		16.387	32.774	49.161	65.548	81.936	98.323	114.710	131.097	147.484	----
10	163.871	180.258	196.645	213.032	229.419	245.807	262.194	278.581	294.968	311.355	10
20	327.742	344.129	360.516	376.903	393.290	409.678	426.065	442.452	458.839	475.226	20
30	491.613	508.000	524.387	540.774	557.161	573.549	589.936	606.323	622.710	639.097	30
40	655.484	671.871	688.258	704.645	721.033	737.420	753.807	770.194	786.581	802.968	40
50	819.355	835.742	852.129	868.516	884.904	901.291	917.678	934.065	950.452	966.839	50
60	983.226	999.613	0	7	5	2	9	6	1114.323	0	60
70	1147.09	1163.48	1179.87	1196.25	1212.64	1229.03	1245.42	1261.80	1278.19	1294.58	70
	7	4	1	8	6	3	0	7	4	1	
80	1310.96	1327.35	1343.74	1360.13	1376.51	1392.90	1409.29	1425.67	1442.06	1458.45	80
	8	5	2	0	7	4	1	8	5	2	
90	1474.83	1491.22	1507.61	1524.00	1540.38	1556.77	1573.16	1589.54	1605.93	1622.32	90
	9	6	3	1	8	5	2	9	6	3	
100	1638.71	1655.09	1671.48	1687.87	1704.25	1720.64	1737.03	1753.42	1769.80	1786.19	100
	0	7	4	2	9	6	3	0	7	4	

**Cubic centimeters to cubic inches**

cm <sup>3</sup> (cc)	0	1	2	3	4	5	6	7	8	9	cm <sup>3</sup> (cc)
	in <sup>3</sup>	in <sup>3</sup>	in <sup>3</sup>	in <sup>3</sup>	in <sup>3</sup>	in <sup>3</sup>	in <sup>3</sup>	in <sup>3</sup>	in <sup>3</sup>	in <sup>3</sup>	
----		0.0610	0.1220	0.1831	0.2441	0.3051	0.3661	0.4272	0.4882	0.5492	----
10	0.6102	0.6713	0.7323	0.7933	0.8543	0.9154	0.9764	1.0374	1.0984	1.1594	10
20	1.2205	1.2815	1.3425	1.4035	1.4646	1.5256	1.5866	1.6476	1.7087	1.7697	20
30	1.8307	1.8917	1.9528	2.0138	2.0748	2.1358	2.1968	2.2579	2.3189	2.3799	30
40	2.4409	2.5020	2.5630	2.6240	2.6850	2.7461	2.8071	2.8681	2.9291	2.9902	40
50	3.0512	3.1122	3.1732	3.2343	3.2953	3.3563	3.4173	3.4784	3.5394	3.6004	50
60	3.6614	3.7224	3.7835	3.8445	3.9055	3.9665	4.0276	4.0886	4.1496	4.2106	60
70	4.2717	4.3327	4.3937	4.4547	4.5157	4.5768	4.6378	4.6988	4.7598	4.8209	70
80	4.8819	4.9429	5.0039	5.0650	5.1260	5.1870	5.2480	5.3091	5.3701	5.4311	80
90	5.4921	5.5531	5.6142	5.6752	5.7362	5.7972	5.8583	5.9193	5.9803	6.0413	90
100	6.1024	6.1634	6.2244	6.2854	6.3465	6.4075	6.4685	6.5295	6.5905	6.6516	100

INTRODUCTION

**Gallons (U.S) to liters**

U.S.-gal.	0	1	2	3	4	5	6	7	8	9	U.S.-gal.
	liters	liters	liters	liters	liters	liters	liters	liters	liters	liters	
----		3.7853	7.5707	11.3560	15.1413	18.9266	22.7120	26.4973	30.2826	34.0680	----
10	37.8533	41.6386	45.4239	49.2093	52.9946	56.7799	60.5653	64.3506	68.1359	71.9213	10
20	75.7066	79.4919	83.2772	87.0626	90.8479	94.6332	98.4186	102.203	105.989	109.774	20
30	113.559	117.345	121.130	124.915	128.701	132.486	136.271	140.057	143.842	147.627	30
40	151.413	155.198	158.983	162.769	166.554	170.339	174.125	177.910	181.695	185.481	40
50	189.266	193.051	196.837	200.622	204.407	208.193	211.978	215.763	219.549	223.334	50
60	227.119	230.905	234.690	238.475	242.261	246.046	249.831	253.617	257.402	261.187	60
70	264.973	268.758	272.543	276.329	280.114	283.899	287.685	291.470	295.255	299.041	70
80	302.826	306.611	310.397	314.182	317.967	321.753	325.538	329.323	333.109	336.894	80
90	340.679	344.464	348.250	352.035	355.820	359.606	363.391	367.176	370.962	374.747	90
100	378.532	382.318	386.103	389.888	393.674	397.459	401.244	405.030	408.815	412.600	100

**Liters to gallons (U.S)**

liters	0	1	2	3	4	5	6	7	8	9	liters
	U.S.gal.	U.S.gal.	U.S.gal.	U.S.gal.	U.S.gal.	U.S.gal.	U.S.gal.	U.S.gal.	U.S.gal.	U.S.gal.	
----		0.2642	0.5284	0.7925	1.0567	1.3209	1.5851	1.8492	2.1134	2.3776	----
10	2.6418	2.9060	3.1701	3.4343	3.6985	3.9627	4.2268	4.4910	4.7552	5.0194	10
20	5.2836	5.5477	5.8119	6.0761	6.3403	6.6044	6.8686	7.1328	7.3970	7.6612	20
30	7.9253	8.1895	8.4537	8.7179	8.9820	9.2462	9.5104	9.7746	10.0388	10.3029	30
40	10.5671	10.8313	11.0955	11.3596	11.6238	11.8880	12.1522	12.4164	12.6805	12.9447	40
50	13.2089	13.4731	13.7372	14.0014	14.2656	14.5298	14.7940	15.0581	15.3223	15.5865	50
60	15.8507	16.1148	16.3790	16.6432	16.9074	17.1716	17.4357	17.6999	17.9641	18.2283	60
70	18.4924	18.7566	19.0208	19.2850	19.5492	19.8133	20.0775	20.3417	20.6059	20.8700	70
80	21.1342	21.3984	21.6626	21.9268	22.1909	22.4551	22.7193	22.9835	23.2476	23.5118	80
90	23.7760	24.0402	24.3044	24.5685	24.8327	25.0969	25.3611	25.6252	25.8894	26.1536	90
100	26.4178	26.6820	26.9461	27.2103	27.4745	27.7387	28.0028	28.2670	28.5312	28.7954	100

INTRODUCTION

**Gallons (Imp.) to liters**

Imp-gal.	0	1	2	3	4	5	6	7	8	9	Imp-gal.
	liters	liters	liters	liters	liters	liters	liters	liters	liters	liters	
----		4.5455	9.0909	13.6364	18.1818	22.7273	27.2727	31.8182	36.3636	40.9091	----
10	45.4545	50.0000	54.5455	59.0909	63.6364	68.1818	72.7273	77.2727	81.8182	86.3636	10
20	90.9091	95.4545	0	5	9	4	8	3	7	2	20
30	136.3636	140.9091	145.4545	150.0000	154.5455	159.0909	163.6364	168.1818	172.7273	177.2727	30
40	181.8182	186.3637	190.9092	195.4547	200.0002	204.5457	209.0912	213.6367	218.1822	222.7277	40
50	227.2727	231.8182	236.3637	240.9092	245.4547	250.0002	254.5457	259.0912	263.6367	268.1822	50
60	272.7272	277.2727	281.8182	286.3637	290.9092	295.4547	300.0002	304.5457	309.0912	313.6367	60
70	318.1818	322.7273	327.2728	331.8183	336.3638	340.9093	345.4548	350.0003	354.5458	359.0913	70
80	363.6364	368.1819	372.7274	377.2729	381.8184	386.3639	390.9094	395.4549	400.0004	404.5459	80
90	409.0910	413.6365	418.1820	422.7275	427.2730	431.8185	436.3640	440.9095	445.4550	450.0000	90
100	454.5455	459.0910	463.6365	468.1820	472.7275	477.2730	481.8185	486.3640	490.9095	495.4550	100

**Liters to gallons (Imp.)**

liters	0	1	2	3	4	5	6	7	8	9	liters
	Imp-gal.	Imp-gal.	Imp-gal.	Imp-gal.	Imp-gal.	Imp-gal.	Imp-gal.	Imp-gal.	Imp.	Imp-gal.	
----		0.2200	0.4400	0.6600	0.8800	1.1000	1.3200	1.5400	1.7600	1.9800	----
10	2.2000	2.4200	2.6400	2.8600	3.0800	3.3000	3.5200	3.7400	3.9600	4.1800	10
20	4.4000	4.6200	4.8400	5.0600	5.2800	5.5000	5.7200	5.9400	6.1600	6.3800	20
30	6.6000	6.8200	7.0400	7.2600	7.4800	7.7000	7.9200	8.1400	8.3600	8.5800	30
40	8.8000	9.0200	9.2400	9.4600	9.6800	9.9000	10.1200	10.3400	10.5600	10.7800	40
50	11.0000	11.2200	11.4400	11.6600	11.8800	12.1000	12.3200	12.5400	12.7600	12.9800	50
60	13.2000	13.4200	13.6400	13.8600	14.0800	14.3000	14.5200	14.7400	14.9600	15.1800	60
70	15.4000	15.6200	15.8400	16.0600	16.2800	16.5000	16.7200	16.9400	17.1600	17.3800	70
80	17.6000	17.8200	18.0400	18.2600	18.4800	18.7000	18.9200	19.1400	19.3600	19.5800	80
90	19.8000	20.0200	20.2400	20.4600	20.6800	20.9000	21.1200	21.3400	21.5600	21.7800	90
100	22.0000	22.2200	22.4400	22.6600	22.8800	23.1000	23.3200	23.5400	23.7600	23.9800	100

**Weight**

**Pounds to kilograms**

lbs.	0	1	2	3	4	5	6	7	8	9	lbs.
	kg	kg	kg	kg	kg	kg	kg	kg	kg	kg	
----		0.454	0.907	1.361	1.814	2.268	2.722	3.175	3.629	4.082	----
10	4.536	4.989	5.443	5.897	6.350	6.804	7.257	7.711	8.165	8.618	10
20	9.072	9.525	9.979	10.433	10.886	11.340	11.793	12.247	12.701	13.154	20
30	13.608	14.061	14.515	14.968	15.422	15.876	16.329	16.783	17.236	17.690	30
40	18.144	18.597	19.051	19.504	19.958	20.412	20.865	21.319	21.772	22.226	40
50	22.680	23.133	23.587	24.040	24.494	24.947	25.401	25.855	26.308	26.762	50
60	27.215	27.669	28.123	28.576	29.030	29.483	29.937	30.391	30.844	31.298	60
70	31.751	32.205	32.658	33.112	33.566	34.019	34.473	34.926	35.380	35.834	70
80	36.287	36.741	37.194	37.648	38.102	38.555	39.009	39.462	39.916	40.370	80
90	40.823	41.277	41.730	42.184	42.637	43.091	43.545	43.998	44.452	44.905	90
100	45.359	45.813	46.266	46.720	47.173	47.627	48.081	48.534	48.988	49.441	100



INTRODUCTION

**Kilograms to pounds**

kg	0	1	2	3	4	5	6	7	8	9	kg
	lbs.	lbs.	lbs.	lbs.	lbs.	lbs.	lbs.	lbs.	lbs.	lbs.	
----		2.205	4.409	6.614	8.819	11.023	13.228	15.432	17.637	19.842	----
10	22.046	24.251	26.456	28.660	30.865	33.069	35.274	37.479	39.683	41.888	10
20	44.093	46.297	48.502	50.707	52.911	55.116	57.320	59.525	61.730	63.934	20
30	66.139	68.344	70.548	72.753	74.958	77.162	79.367	81.571	83.776	85.981	30
40	88.185	90.39	92.595	94.799	97.004	99.209	101.413	103.618	105.822	108.027	40
50	110.232	112.436	114.641	116.846	119.050	121.255	123.460	125.664	127.869	130.073	50
60	132.278	134.483	136.687	138.892	141.097	143.301	145.506	147.710	149.915	152.120	60
70	154.324	156.529	158.734	160.938	163.143	165.348	167.552	169.757	171.961	174.166	70
80	176.371	178.575	180.780	182.985	185.189	187.394	189.599	191.803	194.008	196.212	80
90	198.417	200.622	202.826	205.031	207.236	209.440	211.645	213.850	216.054	218.259	90
100	220.463	222.668	224.873	227.077	229.282	231.487	233.691	235.896	238.100	240.305	100

**Weight kilograms to newtons**

kgf	0	1	2	3	4	5	6	7	8	9	kg
	N	N	N	N	N	N	N	N	N	N	
----		9.81	19.61	29.42	39.23	49.03	58.84	68.65	78.45	88.26	----
10	98.07	107.87	117.68	127.49	137.29	147.10	156.91	166.71	176.52	186.33	10
20	196.13	205.94	215.75	225.55	235.36	245.17	254.97	264.78	274.59	284.39	20
30	294.20	304.01	313.81	323.62	333.43	343.23	353.04	362.85	372.65	382.46	30
40	392.27	402.07	411.88	421.69	431.49	441.30	451.11	460.91	470.72	480.53	40
50	490.33	500.14	509.95	519.75	529.56	539.37	549.17	558.98	568.79	578.59	50
60	588.40	598.21	608.01	617.82	627.63	637.43	647.24	657.05	666.85	676.66	60
70	686.47	696.27	706.08	715.89	725.69	735.50	745.31	755.11	764.92	774.73	70
80	784.53	794.34	804.15	813.95	823.76	833.57	843.37	853.18	862.99	872.79	80
90	882.60	892.41	902.21	912.02	921.83	931.63	941.44	951.25	961.05	970.86	90
100	980.67	990.47	1000.28	1010.08	1019.89	1029.70	1039.5	1049.31	1059.12	1068.92	100

**Newtons to weight kilograms**

N	0	1	2	3	4	5	6	7	8	9	N
	kgf	kgf	kgf	kgf	kgf	kgf	kgf	kgf	kgf	kgf	
----		0.1020	0.2039	0.3059	0.4079	0.5099	0.6118	0.7138	0.8158	0.9177	----
10	1.0197	1.1217	1.2237	1.3256	1.4276	1.5296	1.6315	1.7335	1.8355	1.9375	10
20	2.0394	2.1414	2.2434	2.3453	2.4473	2.5493	2.6513	2.7532	2.8552	2.9572	20
30	3.0591	3.1611	3.2631	3.3651	3.4670	3.5690	3.6710	3.7729	3.8749	3.9769	30
40	4.0789	4.1808	4.2828	4.3848	4.4868	4.5887	4.6907	4.7927	4.8946	4.9966	40
50	5.0986	5.2006	5.3025	5.4045	5.5065	5.6084	5.7104	5.8124	5.9144	6.0163	50
60	6.1183	6.2203	6.3222	6.4242	6.5262	6.6282	6.7301	6.8321	6.9341	7.0360	60
70	7.1380	7.2400	7.3420	7.4439	7.5459	7.6479	7.7498	7.8518	7.9538	8.0558	70
80	8.1577	8.2597	8.3617	8.4636	8.5656	8.6676	8.7696	8.8715	8.9735	9.0755	80
90	9.1774	9.2794	9.3814	9.4834	9.5853	9.6873	9.7893	9.8912	9.9932	10.0952	90
100	10.1972	10.2991	10.4011	10.5031	10.6050	10.7070	10.8090	10.9110	11.0129	11.1149	100

INTRODUCTION

**Pressure**

**Weight pounds/square inch to weight kilograms/square centimeter**

lbf/in <sup>2</sup>	0	1	2	3	4	5	6	7	8	9	lbf/in <sup>2</sup>
(psi)	kgf/cm <sup>2</sup>	kgf/cm <sup>2</sup>	kgf/cm <sup>2</sup>	kgf/cm <sup>2</sup>	kgf/cm <sup>2</sup>	kgf/cm <sup>2</sup>	kgf/cm <sup>2</sup>	kgf/cm <sup>2</sup>	kgf/cm <sup>2</sup>	kgf/cm <sup>2</sup>	(psi)
----		0.0703	0.1406	0.2109	0.2812	0.3515	0.4218	0.4921	0.5624	0.6327	----
10	0.7030	0.7733	0.8436	0.9139	0.9842	1.0545	1.1248	1.1951	1.2654	1.3357	10
20	1.4060	1.4763	1.5466	1.6169	1.6872	1.7575	1.8278	1.8981	1.9684	2.0387	20
30	2.1090	2.1793	2.2496	2.3199	2.3902	2.4605	2.5308	2.6011	2.6714	2.7417	30
40	2.8120	2.8823	2.9526	3.0229	3.0932	3.1635	3.2338	3.3041	3.3744	3.4447	40
50	3.5150	3.5853	3.6556	3.7259	3.7962	3.8665	3.9368	4.0071	4.0774	4.1477	50
60	4.2180	4.2883	4.3586	4.4289	4.4992	4.5695	4.6397	4.7100	4.7803	4.8506	60
70	4.9209	4.9912	5.0615	5.1318	5.2021	5.2724	5.3427	5.4130	5.4833	5.5536	70
80	5.6239	5.6942	5.7645	5.8348	5.9051	5.9754	6.0457	6.1160	6.1863	6.2566	80
90	6.3269	6.3972	6.4675	6.5378	6.6081	6.6784	6.7487	6.8190	6.8893	6.9596	90
100	7.0299	7.1002	7.1705	7.2408	7.3111	7.3814	7.4517	7.5220	7.5923	7.6626	100

**Weight kilograms/square centimeter to weight pounds/square inch**

kgf/cm <sup>2</sup>	0	1	2	3	4	5	6	7	8	9	kgf/cm <sup>2</sup>
	lbf/in <sup>2</sup> (psi)	lbf/in <sup>2</sup> (psi)	lbf/in <sup>2</sup> (psi)	lbf/in <sup>2</sup> (psi)	lbf/in <sup>2</sup> (psi)	lbf/in <sup>2</sup> (psi)	lbf/in <sup>2</sup> (psi)	lbf/in <sup>2</sup> (psi)	lbf/in <sup>2</sup> (psi)	lbf/in <sup>2</sup> (psi)	
----		14.22	28.45	42.67	56.90	71.12	85.35	99.57	113.80	128.02	----
10	142.25	156.47	170.70	184.92	199.15	213.37	227.60	241.82	256.05	270.27	10
20	284.50	298.72	312.95	327.17	341.40	355.62	369.85	384.07	398.30	412.52	20
30	426.75	440.97	455.20	469.42	483.65	497.87	512.10	526.32	540.55	554.77	30
40	569.00	583.22	597.45	611.67	625.90	640.12	654.35	668.57	682.80	697.02	40
50	711.25	725.47	739.70	753.92	768.14	782.37	796.59	810.82	825.04	839.27	50
60	853.49	867.72	881.94	896.17	910.39	924.62	938.84	953.07	967.29	981.52	60
70	995.74	1009.97	1024.19	1038.42	1052.64	1066.87	1081.09	1095.32	1109.54	1123.77	70
80	1137.99	1152.22	1166.44	1180.67	1194.89	1209.12	1223.34	1237.57	1251.79	1266.02	80
90	1280.24	1294.47	1308.69	1322.92	1337.14	1351.37	1365.59	1379.82	1394.04	1408.27	90
100	1422.49	1436.72	1450.94	1465.17	1479.39	1493.62	1507.84	1522.06	1536.29	1550.51	100

**Weight kilograms/square centimeter to kilopascals**

kgf/cm <sup>2</sup>	0	1	2	3	4	5	6	7	8	9	kgf/cm <sup>2</sup>
	kpa	kpa	kpa	kpa	kpa	kpa	kpa	kpa	kpa	kpa	
----		98.1	196.1	294.2	392.3	490.3	588.4	686.5	784.5	882.6	----
10	980.7	1078.7	1176.8	1274.9	1372.9	1471.0	1569.1	1667.1	1765.2	1863.3	10
20	1961.3	2059.4	2157.5	2255.5	2353.6	2451.7	2549.7	2647.8	2745.9	2843.9	20
30	2942.0	3040.1	3138.1	3236.2	3334.3	3432.3	3530.4	3628.5	3726.5	3824.6	30
40	3922.7	4020.7	4118.8	4216.9	4314.9	4413.0	4511.1	4609.1	4707.2	4805.3	40
50	4903.3	5001.4	5099.5	5197.5	5295.6	5393.7	5491.7	5589.8	5687.9	5785.9	50
60	5884.0	5982.1	6080.1	6178.2	6276.3	6374.3	6472.4	6570.5	6668.5	6766.6	60
70	6864.7	6962.7	7060.8	7158.9	7256.9	7355.0	7453.1	7551.1	7649.2	7747.3	70
80	7845.3	7943.4	8041.5	8139.5	8237.6	8335.7	8433.7	8531.8	8629.9	8727.9	80
90	8826.0	8924.1	9022.1	9120.2	9218.3	9316.3	9414.4	9512.5	9610.5	9708.6	90
100	9806.7	9904.7	10002.8	10100.8	10198.9	10297	10395.0	10493.1	10591.2	10689.2	100

INTRODUCTION

**Kilopascals to weight kilograms/square centimeter**

kpa	0	100	200	300	400	500	600	700	800	900	kpa
	kgf/cm <sup>2</sup>	kgf/cm <sup>2</sup>	kgf/cm <sup>2</sup>	kgf/cm <sup>2</sup>	kgf/cm <sup>2</sup>	kgf/cm <sup>2</sup>	kgf/cm <sup>2</sup>	kgf/cm <sup>2</sup>	kgf/cm <sup>2</sup>	kgf/cm <sup>2</sup>	
----		1.020	2.039	3.059	4.079	5.099	6.118	7.138	8.158	9.177	----
1000	10.197	11.217	12.237	13.256	14.276	15.296	16.315	17.335	18.355	19.375	1000
2000	20.394	21.414	22.434	23.453	24.473	25.493	26.513	27.532	28.552	29.572	2000
3000	30.591	31.611	32.631	33.651	34.670	35.690	36.710	37.729	38.749	39.769	3000
4000	40.789	41.808	42.828	43.848	44.868	45.887	46.907	47.927	48.946	49.966	4000
5000	50.986	52.006	53.025	54.045	55.065	56.084	57.104	58.124	59.144	60.163	5000
6000	61.183	62.203	63.222	64.242	65.262	66.282	67.301	68.321	69.341	70.360	6000
7000	71.380	72.400	73.420	74.439	75.459	76.479	77.498	78.518	79.538	80.558	7000
8000	81.577	82.597	83.617	84.636	85.656	86.676	87.696	88.715	89.735	90.755	8000
9000	91.774	92.794	93.814	94.834	95.853	96.873	97.893	98.912	99.932	100.952	9000
10000	101.972	102.991	104.011	105.031	106.050	107.070	108.090	109.110	110.129	111.149	10000

**Torque**

**Feet weight pounds to weight kilogram meters**

lbf.ft	0	1	2	3	4	5	6	7	8	9	lbf.ft
	kgf·m	kgf·m	kgf·m	kgf·m	kgf·m	kgf·m	kgf·m	kgf·m	kgf·m	kgf·m	
----		0.138	0.277	0.415	0.553	0.692	0.830	0.969	1.107	1.245	----
10	1.384	1.522	1.660	1.799	1.937	2.075	2.214	2.352	2.490	2.629	10
20	2.767	2.906	3.044	3.182	3.321	3.459	3.597	3.736	3.874	4.012	20
30	4.151	4.289	4.428	4.566	4.704	4.843	4.981	5.119	5.258	5.396	30
40	5.534	5.673	5.811	5.949	6.088	6.226	6.365	6.503	6.641	6.780	40
50	6.918	7.056	7.195	7.333	7.471	7.610	7.748	7.887	8.025	8.163	50
60	8.302	8.440	8.578	8.717	8.855	8.993	9.132	9.270	9.409	9.547	60
70	9.685	9.824	9.962	10.100	10.239	10.377	10.515	10.654	10.792	10.930	70
80	11.069	11.207	11.346	11.484	11.622	11.761	11.899	12.037	12.176	12.314	80
90	12.452	12.591	12.729	12.868	13.006	13.144	13.283	13.421	13.559	13.698	90
100	13.836	13.974	14.113	14.251	14.389	14.528	14.666	14.805	14.943	15.081	100

**Weight kilogram meters to feet weight pounds**

kgf·m	0	1	2	3	4	5	6	7	8	9	kgf·m
	lbf.ft	lbf.ft	lbf.ft	lbf.ft	lbf.ft	lbf.ft	lbf.ft	lbf.ft	lbf.ft	lbf.ft	
----		7.228	14.455	21.683	28.910	36.138	43.365	50.593	57.820	65.048	----
10	72.275	79.503	86.730	93.958	101.185	108.413	115.640	122.868	130.095	137.323	10
20	144.550	151.778	159.005	166.233	173.460	180.688	187.915	195.143	202.370	209.598	20
30	216.825	224.053	231.280	238.508	245.735	252.963	260.190	267.418	274.645	281.873	30
40	289.100	296.328	303.555	310.783	318.010	325.238	332.465	339.693	346.920	354.148	40
50	361.375	368.603	375.830	383.058	390.285	397.513	404.740	411.968	419.195	426.423	50
60	433.650	440.878	448.105	455.333	462.560	469.788	477.015	484.243	491.470	498.698	60
70	505.925	513.153	520.380	527.608	534.835	542.063	549.290	556.518	563.745	570.973	70
80	578.200	585.428	592.655	599.883	607.110	614.338	621.565	628.793	636.020	643.248	80
90	650.475	657.703	664.930	672.158	679.385	686.613	693.840	701.068	708.295	715.523	90
100	722.750	729.978	737.205	744.433	751.660	758.888	766.115	773.343	780.570	787.798	100

INTRODUCTION

**Weight kilogram meters to Newton meters**

kgf·m	0	1	2	3	4	5	6	7	8	9	kgf·m
	N·m	N·m	N·m	N·m	N·m	N·m	N·m	N·m	N·m	N·m	
----		9.81	19.61	29.42	39.23	49.03	58.84	68.65	78.45	88.26	----
10	98.07	107.87	117.68	127.49	137.29	147.10	156.91	166.71	176.52	186.33	10
20	196.13	205.94	215.75	225.55	235.36	245.17	254.97	264.78	274.59	284.39	20
30	294.20	304.01	313.81	323.62	333.43	343.23	353.04	362.85	372.65	382.46	30
40	392.27	402.07	411.88	421.69	431.49	441.30	451.11	460.91	470.72	480.53	40
50	490.33	500.14	509.95	519.75	529.56	539.37	549.17	558.98	568.79	578.59	50
60	588.40	598.21	608.01	617.82	627.63	637.43	647.24	657.05	666.85	676.66	60
70	686.47	696.27	706.08	715.89	725.69	735.50	745.31	755.11	764.92	774.73	70
80	784.53	794.34	804.15	813.95	823.76	833.57	843.37	853.18	862.99	872.79	80
90	882.60	892.41	902.21	912.02	921.83	931.63	941.44	951.25	961.05	970.86	90
100	980.67	990.47	1000.28	1010.08	1019.89	1029.70	1039.5	1049.31	1059.12	1068.92	100

**Newton meters to weight kilogram meters**

N·m	0	10	20	30	40	50	60	70	80	90	N·m
	kgf·m	kgf·m	kgf·m	kgf·m	kgf·m	kgf·m	kgf·m	kgf·m	kgf·m	kgf·m	
----		1.020	2.039	3.059	4.079	5.099	6.118	7.138	8.158	9.177	----
100	10.197	11.217	12.237	13.256	14.276	15.296	16.315	17.335	18.355	19.375	10
200	20.394	21.414	22.434	23.453	24.473	25.493	26.513	27.532	28.552	29.572	20
300	30.591	31.611	32.631	33.651	34.670	35.690	36.710	37.729	38.749	39.769	30
400	40.789	41.808	42.828	43.848	44.868	45.887	46.907	47.927	48.946	49.966	40
500	50.986	52.006	53.025	54.045	55.065	56.084	57.104	58.124	59.144	60.163	50
600	61.183	62.203	63.222	64.242	65.262	66.282	67.301	68.321	69.341	70.360	60
700	71.380	72.400	73.420	74.439	75.459	76.479	77.498	78.518	79.538	80.558	70
800	81.577	82.597	83.617	84.636	85.656	86.676	87.696	88.715	89.735	90.755	80
900	91.774	92.794	93.814	94.834	95.853	96.873	97.893	98.912	99.932	100.952	90
1000	101.972	102.991	104.011	105.031	106.050	107.070	108.090	109.110	110.129	111.149	100

---

**Temperature**
**Fahrenheit to centigrade**

°F	°C	°F	°C	°F	°C	°F	°C	°F	°C	°F	°C	°F	°C	°F	°C
-60	-51.1	2	-18.9	56	13.3	114	45.6	172	77.8	230	110	288	142.2	346	174.4
-58	-50	0	-17.8	58	14.4	116	46.7	174	78.9	232	111.1	290	143.3	348	175.6
-56	-48.9	2	-16.7	60	15.6	118	47.8	176	80.0	234	112.2	292	144.4	350	176.7
-54	-47.8	4	-15.6	62	16.7	120	48.9	178	81.1	236	113.3	294	145.6	352	177.8
-52	-46.7	6	-14.4	64	17.8	122	50.0	180	82.2	238	114.4	296	146.7	354	178.9
-50	-45.6	8	-13.3	66	18.9	124	51.1	182	83.3	240	115.6	298	147.8	356	180
-48	-44.4	10	-12.2	68	20	126	52.2	184	84.4	242	116.7	300	148.9	358	181.1
-46	-43.3	12	-11.1	70	21.1	128	53.3	186	85.6	244	117.8	302	150	360	182.2
-44	-42.2	14	-10	72	22.2	130	54.4	188	86.7	246	118.9	304	151.1	362	183.3
-42	-41.1	16	-8.9	74	23.3	132	55.6	190	87.8	248	120	306	152.2	364	184.4
-40	-40.0	18	-7.8	76	24.4	134	56.7	192	88.9	250	121.1	308	153.3	366	185.6
-38	-38.9	20	-6.7	78	25.6	136	57.8	194	90.0	252	122.2	310	154.4	368	186.7
-36	-37.8	22	-5.6	80	26.7	138	58.9	196	91.1	254	123.3	312	155.6	370	187.8
-34	-36.7	24	-4.4	82	27.8	140	60	198	92.2	256	124.4	314	156.7	372	188.9
-32	-35.6	26	-3.3	84	28.9	142	61.1	200	93.3	258	125.6	316	157.8	374	190.0
-30	-34.4	28	-2.2	86	30.0	144	62.2	202	94.4	260	126.7	318	158.9	376	191.1
-28	-33.3	30	-1.1	88	31.1	146	63.3	204	95.6	262	127.8	320	160	378	192.2
-26	-32.2	32	0.0	90	32.2	148	64.4	206	96.7	264	128.9	322	161.1	380	193.3
-24	-31.1	34	1.1	92	33.3	150	65.6	208	97.8	266	130.0	324	162.2	382	194.4
-22	-30.0	36	2.2	94	34.4	152	66.7	210	98.9	268	131.1	326	163.3	384	195.6
-20	-28.9	38	3.3	96	35.6	154	67.8	212	100.0	270	132.2	328	164.4	386	196.7
-18	-27.8	40	4.4	98	36.7	156	68.9	214	101.1	272	133.3	330	165.6	388	197.8
-16	-26.7	42	5.6	100	37.8	158	70.0	216	102.2	274	134.4	332	166.7	390	198.9
-14	-25.6	44	6.7	102	38.9	160	71.1	218	103.3	276	135.6	334	167.8	392	200
-12	-24.4	46	7.8	104	40.0	162	72.2	220	104.4	278	136.7	336	168.9	400	204.4
-10	-23.3	48	8.9	106	41.1	164	73.3	222	105.6	280	137.8	338	170.0	410	210.0
-8	-22.2	50	10.0	108	42.2	166	74.4	224	106.7	282	138.9	340	171.1	420	215.6
-6	-21.1	52	11.1	110	43.3	168	75.6	226	107.8	284	140.0	342	172.2	430	221.1
-4	-20.0	54	12.2	112	44.4	170	76.7	228	108.9	286	141.1	344	173.3	440	226.7

INTRODUCTION

Centigrade to fahrenheit

°C	°F	°C	°F	°C	°F	°C	°F	°C	°F	°C	°F	°C	°F	°C	°F
-50	-58.0	-18	-0.4	14	57.2	46	114.8	78	172.4	110	230.0	142	287.6	174	345.2
-49	-56.2	-17	1.4	15	59.0	47	116.6	79	174.2	111	231.8	143	289.4	175	347.0
-48	-54.4	-16	3.2	16	60.8	48	118.4	80	176.0	112	233.6	144	291.2	176	348.8
-47	-52.6	-15	5.0	17	62.6	49	120.2	81	177.8	113	235.4	145	293.0	177	350.6
-46	-50.8	-14	6.8	18	64.4	50	122.0	82	179.6	114	237.2	146	294.8	178	352.4
-45	-49.0	-13	8.6	19	66.2	51	123.8	83	181.4	115	239.0	147	296.6	179	354.2
-44	-47.2	-12	10.4	20	68.0	52	125.6	84	183.2	116	240.8	148	298.4	180	356.0
-43	-45.4	-11	12.2	21	69.8	53	127.4	85	185.0	117	242.6	149	300.2	181	357.8
-42	-43.6	-10	14.0	22	71.6	54	129.2	86	186.8	118	244.4	150	302.0	182	359.6
-41	-41.8	-9	15.8	23	73.4	55	131.0	87	188.6	119	246.2	151	303.8	183	361.4
-40	-40.0	-8	17.6	24	75.2	56	132.8	88	190.4	120	248.0	152	305.6	184	363.2
-39	-38.2	-7	19.4	25	77.0	57	134.6	89	192.2	121	249.8	153	307.4	185	365.0
-38	-36.4	-6	21.2	26	78.8	58	136.4	90	194.0	122	251.6	154	309.2	186	366.8
-37	-34.6	-5	23.0	27	80.6	59	138.2	91	195.8	123	253.4	155	311.0	187	368.6
-36	-32.8	-4	24.8	28	82.4	60	140.0	92	197.6	124	255.2	156	312.8	188	370.4
-35	-31.0	-3	26.6	29	84.2	61	141.8	93	199.4	125	257.0	157	314.6	189	372.2
-34	-29.2	-2	28.4	30	86.0	62	143.6	94	201.2	126	258.8	158	316.4	190	374.0
-33	-27.4	-1	30.2	31	87.8	63	145.4	95	203.0	127	260.6	159	318.2	191	375.8
-32	-25.6	0	32.0	32	89.6	64	147.2	96	204.8	128	262.4	160	320.0	192	377.6
-31	-23.8	1	33.8	33	91.4	65	149.0	97	206.6	129	264.2	161	321.8	193	379.4
-30	-22.0	2	35.6	34	93.2	66	150.8	98	208.4	130	266.0	162	323.6	194	381.2
-29	-20.2	3	37.4	35	95.0	67	152.6	99	210.2	131	267.8	163	325.4	195	383.0
-28	-18.4	4	39.2	36	96.8	68	154.4	100	212.0	132	269.6	164	327.2	196	384.8
-27	-16.6	5	41.0	37	98.6	69	156.2	101	213.8	133	271.4	165	329.0	197	386.6
-26	-14.8	6	42.8	38	100.4	70	158.0	102	215.6	134	273.2	166	330.8	198	388.4
-25	-13.0	7	44.6	39	102.2	71	159.8	103	217.4	135	275.0	167	332.6	199	390.2
-24	-11.2	8	46.4	40	104.0	72	161.6	104	219.2	136	276.8	168	334.4	200	392.0
-23	-9.4	9	48.2	41	105.8	73	163.4	105	221.0	137	278.6	169	336.2	210	410.0
-22	-8	10	50.0	42	107.6	74	165.2	106	222.8	138	280.4	170	338.0	220	428.0
-21	-6	11	51.8	43	109.4	75	167.0	107	224.6	139	282.2	171	339.8	230	446.0
-20	-4	12	53.6	44	111.2	76	168.8	108	226.4	140	284.0	172	341.6	240	464.0
-19	-2	13	55.4	45	113.0	77	170.6	109	228.2	141	285.8	173	343.4	250	482.0

## Hydraulic contamination

Contamination in the hydraulic system is a major cause of the malfunction of hydraulic components. Contamination is any foreign material in the hydraulic oil.

Contamination can enter the hydraulic system in several ways:

- When you drain the oil or disconnect any line
- When you disassemble a component
- From normal wear of the hydraulic components
- From damaged seals or worn seals
- From a damaged component in the hydraulic system

All hydraulic systems operate with some contamination. The design of the components in this hydraulic system permits efficient operation with a small amount of contamination. An increase in this amount of contamination can cause problems in the hydraulic system.

The following list includes some of these problems:

- Cylinder rod seals that leak
- Control valve spools that do not return to neutral
- Movement of control valve spools is difficult
- Hydraulic oil that becomes too hot
- Pump gears, housing, and other parts that wear rapidly
- Relief valves or check valves held open by dirt
- Quick failure of components that have been repaired
- Slow cycle times are slow. The machine does not have enough power.

If your machine has any of these problems, check the hydraulic oil for contamination.

There are two types of contamination: microscopic and visible.

Microscopic contamination occurs when very fine particles of foreign material are suspended in the hydraulic oil. These particles are too small to see or feel. Microscopic contamination can be found by identification of the following problems or by testing in a laboratory.

Examples of problems caused by microscopic contamination:

- Cylinder rod seals that leak
- Control valve spools that do not return to neutral
- The hydraulic system has a high operating temperature

Visible contamination is foreign material that can be found by sight, touch, or odor. Visible contamination can cause a sudden failure of components.

Examples of problems caused by visible contamination:

- Particles of metal or dirt in the oil
- Air in the oil
- Dark or thick oil
- Oil with an odor of burned oil
- Water in the oil

If you find contamination, use a portable filter to clean the hydraulic system.

---

## General specification

### Biodiesel usage in CASE CONSTRUCTION products

#### Introduction to Fatty Acid Methyl Ester (FAME) biodiesel

FAME biodiesel, called biodiesel fuel in the following section, consists of a family of fuels derived from vegetable oils treated with methyl esters.

There are two main biodiesel fuel types: Rapeseed Methyl Ester (RME) and Soybean Methyl Ester (SME). RME is a blend of rapeseed and sunflower methyl ester, and is the preferred crop in Europe. SME is the preferred crop in the United States.

Biodiesel fuel is a renewable alternative fuel source. Its use and development is promoted worldwide, especially in Europe and in the United States.

**NOTICE:** *Your emissions control system is compatible with up to 5% biodiesel fuel ( B5 ). Be aware that the use of biodiesel fuel that does not comply with the standards mentioned in this section could lead to severe damage to the engine, fuel system or after treatment system of your machine. The use of non-approved fuels may void CASE CONSTRUCTION Warranty coverage.*

Biodiesel fuel can be used to run diesel engines as pure biodiesel fuel or when blended with standard diesel fuel:

- B5 : indicates the blend of **5%** biodiesel and **95%** diesel fuels.

**NOTICE:** *Never use biodiesel blends higher than B5.*

Biodiesel fuel has several positive features in comparison with diesel fuel:

- Biodiesel fuel adds lubricity to the fuel, which is beneficial in many circumstances, particularly as sulfur and aromatics are removed from the fuel.
- Biodiesel has a greater cetane number and burns cleaner.
- Biodiesel produces less particulate matter and reduces smoke emissions.
- Biodiesel is fully biodegradable and non-toxic.

#### Diesel and biodiesel fuel specifications

TIER 4 FINAL diesel fuel specifications are covered by the following:

- **ASTM D975**, Standard Specification for Diesel Fuel Oils. (15 ppm sulfur maximum.)

Biodiesel blends are covered by:

- United States Diesel Fuel Specification **ASTM D975** allows up to **5%** biodiesel since 2009. United States fuel suppliers are allowed to use up to **5%** biodiesel fuel (B5) to supply the network.
- United States Biodiesel Fuel Specification **ASTM D7467** provides specifications for biodiesel blends from B6 to B20.

Pure biodiesel (B100) specification is covered by the following requirements:

- **ASTM D6751** - Standard specification for biodiesel fuel blend stock (B100) for middle distillate fuels.

Before raw oil can be converted into usable biodiesel fuel, it must undergo transesterification to remove glycerides. During the transesterification process, the oil reacts with an alcohol to separate the glycerine from the fat or vegetable oil. This process leaves behind two products: methyl ester (the chemical name for biodiesel) and glycerine (a byproduct usually sold for use in soaps or other products).

**NOTICE:** *Biodiesel fuels approved for use in the CASE CONSTRUCTION equipment must be transesterified and comply with the North America Standard **ASTM D6751**.*

**NOTICE:** *Cold Pressed Biodiesel, Cold Pressed Oil, Straight Vegetable Oil (SVO), or more generally unrefined vegetable oils used as motor fuel, are fuels that are normally made from Rapeseed oil or similar high oil content crops. These kinds of fuel are not transesterified, so they do not fulfil the **ASTM D6751** requirements. There is no recognized quality standard available for these types of fuel. Therefore the use of Cold Pressed Biodiesel, Cold Pressed*



*Oil, Straight Vegetable Oil (SVO), or more generally unrefined vegetable oils used as motor fuel are NOT APPROVED at any blend in any CASE CONSTRUCTION product.*

**NOTICE:** Any engine and fuel injection equipment fitted to a CASE CONSTRUCTION vehicle found to have run with any blend of NON-APPROVED fuel (fuel not fulfilling the specification described in the requirement **ASTM D6751**) will no longer be covered for Warranty by CASE CONSTRUCTION.

### **Biodiesel fuel usage conditions**

You must stringently follow the biodiesel fuel usage conditions. Incorrect application of the biodiesel fuel usage conditions could lead to severe damage to the engine, fuel injection equipment and aftertreatment system.

The main concerns related to operation with biodiesel fuels are:

- Filters and injector blockage caused by poor fuel quality.
- Wear and corrosion of internal components due to water content, which affects lubricity.
- Deterioration of some rubber sealing compounds in the fuel system.
- Biodiesel oxidation, which can lead to the formation of deposits that can harm the fuel injection system.

**NOTICE:** Any problem in the engine fuel injection equipment associated with non-compliance to the following conditions for biodiesel fuel handling and maintenance will not be covered for Warranty by CASE CONSTRUCTION.

Purchase biodiesel fuel from a trusted supplier who understands the product and maintains acceptable fuel quality. It is highly recommended that you use biodiesel from BQ 9000 accredited suppliers to maintain the quality and consistency of the fuel. The BQ 9000 Quality Management Program is accredited by the National Biodiesel Board for producers and marketers of biodiesel fuel. See the National Biodiesel Board website at [www.biodiesel.org](http://www.biodiesel.org) for more information.

### **Storage**

The machine should not be stored for long periods without changing the diesel fuel in the fuel system.

**NOTICE:** Biodiesel is highly hygroscopic and tends to collect water more than diesel fuel. This increases the risk of algae and bacteria growth which can cause severe damage to the fuel injection system. Keep the machine fuel tanks and on-site storage tanks as full as possible to limit the amount of air and water vapors inside the tank. Drain water from the tanks at least once a week.

If the machine should be stored for long periods, make sure to replace the diesel fuel every three months at most.

## Fluids and lubricants

By using appropriate fluids and lubricants the excavator can operate in ambient temperatures ranging from **-15 °C (-4 °F)** to **45 °C (113 °F)**.

**NOTICE:** when operating the machine in ambient temperatures outside the above mentioned range, consult your **CASE CONSTRUCTION** dealer for specific machine provision and for specific fluids and lubricants to be used.

	Quantity		CASE CON- STRUCTION specification	Reference specification
Fuel tank	<b>40 L (10.6 US gal)</b>	—	—	<b>ASTM D975 EN 590</b>
Engine oil	<b>6.7 L (1.8 US gal)</b>	<b>CASE AKCELA NO. 1™ ENGINE OIL SAE 15W-40</b>	MS 1121	<b>SAE 15W-40 ACEA E7/E5 API CI-4</b>
Travel reduction unit	<b>0.5 L (0.13 US gal) x2</b>	<b>CASE AKCELA GEAR 135 H EP 80W-90</b>	<b>MAT3511</b>	<b>SAE 80W90 API GL-5</b>
Engine coolant	<b>5 L (1.3 US gal)</b>	<b>CASE AKCELA ACTIFULL™ OT EXTENDED LIFE COOLANT CONCENTRATE</b>	<b>MAT3624</b> Grade OAT-EG1	<b>ASTM D6210 TYPE I-FF</b>
		<b>CASE AKCELA ACTIFULL™ OT EXTENDED LIFE COOLANT 50/50 PREMIXED</b>	<b>MAT3624</b> Grade OAT-EG2	<b>ASTM D6210 TYPE III-FF</b>
Hydraulic oil tank (*)	<b>37 L (9.8 US gal)</b>	<b>CASE AKCELA HYDRAULIC LL 46</b>	—	<b>ISO 11158 L-HV46</b>
Grease (Attachment)	—	<b>CASE AKCELA MOLY GREASE</b>	<b>MAT3550</b>	<b>NLGI 2</b>
Grease (Swing bearing)	—	<b>CASE AKCELA 251H EP MULTI- PURPOSE GREASE</b>	<b>MAT3550</b> Grade A	<b>NLGI 2</b>

(\*) The total capacity of the hydraulic system is **60 L (15.9 US gal)**.

## Engine coolant

CASE CONSTRUCTION requires the use of a fully formulated Organic Acid Technology (OAT) based coolant. **CASE AKCELA ACTIFULL™ OT EXTENDED LIFE COOLANT** is the reference genuine product.

**NOTICE:** use of different coolant brands is not recommended.

**NOTICE:** never add Supplemental Coolant Additives (SCA) when using **CASE AKCELA ACTIFULL™ OT EXTENDED LIFE COOLANT**.

**NOTICE:** never mix **CASE AKCELA ACTIFULL™ OT EXTENDED LIFE COOLANT** coolant with conventional coolant. Mixing OAT based coolant with conventional coolant will reduce the effectiveness of OAT coolant.

**NOTICE:** if only conventional coolant is available, a complete changeover of the fluid into the cooling system shall be carried out.

the engine cooling system shall always be refilled with coolant solution made by mixture of antifreeze and distilled (deionized) water.

**NOTICE:** never refill the cooling system with only antifreeze. Never refill the cooling system with only water.

Using **CASE AKCELA ACTIFULL™ OT EXTENDED LIFE COOLANT**, a 50/50 mixture of antifreeze and distilled (deionized) water grants proper performance of the engine cooling system in the above mentioned operating temperature range of the machine.

**CASE AKCELA ACTIFULL™ OT EXTENDED LIFE COOLANT** is available as:

- 50/50 PREMIXED coolant solution ready for usage.
- CONCENTRATE antifreeze to be mixed 50/50 with distilled (deionized) water.

**NOTICE:** if operating in extreme winter climate, a coolant solution made by 60/40 antifreeze/distilled (deionized) water mixture shall be used in order to grant proper performance of the engine cooling system.

**NOTICE:** never use coolant solution with more than **60%** of antifreeze. This affects the cooling capacity of the mixture.

When the coolant solution is prepared starting from the CONCENTRATE product, the antifreeze concentration in the mixture of antifreeze and distilled (deionized) water can be determined with a refractometer designed to measure ethylene glycol content.

**If distilled (deionized) water is not available, use water for dilution with the following properties:**

Property	Maximum limit
Total Solids	<b>340 ppm</b>
Total Hardness	<b>340 ppm</b>
Chloride (Cl)	<b>340 ppm</b>
Sulfate (SO <sub>4</sub> )	<b>100 ppm</b>
Acidity pH	5.5 to 9.0

**NOTICE:** never use hard water, sea water and softened sea water that has been conditioned with salt. The minerals and salts present in potable water can cause corrosion and deposits resulting in shortened engine life.

## Fuel

For Europe only: use only Ultra-Low Sulphur Diesel (S10) that meets **EN 590** specifications.

For North America only: use only No. 2-D Ultra-Low Sulphur Diesel ( S15) that meets **ASTM D975** specifications.

Using other types of fuel may lead to stalled engine output or deterioration in fuel economy.

**NOTICE:** *the warranty shall be invalid if any serious defect is caused by usage of any other fuel. Using fuel other than recommended may cause damage to the fuel injection pump, injector, and other fuel supply system or the engine. CASE CONSTRUCTION may not be responsible to any of such damages.*

If the temperature drops below the fuel cloud point, output deficiency or engine start problems may occur due to wax crystals.

For North America only: during cold weather, lower than **-7 °C (19.4 °F)**, it is temporarily acceptable to use a mixture of No. 1-D (S15) and No. 2-D (S15).

**NOTICE:** *if operating in severe winter climate, consult the fuel supplier or the CASE CONSTRUCTION dealer for specific diesel fuel to be used.*

The diesel fuel to be used on the machine shall:

- be free from dust particles, even minute ones.
- have the proper viscosity.
- have a high cetane number.
- present great fluidity at low temperatures.
- have low sulphur content.
- have very little residual carbon.

**NOTICE:** *never use a mix of diesel fuel and old engine oil. The fuel injection system and the exhaust after treatment system will be severely damaged.*

**NOTICE:** *consult the fuel supplier or the CASE CONSTRUCTION dealer regarding appropriate use of fuel additives.*

**NOTICE:** *in order to prevent condensation during cold weather, fill the fuel tank to full after completing the day's work.*

Fuel storage:

Long storage can lead to the accumulation of impurities and condensation in the fuel. Engine trouble can often be traced to the presence of water in the fuel. The storage tank must be placed outside and the temperature of the fuel should be kept as low as possible. Drain off water and impurities regularly.

## **Disposal of fluids, lubricants, and spare parts**

Fluids, lubricants and spare parts used on the machine are not fully compatible with the environment. Make sure to carry out all maintenance operations using appropriate tools, in order to avoid any risk of damaging the environment.

**NOTE:** *for example, make sure that the receptacle for collecting oil to be replaced is not leaking.*

Never spread fluids or lubricants on the ground or into water. Consult the CASE CONSTRUCTION dealer or the Local Environmental Agency in order to obtain information on the correct method of disposing fluids and lubricants used on the machine.

Never throw away spare parts as filters or batteries. Consult the CASE CONSTRUCTION dealer or the Local Environmental Agency in order to obtain information on the correct method of disposing filters, batteries or other spare parts used on the machine.

---

## Product identification

Your machine is a hydraulic excavator. It consists of an undercarriage fitted with tracks and a swing bearing which supports the upper-structure frame. The upper-structure frame supports the attachment at the front end of the machine, plus the engine, hydraulics and the cab/canopy. When the operator works the controls, the engine-driven pump delivers hydraulic fluid to the control valves. The control valves distribute the hydraulic fluid to the various cylinders and hydraulic motors employed. A cooling system maintains the hydraulic fluid at normal operating temperature.

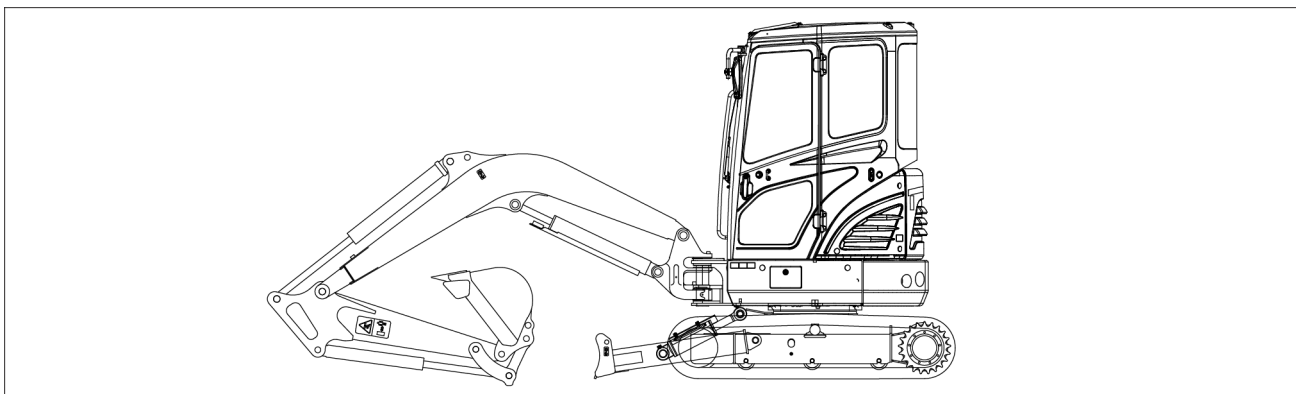

SMIL16MEX0363EA 1

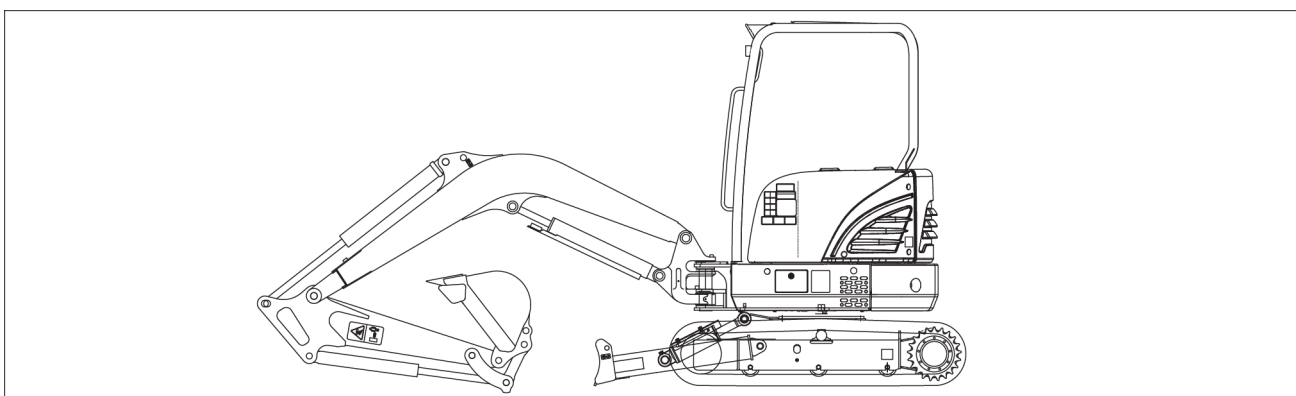
**Cab version**

SMIL16MEX0629EA 2

**Canopy version**

When ordering parts, obtaining information, or seeking assistance, always supply your CASE CONSTRUCTION Dealer with the type and Product Identification Number (PIN) of your machine or accessories.

Write the following in the spaces below:

- Machine Type
- Machine PIN
- Machine year of manufacture
- Serial numbers of hydraulic and mechanical components

## Machine

The machine Product Identification Number (PIN) plate (A) is located below the front window of the operator's cab.

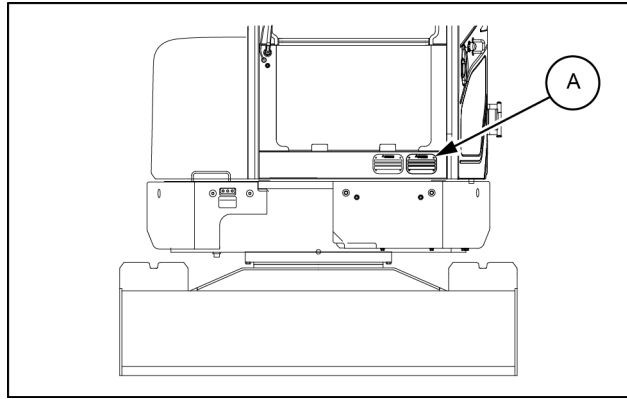

SMIL16MEX1460AB 3

(1) Designation, Type/Model  
Hydraulic Excavator \_\_\_\_\_

(2) Product Identification Number (PIN) \_\_\_\_\_

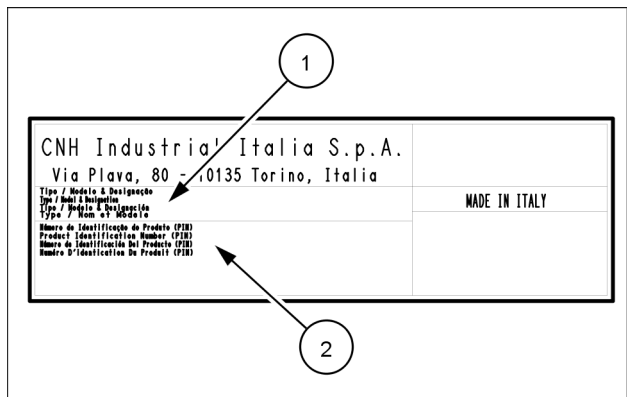

SMIL16MEX1494AA 4

## Engine

The engine serial number (A) is located on the engine name plate.

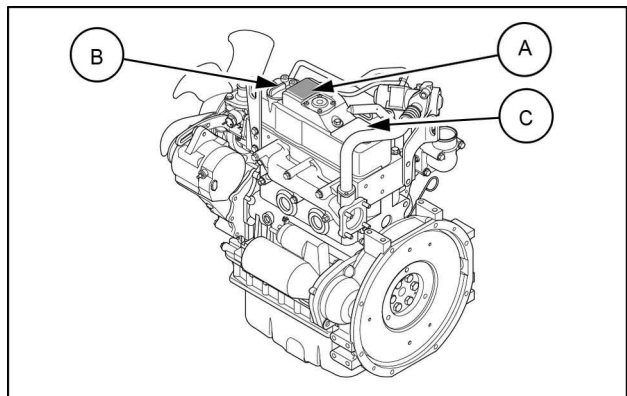

SMIL16MEX1461AB 5

## ID label (B)

This is attached on the cylinder head cover.

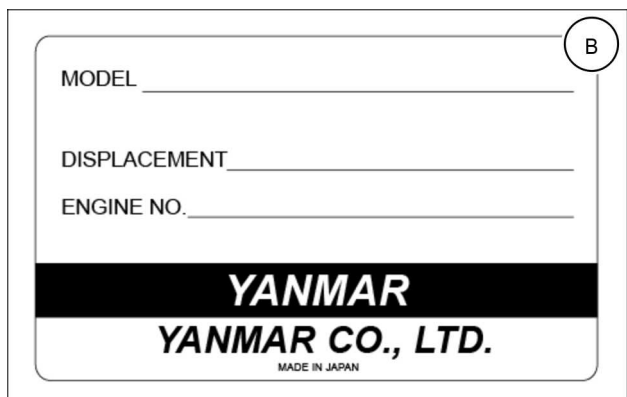

SMIL16MEX1290AA 6

**Emission decal (C)**

The emission decal is affixed on the cylinder head cover. It describes important details for using the engine. Make sure to read before using the engine. Also, the emission decal describes details regarding the engine only.

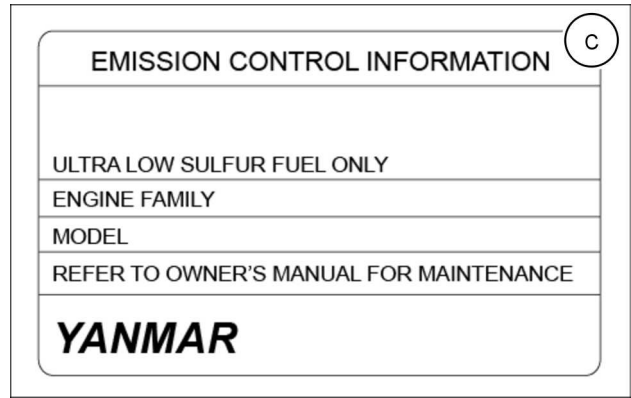

SMIL16MEX1291AA 7

**Structure protection Roll Over Protective Structure ( ROPS)**

Complies with ISO 12117-2 / ISO 10262 LEVEL 1

- (1) Type of protective guard
- (2) Maximum machine mass
- (3) Applicable model
- (4) International standard
- (5) Type

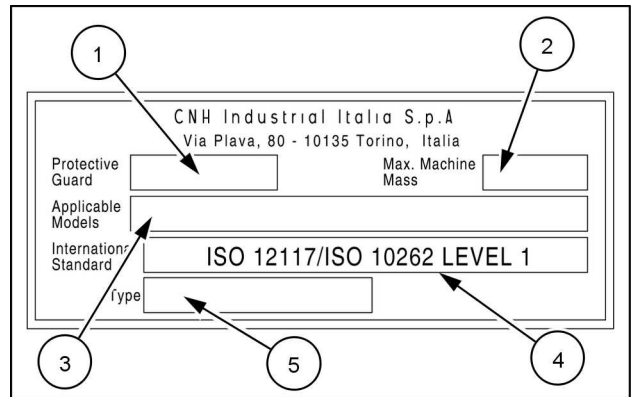

SMIL16MEX0646AA 8

**Component serial numbers**

- Hydraulic pump:
- Swing reduction gear:
- Travel reduction gears:
- Travel control valve:
- Attachment control valve:
- Swing control valve:



## Product identification - Machine orientation

The terms "Right-hand", "Left-hand", "Front" and "Rear" are used in this manual to indicate the sides as they are seen from the operator's seat when the travel motors are positioned at the rear and the operator is facing the direction in which the machine advances (forward).

- A. Front
- B. Rear
- C. Right-hand side
- D. Left-hand side
- E. Travel motor
- F. Idler wheel

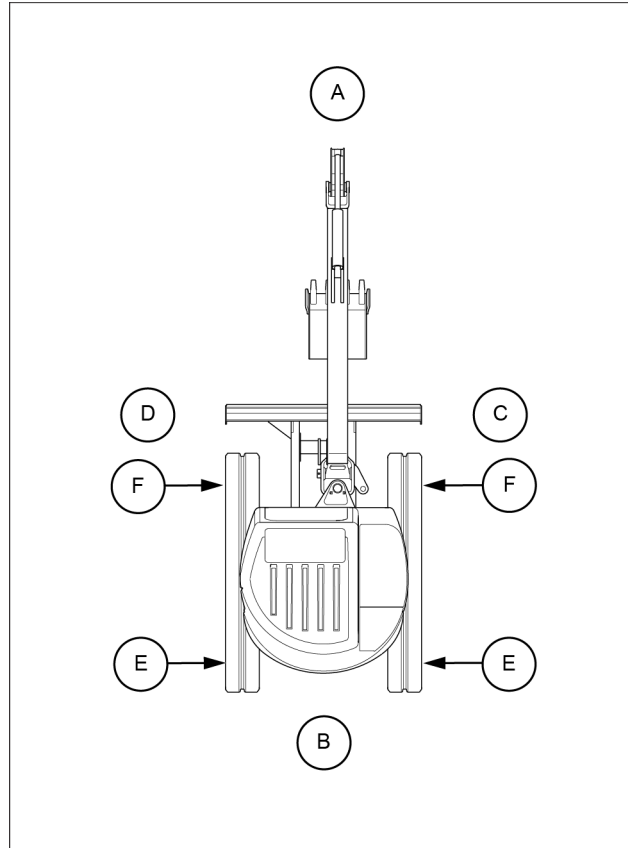

SMIL16MEX0357BB 1



# **SERVICE MANUAL**

## **Engine**

**CX37C Cab - Tier IV final engine**  
**CX37C Canopy - Tier IV final engine**

This as a preview PDF file from [best-manuals.com](http://best-manuals.com)



Download full PDF manual at [best-manuals.com](http://best-manuals.com)