

OPERATING MANUAL

FORTIS®

S40FT, S50FT, S55FTS, S60FT, S70FT (F187)
H40FT, H50FT, H60FT, H70FT (L177)

DO NOT REMOVE THIS MANUAL FROM THIS UNIT

LIFT TRUCK MODEL _____

SERIAL NUMBER _____

ENGINE MODEL _____

SERIAL NUMBER _____

TRANSMISSION TYPE _____

SERIAL NUMBER _____

MAST LIFT HEIGHT _____

GROUP NUMBER _____

CARRIAGE TYPE _____



GROUP NUMBER _____

DRIVE TIRE SIZE _____

STEERING TIRE SIZE _____

SPECIAL EQUIPMENT OR ATTACHMENTS

© Hyster Company 2016. All rights reserved.

HYSTER, , FORTENS, and MONOTROL are Registered Trademarks of Hyster-Yale Group, Inc. DURAMATCH, UNISOURCE, and  are Trademarks in the United States and certain other jurisdictions.

Foreword

To OWNERS, USERS, and OPERATORS:

The **safe and efficient operation of a lift truck** requires skill and alertness on the part of the operator. To develop the skill required the operator must:

- Receive training in the proper operation of THIS lift truck.
- Understand any potential hazards that may exist in the work place where the lift truck is intended to be used.
- Understand the capabilities and limitations of the lift truck.
- Become familiar with the construction of the lift truck and see that it is maintained in good condition.
- Read and properly understand the warnings, instructions, and operating procedures in this manual.

In addition, a qualified person, experienced in lift truck operation, must guide a new operator through several driving and load handling operations before the new operator attempts to operate the lift truck alone.

It is the responsibility of the employer to make sure that the operator can see, hear, and has the physical and mental ability to operate the equipment safely.

Various laws and regulations require the employer to train lift truck operators. These laws and regulations include:

- Occupational Safety and Health Act (USA)
- Canada Material Handling Regulations

NOTE: A comprehensive operator training program is available from **Hyster Company**. For further details, contact your dealer for **Hyster** lift trucks.

This **Operating Manual** is the original instruction and contains information necessary for the operation and maintenance of a basic lift truck. Optional equipment is sometimes installed that can change some operating characteristics described in this manual. Make sure the necessary instructions are available and understood before operating the lift truck.

Some of the components and systems described in this **Operating Manual** will NOT be installed on your unit. If you have a question about any item described, contact your dealer for **Hyster** lift trucks.

Additional information that describes safe operation and use of lift trucks is available from the following sources:

- Employment safety and health standards or regulations (Examples: "Occupational Safety and Health Standards (USA)", "Canada Material Handling Regulations").
- Safety codes and standards (Example: Industrial Truck Standards Development Foundation, ANSI/ITSDF B56.1, *Safety Standard for Low Lift and High Lift Trucks*).
- Publications from government safety agencies, government insurers, private insurers and private organizations (Example: *Accident Prevention Manual for Industrial Operations*, from the National Safety Council).
- *Guide for Users of Industrial Lift Trucks* (Hyster Part No. 852930) describes lift truck safety, good maintenance practices, and training programs and is available from your dealer for **Hyster** lift trucks.

- *Lift Truck/Pedestrian Accidents, Causes and Prevention*. Hyster Company (LIFTPED/B 12/2003).

NOTE: Hyster lift trucks are not intended for use on public roads.

NOTE: The following symbols and words indicate safety information in this manual:



WARNING

Indicates a hazardous situation which, if not avoided, could result in death or serious injury.



CAUTION

Indicates a hazardous situation which, if not avoided, could result in minor or moderate injury and property damage.

On the lift truck, the **WARNING** symbol and word are on orange background. The **CAUTION** symbol and word are on yellow background.

Contents

Foreword	1	Operator Passwords	69
TO OWNERS, USERS, AND OPERATORS:	1	Starting Procedures	71
Warning	7	Starting Procedures, Trucks With Key Switch	71
Model Description	10	Starting Procedures, Trucks With Keyless Start Option	73
GENERAL	11	Checks With the Engine Running	74
OPERATOR PROTECTION EQUIPMENT	14	Load Weighing Sensor	75
NAMEPLATE	15	Set Load Weight to Zero	76
SAFETY LABELS	16	Engine Shutdown	76
DISPLAY SWITCH CLUSTER	21	OPERATING TECHNIQUES	77
Display Switch Cluster – Right-Side Display Inputs ..	21	Basic Operating Procedures	78
Display Switch Cluster – LCD Screen and Warning and Indicator Lights	28	Driving and Direction Changes	83
OPERATOR CONTROLS	37	General	85
OPERATOR CONTROLS – JOYSTICK FEATURES ..	57	Normal Operations	85
Operating Procedures	63	Standard Operator Presence System	86
GENERAL	63	Optional Operator Presence System	87
Know Your Lift Truck	63	Basic Powershift and Powershift 1 Speed Transmissions	87
Stability and Center of Gravity	65	DuraMatch	88
Capacity (Weight and Load Center)	66	Inching	90
Impact Sensor	67	Steering (Turning)	91
INSPECTION BEFORE OPERATION	68	Load Handling, General	92
Checks With the Engine Stopped	68	Load Handling, Lifting, Lowering, and Tilting	93
Mounting and Dismounting	69		

Load Handling, How to Engage and Disengage a Load	96	Tires and Wheels	150
Load Handling, Traveling	99	Safety Labels	152
Load Handling, Emergency Load Lowering	103	Mast, Carriage, Header Hoses, Lift Chains, and Attachment	152
HIGHWAY TRUCKS, RAIL CARS, AND DOCKS	105	Operator Restraint System	154
ATTACHMENTS	106	Automatic Locking Retractor (ALR)	157
Disconnecting Attachment Hydraulic Quick-Disconnect Hoses	107	Emergency Locking Retractor (ELR)	158
Connecting Attachment Hydraulic Quick-Disconnect Hoses	108	Hood and Seat Latches	158
STOPPING	108	Engine Compartment	160
PARKING	109	Paper Application	160
Maintenance	110	Fuel, Oil, and Coolant Leaks, Check	162
GENERAL	110	Hydraulic Hoses	162
Serial Number Data	111	Coolant Hoses	162
HOW TO MOVE A DISABLED LIFT TRUCK	111	Steering Column Gas Cylinder	163
How to Tow the Lift Truck	111	Transmission	163
HOW TO PUT A LIFT TRUCK ON BLOCKS	112	Hydraulic System Oil	164
How to Raise the Drive Tires	112	Engine Oil	164
How to Raise the Steering Tires	113	Air Filter	169
HOW TO CLEAN A LIFT TRUCK	113	Forks	169
Maintenance Schedule	114	Forks, Remove	169
Maintenance Procedures Every 8 Hours or Daily	150	Forks, Inspect	172
HOW TO MAKE CHECKS WITH THE ENGINE STOPPED	150	Forks, Install	172
		Forks, Adjust	173
		HOW TO MAKE CHECKS WITH THE ENGINE RUNNING	175

Indicator Lights, Horn, Fuses, and Relays	175	Install Wheel in Tire	195
Service Brakes	177	Tire Installation, Three- or Four-Piece Wheel	196
Brake Fluid Level	177	Tire Installation, Two-Piece Wheel	197
Operation, Check	177	Add Air to Pneumatic Tires With Tube	198
Parking Brake	178	Install the Wheels	199
Engine Oil Pressure	179	PNEUMATIC TUBELESS TIRE, REPAIR	199
Cooling System	179	Remove Tire From Lift Truck	199
Steering System	181	Remove Tire From Wheel	200
Control Levers and Pedals	181	Install Tire on Wheel	202
Lift System Operation	181	Add Air to Pneumatic Tubeless Tire	205
HOW TO ADD FUEL TO THE LIFT TRUCK	182	Install the Wheels	206
Liquefied Petroleum Gas (LPG)	183	SOLID RUBBER TIRES ON PNEUMATIC WHEELS, CHANGE	206
LPG Tank, Remove	184	Remove Tire From Wheel	206
LPG Tank, Fill	186	Install Tire on Wheel	208
LPG Tank, Install	187	DUAL DRIVE WHEELS, INSTALL	210
Gasoline or Diesel Fuel	188	JUMP-STARTING THE LIFT TRUCK	211
WHEELS AND TIRES	188	Jump-Starting Using a Battery Charger	211
General	188	Jump-Starting Using Another Lift Truck	211
How to Change a Solid Rubber Tire (S Series)	188	JUMP-STARTING THE LIFT TRUCK	212
Remove and Install the Tire on the Wheel	189	Jump-Starting Using a Battery Charger	212
PNEUMATIC TIRE WITH TUBE, REPAIR	191	Jump-Starting Using Another Lift Truck	212
Remove Wheels From Lift Truck	191	OPERATING PROCEDURES FOR A NEW OR REBUILT ENGINE	213
Remove Tire From Wheel	191	CHANGES TO THE OVERHEAD GUARD	213
Tire Removal, Two-Piece Wheel	193		
Tire Removal, Three- and Four-Piece Wheels	194		

Contents

HYSTER

HOW TO PUT INTERNAL COMBUSTION ENGINE (ICE) TRUCKS IN STORAGE	213	HOW TO MOVE A LIFT TRUCK ON A TRANSPORT	217
Short-Term Storage	214	Loading	218
Long-Term Storage	215	Unloading	219
While the Lift Truck is in Storage	215	PREPARATION FOR USE	219
How to Put Batteries in Storage	215	Preparation After Transport	219
Putting a Stored Lift Truck Back Into Service	216		

 **WARNING**

**FAILURE TO FOLLOW THESE INSTRUCTIONS CAN CAUSE SERIOUS INJURY OR DEATH!
AUTHORIZED, TRAINED OPERATOR ONLY!**

KNOW THE EQUIPMENT:

- ALWAYS use 3 points of contact when getting on and off the truck.
- KNOW operating, inspection, and maintenance instructions in **Operating Manual**.
- **DO NOT** operate or repair truck unless trained and authorized.
- INSPECT truck before use.
- **DO NOT** operate if truck needs repair. Tag truck and remove key. Repair truck before use. Always use **Hyster Approved** parts when making repairs. Replacement parts must meet or exceed the specifications of the original equipment manufacturer.
- USE auxiliary equipment (attachments) for intended purpose only.

- VERIFY truck is equipped with overhead guard and load backrest adequate for the load.

LOOK WHERE YOU ARE GOING:

- IF YOU CAN'T SEE, DON'T GO.
- TRAVEL in reverse if load blocks forward vision.
- MAKE SURE tail swing area is clear.
- SOUND horn at intersections or where vision is blocked.
- WATCH clearances, especially overhead.

KNOW YOUR LOADS:

- HANDLE only stable loads within specified weight and load center. See Nameplate on truck.
- DO NOT handle loose loads higher than load backrest.
- SPACE forks as far apart as load allows and center load between forks. Keep load against load backrest.

 **WARNING**

**FAILURE TO FOLLOW THESE INSTRUCTIONS CAN CAUSE SERIOUS INJURY OR DEATH!
AUTHORIZED, TRAINED OPERATOR ONLY!**

USE COMMON SENSE:

- DO NOT use truck to lift people unless there is no other practical option. Then, use only a securely attached special work platform. Follow instructions in this Operating Manual.
- OBEY traffic rules. Yield right-of-way to pedestrians.
- BE in complete control at all times.
- ALLOW NO ONE under or near lift mechanism or load.
- OPERATE truck only from operator's seat.
- KEEP arms, legs, and head inside operator's compartment.
- DO NOT move truck if anyone is between truck and stationary object.
- BEFORE DISMOUNTING, neutralize travel control, lower carriage, and set brake.

- WHEN PARKING, also shut off power, close LPG fuel valve, block wheels on inclines.

KNOW THE AREA:

- NEVER enter a trailer or railroad car unless its wheels are blocked.
- CONFIRM floor strength.
- FILL fuel tank or charge battery only in designated area.
- TURN OFF engine when fueling.
- AVOID sparks or open flame. Provide ventilation.
- DO NOT start if fuel is leaking.
- KEEP vent caps clear when charging battery.
- DISCONNECT battery during servicing.
- CHECK dockboard width, capacity, and security.

 **WARNING**

**FAILURE TO FOLLOW THESE INSTRUCTIONS CAN CAUSE SERIOUS INJURY OR DEATH!
AUTHORIZED, TRAINED OPERATOR ONLY!**

PROTECT YOURSELF FASTEN YOUR SEAT BELT!

- AVOID bumps, holes, and loose materials.
- AVOID sudden starts or stops.
- NEVER turn on or angle across an incline.
- TRAVEL on inclines with load uphill or when unloaded with lift mechanism downhill.
- TILT mast slowly and smoothly. LIFT or LOWER with upright vertical or tilted slightly back. Use minimum tilt when stacking elevated loads.

- TRAVEL with carriage as low as possible and tilted back.
- SLOW DOWN before turning, especially without load.

**FAILURE TO FOLLOW THESE INSTRUCTIONS CAN
CAUSE THE LIFT TRUCK TO TIP.**

DO NOT JUMP off if the truck tips over. HOLD steering wheel firmly. BRACE your feet. LEAN FORWARD and AWAY from point of impact.

Model Description

HYSTER

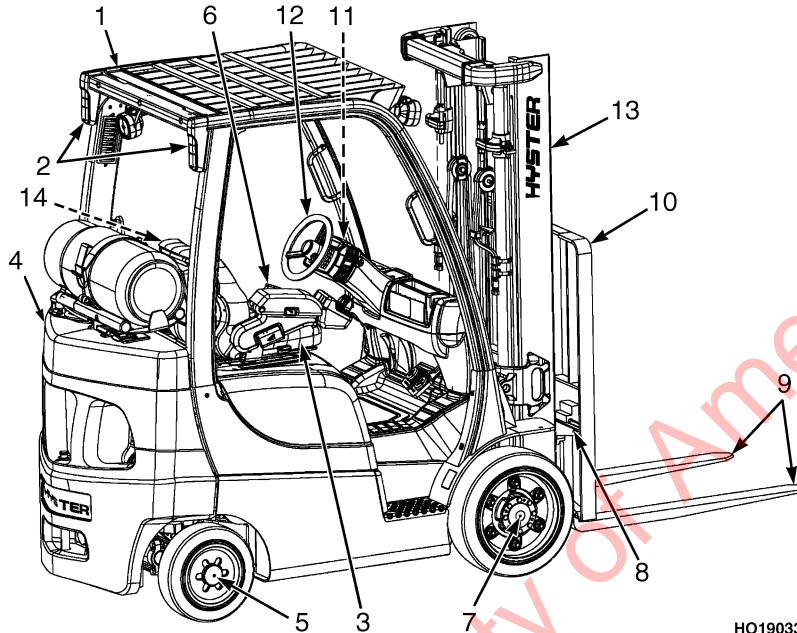

COMPONENTS FOR H40-70FT TRUCKS ARE IN SAME LOCATIONS.

1. OVERHEAD GUARD
2. TAIL, BRAKE, AND REVERSE LIGHTS
3. SEAT
4. COUNTERWEIGHT
5. STEERING AXLE
6. SEAT BELT AND HIP RESTRAINT
7. DRIVE AXLE
8. CARRIAGE
9. FORKS
10. LOAD BACKREST EXTENSION
11. PARKING BRAKE
12. STEERING WHEEL
13. MAST
14. OPERATING MANUAL (BEHIND SEAT)

HO190333

Figure 1. Model View Showing Major Components of S40-70FT, S55FTS Series

Model Description

General

This **Operating Manual** is for the following models of lift trucks:

S40FT, S50FT, S55FTS, S60FT, and S70FT (F187)

H40FT, H50FT, H60FT, and H70FT (L177)

These lift trucks are available with the following engines:

- Mazda 2.0L engine which uses gasoline or LPG fuel
- Mazda 2.2L engine which uses gasoline or LPG fuel
- GM 2.4L engine which uses gasoline or LPG fuel
- Yanmar 2.6L engine which uses diesel fuel
- Yanmar 3.3L engine which uses diesel fuel

Prior to January, 2011, these lift truck models can be equipped with a Basic Powershift (iron case), Powershift 1 Speed (aluminum case gear drive) or DuraMatch transmission (see **Table 1**). After January 2011, these truck models will be equipped with a Powershift 1 Speed (aluminum case chain drive) or DuraMatch transmission (see **Table 1**) and can be equipped with three types of controls:

- A MONOTROL® pedal that controls both the forward and reverse operation of the powershift transmission and the speed of the engine.
- A Direction Control Lever on the left side of the Display Switch Cluster that controls the forward, neutral, and reverse operation of the powershift transmission. A separate accelerator pedal controls the engine speed.
- A directional control switch integrated into the armrest on units equipped with E-hydraulics controls both forward and reverse operation of the transmission. A separate accelerator pedal controls engine speed.

The S40-70FT lift trucks are equipped with solid rubber tires. The H40-70FT lift trucks are equipped with pneumatic tires or solid pneumatic-shaped tires. See **Wheels and Tires** in the **Maintenance Section** for a description of these tires.

If your lift truck is an S40-70FT, S55FTS (F187) with manual hydraulics and manufactured prior to March, 2009, it is not equipped an emergency lowering valve. If manufactured after March, 2009, it is equipped with an emergency lowering valve.

Model Description

HYSTER

If your lift truck is an H40-70FT (L177) with manual hydraulics and manufactured prior to March, 2009, is it not equipped with an emergency lowering valve. If manufactured after March, 2009, it is equipped with an emergency lowering valve.

If your lift truck is equipped with electronic hydraulics, it has an emergency lowering valve.

This emergency lowering valve (see **Figure 15**) allows the operator or service technician to lower the lift truck's mast assembly if the electrical signal to the main control valve is disrupted. See the section **Load Handling, Emergency Load Lowering** in the **Operating Procedures** section.

Table 1. Transmissions

Operational Feature	Basic Powershift or Powershift 1 Speed Transmission	DuraMatch Transmission
Electronic Inching	Yes	Yes
Electronic Control of Direction Changes	Yes	Yes
Auto Deceleration	–	Yes
Controlled Power Reversal	–	Yes
Roll Reduction Feature	–	Yes
Roll Back Feature	–	Yes
Reduced Drive Tire Slippage	–	Yes



HO210009

1. BASIC POWERSHIFT TRANSMISSION
2. DURAMATCH TRANSMISSION
3. POWERSHIFT 1 SPEED TRANSMISSION

Figure 2. Transmission Labels

Operator Protection Equipment

The LOAD BACKREST EXTENSION is installed to keep loose parts of the load from falling back toward the operator. It must be high enough, with vertical openings small enough, to prevent the parts of the load from falling backwards. If a load backrest extension that is different from the one installed on your lift truck is required, contact your **Hyster** lift truck dealer.

The OVERHEAD GUARD is intended to offer reasonable protection to the operator from falling objects, but cannot protect against every possible impact. Therefore, it must

not be considered a substitute for good judgment and care when handling loads. Do not remove the overhead guard.

NOTE: The seat belt can be either black or red.

The SEAT BELT AND HIP RESTRAINT provide additional means to help the operator keep the head and torso substantially within the confines of the lift truck frame and overhead guard if a tipover occurs. This restraint system is intended to reduce the risk of the head and torso being trapped between the lift truck and the ground, but it cannot protect the operator against all possible injury in a tipover. The hip restraint will help the operator resist side movement. It is not a substitute for the seat belt. Always fasten the seat belt.

This lift truck may be equipped with an optional operator presence system which will not allow the truck to travel unless the seat belt is fastened. When equipped, the seat belt interlock includes sequencing/logic for the seat pressure switch and seat belt switch. The weight of the operator must be detected prior to the seat belt switch being engaged to enable operations.

Nameplate

WARNING

DO NOT add to or modify the lift truck. Any modification that affects the safe operation of the truck cannot be undertaken without the written authorization of Hyster Company.

Any change to the lift truck, the tires, or its equipment can change the lifting capacity. The lift truck must be rated as equipped and the Nameplate must show the new capacity rating.

The capacity is specified in kilograms (kg) and pounds (lb). The capacity is the maximum load that the lift truck can handle for the load condition shown on the Nameplate.

The maximum capacity for the lift truck, at full load height, must be shown on the Nameplate. Special capacities with the load height reduced or with optional load centers, may also be shown on the Nameplate.

The lift truck serial number code is on the Nameplate. The serial number code is also stamped on the right-hand side of the lift truck frame, under the floorplate.

When a lift truck is shipped incomplete from the factory, the Nameplate is covered by an INCOMPLETE label as shown in **Figure 3**. If the equipment on the truck is changed, the Nameplate is covered by a NOTICE label as shown in **Figure 3**. If your lift truck has either of these labels, do not operate the lift truck. Contact your dealer for lift trucks to obtain a complete and correct Nameplate.

! WARNING

Trained Operators and Mechanics only

Read Operating Manual located on or near seat.

Failure to follow operating, inspection, and maintenance instructions can cause serious injury or death!

CAPACITY WITH MAST VERTICAL AND EQUIPPED AS SHOWN

Attachment		Truck Weight		kg (lb)	Back Tilt	Degrees
Tire		Front	Rear			
Size						
Pressure						
Tread Width		mm (lb)				

MAXIMUM CAPACITY	Load Height		Load Center	
	Dim. A	Dim. B	Dim. C	
kg lb	mm in	mm in	mm in	mm in
()	()	()	()	()

A

NOTICE TO USER

The U.S.A. Occupational Safety and Health Act of 1970 and other national safety codes require a new plate if this unit is equipped other than as stated on plate. Obtain the correct plate from your authorized dealer.

INCOMPLETE PLATE

INCOMPLETE

NOTICE TO USER

This unit was shipped incomplete from the factory. A complete nameplate **MUST** be obtained through your Hyster dealer **BEFORE** this unit is placed in operation.

B
C

HO190385

Safety Labels

Safety labels are installed on the lift truck to provide information about possible hazards. It is important that all safety labels are installed on the lift truck and can be read. See **Figure 4**.

All possible label configurations that can be on the lift trucks covered in this **Operating Manual** are not shown in **Figure 4**. See the **Parts Manual** for label part numbers and a complete listing of all labels that are available for the lift trucks covered in this **Operating Manual**.

- A. NAMEPLATE
- B. NOTICE LABEL
- C. INCOMPLETE LABEL

Figure 3. Nameplate and Labels

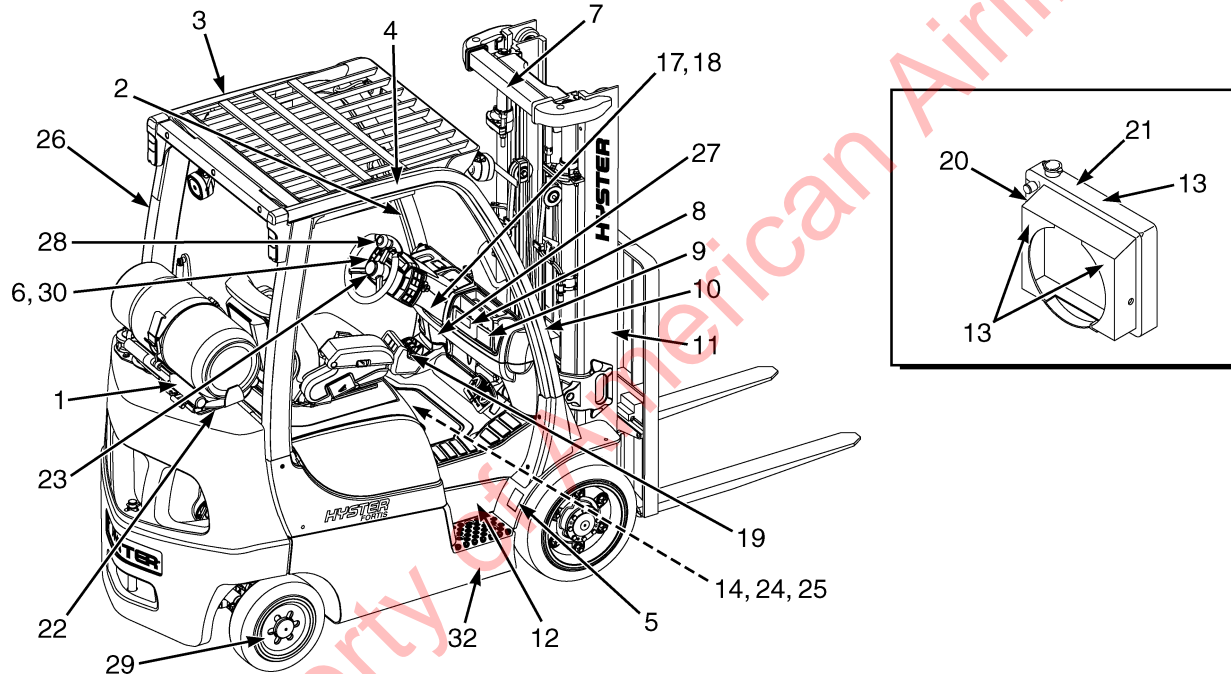

LABELS FOR H40-70FT TRUCKS ARE IN SAME LOCATIONS.

Figure 4. Warning and Safety Labels (Sheet 1 of 3)

HO190406

1

2

3

4

5

6

6*

11

12

7

8

CAPACITY WITH MAST	VERTICAL AND		EQUIPPED AS SHOWN	
	kg	min	kg	min
(A)	kg	min	kg	min
(B)	kg	min	kg	min
(C)	kg	min	kg	min

9

10

SEE THE PARTS MANUAL FOR THE PART NUMBER.

Figure 4. Warning and Safety Labels (Sheet 2 of 3)

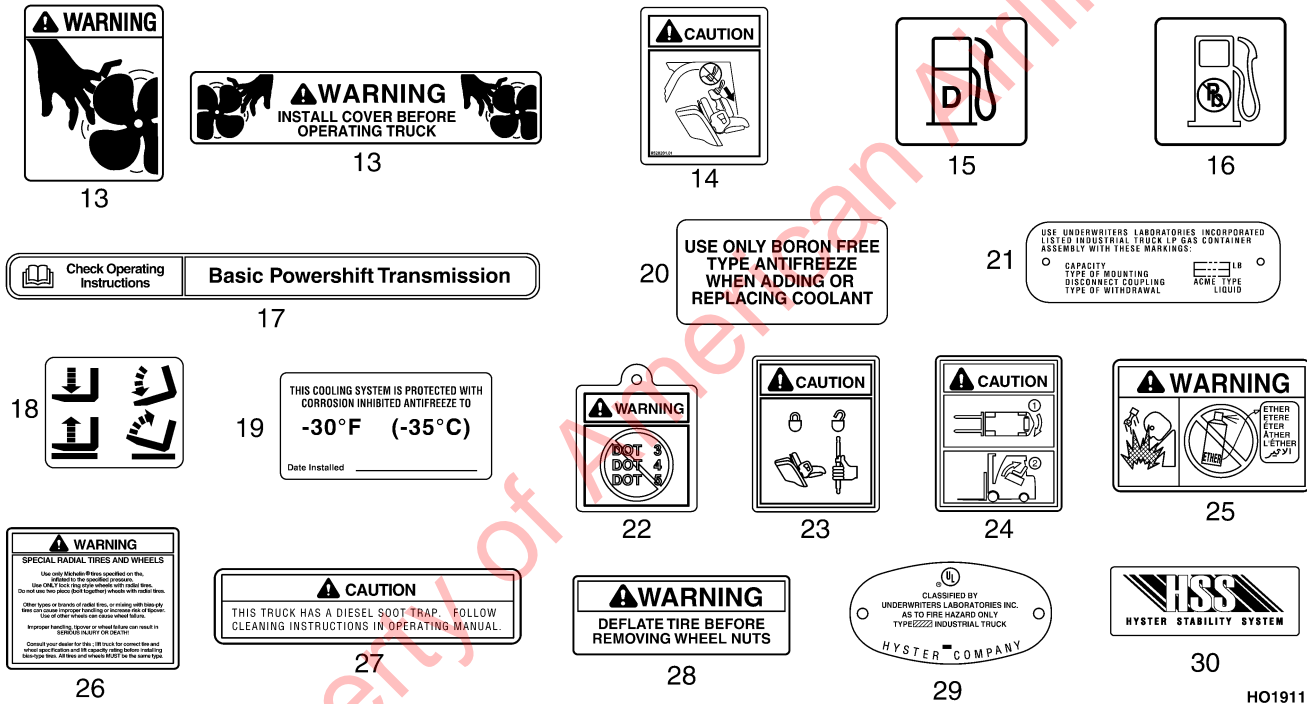

SEE THE PARTS MANUAL FOR THE PART NUMBER.

Figure 4. Warning and Safety Labels (Sheet 3 of 3)

Legend for Figure 4

- | | | |
|-----------------------------------|---------------------------------------|---|
| 1. FLAMMABLE LP-GAS | 11. MAST WARNING | 21. LPG TANK WARNING |
| 2. TIPOVER WARNING | 12. OPTIONAL FIRE SAFETY RATING | 22. BRAKE FLUID WARNING (PNEUMATIC TRUCKS ONLY) |
| 3. OVERHEAD GUARD LABEL | 13. FAN WARNING | 23. LOCKING GAS SPRING |
| 4. WARNING, OPERATION | 14. JOYSTICK LABEL | 24. HOOD OPENING CAUTION |
| 5. NO RIDERS | 15. DIESEL FUEL LABEL (NOT SHOWN) | 25. EITHER WARNING (DIESEL ONLY) |
| 6. WARNING FOR PARKING BRAKE | 16. UNLEADED FUEL LABEL (NOT SHOWN) | 26. RADIAL TIRES AND WHEELS (PNEUMATIC TIRES ONLY) |
| 7. MAST WARNING | 17. TRANSMISSION LABEL (EXAMPLE ONLY) | 27. SOOT TRAP WARNING (DIESEL ONLY) |
| 8. NAMEPLATE | 18. LIFT AND TILT LABEL | 28. SPLIT WHEEL WARNING (PNEUMATIC TIRES ONLY) |
| 9. DRIVE TRAIN PROTECTION CAUTION | 19. ANTIFREEZE WARNING | 29. UL LABEL |
| 10. NO ONE ON OR UNDER FORKS | 20. BORON-FREE LABEL | 30. STABILITY SYSTEM LABEL (ON BOTH SIDES OF TRUCK)** |

*THIS PARKING BRAKE LABEL (SEE SHEET 2) USED ON LIFT TRUCKS MANUFACTURED AFTER JANUARY, 2012.

**THIS LABEL USED ON LIFT TRUCKS MANUFACTURED AFTER JANUARY, 2012.

Display Switch Cluster

WARNING

If any of the instruments, levers, or pedals do not operate as described in the following tables, report the problem immediately. **DO NOT** operate the lift truck until the problem is corrected.

NOTE: On the lift truck models covered in this manual, the left side (see **Figure 5**) of the Display Switch Cluster does not perform any functions.

Display Switch Cluster – Right-Side Display Inputs

The lift trucks covered in this manual can have several different options and configurations. Depending on the equipment on the lift truck, warning and indicator lights on the right side of the Display Switch Cluster will vary and the truck may not contain all the warning and indicator lights shown in **Figure 6** and **Table 2**.

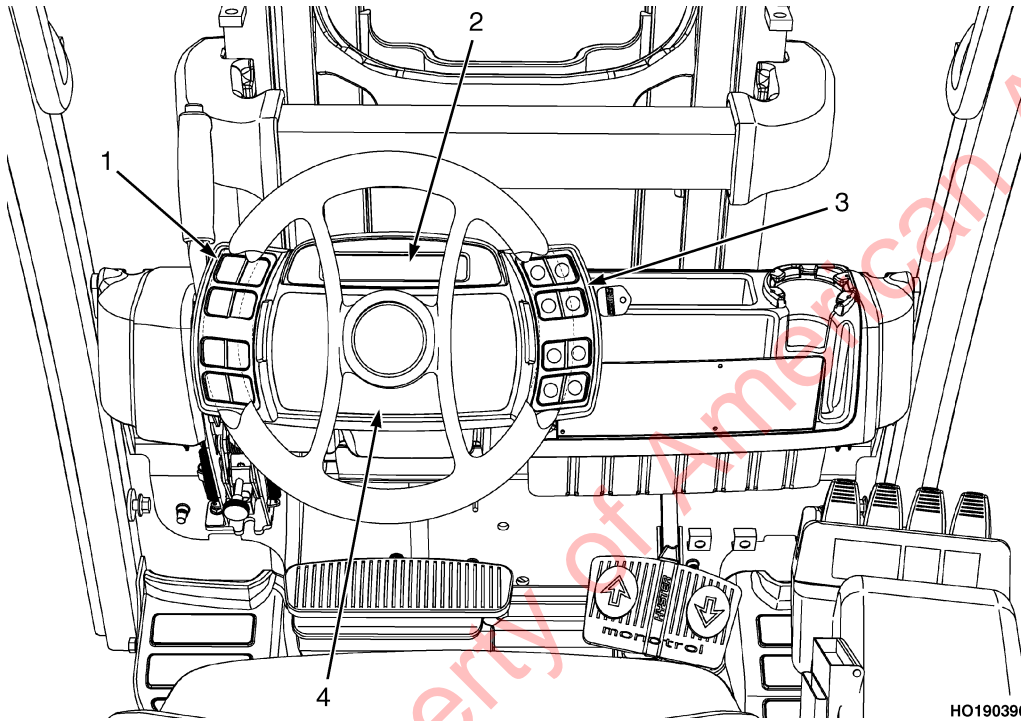

- 1. LEFT SIDE DISPLAY INPUTS
- 2. LCD SCREEN
- 3. RIGHT SIDE DISPLAY INPUTS
- 4. WARNING AND INDICATOR LIGHTS

Figure 5. Display Switch Cluster

HO190396

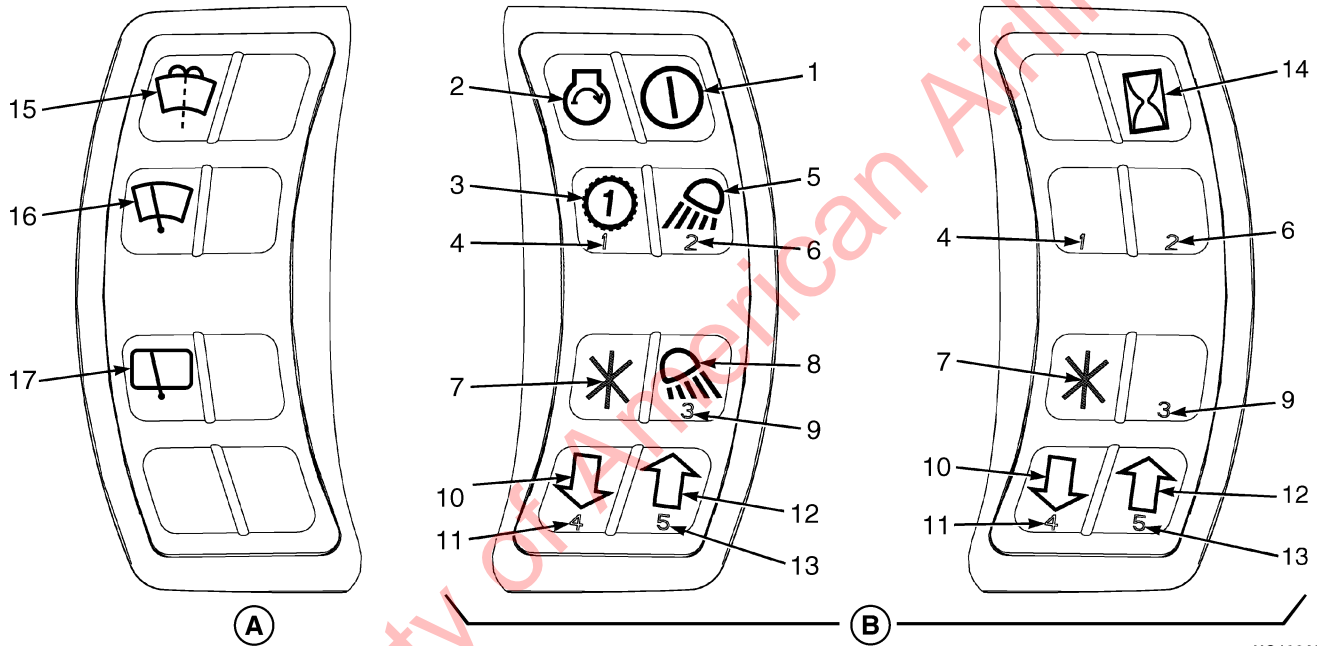

HO190432

A. LEFT SIDE DISPLAY – CAB OPTION H40-70FT ONLY

B. RIGHT SIDE DISPLAY

Figure 6. Display Switch Cluster

Table 2. Display Switch Cluster – Right-Side Display Inputs (See Figure 6)





Item No.	Item	Function
1	Power ON/OFF 	If the lift truck is equipped with the keyless start option, lift truck system power is turned ON by pressing this button. To turn the lift truck system power and engine OFF , press the Power ON/OFF button again. If lift truck has a key switch, the Power ON/OFF symbol is replaced with the Hourmeter symbol.
2	Engine Start 	This button is used when the lift truck is equipped with the keyless start option. The engine is started by pressing and holding this button. Lift truck power must be turned ON (pressing Power ON/OFF button) before starting engine. If the lift truck contains a key switch, the Engine Start graphic is covered and the function disabled.
	1st Gear Locking Button 	This button engages and disengages the 1st Gear Locking function on trucks equipped with a the DuraMatch plus 2 transmission.
4	#1 Button	When an operator or supervisor is in the main menu for entering and administering passwords, this button is used to enter the number 1 for password purposes.
5	Front Work Lights 	This button controls the front work lights and the marker lights on lift trucks equipped with this option.

Table 2. Display Switch Cluster – Right-Side Display Inputs (See Figure 6) (Continued)



Item No.	Item	Function
6	#2 Button	<p>If the lift truck is equipped with front work lights, the #2 Button and the Front Work Light button will share space on the Display Switch Cluster.</p> <p>When an operator or supervisor are in the main menu for entering and administering passwords, the Front Work Lights function is disabled and the button is enabled to enter the number 2 for password purposes. If the lift truck is not equipped with Front Work Lights, then this button functions only as Password entry #2.</p>
7	Enter Button 	<p>This button is used for menu entry, navigation, and data entry.</p>
8	Rear Work Lights 	<p>This button controls the rear work lights on lift trucks equipped with this option.</p>
9	#3 Button	<p>If the lift truck is equipped with rear work lights, the #3 Button and the Rear Work Light button will share space on the Display Switch Cluster.</p> <p>When an operator or supervisor is in the main menu for entering and administering passwords, the Rear Work Lights function is disabled and the button is enabled to enter the number 3 for password purposes. If the lift truck is not equipped with rear work lights, then this button functions only as Password entry #3.</p>

Table 2. Display Switch Cluster – Right-Side Display Inputs (See Figure 6) (Continued)







Item No.	Item	Function
10	Scroll Down 	This button is used for the following functions: <ul style="list-style-type: none"> • Decreasing the value of a selected operating function • Scrolling downward through a list of possible menu selections
11	#4 Button	The Scroll Down and #4 Button share the same space on the Display Switch Cluster. When an operator or supervisor is in the main menu for entering and administering passwords, the Scroll Down function is disabled and the button is enabled to enter the number 4 for password purposes.
12	Scroll Up 	This button is used for the following functions: <ul style="list-style-type: none"> • Increasing the value of a selected operating function • Scrolling upward through a list of possible menu selections
13	#5 Button	The Scroll Up and #5 Button share the same space on the Display Switch Cluster. When an operator or supervisor is in the main menu for entering and administering passwords, the Scroll Up function is disabled and the button is enabled to enter the number 5 for password purposes.

Table 2. Display Switch Cluster – Right-Side Display Inputs (See Figure 6) (Continued)

Item No.	Item	Function
14	Hourmeter 	<p>On trucks with key switch start, when truck is ON, engine hours will be displayed on LCD screen on right side of second line. When truck is OFF, press hourmeter button to display engine hours.</p> <p>On trucks with keyless start option, when truck is ON, engine hours will be displayed on LCD screen on right side of second line. When truck is OFF, engine hours can be displayed when accessing menu to enter password. Password not required to view engine hours.</p> <p>Periodic Maintenance recommendations are based on these hours.</p>
15	Windshield Washer 	<p>On lift trucks with the cab option, press this button to wash the front windshield. Windshield wipers will turn on and off automatically.</p>
16	Front Windshield Wiper 	<p>On lift trucks with cab option, press this switch to turn the front windshield wiper ON. Press the switch again to turn the front windshield wiper OFF.</p>
17	Rear Windshield Wiper 	<p>On lift trucks with cab option, press this switch to turn the rear windshield wiper ON. Press the switch again to turn the rear windshield wiper OFF.</p>

Display Switch Cluster – LCD Screen and Warning and Indicator Lights

The LCD screen (see **Figure 7**) shows operator messages for the different functions. The LCD screen can display messages on two lines with up to 20 characters per line. Bar graphs are also shown on the display using solid block characters of varying heights.

The following information is displayed on the LCD screen when the truck is running:

- Engine coolant temperature (standard)
- Fuel level, diesel and gasoline engines (standard)

The engine coolant temperature is displayed on the top line and the fuel level is shown on the bottom line. If load weight and travel speed options are available, press the scroll down button to display the information for these features. Press the scroll up button to return to the engine

coolant temperature and fuel level displays. If a fault occurs, the fault number will be displayed on the top line. The time of day is displayed on the right side of the top line at all times during the selection of displayed text. "HYD TEMP/FUNCTION REDUCED" is displayed when the hydraulic oil temperature is higher or lower than specified limits.

The warning lights and indicator symbols shown in **Figure 7** are on all lift truck models. Depending on the equipment on the lift truck, the warning and indicator lights on the Display Switch Cluster will vary and not all the warning and indicator lights shown in **Figure 7** will illuminate. When the warning lights and indicators are on, the operator will see the appropriate symbol. When the warning lights and indicators are off, the operator will see a black panel. Unless noted in **Table 3**, all programmed warning and indicator lights will light up for two seconds (Start Check) when System Power is turned **ON**.

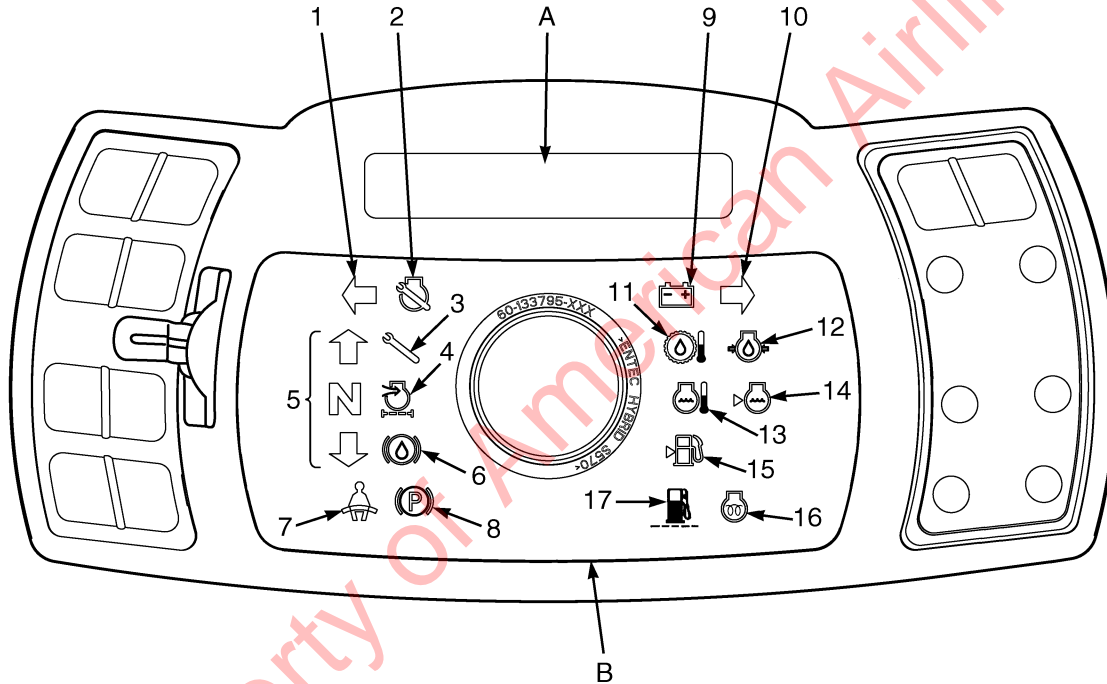

A. LCD SCREEN

B. WARNING AND INDICATOR LIGHTS

Figure 7. Display Switch Cluster – LCD Screen and Warning and Indicator Lights

BO190164

Table 3. Instruments – Warning and Indicator Lights (See Figure 7)





Item No.	Item	Function
1	Indicator Light Left Turn Signal 	This green indicator will blink on and off when the left turn signal is selected. Not on at Start Check.
2	Warning Light, Engine Malfunction Indicator 	This amber indicator is on when the system is in the ON state, and turns off as the RUN state is entered. This indicator will also illuminate when an engine related fault has occurred. Not on at Start Check.
3	Warning Light, System Malfunction Indicator 	This amber light will illuminate when a fault that is not engine related occurs.
4	Indicator Light Air Filter Restriction 	If the lift truck is equipped with the premium monitoring package, this amber Air Filter Restriction light will illuminate when the air filter restriction switch senses a restriction in the air filter.
5	Indicator Lights Direction and Transmission Lights 	The green direction lights will illuminate when the operator selects the direction of travel. When the transmission is put into NEUTRAL , the green N illuminates and stays lit until transmission is not in NEUTRAL .

Table 3. Instruments – Warning and Indicator Lights (See Figure 7) (Continued)







Item No.	Item	Function
6	Warning Light, Brake Fluid Level Malfunction Indicator 	 CAUTION Do not continue to operate the lift truck if the light is on during operation. The red brake fluid light will illuminate when the brake fluid level switch indicates a low fluid condition.
7	Warning Light, Fasten Seat Belt Malfunction Indicator 	 WARNING Always fasten the seat belt when operating the lift truck. The red light is illuminated for 10 seconds after system power is turned ON . Not on at Start Check.
8	Warning Light, Parking Brake Malfunction Indicator 	 WARNING Always apply the parking brake when leaving the lift truck. The red parking brake light will illuminate any time the system power is ON and the parking brake lever is moved into the applied position. The indicator light will flash any time the Parking Brake Warning alarm is active. Not on at Start Check.
9	Warning Light, Alternator Malfunction Indicator 	The red Alternator light will illuminate when the system is not in the OFF state and the alternator is not in a charging state. This includes illuminating at System Power On until the normal operating minimum is reached. Not on at Start Check.

Table 3. Instruments – Warning and Indicator Lights (See Figure 7) (Continued)



Item No.	Item	Function
10	Indicator Light Right Turn Signal 	This green indicator will blink on and off when the right turn signal is selected. Not on at Start Check.
11	Warning Light, Transmission Oil Temperature Malfunction Indicator 	<p>CAUTION Do not continue to operate the lift truck if the red light is ON.</p> <p>The red light will illuminate when the transmission oil temperature reaches the pre-set warning level.</p> <p>When light illuminates, and if truck is equipped with optional powertrain protection, truck performance will decrease. Turn truck OFF and notify service person immediately for repair. If truck is not equipped with optional powertrain protection and light is illuminated when engine is running, turn engine OFF immediately and have truck repaired by service technician.</p>

Table 3. Instruments – Warning and Indicator Lights (See Figure 7) (Continued)



Item No.	Item	Function
12	Warning Light, Engine Oil Pressure Malfunction Indicator 	 CAUTION Stop the engine immediately if the red light is ON while the engine is running. The red light will illuminate when the system is not in the OFF state and the oil pressure sensor indicates an insufficient pressure. This includes illuminating at System Power ON until the normal operating minimum is reached. Not on at Start Check. When light illuminates, lift truck will enter Engine Shutdown mode, if equipped with optional powertrain protection. See Operating Procedures section for Engine Shutdown procedures. If truck is not equipped with optional powertrain protection and light is illuminated when engine is running, turn engine OFF immediately and have truck repaired by service technician.

Table 3. Instruments – Warning and Indicator Lights (See Figure 7) (Continued)

Item No.	Item	Function
13	Warning Light, Engine Coolant Temperature Malfunction Indicator 	<p>⚠ CAUTION Do not continue to operate the lift truck if the light is on during operation.</p> <p>If this red light illuminates while the engine is running, it indicates the engine coolant temperature has reached 110 °C (230 °F) or above.</p> <p>When light illuminates, lift truck will enter Engine Shutdown mode, if equipped with optional powertrain protection. See Operating Procedures section for Engine Shutdown procedures. If truck is not equipped with optional powertrain protection and light is illuminated when engine is running, turn engine OFF immediately and have truck repaired by service technician.</p>

Table 3. Instruments – Warning and Indicator Lights (See Figure 7) (Continued)

Item No.	Item	Function
14	Warning Light, Coolant Level in Radiator Malfunction Indicator 	<p>⚠ CAUTION Do not continue to operate the lift truck if the light is on during operation.</p> <p>If the lift truck is equipped with the premium monitoring package, this red warning light will illuminate when the radiator coolant level switch indicates that the level of coolant in the radiator is too low.</p> <p>When light illuminates, lift truck will enter Engine Shutdown mode, if equipped with optional powertrain protection. See Operating Procedures section for Engine Shutdown procedures. If truck not equipped with optional powertrain protection and light is illuminated when engine is running, turn engine OFF immediately and check coolant level. If coolant level is satisfactory, have truck repaired by service technician.</p>

Table 3. Instruments – Warning and Indicator Lights (See Figure 7) (Continued)



Item No.	Item	Function
15	Warning Light, Fuel Level Indicator 	<p>⚠ CAUTION Do not allow the lift truck to run out of LPG. Damage to the catalytic converter can result.</p> <p>NOTE: For LPG trucks, see label on dash to identify how your truck is equipped. This red indicator light will illuminate when the fuel level is low.</p> <p>For gasoline and diesel trucks: The light first illuminates when there is 1/16th of fuel left in the tank.</p> <p>For LPG Trucks with LPG pressure switch: The light illuminates when there is 30 seconds to 3 minutes of operation remaining.</p> <p>For LPG trucks equipped with the Premium Low Fuel Sensor: The light illuminates when there is 10 to 20 minutes of operation remaining. An audible alarm will sound every 4 minutes when the red light is illuminated.</p>
16	Indicator Light Cold Start (Diesel Only) 	<p>This amber indicator light will illuminate for up to 10 seconds after engine startup signifying that the glow plugs are functioning properly at temperatures up to 80 °C (176 °F) coolant temperature.</p>

Table 3. Instruments – Warning and Indicator Lights (See Figure 7) (Continued)

Item No.	Item	Function
17	Indicator Light Water Separator (Diesel Only) 	This amber indicator light will illuminate if the fuel-water separator sensor indicates that water must be drained. Not on at Start Check.

Operator Controls

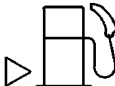
(See Table 4 and Figure 8)

 WARNING

If any of the controls, instruments, levers, or pedals do not operate as described in the following tables, report the problem immediately. **DO NOT** operate the vehicle until the problem is corrected.

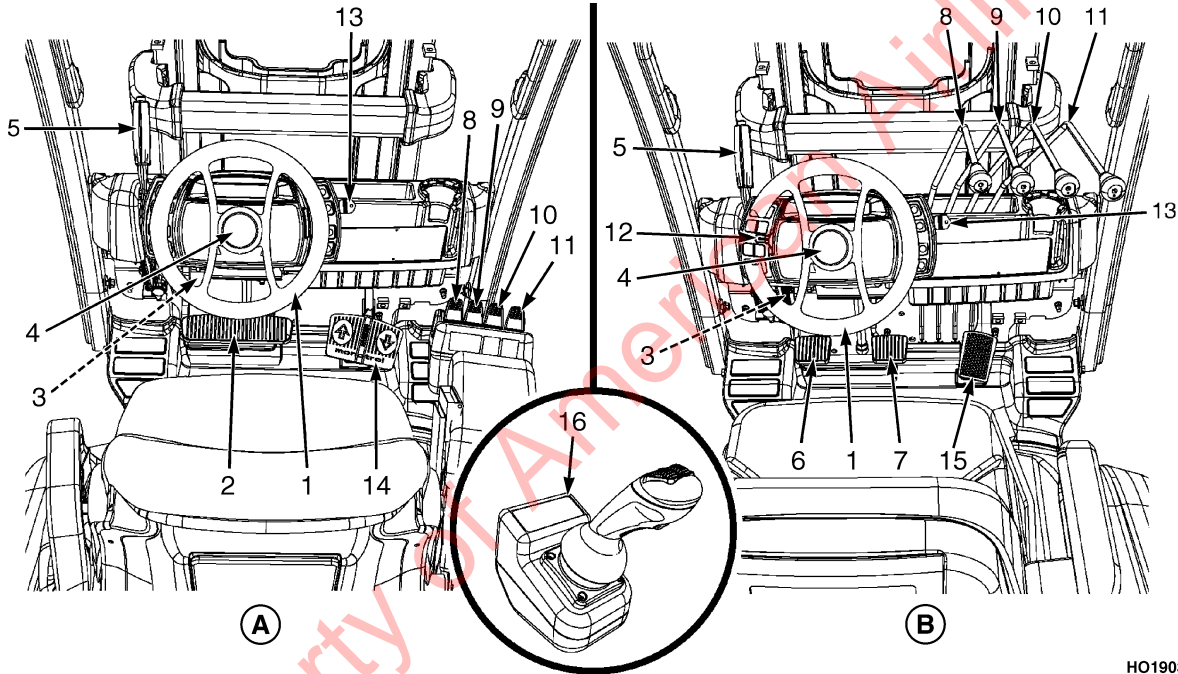

HO190388

SEE FIGURE 9 FOR MORE OPERATOR COMPARTMENT PEDAL CONFIGURATIONS.

Figure 8. Operator Controls (Sheet 1 of 2)

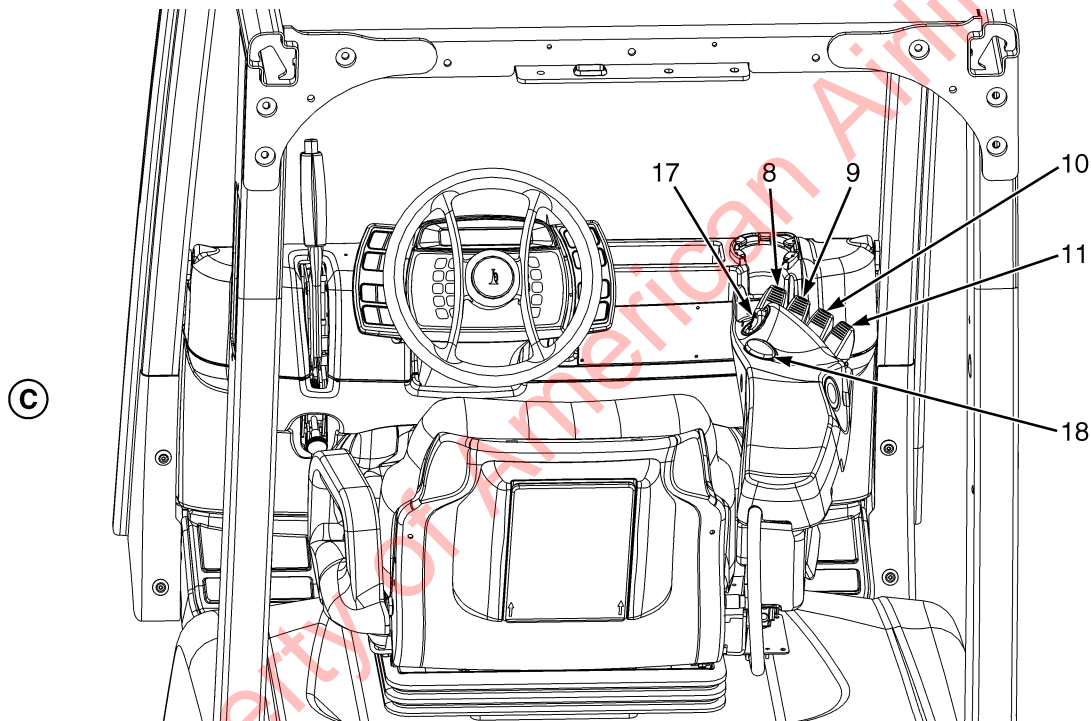

Figure 8. Operator Controls (Sheet 2 of 2)

BO190676

Model Description

HYSTER

Legend for Figure 8

- A. UNITS WITH MONOTROL® PEDAL
- B. UNITS WITH DIRECTION CONTROL LEVER
- C. UNITS BUILT AFTER JANUARY, 2010 WITH E-HYDRAULICS.

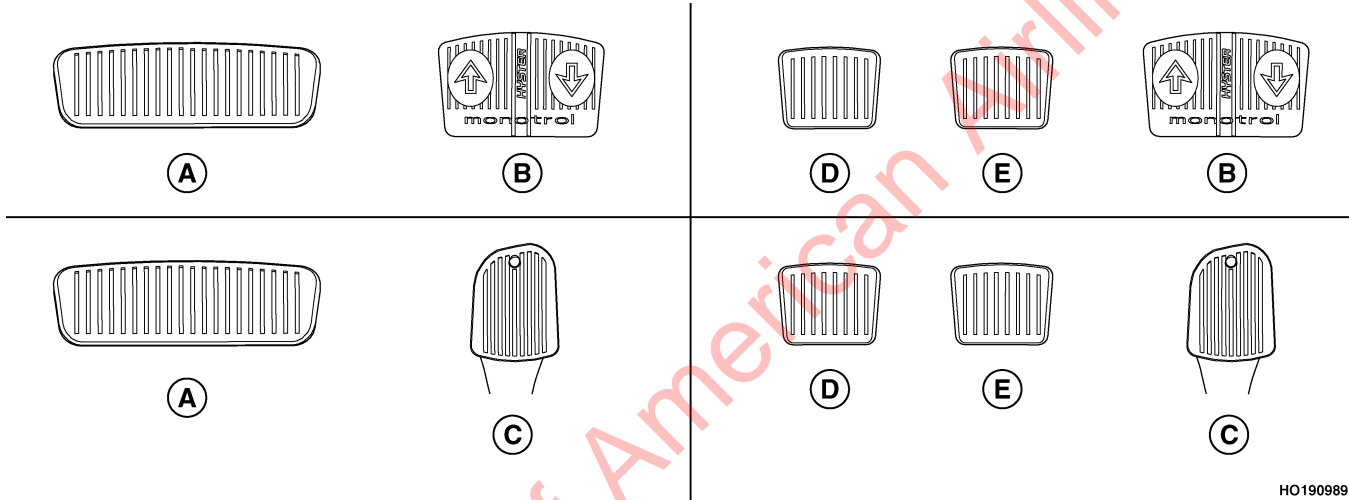

HO190989

- A. INCHING/BRAKE PEDAL
- B. PEDAL
- C. ACCELERATOR PEDAL

- D. INCHING/BRAKE PEDAL
- E. BRAKE PEDAL

Figure 9. Operator Compartment Pedal Configurations

Table 4. Operator Controls (See Figure 8)

Item No.	Item	Function
1	Steering Wheel	The steering wheel controls the position of the steer tires.
2	Inching/Brake Pedal 	By varying the position of the inching/brake pedal, the operator can move the lift truck slowly while a high engine speed is used for lifting loads. Completely depressing the pedal disengages the transmission and applies the service brakes. The brake lights will be on when the brake pedal is depressed during normal operation. On units with a pedal, the engine can be started when the inching/brake pedal is fully depressed or when the parking brake is applied.

Table 4. Operator Controls (See Figure 8) (Continued)



Item No.	Item	Function
3	Lever For Steering Column Tilt 	To move the steering column up, pull up on the tilt lever and the steering column moves up. Release the lever when the steering column reaches the desired position. To move the steering column down, grab the steering wheel and pull up on the lever. Pull the steering column to the desired position.
4	Horn 	The horn button controls the operation of the horn.

Table 4. Operator Controls (See Figure 8) (Continued)

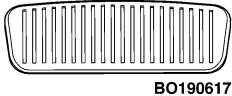
Item No.	Item	Function
5	Parking Brake Lever 	<p>⚠ WARNING Correct adjustment is necessary to provide adequate braking. See the Maintenance section for adjustment procedures.</p> <p>Always apply the parking brake when leaving the lift truck.</p> <p>NOTE: There is a sensor in the seat that actuates an audible alarm. If the operator leaves the seat, with either system power ON or OFF, without applying the parking brake, the alarm will sound for 10 seconds.</p> <p>The lift truck is equipped with a lever to apply the parking brake. Pull the lever to apply the parking brake. Use your thumb to release the button on the lever when the lever is moved to release the parking brake.</p> <p>On units with a pedal, applying the parking brake puts the transmission in NEUTRAL. The parking brake must be fully applied for the grade or surface conditions when operator leaves the lift truck. The lift truck can be started with the park brake applied.</p>

Table 4. Operator Controls (See Figure 8) (Continued)

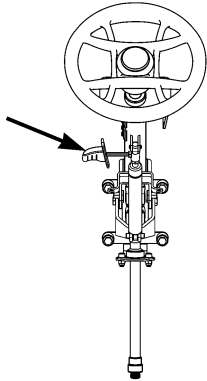
Item No.	Item	Function
6	Inching/Brake Pedal  BO190632	By varying the position of the inching/brake pedal, the operator can move the lift truck slowly while a high engine speed is used for lifting loads. Completely depressing the pedal disengages the transmission and applies the service brakes. The engine can be started when the inching/brake pedal is fully depressed and Direction Control Lever is in neutral.
7	Brake Pedal  BO190632	This pedal, controlled by the operator's right foot, controls the application of the service brakes.

Table 4. Operator Controls (See Figure 8) (Continued)

Item No.	Item	Function
8	<p>Lift/Lower Control Lever</p>  <p>LIFT</p>  <p>FR LIFT</p> <p>BO190623</p>	<p>NOTE: Manual hydraulic control levers are standard on the trucks covered in this manual (see Figure 8). Two optional controls are available for the hydraulic functions: electronic hydraulic mini-levers (see Figure 8) and a joystick (see Figure 10 and Table 5).</p> <p>NOTE: To operate the mini-levers, the operator must be on the seat and the arm rest must be in the down position.</p> <p>The lift/lower control lever can be either the first manual lever or first mini-lever to the right of the operator's seat. Pull backward toward the operator to raise the carriage and forks. Push forward to lower the carriage and forks.</p>

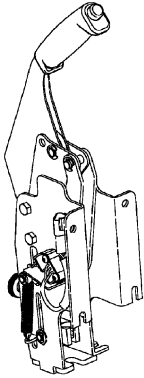
Table 4. Operator Controls (See Figure 8) (Continued)

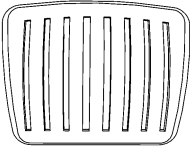
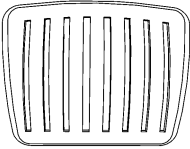

Item No.	Item	Function
9	<p>Tilt Control Lever</p>  <p>TILT</p>  <p>RTST BO190624</p>	<p>NOTE: Manual hydraulic control levers are standard on the trucks covered in this manual (see Figure 8). Two optional controls are available for the hydraulic functions: electronic hydraulic mini-levers (see Figure 8) and a joystick (see Figure 10 and Table 5).</p> <p>NOTE: To operate the mini-levers, the operator must be positioned in the seat and the arm rest must be in the down position.</p> <p>The tilt control lever can be either the second manual lever or second mini-lever to the right of the operator's seat. Push the lever forward to tilt the mast and forks forward. Pull the lever backward toward the operator to tilt the mast and forks backward.</p>

Table 4. Operator Controls (See Figure 8) (Continued)

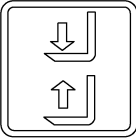
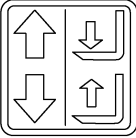

Item No.	Item	Function
9 (Cont)	Tilt Control Lever  TILT  RTST BO190624	<p>These trucks can be equipped with the Return to Set Tilt (RTST) option if truck has electronic hydraulic mini-levers. The RTST option automatically stops the tilt function at a set point. To override the RTST option, press the override button located directly behind the tilt mini-lever and push the tilt mini-lever forward or pull backward.</p> <p>RTST is intended as an operator aid in positioning forks or attachments for their application to minimize product damage and facilitate load handling. Care should be taken to operate the truck in accordance with load handling instructions as described in Operating Techniques in the Operating Procedures section of this Operating Manual.</p>

Table 4. Operator Controls (See Figure 8) (Continued)

Item No.	Item	Function
10	<p>Manual Control Lever for Auxiliary Hydraulic Functions (3rd lever). See Figure 8.</p> 	<p>⚠ WARNING A manual control lever with a detent must be installed when an attachment with a clamp is installed. See your dealer for lift trucks to get the correct control lever.</p> <p>NOTE: Manual hydraulic control levers are standard on the trucks covered in this manual (see Figure 8). Two optional controls are available for the hydraulic functions: electronic hydraulic mini-levers (see Figure 8) and a joystick (see Figure 10 and Table 5).</p> <p>The third manual control lever is installed to the right of the manual tilt control lever. This lever can have two methods of operation, depending on the attachment.</p> <p>NOTE: If truck is equipped with only three levers and clamp attachment, the last (3rd) lever controls clamp functions.</p> <p>Control Lever with a Detent - Attachments with a clamp action: The lever is spring-loaded toward the operator. The lever is operated by moving it to the right, then forward and back.</p> <p>Control Lever without a Detent - Attachments without a clamp action: The lever is operated by moving it forward and back.</p>

Table 4. Operator Controls (See Figure 8) (Continued)

Item No.	Item	Function
10	<p>Electronic Control Mini-Lever for Auxiliary Hydraulic Functions (3rd lever). See Figure 8.</p>  <p>BO210023</p> <p>1. OVERRIDE BUTTON</p>	<p>The third electronic control mini-lever is installed to the right of the electronic tilt control lever. This lever can have two methods of operation, depending on the attachment.</p> <p>NOTE: To operate the mini-levers, the operator must be on the seat and the arm rest must be in the down position.</p> <p>NOTE: If truck is equipped with only three levers and clamp attachment, the last (3rd) lever controls clamp functions.</p> <p>Trucks with Clamp Attachment: To engage the clamp, move the mini-lever backward. To disengage the clamp, press the override button located directly behind the mini-lever and push the mini-lever forward.</p> <p>Trucks without Clamp Attachment: The lever is operated by moving it forward and back. The lever is spring-loaded to return to the neutral position when released.</p>

Table 4. Operator Controls (See Figure 8) (Continued)

Item No.	Item	Function
11	<p>Manual Control Lever for Auxiliary Hydraulic Functions (4th lever). See Figure 8.</p> 	<p>NOTE: Manual hydraulic control levers are standard on the trucks covered in this manual (see Figure 8). Two optional controls are available for the hydraulic functions: electronic hydraulic mini-levers (see Figure 8) and a joystick (see Figure 10 and Table 5).</p> <p>The fourth manual control lever is installed to the right of the third manual control lever. This lever can have two methods of operation, depending on the attachment.</p> <p>NOTE: If truck is equipped with four levers and clamp attachment, the last (4th) lever controls clamp functions.</p> <p>Control Lever with a Detent - Attachments with a clamp action: The lever is spring-loaded toward the operator. The lever is operated by moving it to the right, then forward and back.</p> <p>Control Lever without a Detent - Attachments without a clamp action: The lever is operated by moving it forward and back.</p>

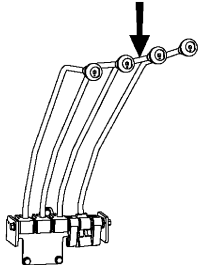
Table 4. Operator Controls (See Figure 8) (Continued)

Item No.	Item	Function
11	<p>Electronic Control Mini-Lever for Auxiliary Hydraulic Functions (4th lever). See Figure 8.</p>  <p style="text-align: center;">BO210024</p> <p>1. OVERRIDE BUTTON</p>	<p>The fourth electronic control lever is installed to the right of the third electronic control lever. This lever can have two methods of operation, depending on the attachment.</p> <p>NOTE: To operate the mini-levers, the operator must be on the seat and the arm rest must be in the down position.</p> <p>NOTE: If truck is equipped with four levers and clamp attachment, the last (4th) lever controls clamp functions.</p> <p>Trucks with Clamp Attachment: To engage the clamp, move the mini-lever backward. To disengage the clamp, press the override button located directly behind the mini-lever and push the mini-lever forward.</p> <p>Trucks without Clamp Attachment: The lever is operated by moving it forward and back. The lever is spring-loaded to return to the neutral position when released.</p>

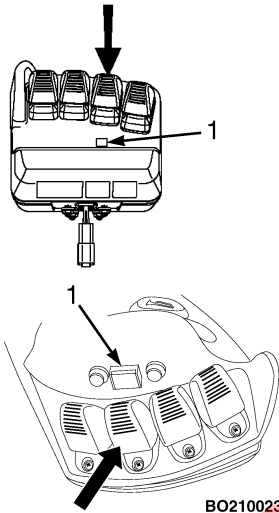
Table 4. Operator Controls (See Figure 8) (Continued)

Item No.	Item	Function
12	Direction Control Lever 	<p>NOTE: There is a sensor in the seat that actuates an audible buzzer. If the operator leaves the seat with the key switch ON and the lever is not in NEUTRAL, the buzzer will pulse ON and OFF for 10 seconds.</p> <p>The Direction Control Lever for the transmission is on the left side of the Display Switch Cluster. The Direction Control Lever is used on lift trucks without a pedal. The Direction Control Lever has three positions that are indicated by three green lights on left side of Display Switch Cluster (see Figure 7 and Table 3): FORWARD, NEUTRAL (N), and REVERSE. Move the lever to one of the direction positions for travel. The Direction Control Lever must be in the NEUTRAL (N) position before the engine can be started. The reverse lights will be on and, if equipped, reverse alarm will be activated when the lever is placed in the REVERSE position.</p>

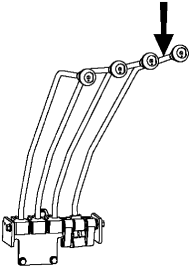
Table 4. Operator Controls (See Figure 8) (Continued)

Item No.	Item	Function
13	Key Switch  BO190097	<p>NOTE: There is no mechanical lockout that prevents the key switch from being returned to the START position without first being returned to the OFF position. However, the Vehicle System Manager (VSM) software prevents the starter motor from being energized while the engine is running.</p> <p>The key switch is located on the right side of the Display Switch Cluster. The key switch has three positions:</p> <p>No. 1 Position: OFF position. De-energizes all electric circuits except for the horn and front and rear work lights.</p> <p>No. 2 Position: ON position. Energizes all electric circuits except the starter circuit. The key switch will be in this position during normal operation.</p> <p>No. 3 Position: START position. Energizes the starter motor for starting the engine. A spring returns the key to position No. 2 (ON position) when the key is released.</p>
14	MONOTROL® Pedal  BO210020	<p>The pedal controls the speed and direction of the lift truck. Pushing on the right side of the pedal causes the lift truck to move in reverse. Pushing on the left side of the pedal causes the lift truck to move in forward. The speed of the engine increases as the pedal is depressed. The reverse lights and the optional reverse alarm will be on in the reverse position during normal operation.</p>

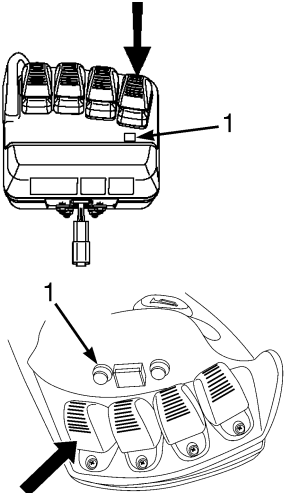
Table 4. Operator Controls (See Figure 8) (Continued)

Item No.	Item	Function
15	Accelerator Pedal  BO190098	This pedal controls the speed of the engine and is operated by the operator's right foot. It is used on units that have a Direction Control Lever.
16	Joystick 	The lift trucks in this manual can be equipped with an optional joystick to control the hydraulic functions. See Figure 10 and Table 5 for a description of the joystick features.
17	Direction Control Switch  BO210026	The Direction Control Switch for the transmission is next to the auxiliary horn button on the armrest. The Direction Control Switch is used on lift trucks without a MONOTROL® pedal.

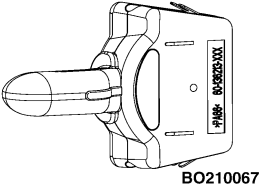
Table 4. Operator Controls (See Figure 8) (Continued)

Item No.	Item	Function
18	Auxiliary Horn Button  <p style="text-align: right; margin-right: 50px;">BO210025</p>	Auxiliary horn button functions when the key or keyless ignition is in the ON position and up to 20 minutes after the key or keyless ignition is turned to the OFF position.
	Battery Disconnect Switch (Not Shown In Figure 8) 	This switch is only on units with the GS or LPS fire safety rating. The operator can shut off all electrical power to the lift truck by pulling up on the T-handle that is located between the steering wheel and the parking brake.

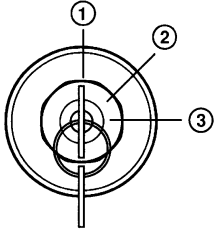
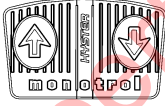
Operator Controls – Joystick Features (See Table 5 and Figure 10)

⚠ WARNING

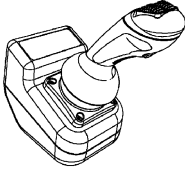
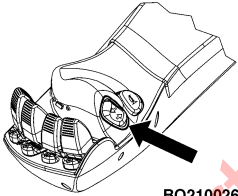
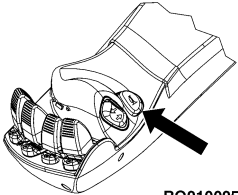
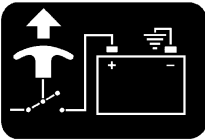
If any of the controls, instruments, levers, or pedals do not operate as described in the following tables, report the problem immediately. DO NOT operate the vehicle until the problem is corrected.

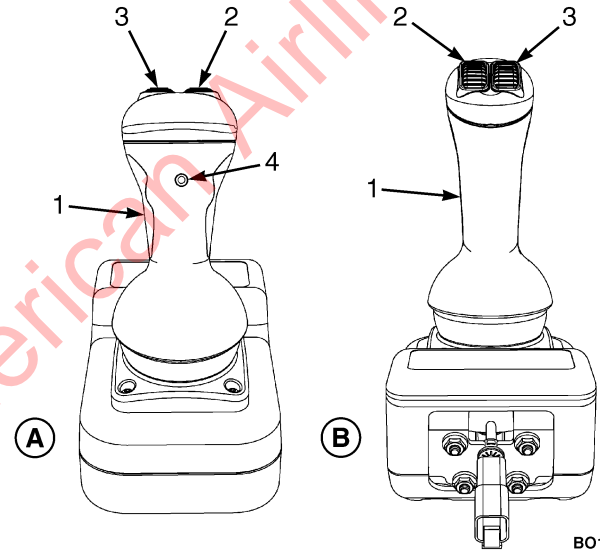

BO190062

A. FRONT VIEW

B. REAR VIEW

Figure 10. Joystick

Table 5. Operator Controls – Joystick Features (See Figure 10)

Item No.	Item	Function
1	Lift/Lower Function A. Lower B. Lift	<p>NOTE: To operate the joystick, the operator must be on the seat.</p> <p>Push the joystick lever forward to lower the carriage and forks. Pull the joystick lever rearward to raise the carriage and forks.</p>

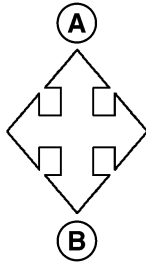

Table 5. Operator Controls – Joystick Features (See Figure 10) (Continued)

Item No.	Item	Function
1	<p>Tilt Function</p>  <p>A. Backward B. Forward</p>	<p>NOTE: To operate the joystick, the operator must be on the seat.</p> <p>Move the joystick lever to the left to tilt the mast backward.</p> <p>Move the joystick lever to the right to tilt the mast forward.</p> <p>NOTE: If lift trucks are equipped with clamp attachment option, Return to Set Tilt (RTST) is not available.</p> <p>These trucks can be equipped with the Return to Set Tilt (RTST) option. The RTST option automatically stops the tilt function at a set point. To override the RTST option, press the override button located directly in front of the joystick and push the joystick left or right.</p> <p>RTST is intended as an operator aid in positioning forks or attachments for their application to minimize product damage and facilitate load handling.</p> <p>Care should be taken to operate the lift truck in accordance with load handling instructions as described in Operating Techniques in the Operating Procedures section of this Operating Manual.</p>

Table 5. Operator Controls – Joystick Features (See Figure 10) (Continued)

Item No.	Item	Function
2, 4	Auxiliary Hydraulic Function (Left Rocker Switch) 	<p>This rocker switch will control either Function 3 or Functions 3 and 4, depending on the attachment.</p> <p>NOTE: To operate the joystick, the operator must be on the seat.</p> <p>NOTE: If the lift truck is equipped with only a three function valve and clamp attachment, the left rocker switch controls the clamp functions.</p> <p>Trucks with clamp attachments: To engage the clamp, move the left rocker switch forward to clamp. To disengage the clamp, push and release the override button located directly in front of the joystick and pull the left rocker switch to the rear.</p> <p>Trucks without clamp attachment: The left rocker switch is operated by moving it forward and back. The rocker switch is spring loaded to return to the neutral position when released.</p>

Table 5. Operator Controls – Joystick Features (See Figure 10) (Continued)



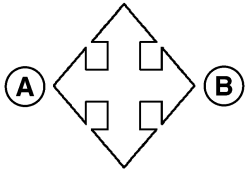



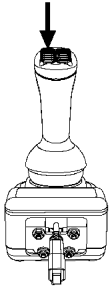

Item No.	Item	Function
3, 4	Auxiliary Hydraulic Function (Right Rocker Switch) 	<p>This rocker switch will control either Function 4 or Functions 4 and 5, depending on the attachment.</p> <p>NOTE: To operate the joystick, the operator must be on the seat.</p> <p>NOTE: If the truck is equipped with only a four function valve and clamp attachment, the right rocker switch controls the clamp functions.</p> <p>Trucks with clamp attachments: To engage the clamp, move the right rocker switch forward to clamp. To disengage the clamp, push and release the override button located directly in front of the joystick and pull the right rocker switch to the rear.</p> <p>Trucks without clamp attachment: The right rocker switch is operated by moving it forward and back. The rocker switch is spring loaded to return to the neutral position when released.</p>

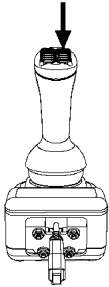
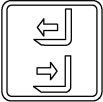
Table 6. Auxiliary Control Levers

Function	Direction of Movement	
	Load or Equipment	Control Lever
1. REACH	Retract/Extend	Backward/Forward
2. SIDESHIFT	Right/Left	Backward/Forward
3. PUSH-PULL	Backward/Forward	Backward/Forward
4. ROTATE	Clockwise/Counterclockwise	Backward/Forward
5. UPENDER	Up/Down	Backward/Forward
6. SCOOP	Up/Down	Backward/Forward
7. LOAD STABILIZER	Down (Clamp)/Up (Release)	Backward/Forward
8. SWING (FORKS)	Right/Left	Backward/Forward
9. FORK SPREAD	Together/Apart	Backward/Forward
10. CLAMP	Clamp/Release	Backward/Forward

1	2	3	4	5	6	7	8	9	10
									

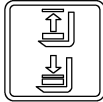
BO190744

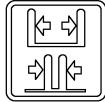
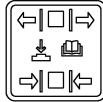
Operating Procedures

General

Know Your Lift Truck

WARNING

Always make sure the parking brake is fully applied before leaving the lift truck. If the operator leaves the lift truck without applying the parking brake, a seat activated switch will shift the transmission to neutral, and sound an alarm for 10 seconds. If the lift truck is left on a grade, without the parking brake fully applied, the lift truck will free-wheel down the grade, possibly causing injury or property damage.

WARNING **EXHAUST GASES**

Exhaust from internal combustion engines contains carbon monoxide and other harmful chemicals. Carbon monoxide is a colorless, odorless poison and can cause unconsciousness or death without warning. Long-term exposure to exhaust or chemicals in the exhaust can cause cancer, birth defects, and other reproductive harm. Avoid exposure to engine exhaust.

If engines are operated in confined spaces, maintain adequate ventilation or vent exhaust to the outside. Do not exceed applicable air contaminant limits (see 29 CFR 1910.1000 Table Z-1).

Follow the inspection and maintenance schedule and procedures in this manual. Do not alter exhaust, ignition, or fuel systems.

WARNING **FIRE HAZARD**

The hot engine surfaces and exhaust of internal combustion engine powered lift trucks can present fire hazards when operating in areas containing flammable gases, vapors, liquids, dusts, fibers, or paper debris. Engine and exhaust component surface temperatures can exceed the ignition temperatures of common solvents, fuels, oil, paper, and other organic materials (wood, wheat, cotton, etc.). Exhaust emitted sparks can ignite these materials as well. Engine and exhaust surface temperatures increase after engine shutoff, presenting increased fire hazard. Check the engine compartment frequently in areas containing

combustible dust, fibers, or paper and remove any foreign materials. Contact your local dealer for forklift modifications that may be appropriate in environments with fire hazards.

Operate the lift truck only in areas that have been approved for lift truck operation.

- OSHA regulations prohibit the use of lift trucks in areas containing hazardous concentrations of certain flammable gases or vapors.
- OSHA regulations require operating areas to be classified as hazardous or nonhazardous, and that the lift trucks used in designated locations be of the minimum type specified (see *Guide For Users Of Industrial Trucks*, Appendix C and Table N-1).

Only the designated types of approved lift trucks may be used in areas classified as hazardous by the authority having jurisdiction. Areas classified as hazardous must be identified by signs to show the type of approved lift truck required for operation in the area. Modifications or poor maintenance can result in the lift truck being unsuitable for operation in areas classified as hazardous.

The fork lift truck is designed to pickup, move, and tier materials. The basic lift truck has a lift mechanism and forks on the front to engage the load. The lift mechanism lifts the load so that it can be moved and stacked.

In order to understand how the fork lift truck can pick up a load, you must first know some basic things about the lift truck.

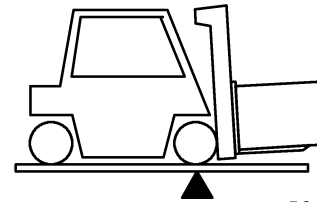

BO190107

The lift truck is based on the principle of two weights balanced on opposite sides of a pivot (fulcrum). This is the same principle used for a see-saw. In order for this principle to work for a lift truck, the load on the forks must be balanced by the weight of the lift truck. The location of the center of gravity of both the truck and the load is also a factor.

This basic principle is used for picking up a load. The ability of the lift truck to handle a load is discussed in terms of center of gravity and both forward and side stability.

Stability and Center of Gravity

The center of gravity (CG) of any object is the single point about which the object is balanced in all directions.

Every object has a CG. When the lift truck picks up a load, the truck and load have a new combined CG.

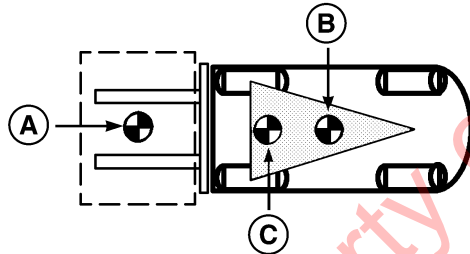
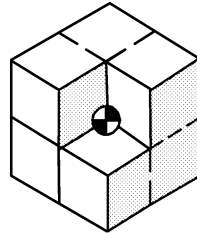

A. CG LOAD B. CG TRUCK C. COMBINED CG

The stability of the lift truck is determined by the location of its CG, or if the truck is loaded, the combined CG.

The lift truck has moving parts and therefore has a CG that moves. The CG moves forward and back as the mast is tilted forward and back. The CG moves up and down as the mast moves up and down.

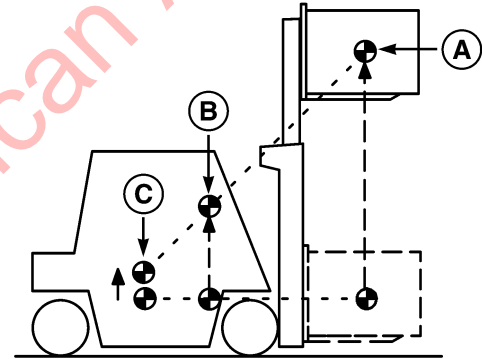

A. CG LOAD B. COMBINED CG C. CG TRUCK

The center of gravity, and therefore the stability of the loaded lift truck, is affected by a number of factors such as size, weight, shape, and position of the load; the height to which the load is raised; the amount of forward and backward tilt; tire pressure and the dynamic forces created when the truck is moving. These dynamic forces are caused by things like acceleration, braking, turning, and

Operating Procedures

HYSTER

operating on uneven surfaces or on an incline. These factors must be considered when traveling with an unloaded truck, as well, because **an unloaded truck will tip over to the side easier** than a loaded truck with its load in the lowered position.

In order for the lift truck to be stable (not tip over forward or to the side), the CG must stay within the area of the lift truck represented by a triangle drawn between the drive axle and the pivot of the steering axle.

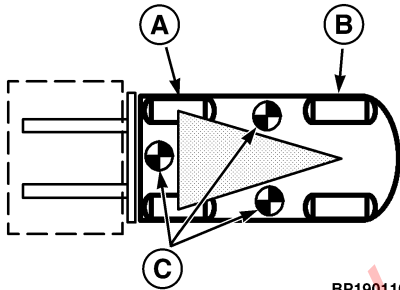

BP190110

A. DRIVE AXLE B. STEERING AXLE C. TRUCK WILL TIP OVER

If the CG moves forward of the drive axle, the lift truck will tip forward. If the CG moves outside of the line represented by the lines drawn between the drive wheels and the steering axle pivot, the lift truck will tip to that side.

Capacity (Weight and Load Center)

The capacity of the lift truck is shown on the Nameplate. The capacity is listed in terms of weight and load center. The weight is specified in kilograms and pounds. The load center is specified in millimeters and inches. The capacity is the maximum load that the lift truck can handle, with the mast vertical, for the load condition shown on the Nameplate.

! WARNING

Trained Operators and Mechanics only

Read Operating Manual located on or near seat.

Failure to follow operating, inspection, and maintenance instructions can cause serious injury or death!

CAPACITY WITH MAST VERTICAL AND EQUIPPED AS SHOWN

HYSTER Lift Truck Model		Serial Number		Sales Order	
Attachment					
Truck Weight	kg (lb)	Back Tilt		Degrees	
Tire Size	Front	Rear			
Pressure					
Tread Width	mm (lb)				
MAXIMUM CAPACITY	Load Height		Load Center		
	Dim. A	Dim. B	Dim. C		
	(kg)	(mm)	(mm)	(mm)	(mm)
	(lb)	(in)	(in)	(in)	(in)

HO190009

The load center of a load is determined by the location of its center of gravity. The load center is measured from the front face of the forks, or the load face of an attachment, to

66

the center of gravity of the load. Both the vertical and horizontal load centers are specified on the Nameplate.

Loads should be transported while centered on the centerline of the lift truck. The operator must know whether or not a load is within the maximum capacity of the lift truck before the load is handled.

Impact Sensor

The lift trucks covered in this **Operating Manual** may be equipped with an optional impact sensor that can be enabled or disabled by a service technician. The impact sensor will sense when the lift truck has hit an object, and will cause the lift truck to shutdown. There are two types of impact that the Vehicle System Manager (VSM) recognizes: soft impact and hard impact.

The data parameters that determine whether an impact is a soft or hard one are entered into the lift truck's VSM by personnel with a service password (see Operator Passwords in this section).

If the impact sensor option is enabled and an impact has been detected, then lift truck will shut down once the Impact Shutdown Timer has expired (range is from 0 to 30 seconds). During this time an alarm will sound and the

Impact Detection icon will be displayed on the LCD screen. If the time is set to 0 seconds, the lift truck will shut down right after the impact is detected and no alarm will sound.

The Impact Shutdown Timer and other Impact related setup parameters can be set by either a service technician or supervisor.

The truck can be configured to completely shut down after an impact, which will include the electro-hydraulic functions. If a load is in the raised position and needs to be lowered, see **Load Handling, Emergency Load Lowering** and **Figure 15**.

Once shutdown, the lift truck cannot move until the impact sensor is reset by a supervisor or service technician. The Impact Detection icon will be displayed on the LCD screen any time the accelerator pedal is depressed (or hydraulic lever is moved, if configured to shut the truck completely down) while the truck is shut down.

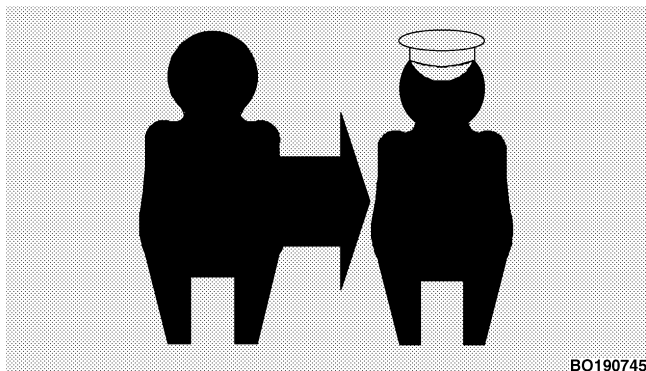

Figure 11. Impact Detected Icon

To clear messages and reset truck to normal operation, and Impact reset must be performed by either a service technician or supervisor. See **User Interface, Supervisor 2200 SRM 1130** or **User Interface, Service 2200 SRM 1131** for procedures.

Inspection Before Operation

WARNING

Report damage or faulty operation immediately. Do not operate a lift truck that needs repair. A lift truck will

only do its job when it is in proper working order. If repairs are required, install a tag in the operator's area stating "DO NOT OPERATE" and remove the key from the key switch if truck is equipped with key switch option.



Checks With the Engine Stopped

Inspect the lift truck before use and every eight hours or daily as described in the **Maintenance** section of this **Operating Manual**. Inspect more frequently if used in severe operating conditions.

Before using the lift truck, make the following checks:

- Condition of forks, carriage, chains, header hoses, mast, attachment, and overhead guard.
- Condition of wheels and tires.
- Seat belt fastens correctly.
- Seat is correctly fastened to its mounts. Hood is correctly latched.
- Condition of the engine compartment. Ensure all surfaces are free of oils, lubricants, fuel, and organic dusts or

fibers (paper, wood, cotton, agricultural grass/grain, etc).
Remove all foreign materials.

- Coolant level in the cooling system and condition of the drive belts.
- Condition of the radiator and screen. Clean if necessary.
- Fuel level.
- Oil level in the engine.
- Oil level in the hydraulic tank.
- Leaks from the engine, transmission, hydraulic system, and fuel system.
- Loose or missing hardware.
- Check transmission oil level.

Mounting and Dismounting

WARNING

To avoid serious injury when entering or exiting the lift truck, ALWAYS USE 3 POINTS OF CONTACT. Maintain contact simultaneously with two hands and one foot or with two feet and one hand while climbing on or off the lift truck.

Place feet carefully. Always face the lift truck when climbing on or off. Use added care when surfaces are slippery. Keep hands free of any obstacles such as food, beverages, or tools.

Operator Passwords

The lift trucks covered in this manual have an optional password feature.

The Operator Passwords are a series of five numbers. Each of the five number digits can be the numbers 1 through 5. If enabled, the password number series must be entered into the memory by a technician and assigned to an operator. Remember the password. A technician can use a personal computer (PC), connected to the vehicle, to check as well as assign the passwords.

There are four password types used on these trucks:

- **Operator:** Allows operator to operate lift truck.
- **Lockout Reset:** Lockout will occur when an operator incorrectly enters their password a specified number of times. After lockout occurs the following message will appear in the display, "Password Lockout" "Supervisor Required." The supervisor will enter the Lockout Reset password to unlock the system.
- **Supervisor:** Has all rights assigned to Operator and Lockout Reset passwords. Can add, edit, and delete Operator or Supervisor passwords and view all truck diagnostic information. Allows access to truck service parameters within preset limits.
- **Service:** Has all rights assigned to Operator, Lockout Reset, and Supervisor passwords. Can add, edit, and delete Operator, Supervisor, and Service passwords and view all truck diagnostic information. Allows access to truck service parameters within preset limits.

If the optional password feature is enabled and after the key is moved to the **ON** position, or the Power **ON/OFF** button is pressed, the LCD screen will show the message **PASSWORD ENTRY**. Use the numbered push buttons

(see **Figure 6** and **Table 2**) to enter the five digit password and then press the STAR (*) button to enter the password and access main menu. If the password is entered incorrectly, and truck is not locked out, the message **PASSWORD INVALID** and **DISABLED IN ###**, with **###** being the number of attempts remaining before lockout occurs. The number of attempts is adjustable and set by a supervisor or service technician.

If the truck is locked out, the message **PASSWORD LOCKOUT, SUPERVISOR REQUIRED** is displayed. A Lockout Reset, Supervisor, or Service password is needed to unlock the lift truck. System power can be turned **OFF**, while in lockout mode by turning key switch to **OFF** or pressing the Power **ON/OFF** button. To reset a system lockout that occurs while attempting to enter a password within the on-board menu, after a correct operator password has been entered, recycle the system power. For all other lockout conditions, cycling the truck power will not reset the lockout.

Starting Procedures

Do not start or operate the lift truck, including any of its functions or attachments, from any place other than the designated operator's position.

If equipped, be sure cab door is secured in the closed position or removed before starting lift truck operations.

If lift truck is equipped with the optional operator presence system, the following sequence must be followed for engine to start:

- Operator must be in seat
- Seat belt must be fastened
- Make sure park brake is applied

Starting Procedures, Trucks With Key Switch

WARNING

LPG is very flammable. An odor of LPG fuel can indicate a leak in the fuel system. **DO NOT** start the engine until the fuel leak is repaired and the atmosphere is free of LPG.

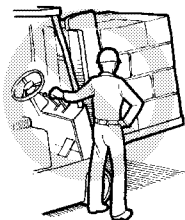

BO190112

WARNING

Gasoline is extremely flammable. Do not start the engine if a gas leak is detected.

NOTE: Lift trucks equipped with Mazda 2007 emission compliant engines have a "Clear Flood Mode" programmed into the ECU. When the accelerator is depressed more than 80% during cranking, the ECU will not allow any fuel into the gasoline or LPG engines. This allows the engine to clear any excess fuel out of the intake manifold and cylinders.

1. If the lift truck uses LPG fuel, open the fuel valve on the LPG tank.

NOTE: If the ambient temperature is below freezing [0°C (32°F)], perform **Step 2** through **Step 6** below for lift trucks equipped with Mazda LPG engine (except Mazda 2007 emission compliant engines).

NOTE: The warm-up/thaw cycle can be bypassed at any-time by cranking the engine normally.

2. Turn/push the key switch to the **ON** position but **do not** crank the engine.

3. The Engine Control Unit (ECU) will automatically begin a warm-up/thaw cycle which preheats select fuel system components.
4. Do not attempt to start the engine for approximately 1 minute.
5. Start the engine using the cranking key position. Use of the accelerator pedal may assist in starting and keeping the engine running, until warmed.
6. If engine fails to start, turn the key to the **OFF** position for at least 30 seconds, then repeat procedure insuring that 1 minute delay has been observed.
7. Make sure the parking brake is applied or push on the inching/brake pedal.
8. If equipped, put the direction control lever for the transmission in the **NEUTRAL (N)** position.
9. Make sure lift truck hood is closed.
10. Turn the key to the **ON** position. If lift truck is equipped with a diesel engine and engine is cold, the cold start indicator light will illuminate and the cold start circuit will be energized.

11. If the truck is equipped with Operator Password feature, enter correct operator, supervisor, or service password.

12. On trucks equipped with a LPG or gasoline engine, turn the key to the **START** position to engage the starter. The word "Cranking" and a 30-second countdown timer will appear on the LCD screen when the key is in the **START** position.

On lift trucks equipped with a diesel engine, if cold start delay is required, the cold start indicator will be illuminated and a countdown time of ten seconds is displayed. When countdown reaches 0, turn the key to the **START** position to engage the starter.

For all engine types, if engine fails to start after 30 seconds, the starter will shutdown for 60 seconds to cool off. A 60-second countdown timer will appear on the LCD screen showing the time remaining before a restart attempt can be tried. To restart engine, repeat **Step 10** through **Step 12**.

Starting Procedures, Trucks With Keyless Start Option

WARNING

LPG is very flammable. An odor of LPG fuel can indicate a leak in the fuel system. **DO NOT** start the engine until the fuel leak is repaired and the atmosphere is free of LPG.

WARNING

Gasoline is extremely flammable. Do not start the engine if a gas leak is detected.

NOTE: Lift trucks equipped with Mazda 2007 emission compliant engines have a "Clear Flood Mode" programmed into the ECU. When the accelerator is depressed more than 80% during cranking, the ECU will not allow any fuel into the gasoline or LPG engines. This allows the engine to clear any excess fuel out of the intake manifold and cylinders.

1. If the lift truck uses LPG fuel, open the fuel valve on the LPG tank.

NOTE: If the ambient temperature is below freezing [0 °C (32 °F)], perform **Step 2** through **Step 6** below for lift trucks

equipped with Mazda LPG engine (except Mazda 2007 emission compliant engines).

NOTE: The warm-up/thaw cycle can be bypassed at any-time by cranking the engine normally.

2. Turn/push the key button to the **ON** position but do not crank the engine.
3. The Engine Control Unit (ECU) will automatically begin a warm-up/thaw cycle which preheats select fuel system components.
4. Do not attempt to start the engine for approximately 1 minute.
5. Start the engine using the cranking key button. Use of the accelerator pedal may assist in starting and keeping the engine running, until warmed.
6. If engine fails to start, turn the key to the **OFF** position for at least 30 seconds, then repeat procedure insuring that 1 minute delay has been observed.
7. Make sure the parking brake is applied or push on the inching/brake pedal.
8. If equipped, put the direction control lever for the transmission in the **NEUTRAL (N)** position.

9. Make sure lift truck hood is closed.

10. Depress and release the Power **ON/OFF** button. If lift truck is equipped with a diesel engine and engine is cold, the cold start indicator light will illuminate and the cold start circuit will be energized.

11. If the truck is equipped with Operator Password feature, enter correct operator, supervisor, or service password.

12. On trucks equipped with a LPG or gasoline engine, press and hold the Engine Start button to engage the starter. The word "Cranking" and a 30-second countdown timer will appear on the LCD screen when the Engine Start button is pressed.

On trucks equipped with a diesel engine, if cold start delay is required, the cold start indicator will be illuminated and a countdown time of ten seconds is displayed. When countdown reaches 0, press and hold the Engine Start button to engage the starter.

For all engine types, if engine fails to start after 30 seconds, the starter will shutdown for 60 seconds to cool off. A 60-second countdown timer will appear on the LCD screen showing the time remaining before a restart attempt can be tried. To restart engine, repeat **Step 10** through **Step 12**.



Checks With the Engine Running



YO190134

WARNING **FASTEN SEAT BELT** **If Lift Truck Tips Over**

- Do Not Jump – Stay On Truck
- Hold Firmly To Steering Wheel – Brace Feet – Lean Forward And Away From Impact

The seat belt is installed to help the operator stay on the truck if the lift truck tips over. IT CAN ONLY HELP IF IT IS FASTENED.

The operator must be aware that the lift truck can tip over. There is a great risk that the operator or someone else can be killed or injured if trapped or hit by the truck as it tips over. The risk of injury can be reduced if the operator

stays on the truck. **If the truck tips over, do not jump off!**

THE SEAT BELT AND HIP RESTRAINT bracket provides a means to help the operator keep the head and torso substantially within the confines of the truck frame and

overhead guard if a tipover occurs. This protection system is intended to reduce the risk of the head and torso being trapped between the truck and the ground, but it can not protect the operator against all possible injury in a tipover.

Make sure that the area around the lift truck is clear before starting the engine or making any operational checks. Be careful when making the checks. If the lift truck is stationary during a check, apply the parking brake and make sure the direction control is in **NEUTRAL**. Proceed carefully.

Check the operation of the following functions as described in the **Maintenance** section:

- Check the operation of the horn, gauges, and indicator lights.
- Operate the **LIFT**, **TILT**, and auxiliary functions to check for correct operation of the mast, carriage, and attachments.
- Check the operation of the MONOTROL® pedal or the optional direction control lever and accelerator pedal.
- Check the operation of the service brakes and parking brake.
- Check the operation of the steering system.

- Check the oil level in the powershift transmission when the oil is at operating temperature 50 °C (120 °F). Turn the truck off and wait one minute. Then check the transmission oil level.

Load Weighing Sensor

If your lift truck is equipped with the optional load weight sensor, it can display the weight of the load in either pounds or kilograms on the LCD screen (see **Figure 7**). The unit of measure is preset by a service technician and can be changed by a service technician.

The operator can access the load weight function by pressing the up or down arrow keys on the Display Switch Cluster (see **Figure 6**), until the word "Weight" appears on the LCD screen. See **Figure 7**.

To most accurately weigh a load, follow these instructions:

1. With a load on the forks, position the mast in a vertical position.
2. Lift the load 0.6 m (2 ft) off the ground, but if freelif cylinder is present, not more than maximum freelif.

3. Lower the load 51 mm (2 in.). Stop lowering, wait 1 second, and read the load weight. This will be the most accurate weight. Waiting longer to read the load weight will reduce accuracy.

Set Load Weight to Zero

The service technician or supervisor can set the load weight to zero, when the no-load weight displayed on the LCD screen (see **Figure 7**) is not within $\pm 2\%$ of truck capacity. See **User Interface - Supervisor 2200 SRM 1130** or **User Interface - Service Technician 2200 SRM 1131** for procedures.

Engine Shutdown

NOTE: The information in this section pertains to lift trucks with the powertrain protection option. On trucks without powertrain protection, the fault number is displayed on the LCD screen and the Engine Malfunction icon will illuminate, but engine will not shutdown and truck performance will be decreased. **DO NOT continue to run lift truck. Turn engine OFF and notify service technician immediately for repair.**

Certain faults or sensor measurements can cause the truck to go into Engine Shutdown mode. The following actions occur when truck is in this mode:

The VSM will have a coolant over-temperature light come on at 110 °C (230 °F). At 110 °C (230 °F), the engine will be limited to 75% power. A linear power regression will be applied between 110 and 116 °C (230 and 240 °F). At 116 °C (240 °F), the engine will be limited to 50% power.

If vehicle is equipped with an optional power train protection, at 116 °C (240 °F) and at the end of the 30-second countdown, all power to the lift truck is turned off. After shutdown has occurred, recycle power to **ON**, load can then be lowered without starting the engine.



CAUTION

If lift truck experiences an engine shutdown, call a service technician immediately. Continued operation of lift truck after engine shutdown can cause damage to the lift truck and its components.

To restart the lift truck, turn the key switch **OFF** and **ON** again to cycle the system power. If lift truck is equipped with the Power **ON/OFF** button, press Power **ON/OFF** button twice to cycle the system power and then press the

Engine Start button. If the Engine Start button is pressed before the Power **ON/OFF** button, the starter will not operate. See **Starting Procedures, Trucks With Keyless Start Option** in this section, if starter becomes disabled.

When the lift truck has been restarted, it will run for 30 seconds before shutting down again. Cycle the truck power again to run the lift truck for another 30 seconds. This process provides enough power for the lift truck to move under its own power so that it can be moved to a safe location.

Some faults or sensor measurements will not always cause the engine to shutdown, but will cause the speed of the lift truck to be restricted, or will either disable or restrict the truck's hydraulic functions.

When this occurs, the following actions take place:

- The fault number is displayed on the top line of the LCD screen and a description of truck performance being decreased is shown on bottom line.
- The Engine Malfunction icon illuminates (see **Figure 7** and **Table 3**).
- An alarm will sound for 10 seconds.

Take the lift truck to a service technician immediately for repair if it experiences a decrease in performance.

Operating Techniques

WARNING

Before operating the lift truck, FASTEN YOUR SEAT BELT.

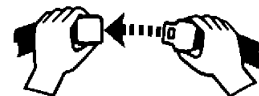

BO190114

There are a number of operations, if not performed carefully, that can cause the lift truck to tip. If you have not read the WARNING page in the front of this Operating Manual, do so NOW. As you study the following information about how to properly operate a lift truck, remember the WARNINGS.

NOTE: S40-70FT, S55FTS lift trucks produced before November 1, 2005 are equipped with the Automatic Locking Retractor (ALR) type seat belts. The seat belt must fasten securely. Make sure the seat belt extends and retracts smoothly and is not frayed or torn. If the seat belt is damaged or does not operate properly, it must be replaced.

NOTE: Lift trucks produced after November 1, 2005 are equipped with the Emergency Locking Retractor (ELR)

style seat belt. When the ELR seat belt is properly buckled across the operator, the belt will permit slight operator repositioning without activating the locking mechanism. If the truck tips, travels off a dock, or comes to a sudden stop, the locking mechanism will be activated and hold the operator's lower torso in the seat.

NOTE: When the Emergency Locking Retractor (ELR) seat belt is properly buckled across the operator, the belt will permit slight operator repositioning without activating the locking mechanism. If the truck tips, travels off a dock, or comes to a sudden stop, the locking mechanism will be activated and hold the operator's lower torso in the seat.

Basic Operating Procedures

Many people make the mistake of thinking that operating a lift truck is the same as driving an automobile. This is not true. A lift truck is a special machine designed to do a much different job than an automobile. Because of the close areas in which a lift truck operates and its other operating characteristics (like rear wheel steering and tail swing), every operator must receive additional training, even if they have a license to drive an automobile.

The following discussion lists basic procedures applicable to lift truck operation.



1. AUTHORIZED AND TRAINED OPERATOR ONLY. This means the operator must be trained (see 29 CFR 1910.178 section I) to drive the lift truck and it means that the operator must thoroughly understand the procedures for lift

truck operation. It also means that a qualified person experienced in lift truck operation must guide the operator through several driving and load handling operations before the operator attempts to operate the lift truck alone. A basic education in proper driving and load handling techniques is absolutely necessary to prepare the new operator for proper defensive driving and to expect the unexpected.

WARNING

This lift truck is designed for handling materials. A lift truck is not designed to lift people. Do not use a lift truck to lift people unless it has been determined that there is no other practical option (scaffolds, elevated work platforms, aerial baskets, etc.) to perform the needed work.



BO190567

If a lift truck is used to elevate a worker, a safety platform must be attached to the forks and carriage. The platform must be specially built to meet or exceed the requirements of ANSI/ITSDF B56.1. It must have a solid floor with a surface to prevent the feet of the worker from slipping, hand rail, toe board, and a screen or

shield at least 2 m (7 ft) high between the people on the platform and the lift mechanism.

The combined weight of the platform, load, and personnel is not to exceed one-half of the capacity as indicated on the nameplate of the truck on which the platform is used.

Before anyone is allowed in the platform, lift and lower the mast slowly with the platform in place to make sure the mast functions properly. Apply the parking brake. Do not travel with people in the platform. The operator

must remain at the controls. Watch for overhead obstructions.



2. NO RIDERS. A lift truck is built for only one person – the operator. It is dangerous for anyone to ride on the forks or anywhere else on the lift truck.

3. ADJUST SEAT - INTERNAL SUSPENSION.

Seat Position Adjustment (Swivel Seat)

- The seat swivels 10.5 degrees to the right to allow the operator a more ergonomic position when driving in reverse.
- The seat swivels 5 degrees to the left to allow an easier exit of the truck.
- The neutral position is shown in **Figure 12**.

Seat Adjustment for Operator Weight

CAUTION

A major cause for high Whole Body Vibration is caused by the operator not adjusting the seat to his/her weight.

NOTE: It is important to adjust the weight setting for each operator.

NOTE: The seat is designed for a maximum weight of 135 kg (298 lb)

- The target is for the "ride indicator" to fall between the arrows when the operator sits upright in the seat with the feet positioned on the pedals. This ensures that the operator is set at the midpoint of the 40 mm (1.57 in.) suspension.
- The weight adjustment knob can be turned left or right to increase or decrease the weight resistance. As the weight adjustment knob is turned the "stiffness" of the suspension can be felt to increase or decrease depending on which way the weight adjustment knob is turned.

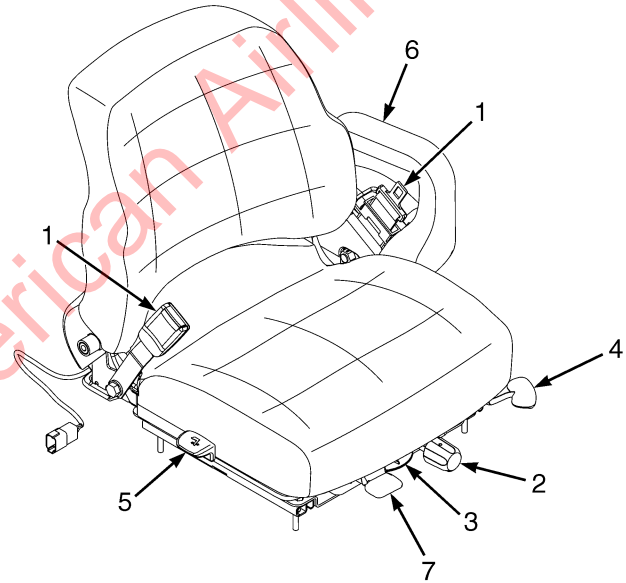

BO190630

Figure 12. Seat Adjustment - Internal Suspension

Legend for Figure 12

1. SEAT BELT
2. WEIGHT ADJUSTMENT KNOB
3. RIDE POSITION INDICATOR
4. FORWARD/BACKWARD ADJUSTMENT LEVER
5. BACKREST ANGLE ADJUSTMENT LEVER
6. ARMREST
7. SWIVEL LATCH RELEASE LEVER

4. ADJUST SEAT - FULL SUSPENSION.

Seat Position Adjustment (Standard Seat)

- Fore and aft adjustment – it is recommended that the seat be adjusted so that the thigh is horizontal to the ground so that the best ergonomic position is achieved. See **Figure 13**.

Seat Position Adjustment (Swivel Seat)

- The seat swivels 12 degrees to the right to allow the operator a more ergonomic position when driving in reverse.
- The seat swivels 5 degrees to the left to allow an easier exit of the truck.
- The neutral position is shown in **Figure 13**.

Seat Adjustment for Operator Weight



CAUTION

A major cause for high Whole Body Vibration is caused by the operator not adjusting the seat to his/her weight.

NOTE: It is important to adjust the weight setting for each operator.

NOTE: The seat is designed for a maximum weight of 135 kg (298 lb)

- The target is for the "ride indicator" to fall between the arrows when the operator sits upright in the seat with the feet positioned on the pedals. This ensures that the operator is set at the midpoint of the 80 mm (3.5 in.) suspension.
- The handle can be turned as shown to increase or decrease the weight resistance, pull handle out before turning. As the handle is turned the "stiffness" of the suspension can be felt to increase or decrease depending on which way the handle is turned.

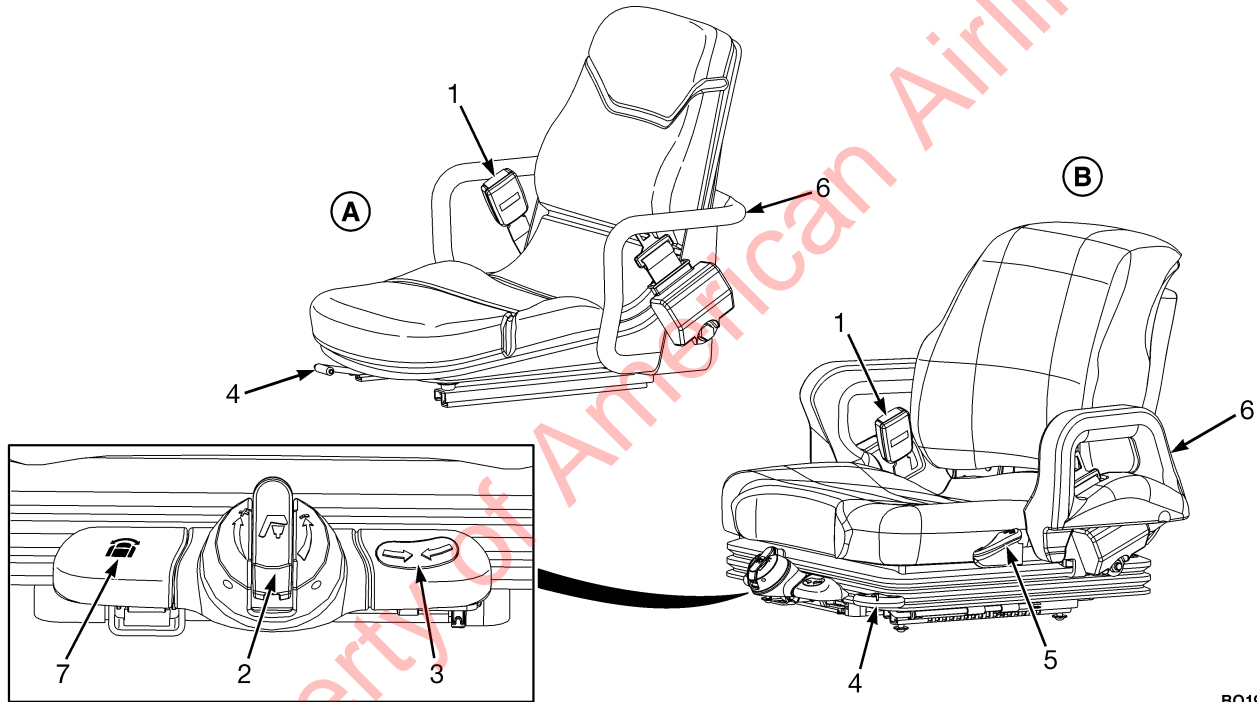

BO190621

Figure 13. Seat Adjustment - Full Suspension

Legend for Figure 13**A. STANDARD, NON-SWIVEL SEAT**

1. SEAT BELT
2. WEIGHT ADJUSTMENT KNOB
3. RIDE POSITION INDICATOR
4. FORWARD/BACKWARD ADJUSTMENT LEVER

B. FULL SUSPENSION SWIVEL SEAT

5. BACKREST ANGLE ADJUSTMENT LEVER
6. ARMREST
7. SWIVEL LATCH RELEASE LEVER

5. Do not drive a lift truck into an elevator unless authorized to do so. Approach the elevator slowly. After the elevator is properly leveled, the lift truck must be centered so that the elevator is balanced.

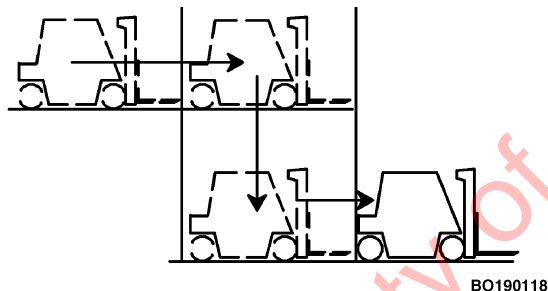

When the lift truck is in the proper position in the elevator, set the brakes, put the controls in **NEUTRAL** and shut off the power. It is advisable that all other personnel leave the elevator before the lift truck enters or leaves.

6. Drive carefully, observe traffic rules, and be in full control of the lift truck at all times. Be completely familiar with all the driving and load handling techniques contained in this **Operating Manual**.

**Driving and Direction Changes**

KNOW YOUR TRANSMISSION OPTION. Lift trucks covered in this manual built prior to January, 2011, can be equipped with a Basic Powershift (iron case), Powershift 1 Speed (aluminum case gear drive) or DuraMatch (1 speed) Transmission. Lift trucks covered in the manual built after January, 2011, will be equipped with a Powershift 1 Speed (aluminum case chain drive) or DuraMatch (1 speed) Transmission. Read the following sections carefully. See **Table 7** and **Figure 14** for the features and operational differences in these transmission types.

Table 7. Transmissions

Operational Feature	Basic Powershift or Powershift 1 Speed Transmission	DuraMatch Transmission
Electronic Inching	Yes	Yes
Electronic Control of Direction Changes	Yes	Yes
Auto Deceleration	–	Yes
Controlled Power Reversal	–	Yes
Roll Reduction Feature	–	Yes
Roll Back Feature	–	Yes
Reduced Drive Tire Slippage	–	Yes



HO210009

1. BASIC POWERSHIFT TRANSMISSION
2. DURAMATCH TRANSMISSION
3. POWERSHIFT 1 SPEED TRANSMISSION

Figure 14. Transmission Labels

General

The lift truck can have either a MONOTROL® pedal or a Direction Control Lever to control the transmission. The selected direction of travel is shown on the display switch cluster. See **Figure 7**. If the lift truck has a MONOTROL® pedal, push on the left side of the pedal to go **FORWARD**, or the right side of the pedal to go in **REVERSE**. If the lift truck has a direction control lever, move the lever toward

the front of the lift truck to go **FORWARD** and toward the rear of the lift truck to go in **REVERSE**.

Normal Operations

In normal operating conditions, either at start or while driving, the lift truck can only be maintained at a stopped position by applying the service brake or parking brake.

When moving away from a stop:

1. Select direction while maintaining braking.
2. Depress the accelerator or MONOTROL® pedal.
3. Release the brakes (parking and/or service brake)

Depress the accelerator or MONOTROL® pedal to ensure the lift truck will move in the selected direction when the brakes are released.

Due to variable load and grade conditions, this procedure minimizes the possibility of the lift truck traveling in a direction opposite to the one selected.

Standard Operator Presence System

WARNING

Always make sure the parking brake is fully applied before leaving the lift truck. If the operator leaves the lift truck without applying the parking brake, a seat activated switch will shift the transmission to neutral, and sound an alarm for 10 seconds. If the lift truck is left on a grade, without the parking brake fully applied, the lift truck will freewheel down the grade, possibly causing injury or property damage.

Lift trucks produced after November 1, 2005 are equipped with an Operator Presence System (OPS). The OPS feature has an electrical switch in the seat which senses the presence of the operator. This allows the transmission in internal combustion engine trucks to be engaged only when the operator is in the seat. The OPS is designed with slight delay in the seat switch to allow the operator to reposition himself without disengaging the transmission. When the seat switch disengages the transmission (neutral position), the operator must depress the service brake pedal to re-engage the traction (travel mode).

A switch in the operator's seat will automatically shift the transmission to neutral within 1-2 seconds when the opera-

tor leaves the seat of the lift truck with the engine running and without applying the parking brake.

If the lift truck is equipped with a Direction Control Lever and the operator leaves the seat without engaging the parking brake, the "N" indicator light on the Display Switch Cluster will illuminate regardless of the position of the Direction Control Lever. When the operator returns to the seat, to resume travel, the Direction Control Lever must be moved to the "N" position, then to the desired direction of travel.

If the lift truck is equipped with a MONOTROL® pedal and the operator leaves the seat without engaging the parking brake, the "N" indicator light on the Display Switch Cluster will illuminate regardless of the position of the MONOTROL® pedal. When the operator returns to the seat, the indicator light will change from "N" to the direction of travel that the MONOTROL® pedal was last in when the operator left the lift truck. The operator can resume travel by depressing the MONOTROL® pedal.

Optional Operator Presence System

WARNING

ALWAYS make sure the parking brake is fully applied before leaving the lift truck. If the operator leaves the lift truck without applying the parking brake, a seat activated switch will shift the transmission to neutral and disable hydraulic mast functions. An alarm will sound for 10 seconds. If the truck is left on a grade, without the parking brake fully applied, the lift truck will freewheel down the grade, possibly causing injury or property damage.

The lift trucks covered in this manual may be equipped with an Optional Operator Presence System. This features an electrical sensor switch in the seat which senses the presence of the operator and a seat belt switch which detects when the seat belt is fastened. This system is designed with a slight delay in the seat switch and seat belt switch to allow the operator to reposition himself without disengaging the transmission and disabling the hydraulic mast functions.

The operator must be on the seat and the seat belt must be fastened before engaging the starter. If the operator leaves the seat while the truck is moving, or does not apply the

parking brake before getting off the seat, the seat switch will disengage the transmission and disable the hydraulic mast functions.

When the operator returns to the seat, if it was not set, the parking brake must be applied and released.

Basic Powershift and Powershift 1 Speed Transmissions

WARNING

DO NOT select the travel direction if the accelerator is depressed. The lift truck will move rapidly and can cause damage or injury.

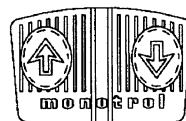

A



B



C

HO190512

- A. MONOTROL PEDAL
- B. ACCELERATOR PEDAL
- C. DIRECTION CONTROL LEVER

CAUTION

The drive train can be damaged if the lift truck is traveling too fast when the controls are changed to the opposite direction of travel.

The operator can change the direction of travel at slow travel speeds (less than a walking speed), but the mast must not be in a raised position. If the lift truck is moving rapidly, slow to a walking speed before changing the direction of travel.

DuraMatch

The DuraMatch (1 speed) transmission is equipped with Controlled Power Reversal, Auto-Deceleration, Roll Reduction, Roll Back, and Reduced Drive Tire Slippage features. See **Table 7**.

Operators should be trained and become familiar with these operating features before transporting loads.

Controlled Power Reversal

WARNING

The factory settings are set for most load handling applications, but may require adjustment for special applications to avoid load damage or personal injury

due to rapid direction reversals and unstable loads. The factory settings for the Controlled Power Reversal feature can be changed by a Hyster Service Technician when required to meet special application requirements.

The DuraMatch transmission allows the operator to change travel direction at any travel speed without damaging the transmission. The operator is still responsible for control of the truck and the stability of the load. Operators should be trained and become familiar with these operating features before transporting loads.

When a direction change is selected, the lift truck's Vehicle Management System automatically reduces engine speed to idle and activates transmission braking. The operator controls the level of transmission braking, or deceleration, with the use of the accelerator or MONOTROL® pedal. Depressing the accelerator or MONOTROL® pedal increases the amount of transmission braking before the lift truck begins to move in the opposite direction. Releasing the accelerator or MONOTROL® pedal after selecting a direction change, reduces the amount of transmission braking. Application of the service brakes allows the operator to bring the lift truck to a complete stop at any time. Once the

truck stops and travel direction changes, the normal control of the accelerator or MONOTROL® pedal returns.

The operator should always consider the load that is being carried, and keep the carriage lowered, when making a controlled power reversal or using transmission braking.

Auto-Deceleration Feature

WARNING

The factory settings are set for most load handling applications, but may require adjustment for special applications to avoid load damage or personal injury due to rapid direction reversals and unstable loads.

The factory settings for the Auto-Deceleration Feature can be changed by a Hyster Service Technician when required to meet special application requirements.

Provides transmission braking, or deceleration, when the accelerator or MONOTROL® pedal is released at vehicle travel speeds greater than operator walking speed. The amount of deceleration is controlled by the accelerator or MONOTROL® pedal position. Releasing the accelerator or MONOTROL® pedal causes a greater amount of transmission braking. Depression of the accelerator or MONOTROL® pedal increases acceleration. The operator should

always consider the load that is being carried, and keep the carriage lowered when using transmission braking.

Roll Reduction Feature

WARNING

The lift truck is only considered at a controlled stop when the truck is not rolling and the service or parking brake is applied. The operator cannot rely on transmission braking alone to bring the lift truck to a full controlled stop. Failure to use the service or parking brakes could result in damage to the lift truck and/or injury to personnel.

Provides limited transmission braking to stop the lift truck from rolling on level ground or to limit vehicle speeds to less than slow walking speed on minor grades. This feature will attempt to stop the lift truck when the transmission is in either **FORWARD** or **REVERSE**, and both the accelerator or MONOTROL® pedal and inching/brake pedals are released. The transmission cannot stop the lift truck in all conditions. It is the operator's responsibility to use the service or parking brake to stop and hold the lift truck from moving.

Operating Procedures

HYSTER

Roll Back Feature

If the operator uses the brakes to bring the lift truck, regardless of direction selected, to a stop on a grade; then releases the brake, the Roll Back feature limits and controls the speed at which the truck rolls backward or forward. This feature is effective on grades up to 10% and limits the speed to 7.6 cm (3 in.) per second. (The lift truck may roll faster than 7.6 cm (3 in.) per second until the Roll Back feature slows it down.)

Reduced Drive Tire Slippage

Electronically controls engine power and clutch pack engagement during acceleration and reduces the possibility of drive tire wheel spin.

Inching

WARNING

Inching requires coordinated movement of the inching/brake pedal and the accelerator or the pedal. New operators must practice this procedure before attempting to handle loads.

Inching is the movement of a lift truck that allows a slow travel speed while keeping the engine speed high for fast operation of the lift mechanism.

The inching/brake pedal is used to control the inching operation. When the inching/brake pedal is initially applied, the clutch in the transmission is partially disengaged and the movement of the truck is slow. When the inching/brake pedal is fully applied, the transmission is completely disengaged and the brakes are applied. Use the accelerator pedal or pedal to keep the engine speed high while inching.

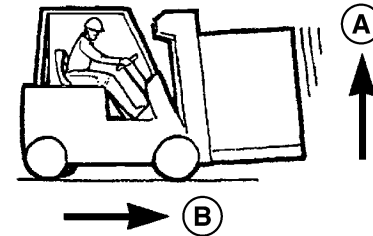

A. FAST

B. SLOW

BO190120

Steering (Turning)

⚠ WARNING
TRAVEL SLOWLY WHEN TURNING. Lift trucks can tip over even at very slow speeds. The combination of speed and the sharpness of a turn can cause a tipover. A lift truck is less stable when the forks are elevated, with or without a load.

⚠ WARNING
IF THE LIFT TRUCK TIPS OVER, DO NOT JUMP OFF! HOLD FIRMLY TO STEERING WHEEL, BRACE YOUR FEET, AND LEAN FORWARD AND AWAY FROM THE POINT OF IMPACT.

Most operators can understand the need to be careful when handling loads. But some operators do not realize that a tipover can occur with an empty lift truck because similar dynamic forces are present. In fact, the lift truck will actually tip over easier when empty, than when loaded with the load lowered. Mast tilt, off-center loads, and uneven

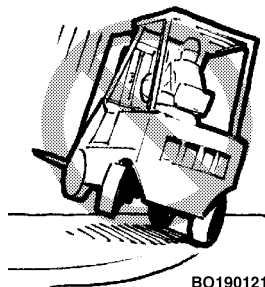

ground will aggravate these conditions and cause the fork-lift to become unstable.

⚠ WARNING
Failure to observe the tail swing area when making a turn can injure or kill someone.

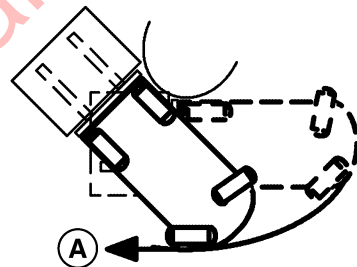

A. TAIL SWING

Because lift trucks are designed to work in a relatively small space, they can turn sharper than some other vehicles. Most lift trucks are steered by the rear wheels and the rear of the lift truck can move to the side very fast during a turn. This movement is called "tail swing". An operator must be aware of tail swing and always check to make sure the tail swing area is clear before turning. Failure to observe

the tail swing area when making a turn can lead to injury or death.

Do not turn on an incline. To reduce the possibility of a tipover, a lift truck must not be driven across an incline.

When possible, keep both hands on the steering wheel. During most loading or unloading operations, the operator steers with the left hand.

The right hand is used to operate the lift, tilt, and attachment controls.

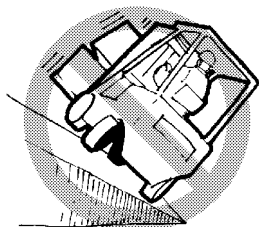

BO190123

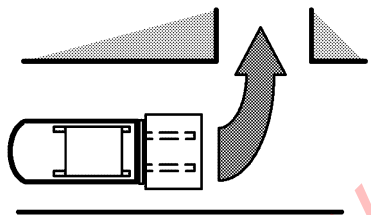

BO190125

When turning the lift truck from a wide aisle into a narrow aisle, start the turn as close to the opposite stock pile as tail swing will permit. This action permits the lift truck to enter the narrow aisle going straight ahead.

Load Handling, General

1. The capacity is the maximum load that the lift truck can handle for the load condition shown on the Nameplate. The operator must know whether or not a load is within the maximum capacity of the lift truck before the load is handled.

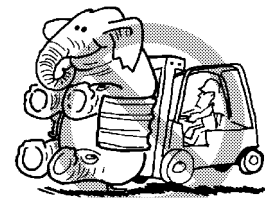

BO190124

However, factors such as weak floors or uneven terrain, loads with a high center of gravity, unevenly distributed loads, or tire condition can mean that the safe working load is less than the capacity shown on the Nameplate. When such conditions exist, the operator must reduce the load so the lift truck will remain stable.

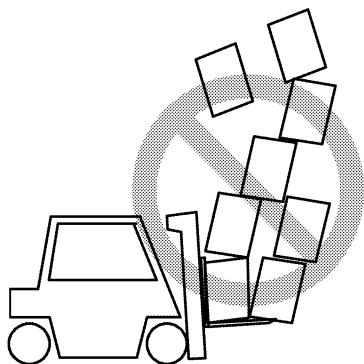

BO190126

⚠ WARNING
Do not handle a load if any loose part of it is above the load backrest or any part of the load is likely to fail.

2. Handle only stable loads. A load can have unstable items that can easily shift and fall on someone.

⚠ WARNING
If the fork/locking pin is not fully engaged, the fork could become unintentionally disengaged.

3. Position each fork the same distance from the center of the carriage. This action will help center the load on the carriage. Set the forks as far apart as possible for maximum support of the load. Center the weight of the load between the forks.

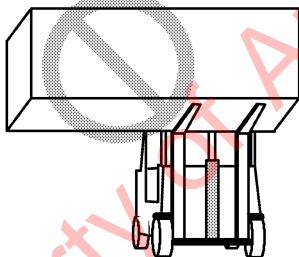

BO190127

If the weight of the load is not centered between the forks, the load can fall from the forks when you turn a corner or hit a bump. An off-center load will increase the possibility of the truck tipping over to the side. Make sure the pins that keep the forks in position are engaged so that the forks cannot move.

4. Check the condition of the driving surface. Make sure the floor will support the weight of the lift truck and the load.

Load Handling, Lifting, Lowering, and Tilting

NOTE: Manual hydraulic levers are standard on the models of trucks covered in this manual. Two optional features are available to control the hydraulic functions: electronic hydraulic mini-levers (see **Figure 8** and **Table 4**) and a joystick (see **Figure 10** and **Table 5**).

The **LIFT** and **TILT** functions are controlled by separate levers or by moving the joystick in different directions. See the **Operator Controls** section in the **Model Description** section for the correct operation.

The speed of the hydraulic functions is controlled by the position of the control levers or the position of the joystick. The farther the hand lever or joystick is moved from the

Operating Procedures

HYSTER

NEUTRAL position, the faster the speed of the hydraulic function.

Do not lift or hit anything that can fall on the operator or a bystander. Remember, a lift truck equipped with an overhead guard and load backrest extension provides reasonable protection to the operator from falling objects, but can not protect against every possible impact.

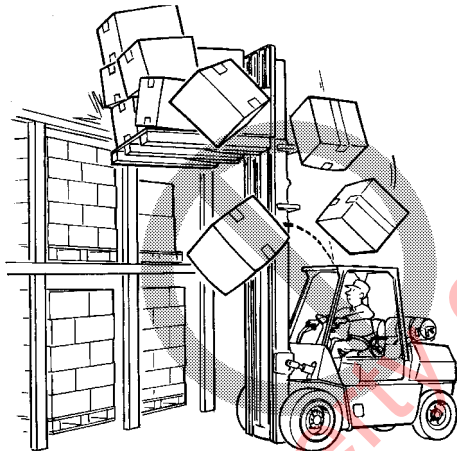

BO190128

A lift truck without an overhead guard provides no such protection and other personnel have no overhead protection. Avoid hitting objects such as stacked material that could become dislodged and fall.

The operator must exercise care while working near such objects. Whether the lift truck is loaded or empty, do not travel with the load or carriage in a raised position.

WARNING

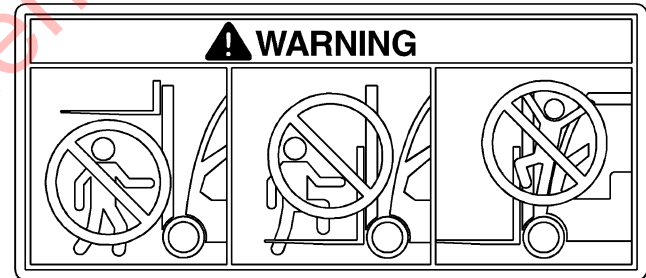

BO190291

Keep yourself and all others clear of the lift mechanism. Never allow anyone under or on the forks.

⚠ WARNING

BO190295

NEVER put hands, arms, head, or legs through the mast or near the carriage or lift chains. This warning applies not only to the operator but also a helper. A helper must not be near the load or lift mechanism while the operator is attempting to handle a load. The lift mechanism has moving parts with close clearances that can cause serious injury.

Lift and lower with the mast vertical or tilted slightly backward from vertical. Tilt elevated loads forward only when directly over the unloading place.

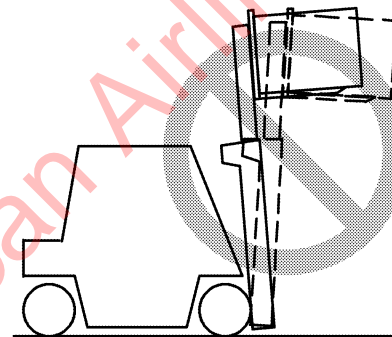
**⚠ WARNING**

The lift truck can tip over forward when the load is raised. Forward tipping is even more likely when tilting forward, braking when traveling forward, or accelerating in reverse.

If the lift mechanism is raised to pick up or deposit a load, keep the tilt angle in either direction to a minimum. Backward and forward tilt are helpful, but they affect side and forward stability. Do not tilt in either direction more than necessary when handling a load that is raised. The lift truck can tip forward if the mast is tilted forward with a load in the raised position.

Operating Procedures

HYSTER

**IF THE LIFT TRUCK TIPS OVER, DO NOT JUMP OFF!
HOLD FIRMLY TO STEERING WHEEL, BRACE YOUR
FEET, AND LEAN FORWARD AND AWAY FROM POINT
OF IMPACT.**

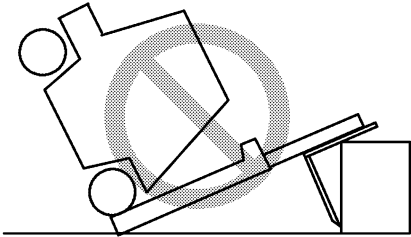

Load Handling, How to Engage and Disengage a Load

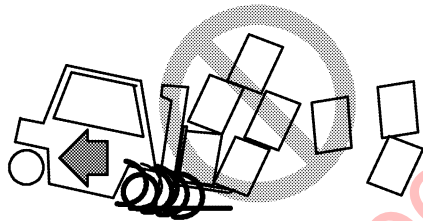

1. Avoid fast starts. Sudden movement can cause the lift truck to tip. People can be hurt or killed and material can be damaged.

Approach the load carefully. Make sure that the truck is perpendicular to the load. Raise the forks to the proper height for engaging the load.

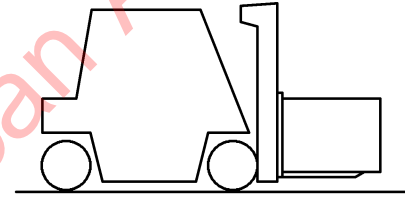

2. Move forward slowly until the forks are in position under the load. The forks must support at least two-thirds ($2/3$) of the length of the load.

Make sure that the load is centered between the forks. Make sure that the forks do not extend past the load so that loads or equipment that are behind the load being lifted are not damaged. Lift the load a small distance from the floor to make sure the lift truck has the capacity to lift the load.

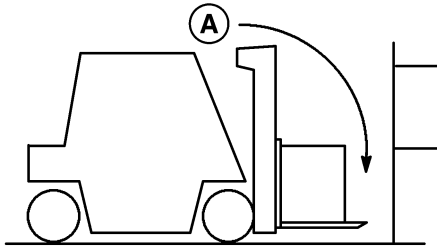

A. BE CAREFUL OF FORKS BEYOND THE LOAD

If the forks are longer than the load, move the forks under the load so that the tips of the forks do not extend beyond the load. Lift the load from the surface. Move backward a few inches, then lower the load onto the surface and inch forward to engage the load against the carriage. Tilt the mast backward just far enough to lift the load from the surface.

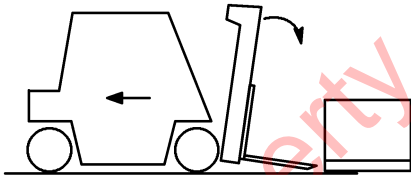

3. When a load is put on the floor, tilt the mast forward to a vertical position and lower the load. Tilt the mast forward to permit smooth removal of the forks. Carefully move the lift truck backward to remove the forks from under the load.

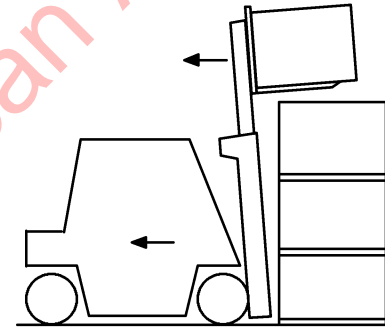

4. If the load is being removed from a stack, slowly move the lift truck away from the stack. When the load is clear of the stack, lower the load for traveling. Always travel with the load as low as possible and tilted backward. Lowering speed is controlled by the position of the control lever. Lower slowly and smoothly. Slowly return the control lever to the neutral position so that the load is not dropped or that the lift truck is not tipped over due to the rapid stop of the load.

WARNING

Move carefully and smoothly when the load is raised over a stack. When the load is elevated the center of gravity of the lift truck and the load is much higher. The lift truck can tip over when the load is raised.

5. To put the load on a stack, align the lift truck with the stack. Raise the load higher than the point where it will be placed. Do not raise the load to a point below where the load is to be placed and "jog" the load up into position. This operation uses added energy. Be careful not to damage or move adjacent loads.

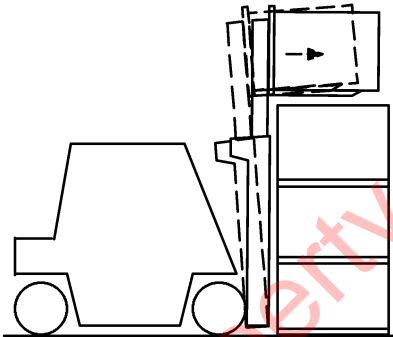

IF THE LIFT TRUCK TIPS OVER EITHER TO THE SIDE OR FORWARD, DO NOT JUMP OFF! HOLD FIRMLY TO STEERING WHEEL, BRACE YOUR FEET, AND LEAN FORWARD AND AWAY FROM THE POINT OF IMPACT.

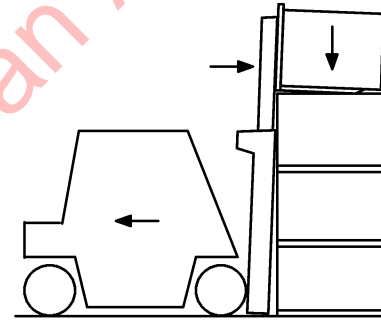

Move forward slowly. When the load is in position, lower the load on to the stack or the rack. Lower the forks just enough to remove them from under the load. Do not lower the forks so that they will drag on the surface under the load. Tilt the mast forward just enough to permit smooth removal of the forks from under the load. Carefully move the lift truck backward to remove the forks from under the load. Lower the forks when traveling.

NOTE: Not every load can be lifted using only the forks of a lift truck. Some loads will require a special attachment.

6. When lifting round objects, use a block behind the object. Tilt the mast forward so that the forks can slide along the floor under the object to be lifted. Tilt the mast fully backward to help keep the load on the forks.

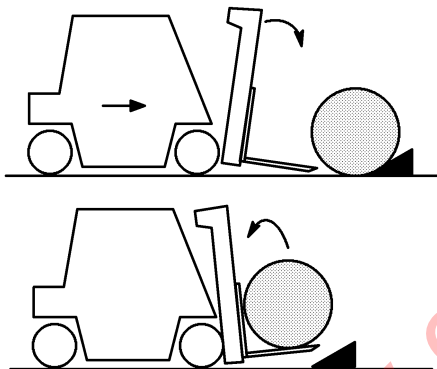

Load Handling, Traveling

1. When traveling with the load lowered, keep the load against the carriage and the mast tilted fully backward. This action will help keep the load on the forks and provide good forward and side stability.

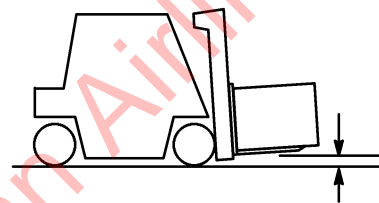

2. Travel with the lift mechanism raised only enough to clear the ground or obstacles.

When the mast, carriage, or load is in a raised position, the stability of the lift truck is reduced. This is also critical when the lift truck is not carrying a load. The ability of the lift truck to resist side tipping can be less on a lift truck without a load than it is on a lift truck with a load in the lowered (travel) position. Therefore, a lift truck without a load is more likely to tip sideways, especially in a turn, than a lift truck with a load carried in the lowered position.



WARNING

Some lift trucks have mirrors for viewing along the side to observe the tail swing area. These mirrors are an aid to the driver, but are **NOT** driving mirrors and must **NOT** be used as such when operating in reverse.

Operating Procedures

HYSTER

Always look in the direction of travel to avoid damage to something or injury to someone.

3. For better visibility with large loads, travel with the load trailing, but always keep a proper lookout in the direction of travel. Normally, direction of travel is determined by the best visibility available to the operator. If the lift truck must travel in a direction where visibility is obstructed, a lookout helper is required. Never drive when visibility is obstructed.

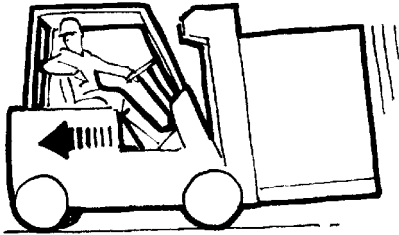

4. When traveling up or down grades in excess of 5% with a **heavily loaded** lift truck, keep the load upgrade to maintain control.

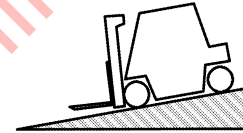
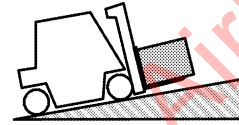

BO190143

When operating an **unloaded** lift truck on a grade in excess of 5%, keep the counterweight upgrade.

5. Watch out for pedestrians at all times. Do not drive up to anyone standing in front of an object. Use extra care at cross-aisles, doorways, and other locations where pedestrians can step into the path of travel of the lift truck.



BO190144

Slow down when approaching blind intersections or turns and sound the horn. The horn is to warn pedestrians that there is a vehicle in the area and to be alert to possible danger.

6. Anytime the lift truck is moving keep arms, legs, etc., inside the operator's compartment. Arms and legs outside the machine can be injured when passing obstructions.

7. Avoid bumps, holes, mud, slick spots, and loose materials that may cause the lift truck to swerve or tip. If unavoidable, slow down.

Different models of lift trucks are designed to operate under different conditions. Solid rubber tire models are designed to operate on relatively smooth, firm surfaces. Lift trucks with pneumatic tires can adapt to more uneven ground. Always make sure you pick the smoothest route for your lift truck.

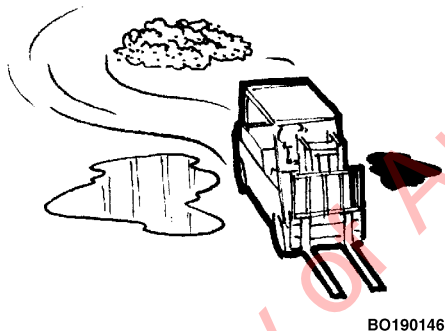
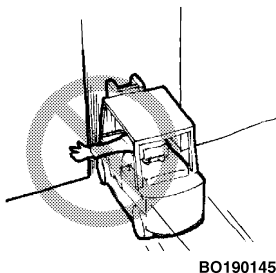

8. Watch clearances, especially forks, mast, overhead guard, and tail swing. A lift truck is designed to perform a wide variety of functions within limited space.

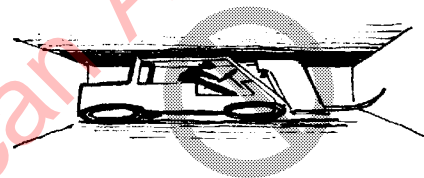

The operator must be aware that the forks can sometimes extend beyond the front of the load. If the forks extend beyond the load, the operator can hit an object or lift another load. Serious accidents can be caused by mast and overhead guards hitting pipes and beams near the ceiling.

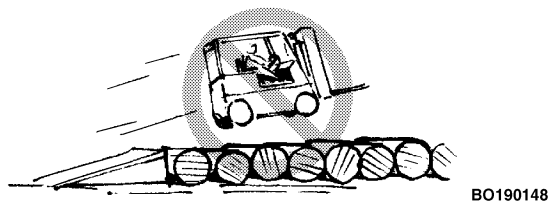

9. Do not indulge in stunt driving or horseplay.

Operating Procedures

HYSTER

10. Do not pass another lift truck traveling in the same direction at intersections, blind spots, or at other dangerous locations.

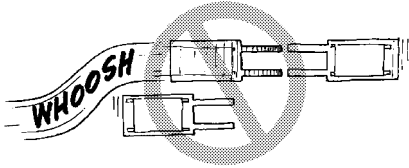

BO190149

11. Stay away from the edge of the road. Keep the wheels of the lift truck on the roadway. If the wheels are allowed to

run off the edge of the travel surface onto soft ground, the lift truck can tip over.

12. Under all travel conditions, operate the lift truck at a speed that will permit it to be brought to a stop in a safe manner.

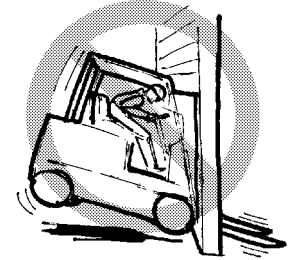

BO190150

Load Handling, Emergency Load Lowering

WARNING

On trucks equipped with an electronic hydraulic control valve, when the electronic signal to the mini-levers or joystick is disrupted, the mast assembly can **ONLY** be lowered with the emergency load lowering valve, located on the main hydraulic valve (see Figure 15). When using the emergency load lowering valve to lower a load, serious injury can result if anyone is near the load or under the load.

WARNING

When power is interrupted on trucks equipped with a manual hydraulic control valve and emergency load lowering valve, the following procedure must be used to lower a load. When lowering a load using this procedure, serious injury can result if anyone is near or under the load.

WARNING

Always lower the mast assembly when leaving the lift truck unattended.

NOTE: The emergency load lowering valve is to be used **ONLY** if the electrical signal to the main control valve has been disrupted and there is a load lifted.

To use the emergency load lowering valve, follow these steps:

1. Move seat all the way forward and raise the steering column to its highest position and open lift truck hood. If lift truck is equipped with an LPG tank, swing the LPG tank to the side before opening the hood.
2. Remove floor mat and floor plate.
3. Turn the emergency load lowering valve two complete turns to the left. See **Figure 15**.
4. When load has been lowered, close the emergency load lowering valve.
5. Install floor plate and floor mat.
6. If truck is equipped with an LPG tank, swing LPG tank back into position on the truck. Close the hood and adjust the seat and steering column.

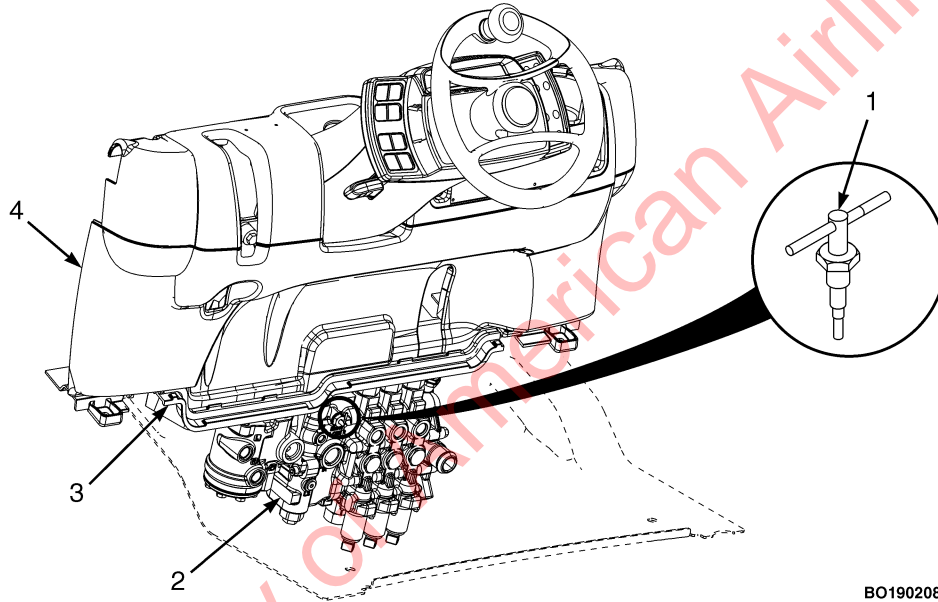

BO190208

- 1. EMERGENCY LOAD LOWERING VALVE
- 2. MAIN CONTROL VALVE

- 3. COWL WELDMENT
- 4. KICK PANEL

Figure 15. Emergency Load Lowering Valve

Highway Trucks, Rail Cars, and Docks

⚠ WARNING

Maintain a safe distance from the edge of docks, ramps, platforms and other similar working surfaces. Watch the “tail swing.” Remember when traveling in the forward direction and the steering wheel is turned to move the lift truck away from the edge of the dock, the rear will swing toward the edge. This action can cause the lift truck to fall off the dock.

IF THE LIFT TRUCK FALLS OFF THE DOCK, DO NOT JUMP OFF! HOLD FIRMLY TO STEERING WHEEL, BRACE YOUR FEET, AND LEAN FORWARD AND AWAY FROM THE POINT OF IMPACT.

Before operating in a highway truck or rail car, observe the following:

- DO NOT use a lift truck to move a rail car.

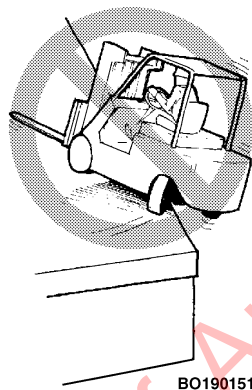

BO190151

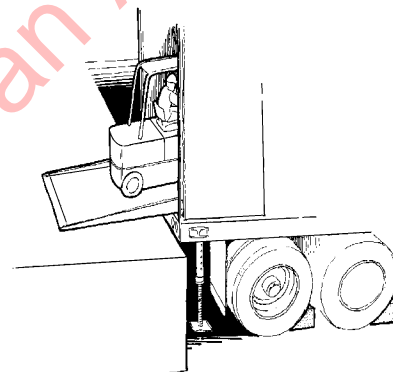

BO190152

- DO NOT use a lift truck to open or close the door on a rail car unless the lift truck has an attachment that is specifically designed for opening and closing rail car doors and the operator is trained in its use.

- Check to make sure that the brakes on the highway truck are set and that wheel blocks have been placed on both sides of the rear wheels (unless a dock locking mechanism is engaged). Fixed jacks may be necessary to support the front and rear of a highway truck trailer to prevent it from moving or tipping during loading or unloading.

- Make sure that the rail car brakes are set and the wheels are blocked while loading or unloading. Do this check so that the rail car will not move due to the movement of the lift truck in and out of the rail car.
- Check the condition of the driving surface. Make sure the floor will support the weight of the lift truck and the load.
- Make sure the dock board is secured, in good condition, and of the proper capacity.
- When entering a rail car, the operator can enter at an angle (if the dock plate or bridge is wide enough). This will reduce the turning required after entering.
- Never leave a parked truck on a dock plate.

Attachments

NOTE: Make sure the Nameplate is correct if an attachment has been installed.



BO190153

If an attachment is installed on the lift truck, make sure the operating instructions are available and understood before operating the attachment. For the operation of attachment control levers, see **Figure 8, Figure 9, Figure 10, Table 4, and Table 5.**

If an attachment is installed on the lift truck, make sure the operating instructions are available and understood before operating the attachment. For the operation of attachment control levers, see and .

Attachments must be removed or installed by trained personnel only.

Disconnecting Attachment Hydraulic Quick-Disconnect Hoses

NOTE: **Step 1** through **Step 4** is to be used for lift trucks equipped with electro-hydraulics.

1. Turn the key switch or keyless switch to the **OFF** position.
2. Disconnect the negative terminal of the battery.

NOTE: If the Quick-Disconnect hose connectors cannot be disconnected, repeat **Step 3** and **Step 4**. If the hoses still cannot be disconnected, notify service personnel.

3. Press the plunger button located on the top of the pressure relief valve, and listen for the flow of hydraulic fluid through the valve when the button is pressed. See **Figure 16**.

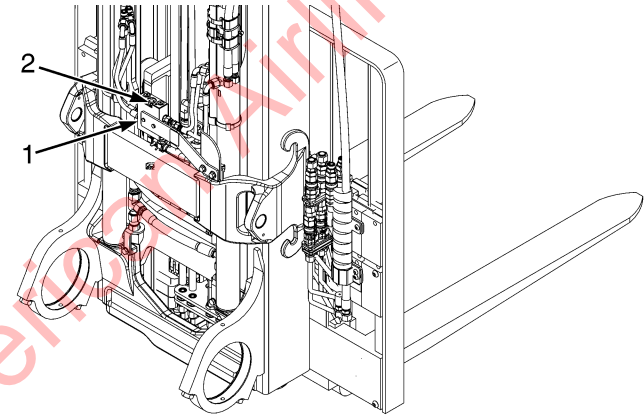

BO170002

1. PRESSURE RELIEF VALVE
2. PLUNGER BUTTON

Figure 16. Quick-Disconnect Procedure

4. Disconnect the Quick-Disconnect hose connectors.

NOTE: **Step 5** through **Step 7** is to be used for lift trucks equipped with manual hydraulics.

5. Turn the key switch or keyless switch to the **OFF** position.

6. Disconnect the negative terminal of the battery.
7. Move the manual hydraulic levers forward and backward to relieve the system hydraulic pressure.
8. Disconnect the Quick-Disconnect hose connectors.

Connecting Attachment Hydraulic Quick-Disconnect Hoses

NOTE: Step 1 through Step 4 is to be used for lift trucks equipped with manual hydraulics.

1. Connect the Quick-Disconnect hose connectors.
2. Connect the negative terminal of the battery.
3. Turn the key switch or keyless switch to the **ON** position and start the engine.
4. Move the manual hydraulic levers forward and backward, and check the hydraulic system for leaks.

NOTE: Step 5 through Step 8 is to be used for lift trucks equipped with electro-hydraulics.

5. Connect the Quick-Disconnect hose connectors.
6. Connect the negative terminal of the battery.
7. Turn the key switch or keyless switch to the **ON** position and start the engine.
8. Move the mini-levers forward and backward, and check the hydraulic system for leaks.

Stopping

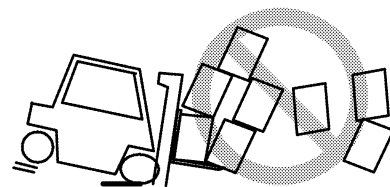

BO190154

Stop the lift truck as gradually as possible. Hard braking and wheel sliding can cause the forklift to tip or the load to fall off of the forks and damage the load or hurt someone.

Parking

The operator must never leave a lift truck in a condition so that it can cause damage and injury. When parking the lift truck, do the following operations:

1. Stop the lift truck and apply the parking brake. Applying the parking brake puts the transmission in **NEUTRAL** when the lift truck has a pedal.
2. Fully lower the forks or carriage. Tilt mast forward until the tips of the forks touch the ground.
3. If equipped, move the Direction Control Lever to the **NEUTRAL** position.
4. Turn the key to the **OFF** position to stop the engine.
5. If the lift truck must be left on an incline, put blocks on the down hill side of the wheels so that the lift truck can not move.

6. Check engine compartment, if operating in areas containing combustible material, and remove foreign debris. See **FIRE HAZARD WARNING** at the beginning of this section.

7. If the lift truck is equipped with an LPG fuel system and the lift truck is not in active use, close the fuel valve at the tank. If the lift truck is going to be left over night or longer, the truck must be parked outside or the LPG tank must be removed and stored outside.

Do not park the lift truck so that it limits access to fire aisles, stairways, and fire equipment.

Maintenance

General

WARNING

Do not make modifications to the lift truck that affect the safe operation of the lift truck. Don't add parts or components that affect visibility.

Do not make repairs or adjustments unless you have both authorization and training. Repairs and adjustments that are not correct can make a dangerous operating condition.

Do not operate a lift truck that needs repairs. Report the need for repairs immediately. If repair is necessary, put a "DO NOT OPERATE" tag in the operator's area. If truck is equipped with a key switch, remove the key.

CAUTION

Disposal of lubricants and fluids must meet local environmental regulations.

NOTE: Unless otherwise noted, overhead views of lift trucks on the following pages are equipped with iron case transmissions.

This section contains a **Maintenance Schedule** and the instructions for maintenance and inspection.

The **Maintenance Schedule** has time intervals for inspection, lubrication, and maintenance for your lift truck. The service intervals are provided in both operating hours recorded on the lift truck hour meter, and in calendar time. Use the interval that occurs first.

The recommendation for the time intervals are for eight hours of operation per day. The time intervals must be decreased from the recommendations in the **Maintenance Schedule** for the following conditions:

- If the lift truck is used more than eight hours per day.
- If the lift truck must work in dirty operating conditions.
- Poor ground conditions.
- Intensive usage at high performance levels or other abnormal conditions will require more frequent servicing.

Your dealer for lift trucks has the equipment and trained service personnel to do a complete program of inspection, lubrication, and maintenance. A regular program of

inspection, lubrication, and maintenance will help your lift truck provide more efficient performance and operate for a longer period of time.

Some users have service personnel and equipment to do the inspection, lubrication, and maintenance shown in the **Maintenance Schedule. Service Manuals** are available from your dealer for lift trucks to help users who do their own maintenance.

Serial Number Data

The serial number for the lift truck is on the Nameplate. It is also on the right side of the frame, under the floor plate.

How to Move a Disabled Lift Truck



WARNING

Use extra caution when towing a lift truck if any of the following conditions exist:

1. Brakes do not operate correctly.
2. Steering does not operate correctly.
3. Tires are damaged.
4. Traction conditions are bad.

5. The lift truck must be towed on a slope.

If the engine cannot run, there is no power available for the hydraulic steering system. This condition can make the lift truck difficult to steer. Poor traction can cause the disabled lift truck or towing vehicle to slide. A slope will also make the lift truck more difficult to stop.

Never lift and move a disabled lift truck unless the disabled lift truck **MUST** be moved and cannot be towed. A lift truck used to move a disabled lift truck **MUST** have a capacity rating equal to or greater than the weight of the disabled lift truck. The capacity of the lift truck used to move a disabled lift truck must have a load center equal to half the width of the disabled lift truck. See the Nameplate of the disabled lift truck for the approximate total weight. The forks must extend the full width of the disabled lift truck. Put the weight center of the disabled lift truck on load center of the forks. Be careful to not damage the under side of the lift truck.

How to Tow the Lift Truck

1. The towed lift truck must have an operator.
2. Tow the lift truck slowly.

3. Using a lift truck or a lifting device that can be attached to the mast (I.E. come-a-long), raise the carriage and forks approximately 30 cm (12 in.) from surface. Install a chain around a mast crossmember and the carriage, to prevent carriage and mast channels from moving.

4. If another lift truck is used to tow the disabled lift truck, that lift truck must have an equal or larger capacity than the disabled lift truck. Install approximately 1/2 of a capacity load on the forks of the lift truck that is being used to tow the disabled lift truck. This 1/2 capacity load will increase the traction of the lift truck. Keep the load as low as possible.

5. Use a towing link made of steel that fastens to the tow pins in the counterweights of both lift trucks.

How to Put a Lift Truck on Blocks

WARNING

The lift truck must be put on blocks for some types of maintenance and repair. The removal of the following assemblies will cause large changes in the center of gravity: mast, drive axle, engine and transmission, and the counterweight. When the lift truck is put on blocks,

put additional blocks in the following positions to maintain stability:

1. Before removing the mast and drive axle, put blocks under the counterweight so that the lift truck cannot fall backward.
2. Before removing the counterweight, put blocks under the mast assembly so that the lift truck cannot fall forward.

The surface must be solid, even, and level when the lift truck is put on blocks. Make sure that any blocks used to support the lift truck are solid, one piece units.

NOTE: Some lift trucks have lifting eyes. These lifting eyes can be used to raise the lift truck so that blocks can be installed.

How to Raise the Drive Tires (See Figure 17)

1. Put blocks on each side (front and back) of the steering tires to prevent movement of the lift truck.
2. Put the mast in a vertical position. Put a block under each outer mast channel.

3. Tilt the mast fully forward until the drive tires are raised from the surface.
4. Put additional blocks under the frame behind the drive tires.
5. If the hydraulic system will not operate, use a hydraulic jack under the side of the frame near the front. Make sure that the jack has a capacity equal to at least half the weight of the lift truck. See the Nameplate.

How to Raise the Steering Tires (See Figure 17)

1. Apply the parking brake. Put blocks on both sides (front and back) of the drive tires to prevent movement of the lift truck.
2. Use a hydraulic jack to raise the steering tires. Make sure that the jack has a capacity of at least 2/3 of the total weight of the lift truck as shown on the Nameplate.
3. Put the jack under the steering axle or frame to raise the lift truck. Put blocks under the frame to support the lift truck.

How to Clean a Lift Truck

CAUTION

Your lift truck may be damaged if water or cleaning agents come in contact with electrical components. **DO NOT directly spray any electrical components, especially connectors, switches, electro-hydraulic controls, battery area, and dash display during the cleaning process.**

Portions of your lift truck may be washed with a non-heated pressure washer. Steam cleaning is not recommended in most instances, as condensation may form in electrical components causing damage or erratic behavior. For cleaning guidelines and components to avoid, see the **Periodic Maintenance** section of the **Service Manual** for your lift truck.

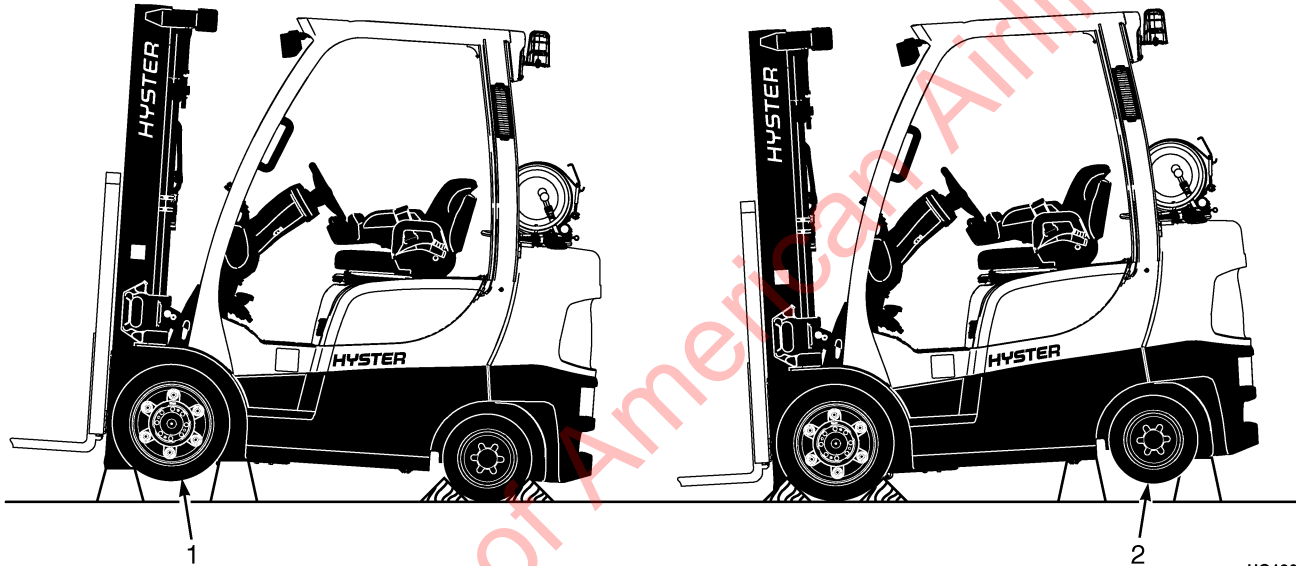

1. DRIVE TIRES

2. STEERING TIRES

HO190349

Figure 17. Put a Lift Truck on Blocks

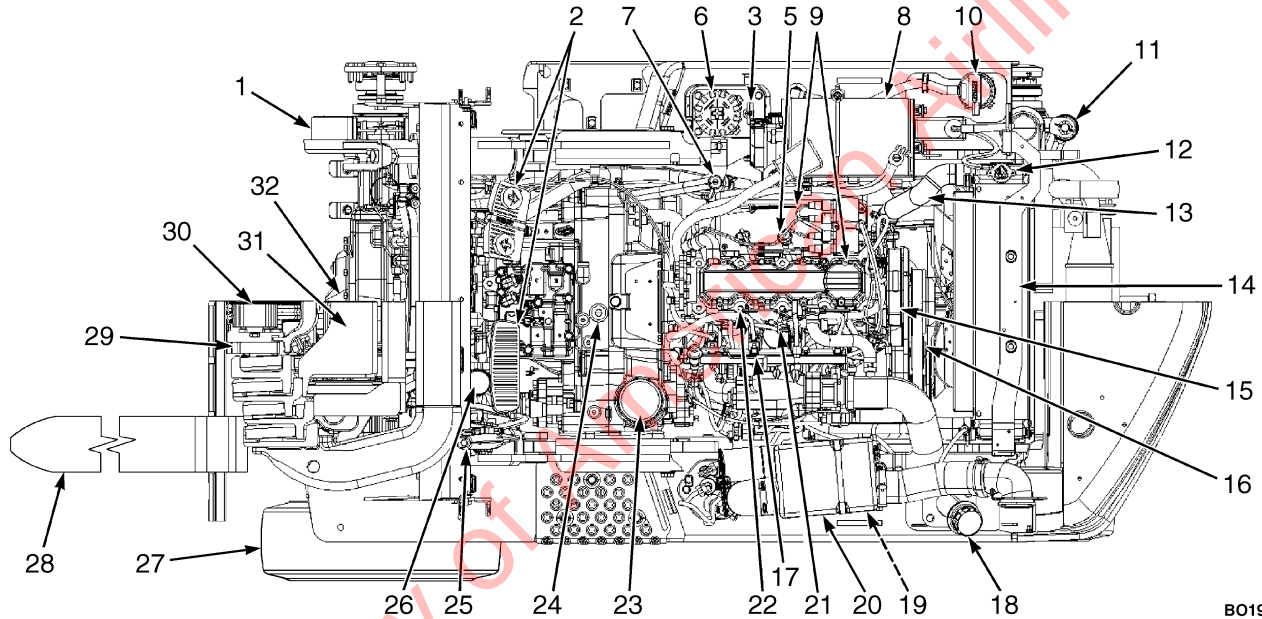

BO190259

Figure 18. GM 2.4L Gas Engine (Prior to January, 2011) Maintenance and Lubrication Points

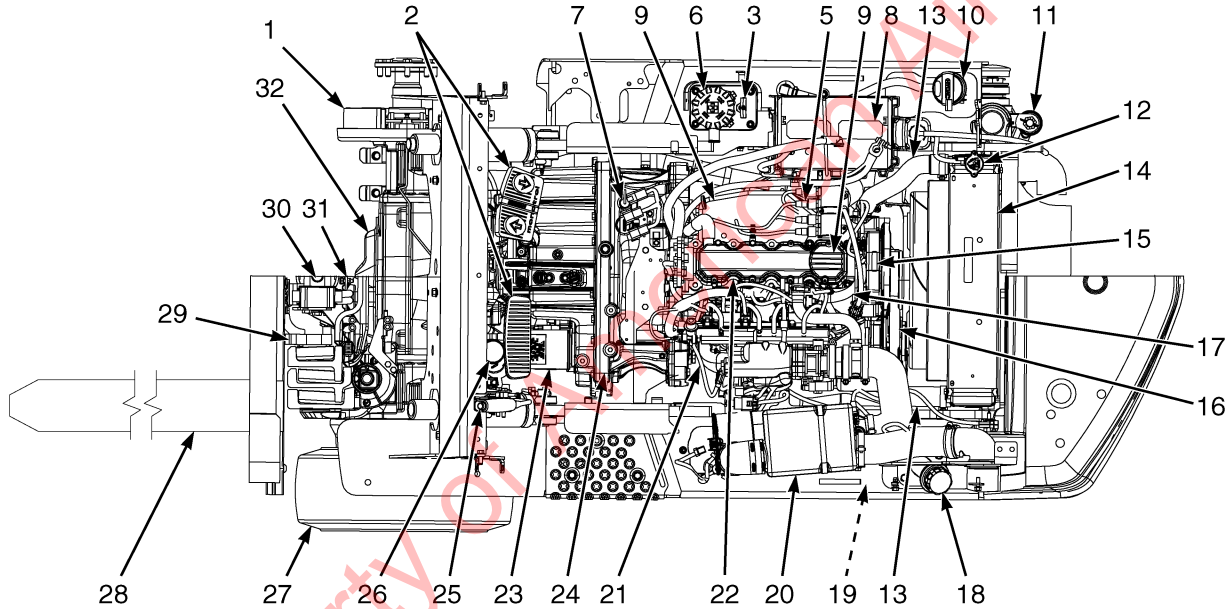

BO190716

Figure 19. GM 2.4L Gas Engine (After January, 2011) Maintenance and Lubrication Points

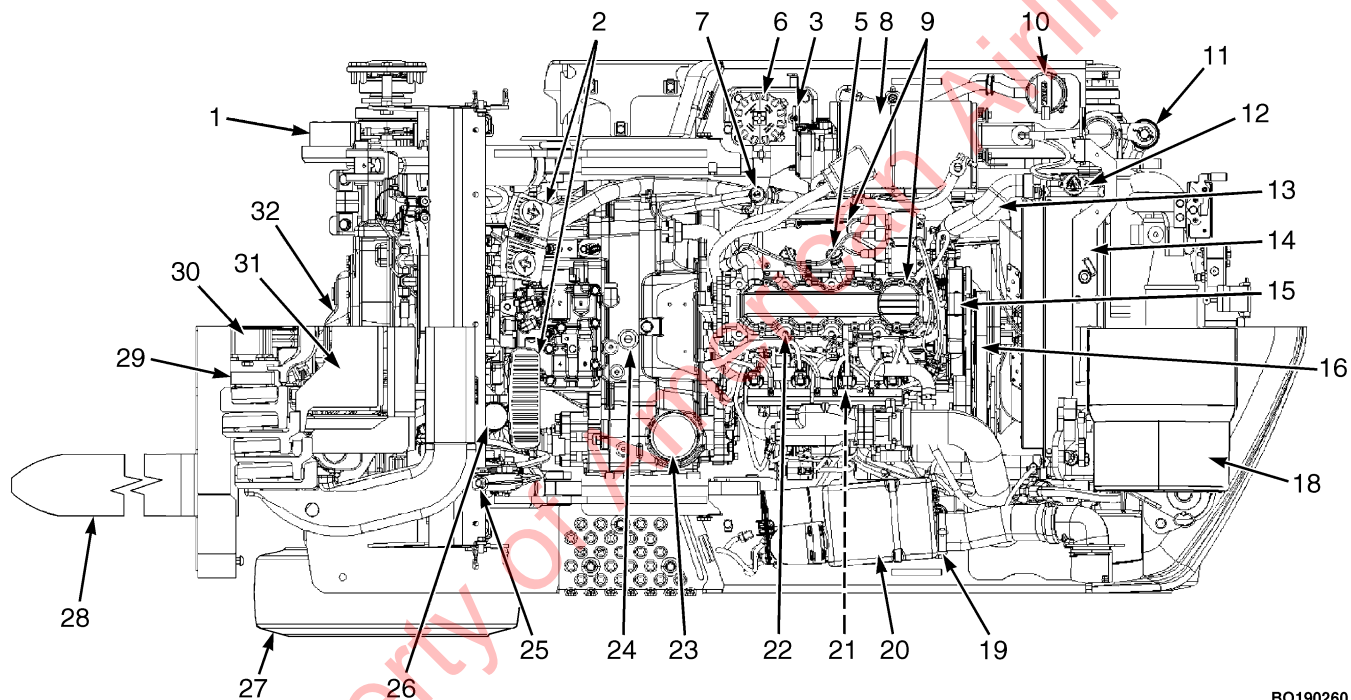

BO190260

Figure 20. GM 2.4L LPG Engine (Prior to January, 2011) Maintenance and Lubrication Points

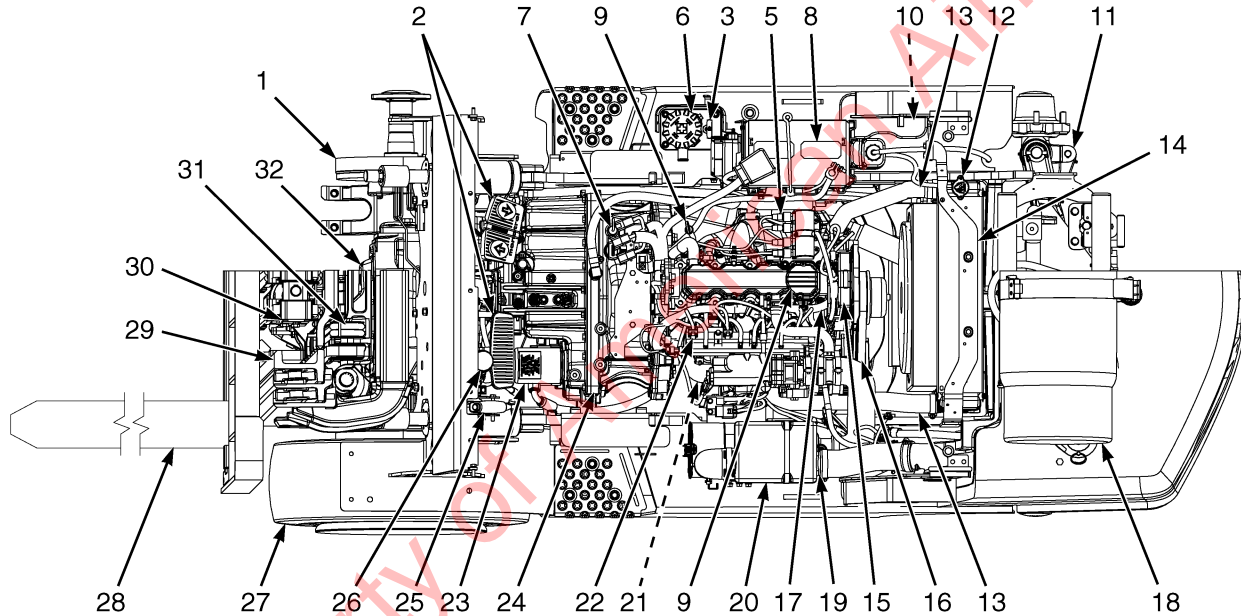

BO190717

Figure 21. GM 2.4L LPG Engine (After January, 2011) Maintenance and Lubrication Points

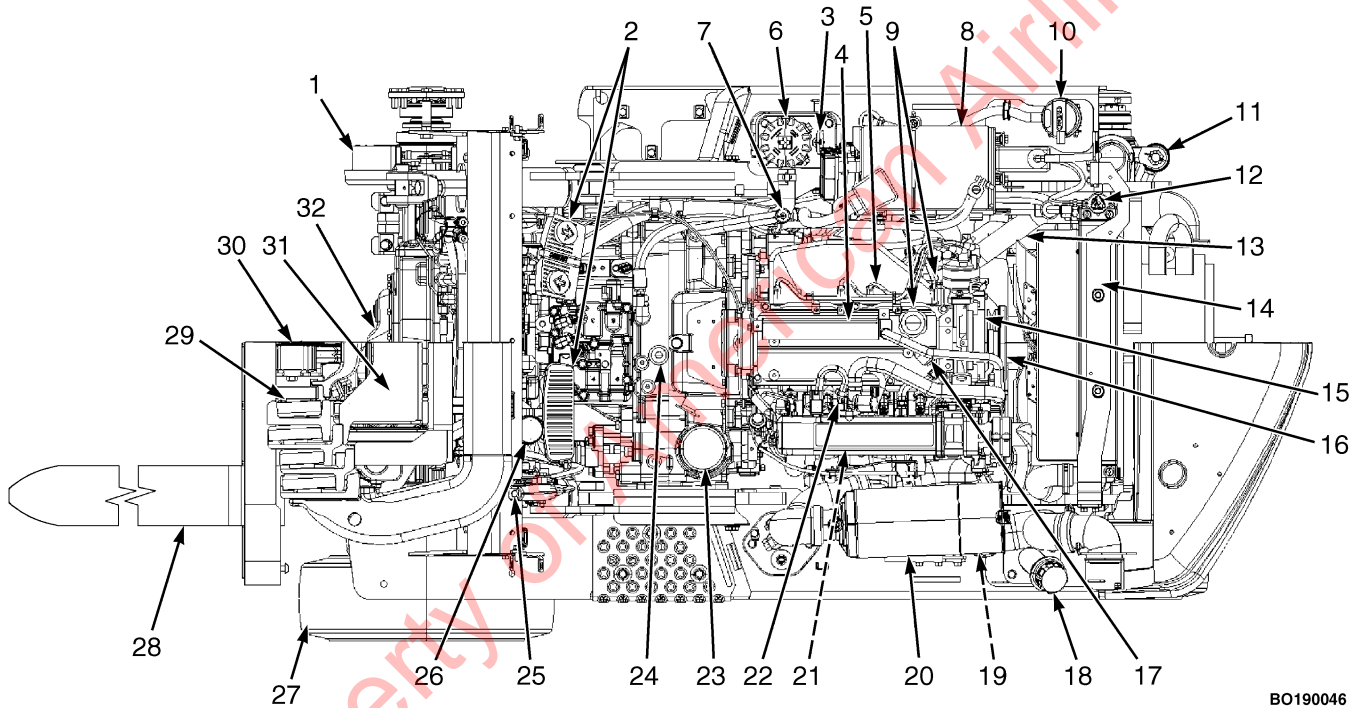

BO190046

Figure 22. Mazda 2.0L and 2.2L Gas Engine (Except 2007 Emission Compliant Engines) Maintenance and Lubrication Points

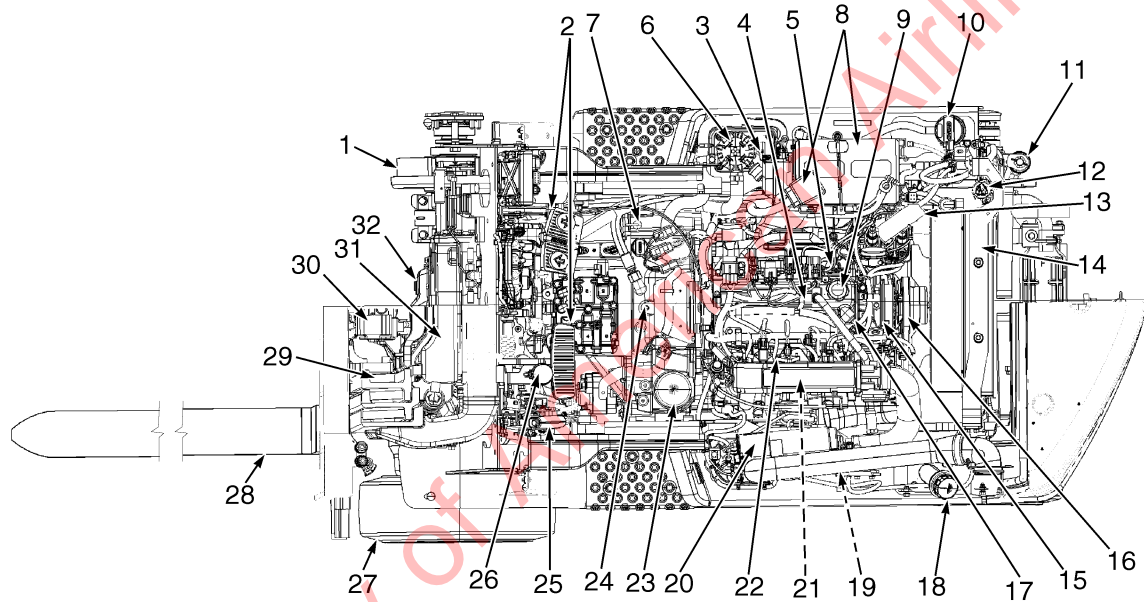

BO190298

Figure 23. Mazda 2.0L and 2.2L Gas Engine (2007 Emission Compliant Engines Only) Maintenance and Lubrication Points

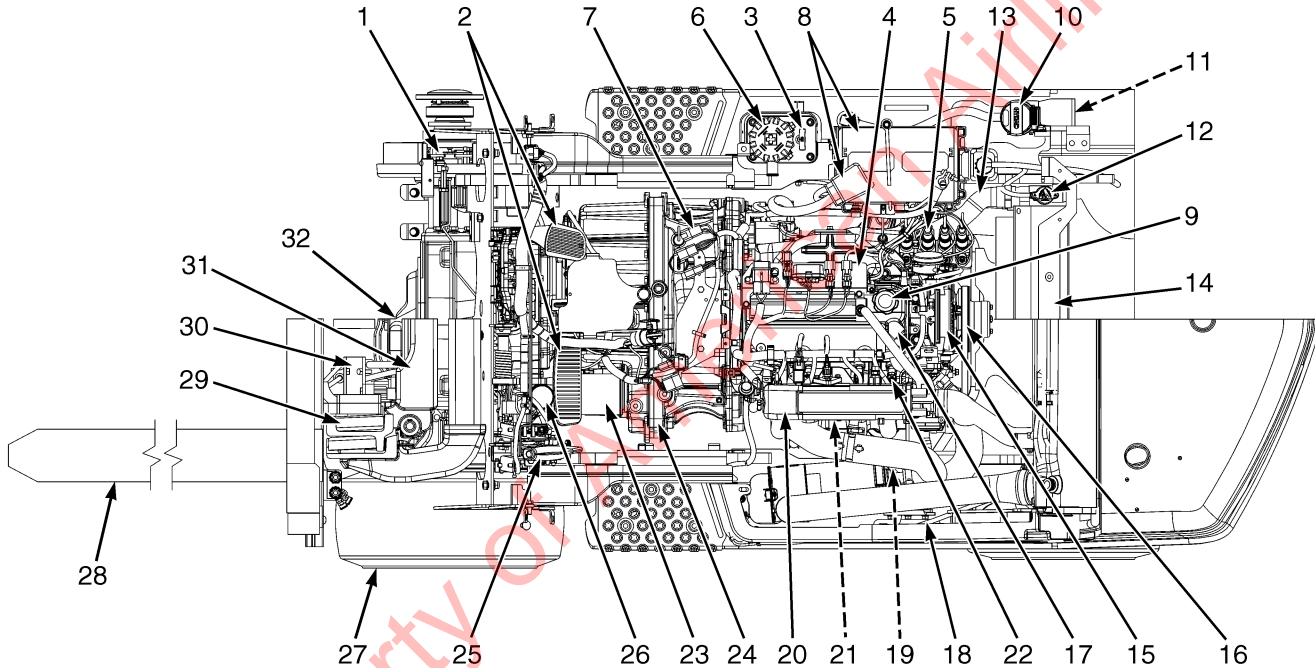

BO210018

**Figure 24. 2010 Mazda 2.0L and 2.2L Gas Engine With Aluminum Case Transmission (Prior to January, 2011)
Maintenance and Lubrication Points**

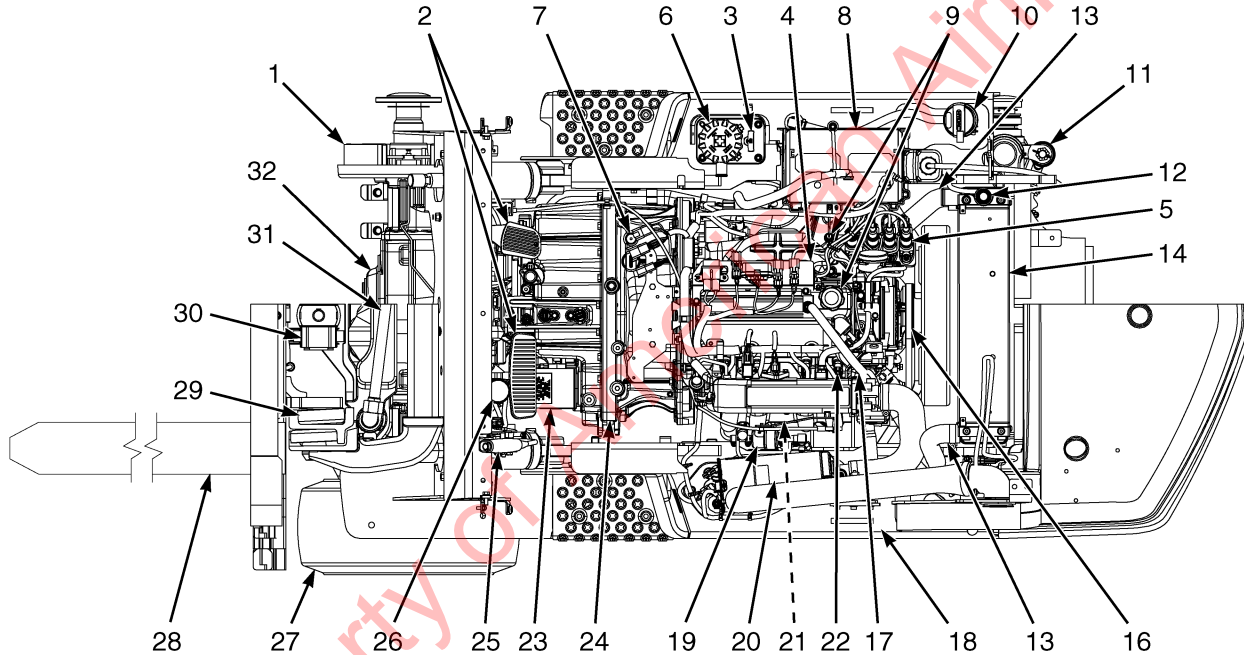

BO190718

Figure 25. Mazda 2.0L and 2.2L Gas Engine With Aluminum Case Transmission (After January, 2011) Maintenance and Lubrication Points

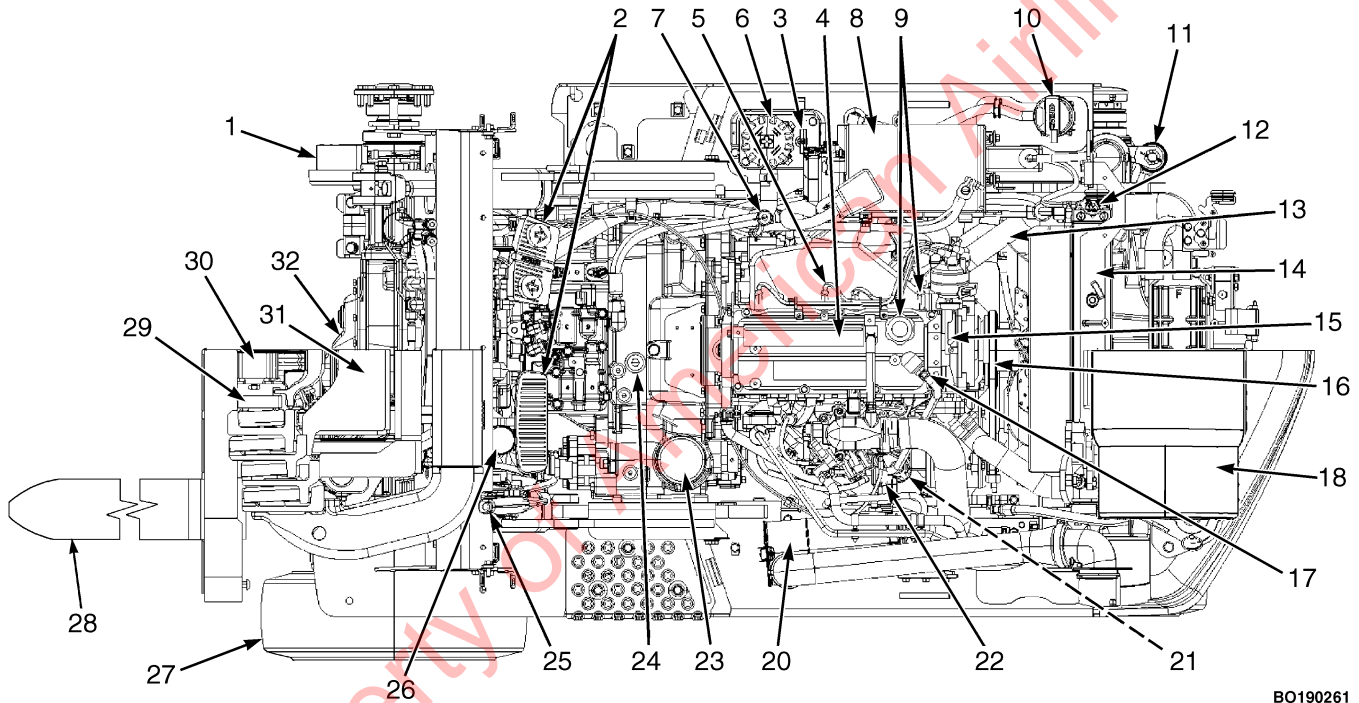

BO190261

Figure 26. Mazda 2.0L and 2.2L LPG Engine (Except 2007 Emission Compliant Engines) Maintenance and Lubrication Points

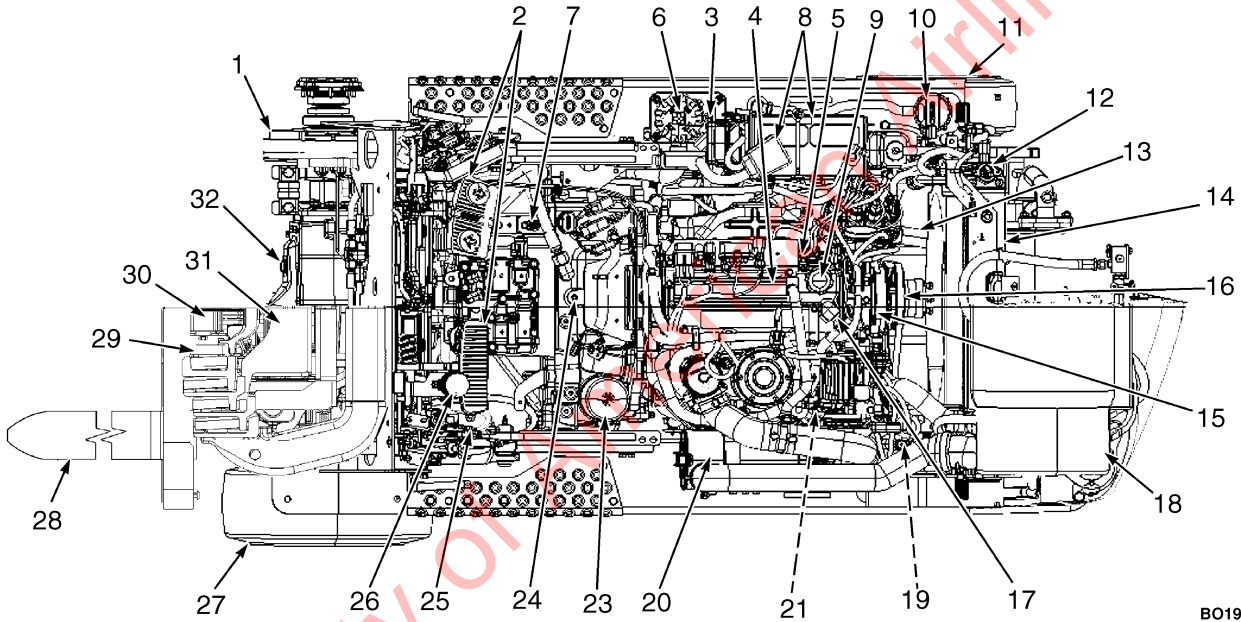

BO190299

Figure 27. Mazda 2.0L and 2.2L LPG Engine (2007 Emission Compliant Engines Only) Maintenance and Lubrication Points

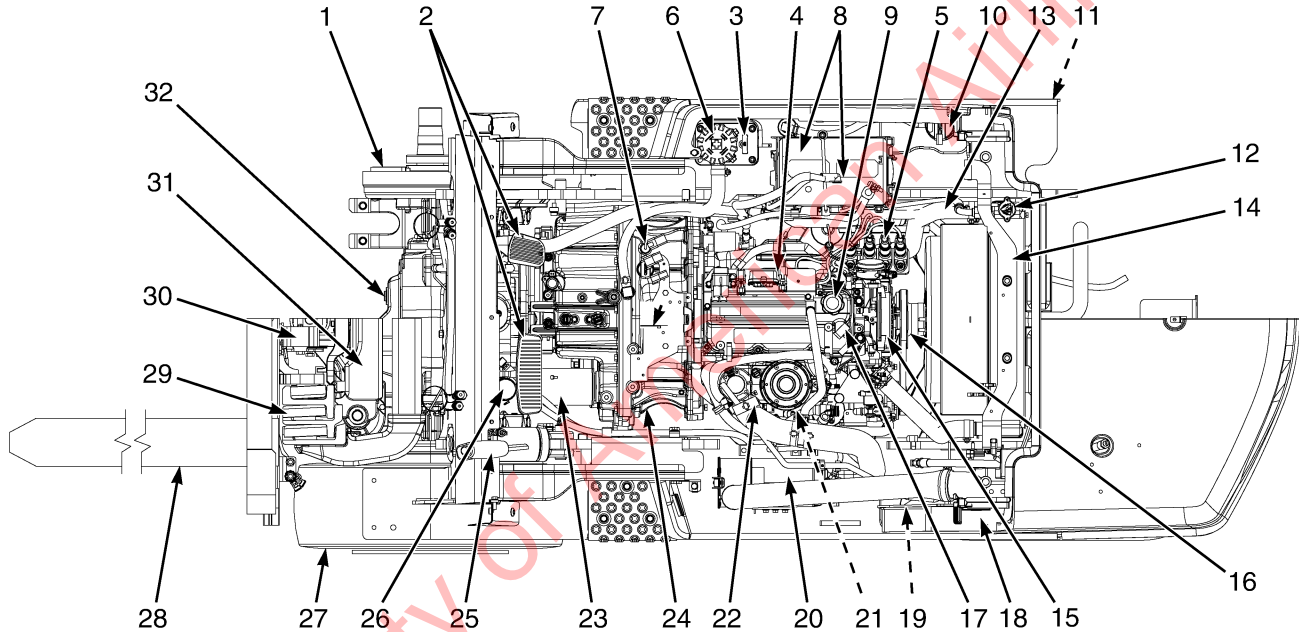

BO210019

**Figure 28. 2010 Mazda 2.0L and 2.2L LPG Engine With Aluminum Case Transmission (Prior to January, 2011)
Maintenance and Lubrication Points**

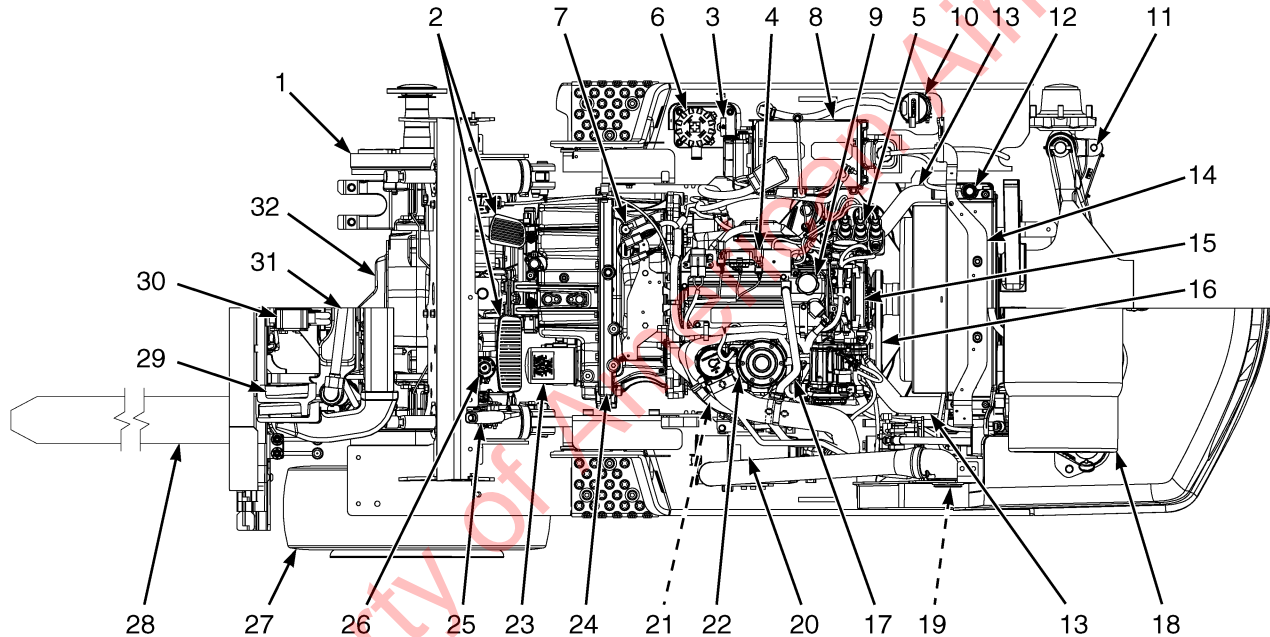

BO190719

Figure 29. Mazda 2.0L and 2.2L LPG Engine With Aluminum Case Transmission (After January, 2011) Maintenance and Lubrication Points

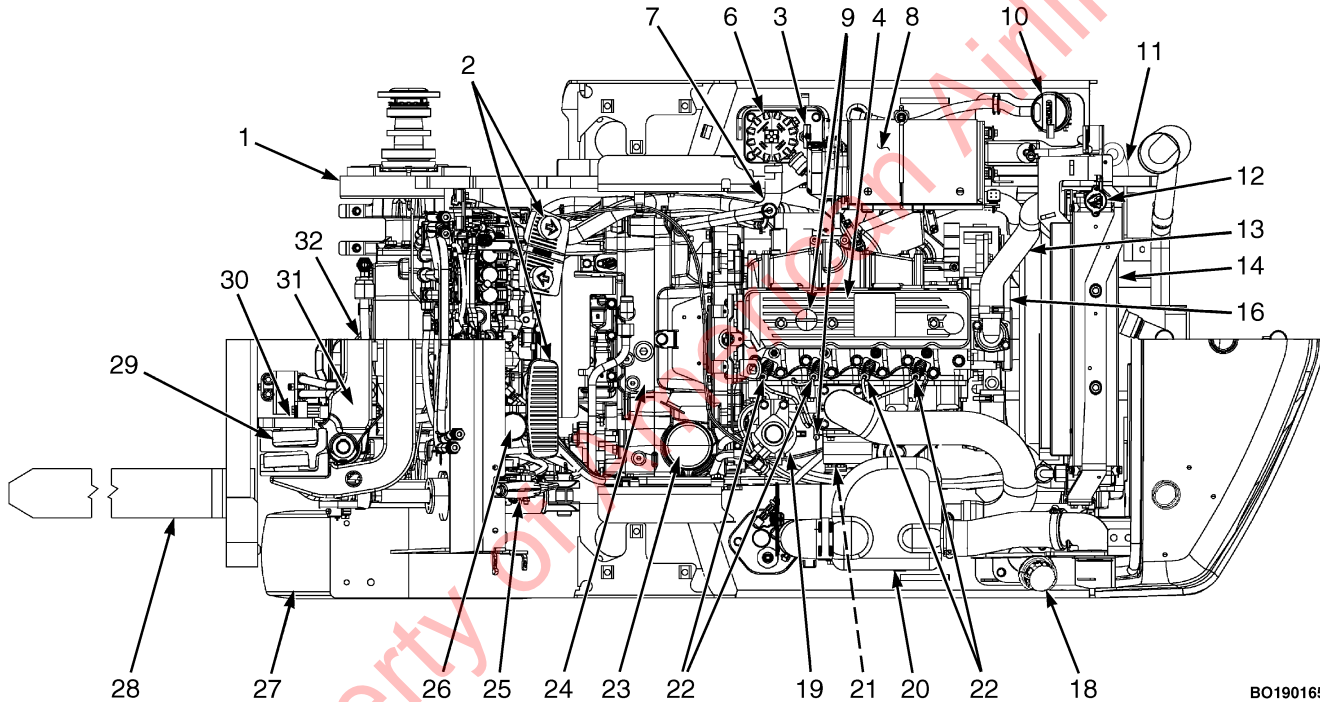

BO190165

Figure 30. Yanmar 2.6L and 3.3L Diesel Engine (Prior to January, 2011) Maintenance and Lubrication Points

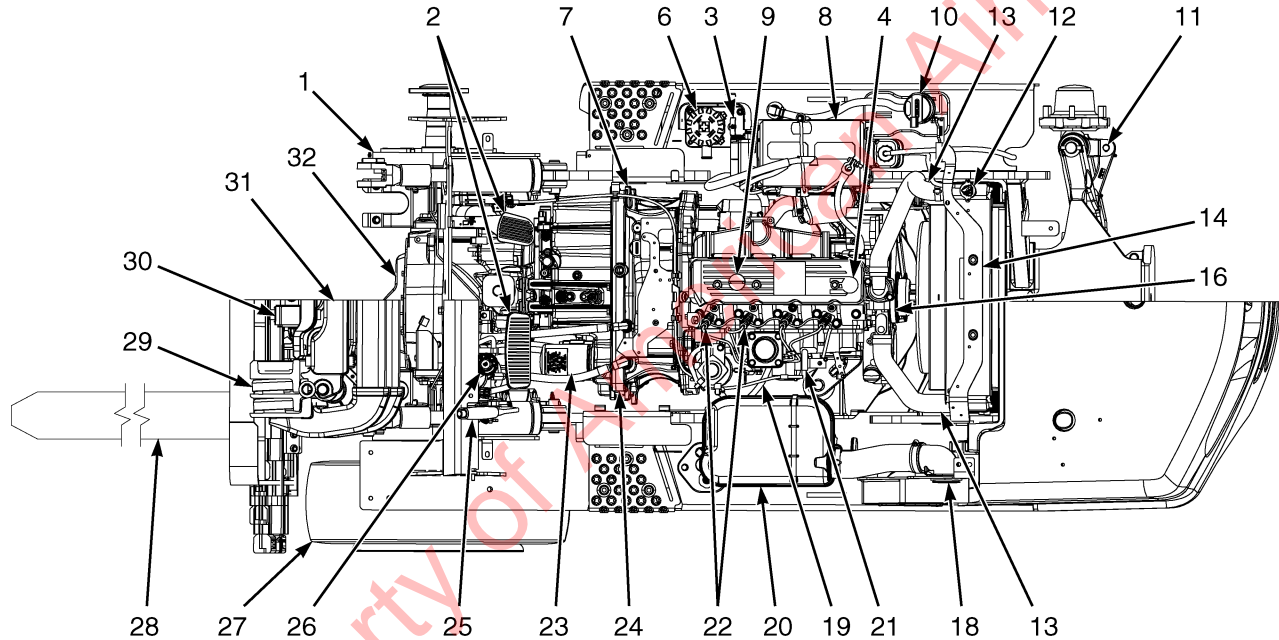

BO190720

Figure 31. Yanmar 2.6L and 3.3L Diesel Engine With Aluminum Case (After January, 2011) Maintenance and Lubrication Points

Maintenance Schedule

Table 8. (See Figure 18 Through Figure 31)

Item No.	Item	8 Hr/ 1 Day	250 Hr/ 6 Mo	500 Hr/ 6 Mo	1000 Hr/ 6 Mo	2000 Hr/ 1 Yr	4000 Hr/ 2 Yr	Procedure or Quantity	Specification
27	TIRES	X						Check Condition.	See Nameplate.
	SAFETY LABELS	X						Replace as Necessary.	See Parts Manual .
30,31	MAST, CARRIAGE, HEADER HOSES, LIFT CHAINS, AND ATTACHMENT	X						Check Condition and Lubrication.	See Parts Manual .
	SEAT BELT, HIP RESTRAINTS AND SEAT RAILS	X						Check Condition and Operation.	
	HOOD AND SEAT LATCHES	X						Check Condition and Operation.	

X = Check C = Change L = Lubricate CIL = Check indicator light during operation

Maintenance Schedule

HYSTER

Table 8. (See Figure 18 Through Figure 31) (Continued)

Item No.	Item	8 Hr/ 1 Day	250 Hr/ 6 Mo	500 Hr/ 6 Mo	1000 Hr/ 6 Mo	2000 Hr/ 1 Yr	4000 Hr/ 2 Yr	Procedure or Quantity	Specification
	ENGINE COMPARTMENT	X						Remove Combustible Materials. See NOTE 5.	
	PAPER APPLICATION Engine Compartment; Truck Components; Exhaust Wraps; Radiator; Radiator Screen, if equipped; Belly Pan, if equipped	X						Check Condition. Clean as Required. Replace as Required. See NOTE 10.	
	CHECK FOR LEAKS - FUEL, OIL, WATER	X						Check for Leaks. See NOTE 1.	
	HYDRAULIC HOSES	X						Check Condition.	See Parts Manual .
13	COOLANT HOSES	X						Check Condition.	See Parts Manual .
18	FUEL TANK (GAS) S40-70FT, S55FTS (F187)	CIL						40.5 liter (10.7 gal)	85 Octane - Gasoline Minimum

X = Check C = Change L = Lubricate CIL = Check indicator light during operation

Table 8. (See Figure 18 Through Figure 31) (Continued)

Item No.	Item	8 Hr/ 1 Day	250 Hr/ 6 Mo	500 Hr/ 6 Mo	1000 Hr/ 6 Mo	2000 Hr/ 1 Yr	4000 Hr/ 2 Yr	Procedure or Quantity	Specification
18	FUEL TANK (GAS) H40-70FT (L177)	CIL						52 liter (13.7 gal)	85 Octane - Gasoline Minimum
18	FUEL TANK (LPG)	CIL						29.9 liter (7.9 gal) 15.2 kg (33.5 lb)	LPG - HD 5, HD 10
18	FUEL TANK (DIESEL) H40-70FT (L177)	CIL						52 liter (13.7 gal)	Diesel No. 2
	HORN, LIGHTS, ALARMS	X						Check Operation.	
1	SERVICE BRAKES	X						Check Operation.	
25	PARKING BRAKE	X						Check Operation.	
	STEERING CONTROLS AND STEERING COLUMN GAS CYLINDER	X						Check Condition and Operation.	
24	TRANSMISSION	X						Check for Leaks.	John Deere JDM J20C

X = Check C = Change L = Lubricate CIL = Check indicator light during operation

Maintenance Schedule

HYSTER

Table 8. (See Figure 18 Through Figure 31) (Continued)

Item No.	Item	8 Hr/ 1 Day	250 Hr/ 6 Mo	500 Hr/ 6 Mo	1000 Hr/ 6 Mo	2000 Hr/ 1 Yr	4000 Hr/ 2 Yr	Procedure or Quantity	Specification
24	TRANSMISSION	X						Check Operation.	
3	HYDRAULIC OIL S40-70FT, S55FTS (F187)	X		X			C	30.1 liter (31.8 qt) See NOTE 2, NOTE 3, and NOTE 16.	ISO VG 46 Hydraulic Oil -15 °C (5 °F) and above See NOTE 17.
3	HYDRAULIC OIL H40-70FT (L177)	X		X			C	39.8 liter (42 qt) See NOTE 2, NOTE 3, and NOTE 16.	ISO VG 46 Hydraulic Oil -15 °C (5 °F) and above See NOTE 17.
6	HYDRAULIC OIL FILTER					C		1 Filter See NOTE 16.	See Parts Manual .
10	HYDRAULIC TANK BREATHER			X		C		Inspect and Replace as Required. See NOTE 5.	See Parts Manual .
8	BATTERY AND CABLE TERMINALS			X				Clean.	

X = Check C = Change L = Lubricate CIL = Check indicator light during operation

Table 8. (See Figure 18 Through Figure 31) (Continued)

Item No.	Item	8 Hr/ 1 Day	250 Hr/ 6 Mo	500 Hr/ 6 Mo	1000 Hr/ 6 Mo	2000 Hr/ 1 Yr	4000 Hr/ 2 Yr	Procedure or Quantity	Specification
9	ENGINE OIL Mazda 2.0L Engine (Gas/LPG)	X CIL	C					3.9 liter (4.1 qt) See NOTE 4 and NOTE 5.	-7 °C (20 °F) and Below SAE 5W-20 16 °C (60 °F) and Below SAE 5W-30 -18 °C (-0 °F) and Below SAE 10W-30 API SM ILSAC GF4 SAE J2362
9	ENGINE OIL Mazda 2.2L Engine (Gas/LPG)	X CIL	C					4.2 liter (4.4 qt) See NOTE 4 and NOTE 5.	-7 °C (20 °F) and Below SAE 5W-20 16 °C (60 °F) and Below SAE 5W-30 -18 °C (-0 °F) and Below SAE 10W-30 API SM ILSAC GF4 SAE J2362

X = Check C = Change L = Lubricate CIL = Check indicator light during operation

Maintenance Schedule

HYSTER

Table 8. (See Figure 18 Through Figure 31) (Continued)

Item No.	Item	8 Hr/ 1 Day	250 Hr/ 6 Mo	500 Hr/ 6 Mo	1000 Hr/ 6 Mo	2000 Hr/ 1 Yr	4000 Hr/ 2 Yr	Procedure or Quantity	Specification
9	ENGINE OIL GM 2.4L Engines (Gas/LPG)	X CIL	C					5.0 liter (5.3 qt) See NOTE 4 and NOTE 5.	-7 °C (20 °F) and Below SAE 5W-20 16 °C (60 °F) and Below SAE 5W-30 -18 °C (-0 °F) and Below SAE 10W-30 API SM ILSAC GF4 SAE J2362
21	ENGINE OIL FILTER Mazda 2.0L and 2.2L and GM 2.4L Engines		C					1 Filter See NOTE 4 and NOTE 5.	See Parts Manual .
X = Check C = Change L = Lubricate CIL = Check indicator light during operation									

Table 8. (See Figure 18 Through Figure 31) (Continued)

Item No.	Item	8 Hr/ 1 Day	250 Hr/ 6 Mo	500 Hr/ 6 Mo	1000 Hr/ 6 Mo	2000 Hr/ 1 Yr	4000 Hr/ 2 Yr	Procedure or Quantity	Specification
9	ENGINE OIL Yanmar 2.6L and 3.3L Engines (Diesel)	X CIL		C				10.2 liter (10.8 qt) See NOTE 4 and NOTE 5.	20 °C (58 °F) and over SAE 40 10 to 30 °C (50 to 86 °F) SAE 30 0 to 20 °C (32 to 68 °F) SAE 20 -16 to 40 °C (3 to 103 °F) SAE 15W-40 -20 to 30 °C (-4 to 86 °F) SAE 10W-30 -10 to 10 °C (14 to 50 °F) SAE 20W -20 to 10 °C (-4 to 50 °F) SAE 10W
21	ENGINE OIL FILTER Yanmar 2.6L and 3.3L Engines (Diesel)			C				1 Filter See NOTE 4 and NOTE 5.	See Parts Manual .
20	AIR FILTER	CIL				C		1 Filter See NOTE 5, NOTE 6, and NOTE 13.	See Parts Manual .

X = Check C = Change L = Lubricate CIL = Check indicator light during operation

Maintenance Schedule

HYSTER

Table 8. (See Figure 18 Through Figure 31) (Continued)

Item No.	Item	8 Hr/ 1 Day	250 Hr/ 6 Mo	500 Hr/ 6 Mo	1000 Hr/ 6 Mo	2000 Hr/ 1 Yr	4000 Hr/ 2 Yr	Procedure or Quantity	Specification
20	AIR FILTER	X				C		1 Filter See NOTE 5, NOTE 6, and NOTE 13.	See Parts Manual .
16	DRIVE BELT Mazda 2.0L and 2.2L Engines (Gas/LPG)		X					Check for Wear and Damage. Adjust as Needed.	
16	DRIVE BELT GM 2.4L Engines (Gas/LPG)		X					Check for Wear and Damage. Adjust as Needed.	
16	DRIVE BELT Yanmar 2.6L and 3.3L Engines (Diesel)			X				Check for Wear and Damage. Adjust as Needed.	

X = Check C = Change L = Lubricate CIL = Check indicator light during operation

Table 8. (See Figure 18 Through Figure 31) (Continued)

Item No.	Item	8 Hr/ 1 Day	250 Hr/ 6 Mo	500 Hr/ 6 Mo	1000 Hr/ 6 Mo	2000 Hr/ 1 Yr	4000 Hr/ 2 Yr	Procedure or Quantity	Specification
	LPG REGULATOR Mazda 2.0L and 2.2L Engines		X					Drain Tar. See NOTE 5.	
	ENGINE IDLE SPEED Mazda 2.0L and 2.2L Engines (Gas/LPG)		X					See NOTE 5.	800 ±25 RPM
	ENGINE GOVERNED SPEED Mazda 2.0L and 2.2L Engines (Gas/LPG)		X					See NOTE 5.	2700 ±25 RPM
	LPG REGULATOR GM 2.4L Engines		X					Drain Tar. See NOTE 5.	
	ENGINE IDLE SPEED GM 2.4L Engines (Gas/LPG)		X					See NOTE 5.	800 ±25 RPM
	ENGINE GOVERNED SPEED GM 2.4L Engines (Gas/LPG)		X					See NOTE 5.	2700 ±25 RPM

X = Check C = Change L = Lubricate CIL = Check indicator light during operation

Maintenance Schedule

HYSTER

Table 8. (See Figure 18 Through Figure 31) (Continued)

Item No.	Item	8 Hr/ 1 Day	250 Hr/ 6 Mo	500 Hr/ 6 Mo	1000 Hr/ 6 Mo	2000 Hr/ 1 Yr	4000 Hr/ 2 Yr	Procedure or Quantity	Specification
	ENGINE IDLE SPEED Yanmar 2.6L and 3.3L Engines (Diesel)			X				See NOTE 5.	825 ±25 RPM
	ENGINE GOVERNED SPEED Yanmar 2.6L Engines (Diesel)			X				See NOTE 5.	2700 ±25 RPM
	ENGINE GOVERNED SPEED Yanmar 3.3L Engines (Diesel)			X				See NOTE 5.	2600 ±25 RPM
17	PCV VALVE			X		C		Replace as Necessary. See NOTE 14.	See Parts Manual .
	OXYGEN SENSOR					X			Check Indicator Light.
4	VALVE ADJUSTMENT Mazda 2.0L and 2.2L Engines (Gas/LPG)				X			Adjust as Required.	Intake 0.15 mm (0.006 in.) Cold Exhaust 0.35 mm (0.014 in.)Cold
X = Check C = Change L = Lubricate CIL = Check indicator light during operation									

Table 8. (See Figure 18 Through Figure 31) (Continued)

Item No.	Item	8 Hr/ 1 Day	250 Hr/ 6 Mo	500 Hr/ 6 Mo	1000 Hr/ 6 Mo	2000 Hr/ 1 Yr	4000 Hr/ 2 Yr	Procedure or Quantity	Specification
4	VALVE ADJUSTMENT Yanmar 2.6L and 3.3L Diesel Engines				X			Adjust as Required.	Intake 0.20 mm (0.008 in.) Cold Exhaust 0.20 mm (0.008 in.)Cold
	TIMING Mazda 2.0L and 2.2L Engines (Gas)				X			Adjust as Required.	6° ±1° BTDC (Orange Mark)
	TIMING Mazda 2.0L and 2.2L Engines (LPG)				X			Adjust as Required.	6° ±1° BTDC (Orange Mark)
19	LPG FUEL FILTER Mazda 2.0L and 2.2L Engines (2007 Emission Compliant Engines Only)				C			1 Filter	See Parts Manual .
	LPG FUEL REGULATOR FILTER Mazda 2.0L and 2.2L Engines (Except 2007 Emission Compliant Engines)					C		1 Filter	See Parts Manual .

X = Check C = Change L = Lubricate CIL = Check indicator light during operation

Maintenance Schedule

HYSTER

Table 8. (See Figure 18 Through Figure 31) (Continued)

Item No.	Item	8 Hr/ 1 Day	250 Hr/ 6 Mo	500 Hr/ 6 Mo	1000 Hr/ 6 Mo	2000 Hr/ 1 Yr	4000 Hr/ 2 Yr	Procedure or Quantity	Specification
19	LPG FUEL INJECTOR VAPOR FILTER Mazda 2.0L and 2.2L Engines (Except 2007 Emission Compliant Engines)				C			1 Filter	See Parts Manual .
19	FUEL FILTER GM 2.4L Engines (LPG)				C			1 Filter	See Parts Manual .
19	FUEL FILTER Mazda 2.0L and 2.2L (Except 2007 Emission Compliant Engines) and GM 2.4L Engines (Gas)					C		1 Filter	See Parts Manual .
19	FUEL FILTER Mazda 2.0L and 2.2L Engines (2007 Emission Compliant Engines Only) (Gas)				C			1 Filter	See Parts Manual .
19	FUEL WATER SEPARATOR Yanmar 2.6L and 3.3L Engines (Diesel)				C			1 Filter	See Parts Manual .

X = Check C = Change L = Lubricate CIL = Check indicator light during operation

Table 8. (See Figure 18 Through Figure 31) (Continued)

Item No.	Item	8 Hr/ 1 Day	250 Hr/ 6 Mo	500 Hr/ 6 Mo	1000 Hr/ 6 Mo	2000 Hr/ 1 Yr	4000 Hr/ 2 Yr	Procedure or Quantity	Specification
19	IN-LINE FUEL FILTER Yanmar 2.6L and 3.3L Engines (Diesel)				C			1 Filter	See Parts Manual .
15	TIMING BELT							Replace. See NOTE 7.	See Parts Manual .
22	FUEL INJECTOR Mazda 2.0L and 2.2L Engines (LPG, Except 2007 Emission Compliant Engines)							1 Injector See NOTE 8.	Check and Clean if Required.
22	FUEL INJECTORS Mazda 2.0L and 2.2L Engines (Gas)							4 Injectors See NOTE 8.	Check and Replace if Required.
5	SPARK PLUGS Mazda 2.0L and 2.2L Engines (Gas/LPG)				C			Check Plug Wires. 4 Plugs	See Parts Manual . 0.8 ±0.1 mm (0.31 ±0.004 in.)
22	FUEL INJECTOR GM 2.4L Engines (Gas/LPG)					X		4 Injectors	Check and Replace if Required.

X = Check C = Change L = Lubricate CIL = Check indicator light during operation

Maintenance Schedule

HYSTER

Table 8. (See Figure 18 Through Figure 31) (Continued)

Item No.	Item	8 Hr/ 1 Day	250 Hr/ 6 Mo	500 Hr/ 6 Mo	1000 Hr/ 6 Mo	2000 Hr/ 1 Yr	4000 Hr/ 2 Yr	Procedure or Quantity	Specification
5	SPARK PLUGS GM 2.4L Engines (Gas/LPG)				C			Check Plug Wires. 4 Plugs	See Parts Manual . 0.8 to 0.9 mm (0.032 to 0.035 in.)
22	FUEL INJECTOR Yanmar 2.6L and 3.3L Engines (Diesel)					X		4 Injectors	Check and Replace if Required.
12,14	COOLING SYSTEM Mazda 2.0L and 2.2L Engines (Serpentine and Square Wave)	X CIL					C	11.0 liter (11.6 qt)	See NOTE 15.
12,14	COOLING SYSTEM Mazda 2.0L and 2.2L Engines (Square Wave with Air Oil Cooler)	X CIL					C	10.6 liter (11.2 qt)	See NOTE 15.
12,14	COOLING SYSTEM GM 2.4L Engines	X CIL					C	10.6 liter (11.2 qt)	See NOTE 15.
12,14	COOLING SYSTEM Yanmar 2.6L and 3.3L Engines	X CIL					C	11.5 liter (12.1 qt)	See NOTE 15.
	CLEAN DEBRIS FROM RADIATOR CORE			X				See NOTE 5.	

X = Check C = Change L = Lubricate CIL = Check indicator light during operation

Table 8. (See Figure 18 Through Figure 31) (Continued)

Item No.	Item	8 Hr/ 1 Day	250 Hr/ 6 Mo	500 Hr/ 6 Mo	1000 Hr/ 6 Mo	2000 Hr/ 1 Yr	4000 Hr/ 2 Yr	Procedure or Quantity	Specification
7	TRANSMISSION OIL Dry Brakes (Iron Case)			X		C		20 liter (21 qt)	John Deere JDM J20C See NOTE 17.
7	TRANSMISSION OIL Dry Brakes (Aluminum Case)			X		C		13 liter (14 qt)	John Deere JDM J20C See NOTE 17.
23	TRANSMISSION OIL FILTER					C		1 Filter See NOTE 4.	See Parts Manual .
28	FORKS	X		X		X		Check Condition.	
29	MAST Sliding Surfaces and Load Roller Surfaces			L				Lubricate as Required. See NOTE 11.	Multipurpose Grease See NOTE 9.
29	HEADER HOSES			X				Check Condition.	
30	LIFT CHAINS	X						Check Lubrication. See NOTE 12.	Engine Oil SAE 30W

X = Check C = Change L = Lubricate CIL = Check indicator light during operation

Maintenance Schedule

HYSTER

Table 8. (See Figure 18 Through Figure 31) (Continued)

Item No.	Item	8 Hr/ 1 Day	250 Hr/ 6 Mo	500 Hr/ 6 Mo	1000 Hr/ 6 Mo	2000 Hr/ 1 Yr	4000 Hr/ 2 Yr	Procedure or Quantity	Specification
30	LIFT CHAINS			L	L,X			Lubricate as Required. Check for Wear.	Engine Oil SAE 30W
	MAST Sideshift Carriage	X		L				Lubricate as Required. 2 Fittings	Multipurpose Grease See NOTE 9.
	INTEGRAL SIDESHIFT CARRIAGE Fork Positioner			L				Lubricate as Required. 2 fittings. See NOTE 5.	Multipurpose Grease See NOTE 9.
	MAST Pivots			L				2 Fittings	Multipurpose Grease See NOTE 9.
	MAST Integral Sideshift Carriage (Upper/Lower Bearings)			L	X	C		Lubricate As Required. 2 Fittings 4 Bearings	Multipurpose Grease See NOTE 9. 2.5 mm (3/32 in.)
	MAST Integral Sideshift Carriage Lower Mounting Hook				X			Check for Wear and Clearance. See NOTE 2 and NOTE 5.	0.76 mm (0.03 in.) Minimum Wear Limit.

X = Check C = Change L = Lubricate CIL = Check indicator light during operation

Table 8. (See Figure 18 Through Figure 31) (Continued)

Item No.	Item	8 Hr/ 1 Day	250 Hr/ 6 Mo	500 Hr/ 6 Mo	1000 Hr/ 6 Mo	2000 Hr/ 1 Yr	4000 Hr/ 2 Yr	Procedure or Quantity	Specification
	TILT CYLINDER ENDS			L				4 Fittings	Multipurpose Grease See NOTE 9.
	BRAKE MASTER CYLINDER ROD END PIN			L					SAE 10W-30 API SM ILSAC GF4 SAE J2362
	MANUAL HYDRAULIC HAND LEVERS			L					SAE 10W-30 API SM ILSAC GF4 SAE J2362
26	BRAKE FLUID Master Cylinder Dry Brakes	CIL		X		C		0.25 liter (0.53 pt)	SAE J-1703 (DOT 3)
26	BRAKE OIL Master Cylinder Wet Brakes	CIL		X		C		0.35 liter (0.74 pt)	Dexron III from Sealed Container
11	STEERING AXLE Tie Rod Ends H40-70FT (L177)			L				4 Fittings	Multipurpose Grease See NOTE 9.

X = Check C = Change L = Lubricate CIL = Check indicator light during operation

Maintenance Schedule

HYSTER

Table 8. (See Figure 18 Through Figure 31) (Continued)

Item No.	Item	8 Hr/ 1 Day	250 Hr/ 6 Mo	500 Hr/ 6 Mo	1000 Hr/ 6 Mo	2000 Hr/ 1 Yr	4000 Hr/ 2 Yr	Procedure or Quantity	Specification
11	STEERING AXLE King Pin H40-70FT (L177)				L			2 Fittings	Multipurpose Grease See NOTE 9.
11	STEERING AXLE Spindle Bearings S40-70FT, S55FTS (F187)				L			4 Fittings	Multipurpose Grease See NOTE 9.
2	PEDALS, LEVERS, SEAT RAILS, CABLES, HINGES, LINKAGES, HOOD LATCH				L			Lubricate as Necessary.	Hyster Part No. 328388
1	SERVICE BRAKES Dry Brakes					X		Check Lining Thickness.	1.0 mm (0.040 in.) Minimum Thickness
32	DIFFERENTIAL AND DRIVE AXLE OIL Dry Brakes S40-70FT, S55FTS (F187)			X		C		5.0 liter (5.3 qt)	SAE 80W-90, or 85W-140
32	DIFFERENTIAL AND DRIVE AXLE OIL Dry Brakes H40-70FT (L177)			X		C		6.5 liter (6.9 qt)	SAE 80W-90, or 85W-140

X = Check C = Change L = Lubricate CIL = Check indicator light during operation

Table 8. (See Figure 18 Through Figure 31) (Continued)

Item No.	Item	8 Hr/ 1 Day	250 Hr/ 6 Mo	500 Hr/ 6 Mo	1000 Hr/ 6 Mo	2000 Hr/ 1 Yr	4000 Hr/ 2 Yr	Procedure or Quantity	Specification
7	TRANSMISSION OIL Wet Brakes - Iron Case H40-70FT (L177)			X		C		20 liter (21 qt)	John Deere JDM J20C See NOTE 17.
7	TRANSMISSION OIL Wet Brakes - Aluminum Case H40-70FT (L177)			X		C		13 liter (14 qt)	John Deere JDM J20C See NOTE 17.
32	WET BRAKE AXLE PLANETARY HOUSING OIL, LEFT SIDE			X		C		0.5 liter (0.5 qt)	SAE 80W-90
32	WET BRAKE AXLE PLANETARY HOUSING OIL, RIGHT SIDE			X		C		2.0 liter (2.1 qt)	SAE 80W-90
32	WET BRAKE AXLE CENTER SECTION OIL			X		C		1.0 liter (1.1 qt)	John Deere JDM J20C
X = Check C = Change L = Lubricate CIL = Check indicator light during operation									

Table 8. (See Figure 18 Through Figure 31) (Continued)

Item No.	Item	8 Hr/ 1 Day	250 Hr/ 6 Mo	500 Hr/ 6 Mo	1000 Hr/ 6 Mo	2000 Hr/ 1 Yr	4000 Hr/ 2 Yr	Procedure or Quantity	Specification
NOTE 1: Check fuel system for leaks prior to any service or maintenance activity.									
NOTE 2: Heavy-duty or high-temperature operations require more frequent checks.									
NOTE 3: Heavy-duty or contaminated applications will require hydraulic oil change at 2000 hours.									
NOTE 4: Change engine oil and filter after the first 100 hours of operation. Change transmission oil filter after first 500 hours of operation.									
NOTE 5: Recommended service intervals are based on a normal application in a clean environment. Applications involving contaminated environments such as high levels of airborne debris (dust and waste paper); chemical or abrasive compounds; poor ground conditions; intensive usage at high performance levels; or other abnormal conditions will require more frequent servicing. At your request, your Hyster dealer will advise you of the appropriate service intervals based on an application survey.									
NOTE 6: In dirty or dusty environments, replace at 1000 hours or as needed.									
NOTE 7: Replace timing belt on Mazda engines every 3500 hours. Use only hour interval.									
NOTE 8: Check fuel injectors at 5000 hours or 7 years.									
NOTE 9: Multipurpose grease with 2 to 4% Molybdenum Disulfide.									
NOTE 10: Vehicles used in paper application require regular inspection and cleaning to minimize risk of fire. This should be done at least once every 8 hours or more frequently depending upon operating environment. Use compressed air and steam clean as necessary.									
NOTE 11: Lubricate mast every 3 months if unit has less than 1000 hours.									
NOTE 12: Lubricate at first sign of visible surface rust.									
X = Check C = Change L = Lubricate CIL = Check indicator light during operation									

Table 8. (See Figure 18 Through Figure 31) (Continued)

Item No.	Item	8 Hr/ 1 Day	250 Hr/ 6 Mo	500 Hr/ 6 Mo	1000 Hr/ 6 Mo	2000 Hr/ 1 Yr	4000 Hr/ 2 Yr	Procedure or Quantity	Specification
NOTE 13: Do not open the air filter canister except to change the air filter element. See the Periodic Maintenance Manual for your lift truck for the correct procedure to change air filter element.									
NOTE 14: Replace after 3000 hours. Use hour interval only.									
NOTE 15: Use Ethylene Glycol Boron-free Antifreeze. Purchase a pre-diluted 50/50 solution; or mix 50% concentrate with 50% distilled or deionized water.									
NOTE 16: Hydraulic oil sampling and analysis is a recommended practice. See Hydraulic Cleanliness Procedures 1900 SRM 1620 for oil cleanliness and water content guidelines. For lift trucks operating in heavy duty applications or highly contaminated environments, take oil samples every 500 hours. Normal operating conditions may allow for less frequent oil sampling. Oil sampling should be done just prior to all oil and filter changes.									
NOTE 17: If lift truck is used in Paper Application use ONLY JDM J20C type fluid for both the transmission and hydraulic system.									
X = Check C = Change L = Lubricate CIL = Check indicator light during operation									

Maintenance Procedures Every 8 Hours or Daily

How to Make Checks With the Engine Stopped

WARNING

Do not operate a lift truck that needs repairs. Report the need for repairs immediately. If repair is necessary, put a DO NOT OPERATE tag in the operator's area. If lift truck is equipped with a key switch, remove the key.

Put the lift truck on a level surface. Lower the carriage and forks, stop the engine, and apply the parking brake. Open the hood and check for leaks and conditions that are not

normal. Clean any oil or fuel spills. Ensure all surfaces are free of oils, lubricants, fuel and organic dust or fibers (paper, wood, cotton, agricultural grass/grain, etc.).

Tires and Wheels

Check the tires for damage (see **Figure 32**). Check the tread and remove any objects that will cause damage. Check for bent or damaged rims. Check for loose or missing hardware. Remove any wire, strapping, or other material that is wrapped around the axle.

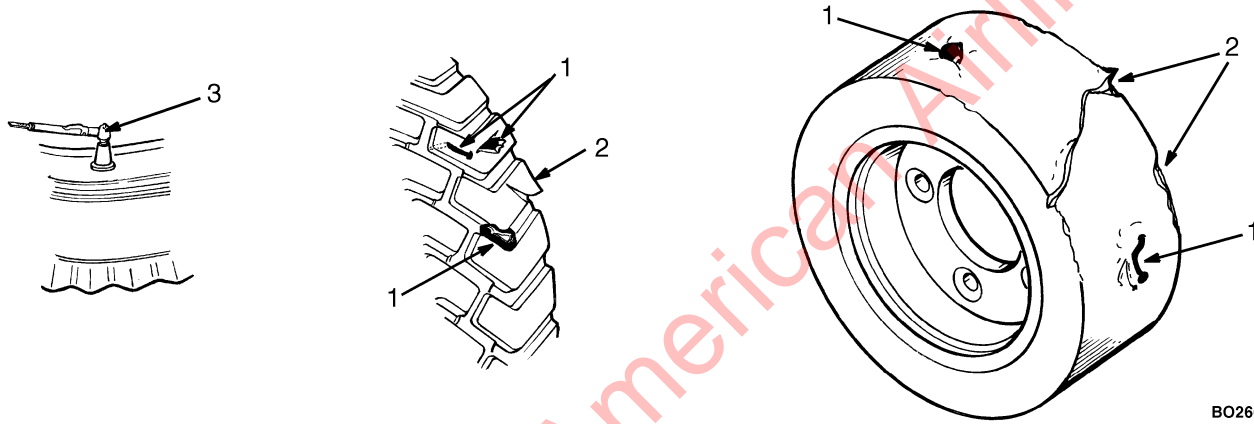

BO260053

1. CHECK FOR DAMAGE (REMOVE NAILS, GLASS AND OTHER OBJECTS FROM THE TREAD)
2. MAKE SMOOTH EDGES
3. CHECK THE TIRE PRESSURE (PNEUMATIC TIRES)

Figure 32. Check the Tires

Safety Labels

WARNING

Safety labels are installed on the lift truck to give information about operation and possible hazards. It is important that all safety labels are installed on the lift truck and can be read.

Check that all safety labels are installed in the correct location on the lift truck. See the **Parts Manual**, the **Model Description** section in this **Operating Manual**, or the **Frame** section of the **Service Manual** 100 SRM 1120 for the correct location of the safety labels. See the **Parts Manual** for the part numbers of the safety labels.

Mast, Carriage, Header Hoses, Lift Chains, and Attachment

(See Figure 47 and Figure 33)

WARNING

Lower the lift mechanism completely. Never allow any person under a raised carriage. Do not put any part of your body in or through the lift mechanism unless all parts of the mast are completely lowered and the engine is STOPPED.

Do not try to correct the alignment of the fork tips by bending the forks or adding shims. If either fork is damaged, replace the forks as a set.

Never repair damaged forks by heating or welding. Forks are made of special steel using special procedures. If either fork is damaged, replace the forks as a set.

1. Inspect the welds on the mast, cylinders, and carriage for cracks. Make sure that the capscrews and nuts are tight.
2. Inspect the channels for wear in the areas where the rollers travel. Inspect the rollers for wear or damage.
3. Inspect the load backrest extension for cracks and damage.
4. If the lift truck is equipped with a sideshift carriage or attachment, inspect the parts for cracks and wear. Make sure the parts that fasten the sideshift carriage or attachment to the carriage are in good condition.
5. Visually inspect hoses/fittings for hydraulic leaks; hose cover for cuts, cracks, or exposed reinforcement; defective/broken clamping devices or sheaves; and proper tracking

during operation. Adjust/repair/replace hose/components as necessary.

6. Check that the lift chains are correctly lubricated. Use SAE 30 engine oil to lubricate the lift chains.

7. Inspect the lift chains for cracks or broken links and worn or turned pins. Lift chains must be replaced as a set. See **Figure 33**.

8. Inspect the chain anchors and pins for cracks and damage.

9. Make sure the lift chains are adjusted so that they have equal tension. **Adjustments or replacement of the lift chains must be done by authorized personnel.**

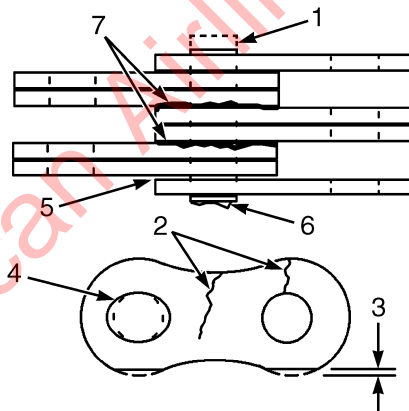

- | | | | |
|----|-----------|----|--------------|
| 1. | WORN PIN | 5. | LOOSE LEAVES |
| 2. | CRACKS | 6. | DAMAGED PIN |
| 3. | EDGE WEAR | 7. | CORROSION |
| 4. | HOLE WEAR | | |

BO190158

Figure 33. Lift Chain Check

Operator Restraint System

The seat belt, hip restraint, seat, hood, and hood latches are all part of the operator restraint system (see **Figure 34**)

Figure 35. Each item must be checked to make sure it is fastened correctly, functions correctly, and is in good condition.

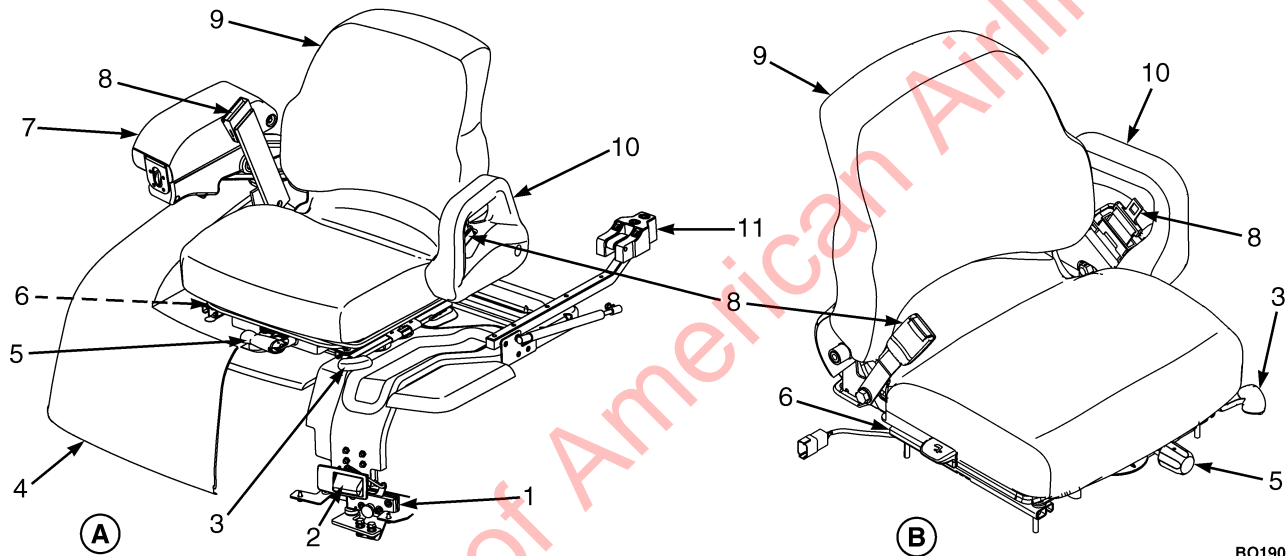

BO190176

Figure 34. Hood and Seat Check

Legend for Figure 34

NOTE: NON-SWIVEL SEAT SHOWN.

- A.** AUTOMATIC LOCKING RETRACTOR
1. LATCH STRIKER
 2. HOOD LATCH
 3. FORWARD/BACKWARD ADJUSTMENT
 4. HOOD
 5. OPERATOR WEIGHT ADJUSTMENT
 6. SEAT RAIL

- B.** EMERGENCY LOCKING RETRACTOR
7. ARM REST
 8. SEAT BELT
 9. SEAT
 10. HIP RESTRAINT
 11. HOOD HINGE

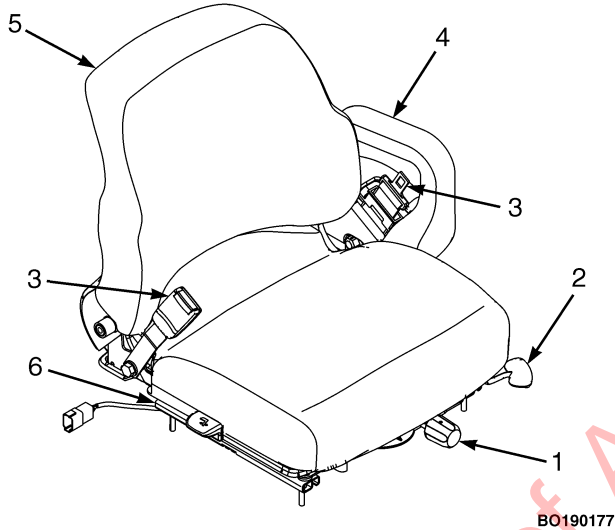

NOTE: NON-SWIVEL SEAT SHOWN.

- 1. OPERATOR WEIGHT ADJUSTMENT
- 2. FORWARD/BACKWARD ADJUSTMENT
- 3. SEAT BELT
- 4. HIP RESTRAINT
- 5. SEAT
- 6. SEAT RAIL

Figure 35. Hood and Seat Check

Automatic Locking Retractor (ALR)

NOTE: S40-70FT, S55FTS lift trucks produced before November 1, 2005 are equipped with the ALR type seat belts. See **Figure 36**.

The seat belt must fasten securely. Make sure the seat belt extends and retracts smoothly and is not frayed or torn. If the seat belt is damaged or does not operate properly, it must be replaced.

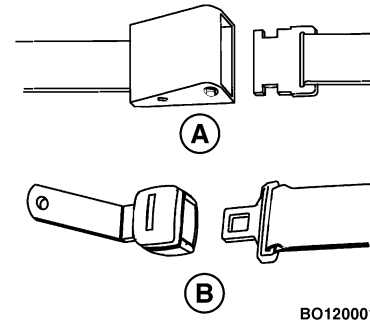

- A. AUTOMATIC LOCKING RETRACTOR (ALR)
- B. EMERGENCY LOCKING RETRACTOR (ELR)

Figure 36. Seat Belts

Emergency Locking Retractor (ELR)

When the ELR style seat belt is properly buckled across the operator, the belt will permit slight operator repositioning without activating the locking mechanism. If the truck tips over, travels off a dock, or comes to a sudden stop, the locking mechanism will be activated and hold the operator's lower torso in the seat. See **Figure 35** **Figure 34**.

A seat belt that is damaged, worn, or does not operate properly will not provide protection when it is needed. The end of the belt must fasten correctly in the latch. The seat belt must be in good condition. Replace the seat belt if it is damaged or worn.

NOTE: The following seat belt operation checks must be performed three times before replacing the seat belt assembly.

- With the hood closed and in the locked position, pull the seat belt slowly from the retractor assembly. Make sure the seat belt pulls out and retracts smoothly. If the seat belt does not pull out of the retractor assembly the internal latch may be locked. Pull firmly on the seat belt and hold for a moment to remove slack from the belt in the retractor. Release the seat belt. Seat belt will retract and the internal latch will unlock. If the seat belt cannot be

pulled from the retractor assembly or the belt will not retract, replace the seat belt assembly.

- With the hood closed and in the locked position, pull the seat belt with a sudden jerk. Make sure the seat belt will not pull from the retractor assembly. If the seat belt can be pulled from the retractor when it is pulled with a sudden jerk, replace the seat belt assembly.
- With the hood in the open position, make sure the seat belt will not pull from the retractor assembly. If the seat belt can be pulled from the retractor, with the hood in the open position, replace the seat belt assembly.

Hood and Seat Latches

Make sure the seat rails and latch striker are not loose. The seat rails must lock tightly in position, but move freely when unlocked (see **Figure 34** **Figure 35** and **Figure 37** **Figure 38**). The seat rails must be correctly fastened to the hood and the hood fastened to the hinges on the frame. Try to lift the hood to make sure it is fastened correctly and will not move. If adjustment is required, go to Hood Latch Check in the **Periodic Maintenance** section of the service manual.

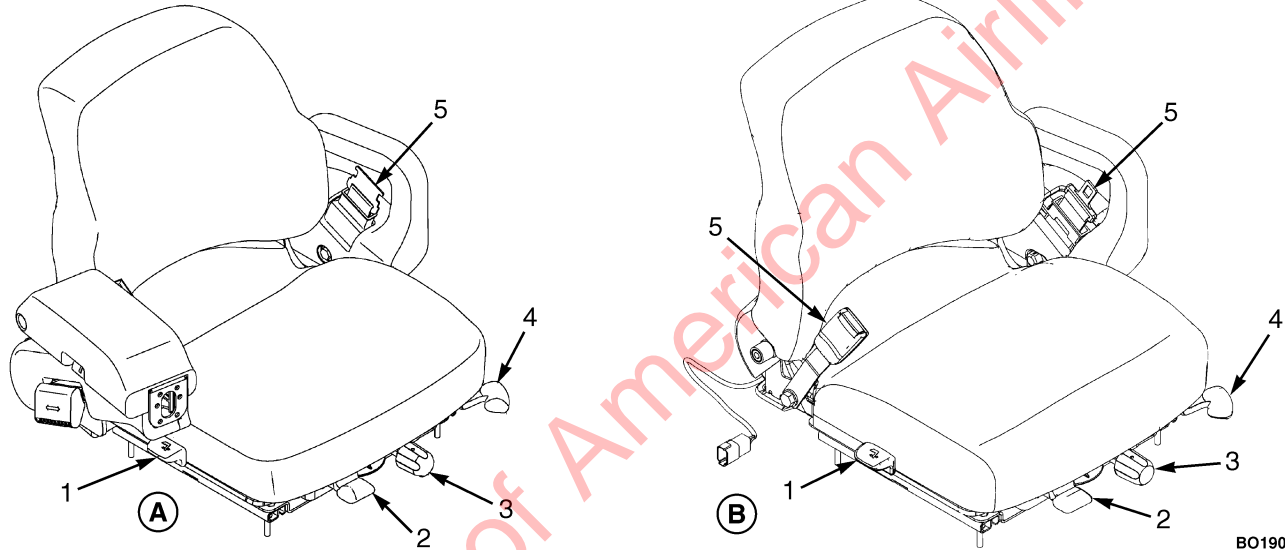

BO190175

NOTE: SWIVEL SEAT IS AN OPTIONAL FEATURE.

A. AUTOMATIC LOCKING RETRACTOR

B. EMERGENCY LOCKING RETRACTOR

- | | | |
|--------------------------------|---|--------------|
| 1. FORWARD/BACKWARD ADJUSTMENT | 3. OPERATOR WEIGHT ADJUSTMENT | 5. SEAT BELT |
| 2. SWIVEL ADJUSTMENT | 4. SEAT POSITION ADJUSTMENT (SEAT RAIL) | |

Figure 37. Swivel Seat Controls

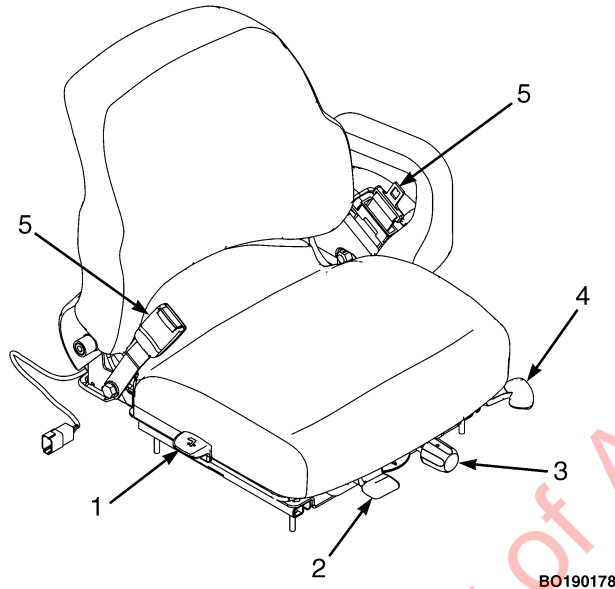

NOTE: SWIVEL SEAT IS AN OPTIONAL FEATURE.

1. FORWARD/BACKWARD ADJUSTMENT
2. SWIVEL ADJUSTMENT
3. OPERATOR WEIGHT ADJUSTMENT
4. SEAT POSITION ADJUSTMENT (SEAT RAIL)
5. SEAT BELT

Figure 38. Swivel Seat Controls

Engine Compartment

Check for the presence of any combustibile material such as paper, leaves etc. Remove any combustibile materials.

Paper Application

Vehicles used in paper applications require regular inspection and cleaning to minimize the risk of fire. This should be done at least once every 8 hours or more frequently depending upon operating environment. The paper application will help limit the contact of paper or tissue scraps to hot surfaces under the hood, but frequent maintenance is required.

⚠ WARNING

Engine and exhaust system components are hot to the touch. Be sure lift truck components are cool before starting inspection and cleaning, or personal injury may occur.

Ensure the truck engine cools properly by allowing it to idle for several minutes. Shutting the truck down while hot will not allow the engine to cool quickly due to the loss of coolant circulation. The heat trapped under the hood may

actually increase the engine temperature because of no heat transfer through the radiator.

With engine **OFF** and lift truck components cooled, check and clean the radiator and if equipped, radiator screen. Check engine manifold, exhaust pipes, muffler, and catalytic converter for paper scraps. Clean as required. Check and clean the engine compartment components, transmission, fan shroud, belly pan, if equipped, and inside frame ledges to avoid paper, dust, and oil accumulation. Check axle and cowl openings for paper buildup and bailing wire. Remove any debris.

WARNING

Compressed air can move particles so that they cause injury to the user or to other personnel. Make sure that the path of the compressed air is away from all personnel. Wear protective goggles or a face shield to prevent injury to the eyes.

CAUTION

Air pressure, nozzle, or extension tube may cause damage to exhaust wraps and radiator fins. Assure that air pressure, nozzle, or extension tube does not damage exhaust wraps or radiator fins.

Paper removal can generally be accomplished using a compressed air line and nozzle. An extension may be helpful to access hard to reach places. Remove floor plates and side covers for better access to engine compartment. Open or remove belly pan, if equipped. Clean components with compressed air. Take care to maintain the integrity of the exhaust wraps when cleaning with compressed air and use caution to not force debris into openings.

WARNING

Be careful when cleaning with steam. Steam can cause serious burns. Wear protective clothing, gloves, and eye protection. Never expose your skin to steam.

If compressed air did not adequately remove debris, steam clean to remove any persistent accumulation of material or oil. Protect electrical components from moisture when steam cleaning. Do not spray exhaust wraps directly with high pressure steam. Allow lift truck to air dry before returning to work in a contaminated environment. Paper dust and scraps will adhere to wet surfaces.

Check the condition of exhaust wraps for wear, proper fit, contamination with oil or antifreeze, gaps in coverage, and failed fasteners. Replace as necessary. Do not reuse

wraps if they have been removed for some other service operation.

Fuel, Oil, and Coolant Leaks, Check

WARNING

All fuels are very flammable and can burn or cause an explosion. Do not use an open flame to check the fuel level or to check for leaks in the fuel system. If there is a leak in the fuel system, extra care must be used during the repair. Do not operate the lift truck until a leak is repaired.

Make a visual check for leaks on and under the lift truck. If possible, find and report the leak to maintenance for repair. Leaks often indicate a need for repair of damaged or worn components. Leaks in the LPG fuel system are usually not visible unless ice is present. There is however, usually a strong odor. Fuel leaks **MUST** be repaired **IMMEDIATELY**.

Check the fuel system for leaks and the condition of parts. When fuel is added to the lift truck, see the section, **How to Add Fuel to the Lift Truck**.

Also check the condition of the radiator or heater hoses that are not leaking. Soft or cracked hoses need to be replaced before a major leak occurs.

Hydraulic Hoses

Check the condition of the hydraulic hoses for serviceability by inspecting for cracks or other obvious damage. Check to insure that the hydraulic hoses are not leaking. If any hose is leaking, report it to maintenance for repair.

Coolant Hoses

Check the condition of the coolant hoses for serviceability by inspecting for cracks or other obvious damage. Check to insure that the coolant hoses are not leaking. If any hose is leaking, report it to maintenance for repair.

Steering Column Gas Cylinder

Make sure the gas cylinder for the steering column operates correctly. The cylinder must NOT allow the column to move unless the tilt lever is released. See **Figure 39**.

Transmission

Check the transmission for leaks, damage, and loose components.

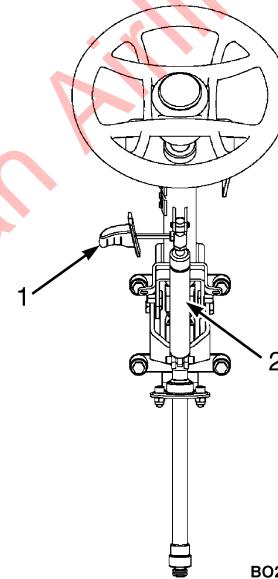

1. TILT LEVER

2. GAS CYLINDER

Figure 39. Steering Column Gas Cylinder and Tilt Lever

Hydraulic System Oil

WARNING

At operating temperature the hydraulic oil is **HOT**. Do not permit the hot oil to touch the skin and cause a burn.

CAUTION

Do not permit dirt to enter the hydraulic system when the oil level is checked or the filter is changed.

Never operate the hydraulic pump without oil in the hydraulic system. The operation of the hydraulic pump without oil will damage the pump.

Check the hydraulic system for leaks and damaged or loose components. Heavy-duty or high-temperature operations can require more frequent checks.

Engine Oil

After the engine has stopped, wait one minute before checking the oil level. See **Figure 40**, **Figure 41**, **Figure 42**, or **Figure 43**. Keep the oil at the correct level as indicated on the dipstick. Use the correct oil as shown in the **Maintenance Schedule**.

There is an indicator light for the engine oil pressure on the Display Switch Cluster. During normal operation the red indicator light will illuminate when the key switch is turned to **ON**, if the truck is equipped with a key switch, or when the power **ON/OFF** button is pressed, if the truck is equipped with a keyless option, and will stay illuminated until correct oil pressure is obtained, at which time the light will go off.

If the light continues to stay on when the engine is running, the engine oil pressure is low. Stop the engine and check the oil level. See **Figure 40**, **Figure 41**, **Figure 42**, or **Figure 43**. Do not restart the engine until the low pressure condition has been corrected.

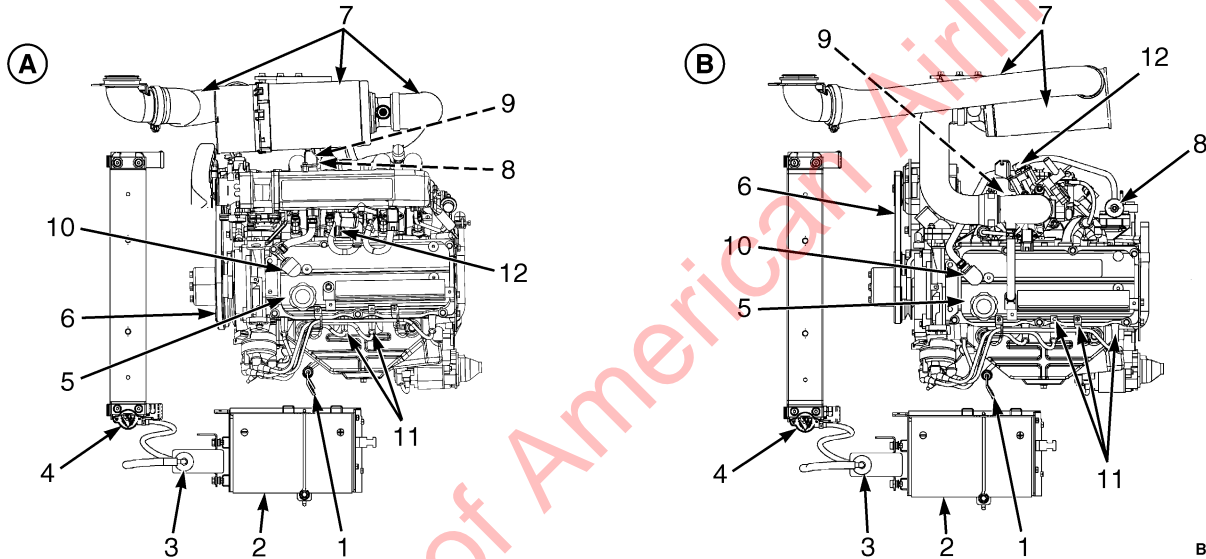

BO190043

A. GAS ENGINE

- 1. DIPSTICK ENGINE OIL
- 2. BATTERY
- 3. AUXILIARY COOLANT RESERVOIR
- 4. RADIATOR CAP

B. LPG ENGINE

- 5. ENGINE OIL FILL
- 6. DRIVE BELT
- 7. AIR FILTER
- 8. FUEL FILTER

- 9. ENGINE OIL FILTER
- 10. PCV VALVE
- 11. SPARK PLUGS
- 12. FUEL INJECTOR

Figure 40. Mazda 2.0L and 2.2L Engine Maintenance Points (Except 2007 Emission Compliant Engines)

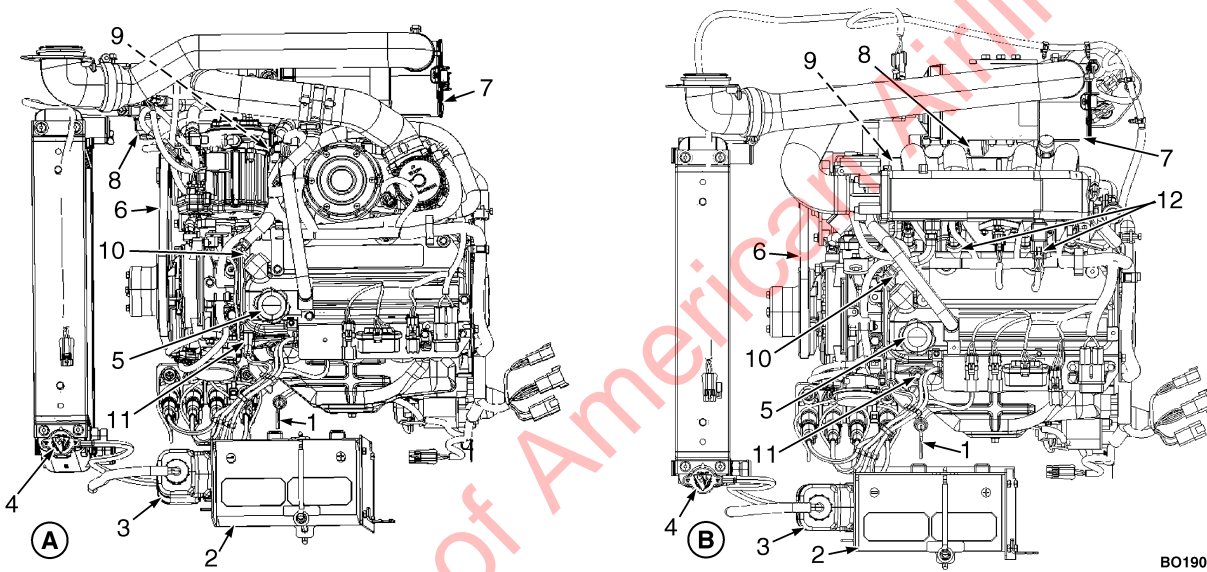

BO190300

A. LPG ENGINE

- 1. DIPSTICK ENGINE OIL
- 2. BATTERY
- 3. AUXILIARY COOLANT RESERVOIR
- 4. RADIATOR CAP

B. GAS ENGINE

- 5. ENGINE OIL FILL
- 6. DRIVE BELT
- 7. AIR FILTER
- 8. FUEL FILTER

- 9. ENGINE OIL FILTER
- 10. PCV VALVE
- 11. SPARK PLUGS
- 12. FUEL INJECTOR (GAS ONLY)

Figure 41. Mazda 2.0L and 2.2L Engine Maintenance Points (2007 Emission Compliant Engines Only)

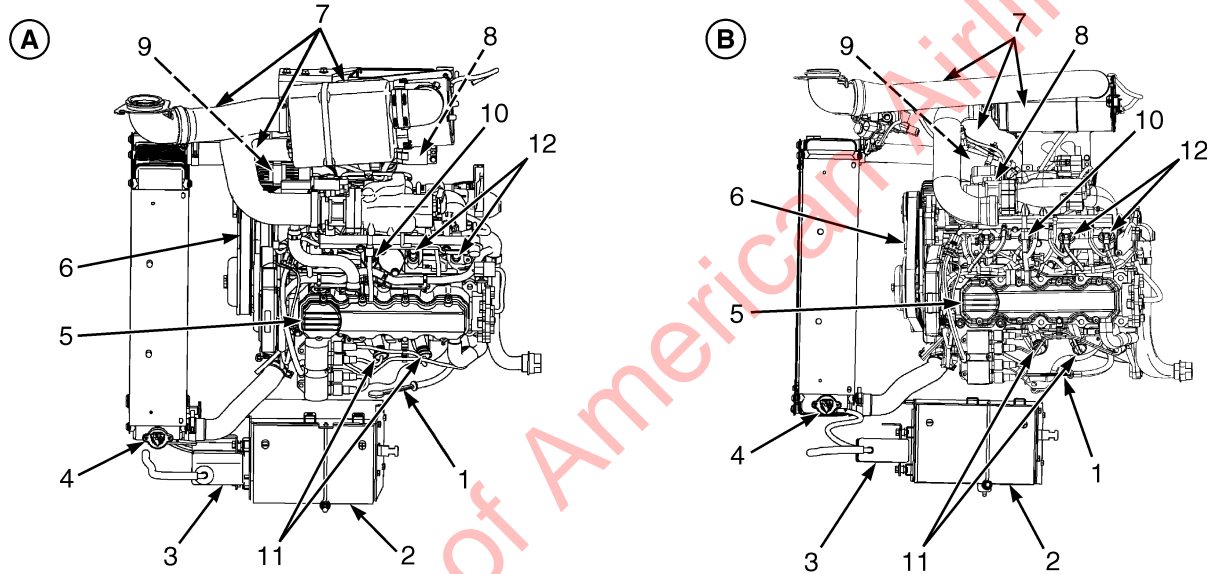

BO190044

A. GAS ENGINE

B. LPG ENGINE

- 1. DIPSTICK ENGINE OIL
- 2. BATTERY
- 3. AUXILIARY COOLANT RESERVOIR

- 4. RADIATOR CAP
- 5. ENGINE OIL FILL
- 6. DRIVE BELT

- 7. AIR FILTER
- 8. FUEL FILTER
- 9. ENGINE OIL FILTER

- 10. PCV VALVE
- 11. SPARK PLUGS
- 12. FUEL INJECTOR

Figure 42. GM Engine Maintenance Points

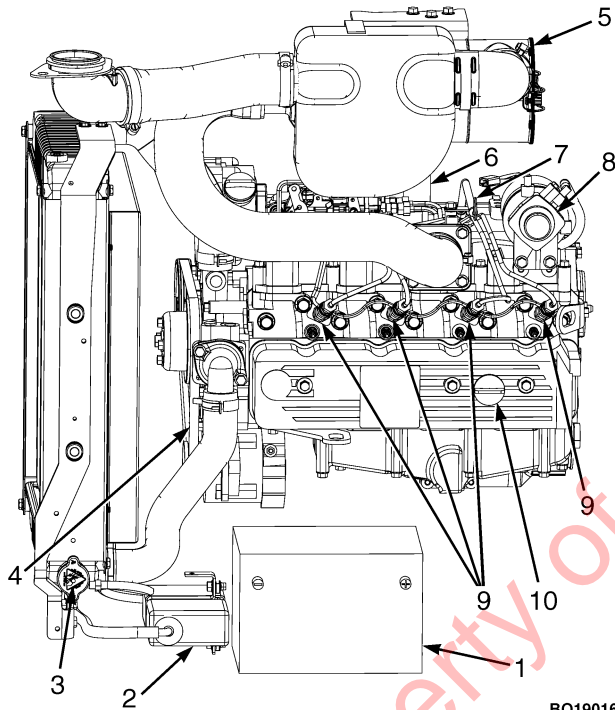

1. BATTERY
2. AUXILIARY COOLANT RESERVOIR
3. RADIATOR CAP
4. DRIVE BELT
5. AIR FILTER
6. ENGINE OIL FILTER
7. DIPSTICK ENGINE OIL
8. FUEL FILTER
9. FUEL INJECTOR
10. ENGINE OIL FILL

BO190167

Figure 43. Yanmar 2.6L and 3.3L and 3.3L Diesel Engine Maintenance Points

Air Filter

The air filter canister should not be opened until an air filter element replacement is required. An air filter element replacement is required when one of the following occurs:

- the optional air flow restriction indicator light on the dash illuminates
- the optional manual air flow indicator button pops up
- the specified number of hours has passed since the last filter element replacement

Do not operate the lift truck until the air filter element has been replaced.

Forks

NOTE: Forks must be removed or installed by trained personnel only.

The identification of a fork describes how the fork is connected to the carriage. These lift trucks have hook forks.

Forks, Remove

NOTE: If lift truck is equipped with a fork positioner attachment, perform **Step 1** first, before going to **Step 2**. If lift truck is not equipped with a fork positioner attachment, go to **Step 2**.

1. Lower the carriage and remove four capscrews from inner fork carriers. Remove inner fork carriers from fork positioner. See **Figure 44**.

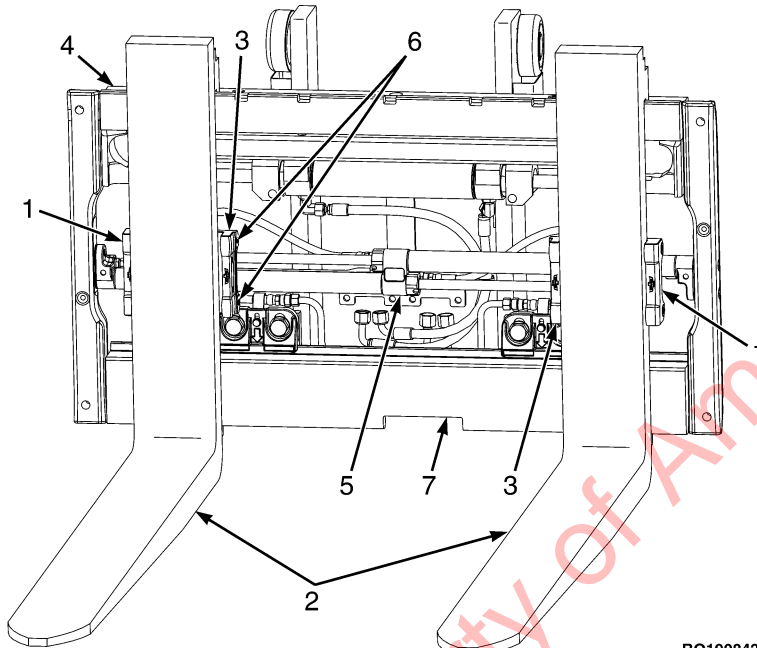

- 1. OUTER FORK CARRIER
- 2. FORKS
- 3. INNER FORK CARRIER
- 4. SIDESHIFT CARRIAGE
- 5. FORK POSITIONER
- 6. CAPSCREWS
- 7. FORK REMOVAL NOTCH

BO190843

Figure 44. Fork Positioner

⚠ WARNING

Do not try to move a fork without a lifting device. Each hook fork for these lift trucks can weigh 45 to 115 kg (99 to 253 lb).

NOTE: Forks are to be replaced only in sets and not individually.

2. A fork can be removed from the carriage for replacement of the fork or other maintenance. Slide a hook fork to the fork removal notch on the carriage. See **Figure 45** and **Figure 47**. Lower the fork onto blocks so that the bottom hook of the fork moves through the fork removal notch. See **Figure 47**. Lower the carriage further so that the top hook of the fork is disengaged from the top carriage bar. Move the carriage away from the fork, or use a lifting device to move the fork away from the carriage. See **Figure 46**.

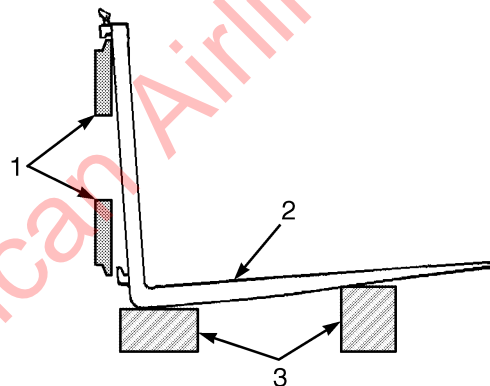

BO190156

1. CARRIAGE BARS
2. HOOK FORK
3. BLOCKS

Figure 45. Remove a Hook Fork

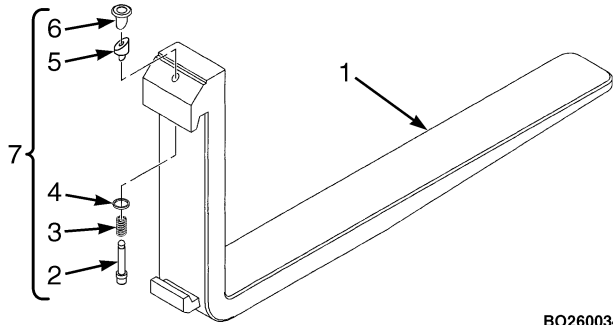

BO260034

1. FORK
2. LOCK PIN
3. SPRING
4. WASHER
5. WEDGE
6. KNOB
7. LOCK PIN ASSEMBLY

Figure 46. Fork Lock Pin Assembly

Forks, Inspect

1. Inspect the forks for cracks and wear. Check that the fork tips are aligned as shown in **Figure 47**. Check that the bottom of the fork is not worn (Item 4 in **Figure 47**).
2. Replace any damaged or broken parts that are used to keep the forks locked in position.

Forks, Install

1. Move the fork and carriage so that the top hook on the fork can engage the upper carriage bar. Raise the carriage to move the lower hook through the fork removal notch. Slide the fork on the carriage so that both upper and lower hooks engage the carriage. Engage the lock pin with a notch in the upper carriage bar. See **Figure 46**.
2. If lift truck is equipped with a fork positioner, install inner fork carriers using four capscrews. Tighten capscrews to 35 N•m (25 lbf ft). See **Figure 44**.

Forks, Adjust

NOTE: During the adjustment of the forks, the heel of the forks should not be touching the ground.

The forks are connected to the carriage by hooks and lock pins. See **Figure 45** and **Figure 46**. The lock pins are installed through the top fork hooks and fit into slots in the top carriage bar. If pin does not remain engaged in carriage

slot, replace with new pin. Adjust the forks as far apart as possible for maximum support of the load. Hook forks will slide along the carriage bars to adjust for the load to be lifted. Raise the lock pin in each fork to slide the fork on the carriage bar. Make sure the lock pin is engaged in the carriage bar to lock the fork in position after the width adjustment is made.

Property of American Forklifts

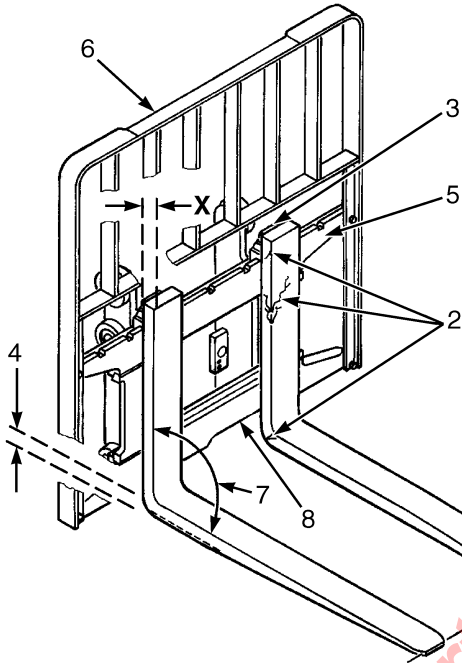

Fork Tip Alignment	
Length of Forks	3% Dimension
915 mm (36 in)	27 mm (1.10 in)
1067 mm (42 in)	32 mm (1.26 in)
1220 mm (48 in)	37 mm (1.46 in)
1372 mm (54 in)	41 mm (1.61 in)
1524 mm (60 in)	46 mm (1.81 in)
1830 mm (72 in)	55 mm (2.17 in)

1. TIP ALIGNMENT (MUST BE WITHIN 3% OF FORK LENGTH)
2. CRACKS
3. LATCH DAMAGE
4. HEEL OF FORK (MUST BE 90% OF DIMENSION "X")
5. CARRIAGE
6. LOAD BACKREST EXTENSION
7. MAXIMUM ANGLE 93°
8. FORK REMOVAL NOTCH

BO190157

Figure 47. Forks Check

How to Make Checks With the Engine Running

WARNING

DO NOT operate a lift truck that needs repairs. Report the need for repair immediately. If repair is necessary, put a **DO NOT OPERATE** tag in the operator's area. If lift truck is equipped with a key switch, remove the key.

WARNING

FASTEN YOUR SEAT BELT! The seat belt is installed to help the operator stay on the truck if the lift truck tips over. **IT CAN ONLY HELP IF IT IS FASTENED.**

Make sure that the area around the lift truck is clear before starting the engine or making any checks of the operation. Be careful when making the checks. If the lift truck is sta-

tionary during a check, apply the parking brake and put the transmission in **NEUTRAL**. Make the checks carefully.

Indicator Lights, Horn, Fuses, and Relays

If lift truck is equipped with a key switch, turn key to **ON** position. If lift truck is equipped with a Power **ON/OFF** button, press button to turn system power on. Check all indicator lights for correct operation as described in **Table 4**. Check the operation of the horn. Start the engine by turning the key switch to the **START** position, if truck is equipped with a key switch, or press the engine start button, if truck is equipped with this button. If any of the indicator lights do not operate correctly, stop the engine and check the fuses. The fuses are located in the Power Distribution Module (PDM) which is under the hood next to the battery on the right side. See **Figure 48**.

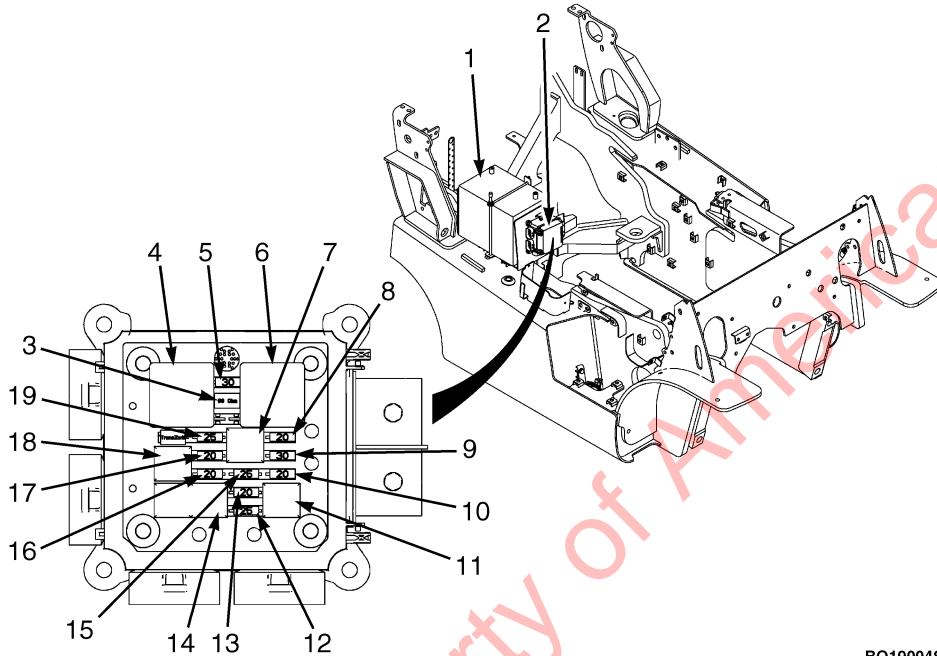

NOTE: HOOD REMOVED FOR CLARITY.

1. BATTERY
2. POWER DISTRIBUTION MODULE (PDM)
3. RESISTOR (68 OHM)
4. START RELAY
5. STARTER (30 AMP FUSE)
6. IGNITION 3 RELAY
7. BACKUP RELAY
8. BACKUP (20 AMP FUSE)
9. IGNITION (30 AMP FUSE)
10. SPARE FUEL PUMP (20 AMP FUSE)
11. SPARE FUEL PUMP RELAY
12. BATTERY (25 AMP FUSE)
13. FRONT WORK LIGHT (20 AMP FUSE)
14. FRONT/REAR WORK LIGHT RELAYS
15. BATTERY (25 AMP FUSE)
16. REAR WORK LIGHT (20 AMP FUSE)
17. IGNITION 1 (20 AMP FUSE)
18. IGNITION RELAY
19. BATTERY (25 AMP FUSE)

BO190048

Figure 48. PDM Showing Fuses and Relays

Service Brakes

Brake Fluid Level

WARNING

Small amounts of water in the brake system can cause reduced braking performance if the water reaches the wheel cylinder area. Do not allow water entry, ensure that the sealed reservoir lid is properly replaced.

If the brake system has a power assist (or boost), braking will be more difficult if the engine is not running.

On lift trucks with wet brake drive axles, only use Dexron III oil from sealed container in the master cylinder.

On lift trucks with dry brake drive axles, only use SAE J-1703 (DOT 3) brake fluid in the master cylinder.

Loss of fluid from the brake fluid reservoir indicates a leak. Repair the brake system before using the lift truck. Replace the brake fluid in the system if there is dirt or water in the system.

Failure to observe the above warnings could result in death or serious injury.

There is an indicator light on the Display Switch Cluster for the brake fluid. The red light is **ON** when the key switch is in the **START** position or the Power **ON/OFF** button is pressed, and must go **OFF** when the engine is running. If the light is **ON** when the engine is running, the brake fluid level in the reservoir is too low.

Operation, Check

Check the operation of the service brakes. Push on the inching/brake pedal. The service brakes must be applied before the inching/brake pedal reaches the floor plate. The pedal must stop firmly and must not move slowly down after the brakes are applied. The service brakes must apply equally to both drive wheels. The service brakes must not pull the lift truck to either side of the direction of travel when they are applied. The service brakes are automatically adjusted when the transmission is in reverse and the lift truck is moving and the brakes are firmly applied. Full application of the inching/brake pedal applies the service brakes and puts the transmission in **NEUTRAL**.

Lift trucks with a pedal: when the inching/brake pedal is fully applied, the engine can be started.

Parking Brake

Make sure the service brakes are adjusted and the operation of the automatic adjuster mechanism is correct before the parking brake is adjusted.

Lift trucks with a pedal:

A switch energizes the seat warning circuit when the hand lever is released. This switch puts the transmission in **NEUTRAL** by de-energizing the direction solenoid. There is also a switch on the left-hand side of bracket. This switch prevents engine from starting unless parking brake is applied.

NOTE: Make sure parking brake is released before making adjustment.

To adjust the parking brake, do the following:

1. Turn the adjustment knob as shown in **Figure 49**. Do not tighten the adjustment so that the brake is applied when the lever is released. The lever for the parking brake has a lock. Use your thumb or finger to release the lock on the lever when the parking brake is released.
2. For burnished brakes, test the operation of the parking brake. The lift truck, with a capacity load, must not move when parking brake is applied on a 15% grade. A 15%

grade is a slope that increases 1.5 m in 10 m (1.5 ft increase in 10 ft).

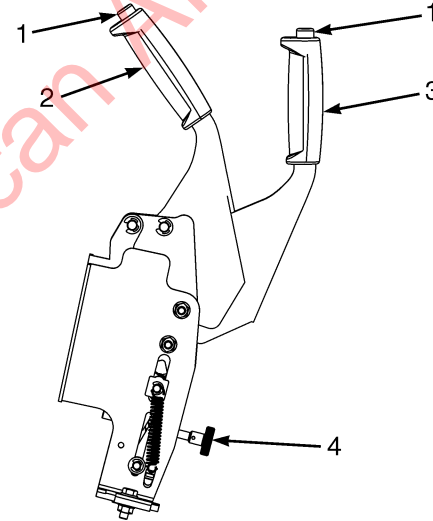

1. LOCK BUTTON RELEASE
2. OFF POSITION
3. ON POSITION
4. ADJUSTMENT KNOB

BO190049

Figure 49. Parking Brake Adjustment

Engine Oil Pressure

NOTE: The engine will enter shutdown mode after a warning buzzer sounds and a 30-second countdown if engine oil pressure is less than 34.5 kPa (5 psi) on lift trucks with powertrain protection system. Lift trucks equipped with a Yanmar diesel engine will enter shutdown mode when the engine oil pressure is less than 49 kPa (7 psi) on lift trucks with powertrain protection system. See the **Engine Shutdown** procedures in the **Operating Procedures** section in this manual.

There is an indicator light for the engine oil pressure on the Display Switch Cluster. During normal operation the red indicator light will illuminate when the key switch is turned to **ON**, if the truck is equipped with a key switch, or when the power **ON/OFF** button is pressed, if the truck is equipped with a keyless option, and will stay illuminated until correct minimum oil pressure is obtained, at which time the light will go off. If the light continues to stay on when the engine is running, the engine oil pressure is low. Stop the engine and check the oil level. See **Figure 40**, **Figure 41**, **Figure 42** or **Figure 43**. Do not restart the engine until the low pressure condition has been corrected.

Cooling System

WARNING

DO NOT remove the radiator cap from the radiator when the engine is hot. When the radiator cap is removed, the pressure is released from the system. If the system is hot, the steam and boiling coolant can cause burns.

NOTE: The engine will enter shutdown mode after a warning buzzer sounds and a 30-second countdown if coolant temperature reaches 121 °C (250 °F) or above, on lift trucks with powertrain protection system. Lift trucks equipped with a Yanmar diesel engine will enter the shutdown mode when the coolant temperature reaches 110 °C (230 °F) or above on lift trucks with powertrain protection system. See the **Engine Shutdown** procedures in the **Operating Procedures** section in this manual.

There is an indicator light on the Display Switch Cluster for the coolant temperature. The red light is **ON** when the key switch is in the **START** position or the Power **ON/OFF** button is pressed, and must go **OFF** when the engine is running. If the light is **ON** when the engine is running, the coolant and engine are too hot. Stop the engine and check

Maintenance

HYSTER

the coolant level in the coolant recovery reservoir and radiator.

Make sure the coolant level is between the **ADD** and **FULL** marks on the auxiliary coolant reservoir (See **Figure 50**). The coolant will expand as it is heated and the level in the auxiliary coolant reservoir will increase.

CAUTION

Additives may damage the cooling system. Before using additives, contact your local Hyster dealer.

If coolant is added, use the correct mixture of water and ethylene glycol shown in the **Maintenance Schedule**.

WARNING

Compressed air can move particles so that they cause injury to the user or to other personnel. Make sure that the path of the compressed air is away from all personnel. Wear protective goggles or a face shield to prevent injury to the eyes.

With the engine off, check the radiator fins. Clean the radiator with compressed air or water as needed.

Check for and remove any debris on the radiator core. If the indicator light turns on again after restarting, shut down the lift truck and do not operate the lift truck until the problem is corrected.

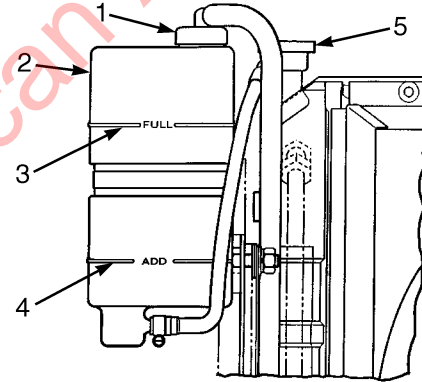

BO190159

- | | |
|--------------------------------|-----------------|
| 1. FILL CAP | 4. ADD MARK |
| 2. AUXILIARY COOLANT RESERVOIR | 5. RADIATOR CAP |
| 3. FULL MARK | |

Figure 50. Auxiliary Coolant Reservoir

Steering System

WARNING

The lift truck has hydraulic power steering. The steering can be difficult if the engine is not running.

Make sure the steering system operates smoothly and provides good steering control. Make sure the steering column can be adjusted and the gas cylinder function is correct.

Control Levers and Pedals

Check that the control levers for the transmission, mast, and attachment operate as described in **Table 4**. Check that the pedals operate correctly as described in **Table 4**.

Lift System Operation

WARNING

When working on or near the mast, see **Safety Procedures When Working Near the Mast in the Periodic Maintenance** for your lift truck.

Lower the lift mechanism completely. Never allow any person under a raised carriage. Do not put any part of your body in or through the lift mechanism unless all

parts of the mast are completely lowered and the engine is STOPPED.

If the mast cannot be lowered, use chains on the mast weldments and carriage so that they can not move. Make sure the moving parts are attached to a part that does not move. See the **Periodic Maintenance** section of the service manual for additional information.

Do not try to find hydraulic leaks by putting hands on pressurized hydraulic components. Hydraulic oil can be injected into the body by the pressure.

Perform the following checks and inspections:

1. With engine turned **OFF**, check for leaks in the hydraulic system. Check the condition of the hydraulic hoses and tubes.

NOTE: Some parts of the mast move at different speeds during raising and lowering.

2. Slowly raise and lower the mast several times without a load. Raise the mast to its full height at least once. The mast components must raise and lower smoothly in the correct sequence. Hose must track properly during operation.

3. The inner weldments and the carriage must lower completely.
4. Raise the mast 1 m (3 ft) with a capacity load. The inner weldments and the carriage must raise smoothly. Lower the mast. All moving components must lower smoothly.
5. Lower the load to approximately 0.3 m (1 ft). Tilt the mast forward and backward. The mast must tilt smoothly and both tilt cylinders must stop evenly.
6. Check that the controls for the attachment operate the functions of the attachment. See the symbols by each of the controls. Make sure all of the hydraulic lines are connected correctly and do not leak.

How to Add Fuel to the Lift Truck

WARNING

Use only 85 octane unleaded gasoline.

Stop the engine. Turn the key switch to OFF, if truck is equipped with a key switch; or press the Power

ON/OFF button, if truck is equipped with keyless start option. The operator must be off of the lift truck while fuel is added.

No smoking.

All fuels for internal combustion engines are very flammable.

Fill the fuel tank only in a designated area with good ventilation. Have a fire extinguisher available.

Never fill the fuel tank near an open flame or near equipment that can create sparks. Never check fuel level or check for leaks with an open flame.

Breathing fuel vapor may cause nausea, unconsciousness or death. Long-term exposure to gasoline vapors may cause liver or kidney damage and cancer. Avoid breathing vapor.

Liquefied Petroleum Gas (LPG)

WARNING

Close the fuel valve on the tank when the lift truck is not in active use. Do not park the lift truck near heat or ignition sources.

Do not store LPG tanks near heat or an open flame. For complete instructions on the storage of LPG fuels and the refueling of LPG tanks, refer to NFPA 58 & 505.

LPG is extremely flammable. When checking or filling an LPG tank: No smoking. Stop engine.

Frost on the surface of the tank, the valves or fittings and the odor of LPG fuel indicates a leak. Inspect the LPG system and repair a leak immediately. An LPG fuel leak creates an explosion and fire hazard. Do not attempt to start the engine if there is a leak in the LPG fuel system.

Only trained and authorized personnel are permitted to operate filling equipment.

Use only the LPG tank indicated on the label on the tank bracket. Do not use an LPG tank that is damaged. A damaged LPG tank must be removed from service.

WARNING

LPG tanks are heavy. The weight of an LPG tank can exceed the maximum recommended weight for safe lifting by an individual. Get assistance when lifting or lowering an LPG tank. Use correct lifting procedures.

LPG can cause an explosion. Do not cause sparks or permit flammable material near the LPG system. LPG fuel systems can be disconnected indoors only if the lift truck is at least 8 m (26 ft) from any open flame, motor vehicles, electrical equipments, or ignition source.

Removable LPG tanks must be removed from the fork lift before filling. If the lift truck is equipped with a non-removable LPG tank, make sure all components (engine, transmission, muffler, catalytic muffler) have surface temperatures that have cooled to below 427 °C (800 °F).

LPG Tank, Remove

NOTE: The LPG tank bracket used on this line of trucks to mount the LPG tank onto the counterweight comes in two styles. One style of bracket swings out to the side of the truck and the other swings out to the side and drops down . See **Figure 51**.

1. Removable LPG tanks can be replaced indoors only if the lift truck is a minimum of 8 m (26 ft) from any open flame, motor vehicles, electrical equipment, or ignition source. Move lift truck to an area where LPG tanks are changed.
2. Turn the shutoff valve clockwise until the valve is completely closed.

3. Run the engine until it stops, then turn the key switch to the **OFF** position if truck is equipped with key switch, or press the Power **ON/OFF** button if truck is equipped with keyless start option.

4. Disconnect the quick-disconnect fitting on the LPG tank. See **Figure 51**.

5. Push in the bracket release pin, grab the bracket handle, and swing the tank and bracket out to the side of the lift truck. If your truck is equipped with a swing out and drop down LPG tank bracket , drop the tank down to the side of the truck for ease of removal.

6. Unlatch the tank strap and remove the LPG tank from the bracket.

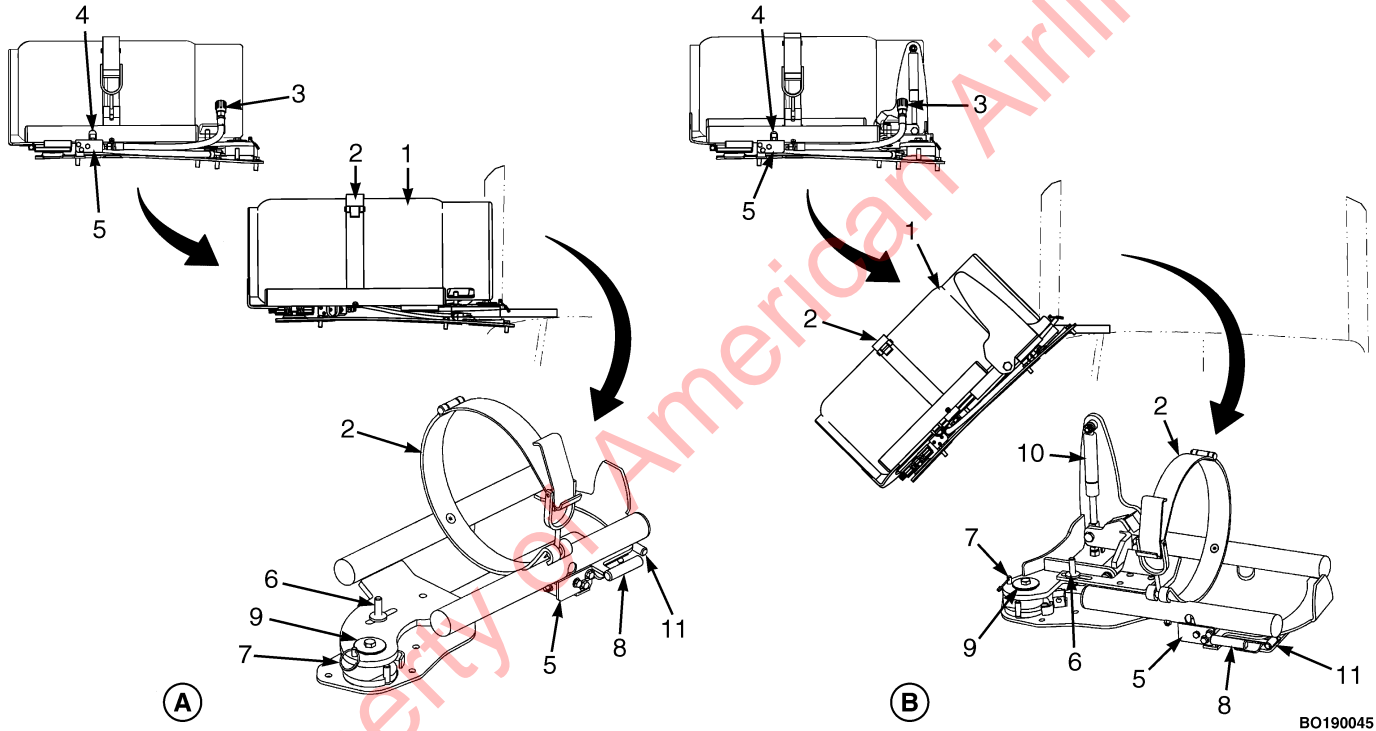

BO190045

Figure 51. LPG Tank and Bracket

Legend for Figure 51**A. SWING OUT BRACKET**

1. LPG TANK
2. TANK STRAP
3. QUICK DISCONNECT FITTING
4. HYDROSTATIC RELIEF VALVE
5. MANIFOLD BLOCK
6. ALIGNMENT PIN

B. EZXCHANGE TANK BRACKET

7. STOP PIN
8. BRACKET HANDLE
9. BRACKET PIVOT
10. GAS SPRING ()
11. BRACKET RELEASE PIN

LPG Tank, Fill**WARNING**

Read and follow all the refueling precautions and instructions under Liquefied Petroleum Gas (LPG). Removable LPG tanks must be removed from the fork lift before filling.

NOTE: The following instructions are general procedures. There is a variation in equipment for filling LPG tanks. The local authorities that have jurisdiction have specific rules and regulations for filling LPG tanks. Make sure these rules and regulations are available and understood.

1. Check the gauge on tank to make sure it needs filling. During the fill operation, the LPG tank must be in a position so that the liquid level indicator will always be in the vapor space above the liquid level.

2. Open the liquid outlet valve and bypass return valve on the storage tank.

3. Start the pump.

4. Connect the supply hose to the quick disconnect fitting on the LPG tank (see **Figure 51**). If the LPG tank has an auxiliary fill fitting, connect the supply hose to this fitting. Make sure the correct adapter is used to connect the supply hose to the auxiliary fill fitting.

5. Open the vent valve on the liquid level indicator.

6. Open the fuel valve on the LPG tank.

7. Open the valve on the end of the supply hose.

8. Watch for a discharge from the vent valve on the liquid level indicator. When a cloud of visible vapor appears, the LPG tank is full. Do not fill the LPG tank to more than the

maximum level indicated by the liquid level indicator. Immediately close the valve at the end of the supply hose.

9. Close the vent valve on the LPG tank.
10. Close the fuel valve on the LPG tank.
11. Disconnect the hose supply.
12. Stop the pump.
13. Close the liquid outlet and the bypass return valve on the storage tank.

LPG Tank, Install

NOTE: The LPG bracket must be in the swing out position to install the LPG tank. If your lift truck has the swing out and drop down bracket, position the bracket in the drop down position. See **Figure 51**.

WARNING

When closing the LPG tank strap, do not wrap your fingers around the strap handle. The strap can close quickly and with enough force to cause injury to the fingers and hand.

1. Place the LPG tank into the bracket. Be sure alignment pin on tank bracket is properly aligned with the hole in the

tank. If the pin is damaged, repair it before installing the tank. Secure the tank strap around the tank and close the strap.

2. Pull the stop pin and swing the LPG tank bracket into the resting position on the counterweight. Be sure that the bracket locks into position.
3. Connect the quick-disconnect fitting on the LPG tank. See **Figure 51**.
4. Turn the fuel valve counterclockwise to open the fuel valve.
5. Inspect the fuel system for leaks when the fuel valve is open. There are four methods used to inspect the fuel system for leaks:

a. Sound - Listen for sound of LPG escaping from a tank fitting or hose connection.

b. Smell - LPG has a very distinctive odor. If you smell LPG, **DO NOT** start the engine.

c. Soapy Water - This method is used in conjunction with **Step b** above. If the odor of LPG is present but escaping fuel cannot be heard, apply soapy water to the fittings and observe for bubbles.

d. Frost - If the amount of LPG escaping is sufficient, frost may appear on the fittings.

Gasoline or Diesel Fuel

WARNING

When fuel is added, keep the funnel or fuel nozzle in contact with the metal of the fuel tank to reduce the possibility of static electric sparks. Clean any spilled fuel.

1. Remove the fuel cap. Make sure the fuel tank is filled with the correct fuel for the type of engine in the lift truck. Clean the fuel cap and make sure vent is clear.

2. Replace the fuel cap.

Wheels and Tires

General

The S series lift trucks have solid rubber tires (often called cushion tires) that are pressed onto the rim. The H series lift trucks have pneumatic tires or solid rubber tires that look like pneumatic tires. These variations in tires also cause a

variation in the types of wheels and the disassembly and assembly procedures.

How to Change a Solid Rubber Tire (S Series)

WARNING

The type of solid rubber tire is shown on the Nameplate. Make sure the Nameplate is correct for the type of tires on the lift truck.

Wheels must be changed and tires repaired by trained personnel only.

Always wear safety glasses.

NOTE: Solid rubber tires made from softer or harder material can be installed as optional equipment. The tread on the solid rubber tires can be either smooth or it can have lugs. Do not mix types of tires or tread on lift truck.

1. Raise the lift truck as described in **How to Put a Lift Truck on Blocks** in this manual.

2. Remove the wheel nuts and remove the wheel from the lift truck. Lift truck wheels are heavy.

Remove and Install the Tire on the Wheel

NOTE: Make sure the tires are installed on the wheels so that the outside edges of the tire and wheel are as shown in **Figure 52**. Also check the Nameplate of the lift truck for the correct tire size and tread width.

1. The correct tools, equipment and a press ring must be used for each size of wheel. Use a press to push the wheel from the rim and tire. The capacity of the press must be approximately 355 to 1779 kN (80,000 to 400,000 lb). For the tire sizes, see the Nameplate.
2. When the drive wheels are installed on the lift truck, tighten the wheel nuts to 340 to 380 N•m (251 to 280 lbf ft).

3. The steering wheels are fastened to the spindle of the steering axle with a large castle nut. Make sure inner and outer bearings are correctly lubricated with grease. Install inner bearing assembly and wheel on spindle. Install outer bearing cone and castle nut. Tighten castle nut up to 68 N•m (50 lbf ft) while wheel is rotated. Loosen castle nut until hub turns freely with no end play. Tighten castle nut to 3 N•m (27 lbf in). Install cotter pin in castle nut. If the cotter pin cannot be installed, loosen the castle nut to the first position where the cotter pin can be installed. Install caps for bearings.

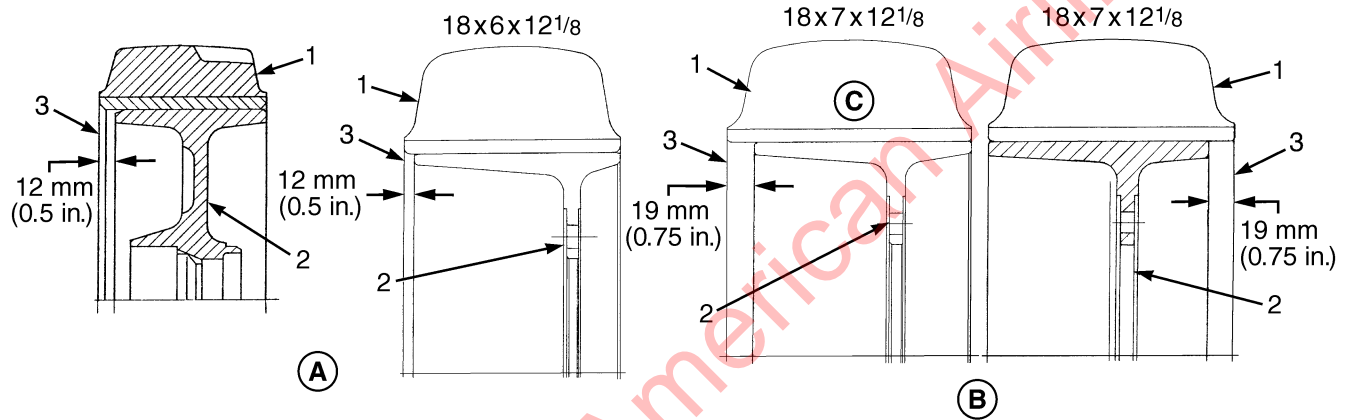

BO190168

- | | | |
|---------------------------------|---------------------------|---------------|
| A. STEERING TIRE AND WHEEL | B. DRIVE TIRES AND WHEELS | C. WIDE TREAD |
| 1. OUTSIDE OF SOLID RUBBER TIRE | 2. WHEEL | 3. OVERHANG |

Figure 52. Tires and Wheels S40-70 and S55FTS Lift Trucks

Pneumatic Tire With Tube, Repair

Remove Wheels From Lift Truck

WARNING

A solid rubber tire that is the same shape as a pneumatic tire can be installed on a three-piece or four-piece wheel for a pneumatic tire. **DO NOT** make changes in the parts of the rim if this type of solid rubber tire is installed instead of a pneumatic tire. Changes to the parts of the rim can cause a failure of the wheel and cause an accident.

The type of tire and the tire pressure (pneumatic tires) are shown on the Nameplate. Make sure the Nameplate is correct for the type of tires on the lift truck.

WARNING

Wheels must be changed and tires repaired by trained personnel only.

Deflate tire completely before removing the wheel from the lift truck. If dual wheels are used, deflate both tires. Air pressure in the tires can cause the tire and rim parts to explode causing serious injury or death.

Always wear safety glasses.

Never loosen the nuts that hold the inner and outer wheel halves together when there is air pressure in the tire.

1. Put the lift truck on blocks as described in **How to Put a Lift Truck on Blocks** at the beginning of this section.
2. Remove the air from the tire. Remove the valve core to make sure that all of the air is out of the inner tube. Push a wire through the valve stem to make sure that the valve stem does not have a restriction.
3. Remove the wheel nuts and remove the wheel and tire from the lift truck. Lift truck tires and wheels are heavy.

Remove Tire From Wheel

When disassembling wheels, see **Figure 53**. There are several types of wheels used on this series of lift trucks. See **Tire Removal, Two-Piece Wheel** and **Tire Removal, Three- and Four-Piece Wheels**.

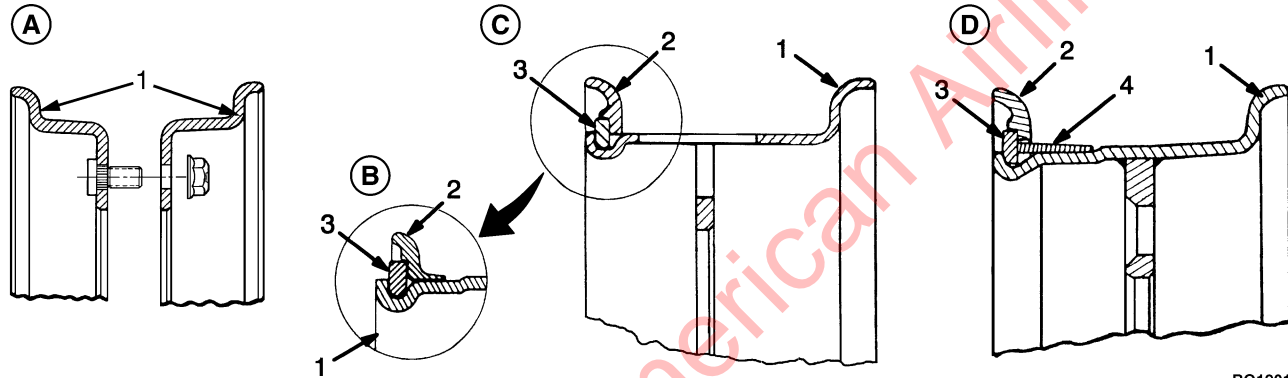

BO190184

NOTE: TUBELESS TIRES ARE MOUNTED ON WHEEL TYPES SHOWN IN ILLUSTRATIONS B OR D.

- A.** TWO-PIECE WHEEL
- B.** OPTIONAL RIM ASSEMBLY

- C.** THREE-PIECE WHEEL
- D.** FOUR-PIECE WHEEL

- 1. WHEEL RIM
- 2. SIDE FLANGE

- 3. LOCK RING
- 4. FLANGE SEAT

Figure 53. Types of Pneumatic Wheels

Tire Removal, Two-Piece Wheel

WARNING

Make sure all of the air pressure is removed from the tire before a wheel is disassembled. Air pressure in the tires can cause the tire and rim parts to explode causing serious injury or death.

Keep tire tools in firm contact with the wheel parts. If the tool slips, it can move with enough force to cause an injury.

1. Remove the nuts that fasten the wheel rims together.

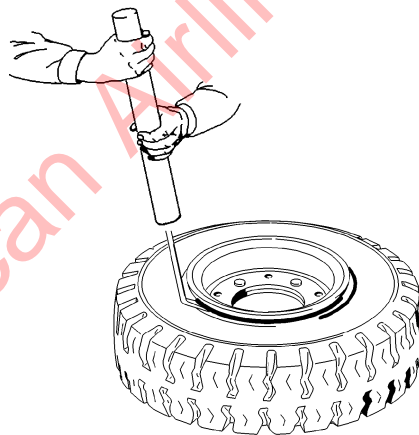
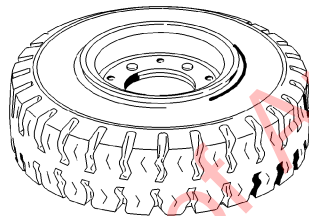

2. Loosen the tire bead from the wheel rim.

3. Remove the wheel rims from tire. Remove the inner tube and flap.

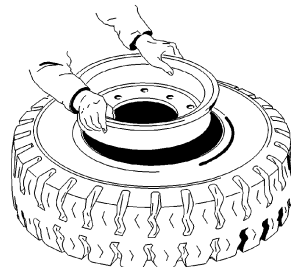

Maintenance

HYSTER

Tire Removal, Three- and Four-Piece Wheels

⚠ WARNING

Make sure all of the air pressure is removed from the tire before a wheel is disassembled. Air pressure in the tires can cause the tire and rim parts to explode causing serious injury or death.

Keep tire tools in firm contact with the wheel parts. If the tool slips, it can move with enough force to cause an injury.

1. Loosen the tire bead from the side flange.

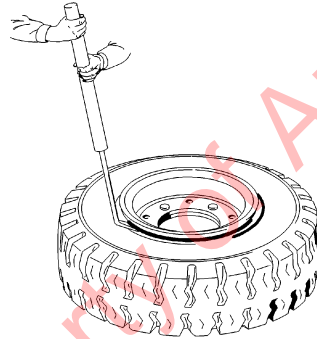

2. Put the tire tool into the slot between the lock ring and wheel rim. Remove the lock ring and side flange. If there is a flange seat, remove it.

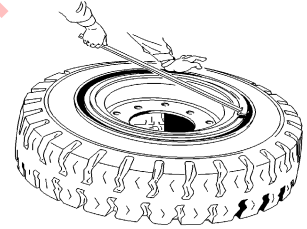

3. Loosen the bead from the other side of the wheel rim. Remove the valve stem from the wheel.

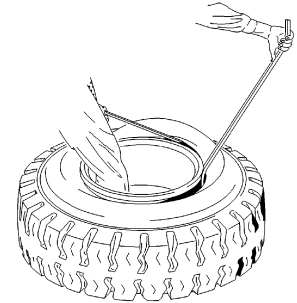

4. Remove the wheel rim from the tire.

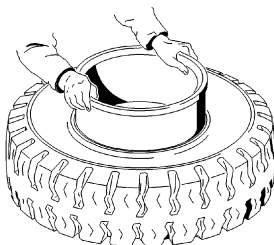

Install Wheel in Tire

WARNING

Damage to the tire and wheel assembly and injury or death can occur if you do not do the following procedures:

- Clean and inspect all parts of the wheel before installing the tire.
- DO NOT use any damaged or repaired wheel parts.
- Make sure that all parts of the wheel are the correct parts for that wheel assembly.
- DO NOT mix parts between different types or manufacturers of wheels.

- DO NOT mix types of tires, type of tire tread, or wheel assemblies of different manufacturers on any one lift truck.

Do not use a steel hammer on the wheel. Use a rubber, lead, plastic, or brass hammer to put parts together. Make sure that the side ring is in the correct position. The ends of the side ring must not touch. The clearance at the ends of the side ring will be approximately 13 to 25 mm (0.5 to 1.0 in.) after it is installed. If the clearance is wrong, the wrong part has been used.

1. Clean and inspect all parts of the wheel. Paint any parts that have rust or corrosion.
2. Install a new inner tube in the tire. Used tubes and flaps can cause tire failure.

WARNING

Do not lubricate the tire bead with antifreeze or petroleum-based liquid. Vapors from these liquids can cause an explosion during inflation or use.

3. Apply a rubber lubricant or a soap solution to the tire bead and tube.
4. Install a new tire flap.

WARNING

Do not lubricate the tire bead with antifreeze or petroleum-based liquid. Vapors from these liquids can cause an explosion during inflation or use.

5. Make sure the rim is the correct size for the tire. Lubricate the part of the wheel that contacts the bead and flap.

6. Install the three-piece or four-piece wheel in the tire as shown in **Tire Installation, Three- or Four-Piece Wheel**.

7. Install the two-piece wheel in the tire as shown in **Tire Installation, Two-Piece Wheel**.

Tire Installation, Three- or Four-Piece Wheel

WARNING

Damage to the tire and wheel assembly and injury or death can occur if you do not do the following procedures:

- Clean and inspect all parts of the wheel before installing the tire.
- DO NOT use any damaged or repaired wheel parts.
- Make sure that all parts of the wheel are the correct parts for the wheel assembly.

- DO NOT mix parts between different types or manufacturers of wheels.
- DO NOT mix types of tires, type of tire tread, or wheel assemblies of different manufacturers on any one lift truck.

Do not use a steel hammer on the wheel. Use a rubber, lead, plastic, or brass hammer to put parts together. Make sure that the side ring is in the correct position. The ends of the side ring must not touch. The clearance at the ends of the side rings will be approximately 13 to 25 mm (0.5 to 1.0 in.) after it is installed. If the clearance is wrong, the wrong part has been used.

1. Install the inner tube and the rubber flap in the tire.



2. Install the wheel rim in the tire. Make sure the stem of the inner tube is aligned with the slot in the rim.

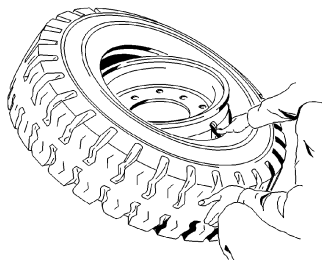

3. Turn over the rim and tire. Put blocks under the rim so that the rim is 8 to 10 cm (3 to 4 in.) above the floor. Install the flange seat (if used) and the lock ring.

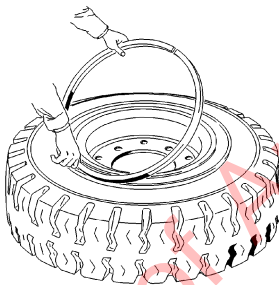

4. Put the lock ring in the correct position on the rim. Add air pressure to the tire as described in **Add Air to Pneumatic Tires With Tube.**

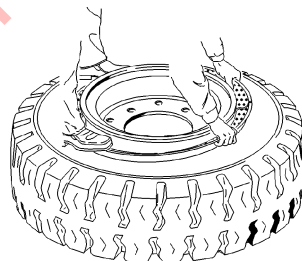

Tire Installation, Two-Piece Wheel



CAUTION

Do not use pneumatic-shaped, solid tires on two-piece bolt together drive wheels. Spinning may occur.

1. Install the inner tube and the rubber flap in the tire. Install both halves of the wheel rim in the tire. Make sure the stem of the inner tube is aligned with the slot in the rim.



Maintenance

HYSTER

2. Tighten the nuts that hold the rim halves together to 175 N•m (130 lbf ft). Add air pressure to the tire as described in **Add Air to Pneumatic Tires With Tube**.

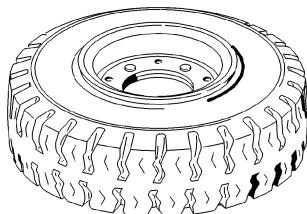

Add Air to Pneumatic Tires With Tube

WARNING

Add air pressure to the tires only in a safety cage. See Figure 54. Inspect the safety cage for damage before use. When air pressure is added, use a chuck that fastens onto the valve stem of the inner tube. Make sure there is enough hose to permit the operation to stand away from the safety cage when air pressure is added to the tire.

WARNING

Do not sit or stand by the safety cage. Do not use a hammer to try and correct the position of the side flange or lock ring when the tire has air pressure greater than 20 kPa (3 psi) of air pressure to the tire.

1. Put the tire in a safety cage. See Figure 54.
2. Add 20 kPa (3 psi) of air pressure to the tire.
3. Check that all wheel parts are correctly installed. Hit the lock ring lightly to make sure that it is in the seat.

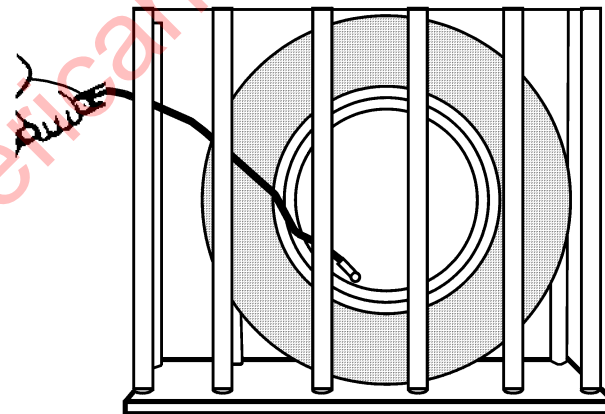

BO260046

Figure 54. Add Air to Tires With Tube

4. If installation is correct, add air pressure to the tire to the specified pressure. See Nameplate.

5. Check that all wheel parts are correctly installed. If installation is not correct, remove all of the air pressure from the tire. Remove the valve core to make sure all of the air pressure has been removed and then make adjustments. The clearance at the ends of the lock ring will be approximately 13 to 25 mm (0.5 to 1.0 in.) when the tire has the correct air pressure.

Install the Wheels

Install the wheel on the hub. Tighten the nuts in a cross pattern and torque to 450 to 500 N•m (332 to 369 lbf ft) for the drive wheel nuts and 155 to 175 N•m (114 to 129 lbf ft) for steer wheel nuts. If the wheels are the two-piece rims, make sure the nuts that fasten the rim halves together are toward the hub when they are installed.

Pneumatic Tubeless Tire, Repair

Remove Tire From Lift Truck

WARNING

Wheels must be changed and tires repaired by trained personnel only.

Deflate tire completely before removing the wheel from the lift truck. If dual wheels are used, deflate both tires. Air pressure in the tires can cause the tire and rim parts to explode causing serious injury or death.

Always wear safety glasses.

Never loosen the nuts that hold the inner and outer wheels halves together when there is air pressure in the tire.



WARNING

DO NOT mix brands of rubber sealing rings and tires. Serious injury to personnel or damage to the lift truck can occur if the rubber sealing rings are not compatible with the tire brand.

Specially designed rubber sealing rings enable tubeless tires to be used on wheel rims that were designed to be used with a tube. A rubber sealing ring is inserted inside the tire between the tire beads and ensures the air tightness of the existing wheel and the tubeless tire. This rubber sealing ring is referred to as either a Tubeless Bead Seal (TBS) or a Tubeless Sealing Ring (TSR). The TBS has a separate valve stem and can be removed separately from the rubber sealing ring. On a TSR tire, the valve stem is

Maintenance

HYSTER

integrated into the rubber sealing ring and cannot be removed separately from the rubber sealing ring. See **Figure 53**.

1. Put the lift truck on blocks as described in HOW TO PUT THE LIFT TRUCK ON BLOCKS at the beginning of this section.
2. Remove the valve cap and core to remove all air from the tire.
3. Remove the wheel nuts and remove the wheel and tire from the lift truck. Lift truck tires and wheels are heavy.

Remove Tire From Wheel

WARNING

Make sure all of the air pressure is removed from the tire before a wheel is disassembled. Air pressure in the tires can cause the tire and rim parts to explode causing serious injury or death.

Keep tire tools in firm contact with the wheel parts. If the tool slips, it can move with enough force to cause an injury.

NOTE: There are several types of wheels used on these lift trucks. When disassembling wheels, see **Figure 53**.

1. If the tire is equipped with a Tubeless Bead Seal (TBS) style rubber sealing ring with a separate valve stem, turn the valve stem 1/4 turn and remove valve stem from wheel, as shown in illustration. If the tire is equipped with a Tubeless Sealing Ring (TSR) style rubber sealing ring, the valve stem is an integral part of the rubber sealing ring and is not removable.

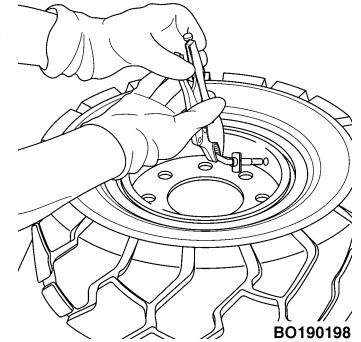

2. Put wheel and tire assembly on the press. Position the feet of the press on the loose flange. Push press down on loose flange to expose the locking ring.

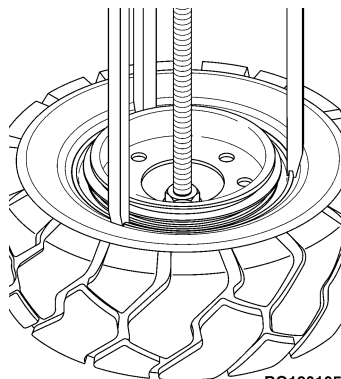

BO190185

3. Remove the loose flange locking ring and the advance band (four-piece wheel only) using a tire tool.

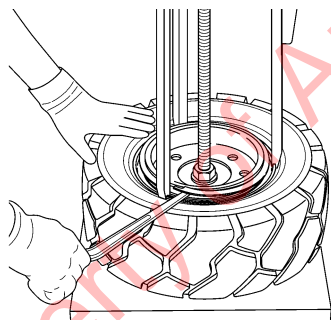

BO190186

4. Remove the press and remove the loose flange locking ring and the advance band (four-piece wheel only) from the tire and wheel assembly.

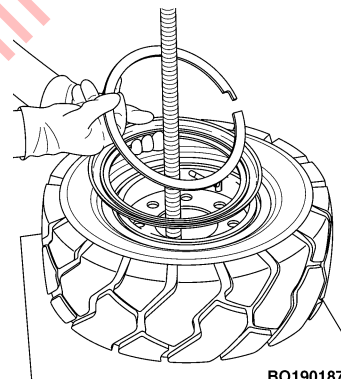

BO190187

5. Push the TBS or TSR toward the inside of the tire to remove it.

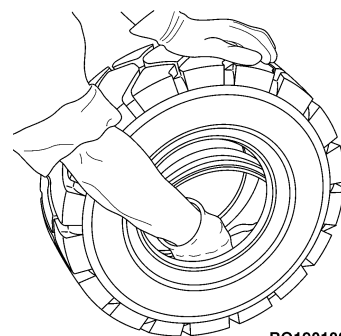

BO190188

Install Tire on Wheel

⚠ WARNING

Damage to the tire and wheel assembly and injury or death can occur if you do not do the following procedures:

- Clean and inspect all parts of the wheel before installing the tire.
- DO NOT use any damaged or repaired wheel parts.
- Make sure that all parts of the wheel are the correct parts for that wheel assembly.
- DO NOT mix parts between different types or manufacturers of wheels.
- DO NOT mix types of tires, type of tire tread, or wheel assemblies of different manufacturers on any one lift truck.

⚠ WARNING

Do not use a steel hammer on the wheel. Use a rubber, lead, plastic, or brass hammer to put parts together.

⚠ WARNING

Do not lubricate the tire bead with antifreeze or petroleum-based liquid. Vapors from these liquids can cause an explosion during inflation or use.

⚠ WARNING

DO NOT mix brands of rubber sealing rings and tires. Serious injury to personnel or damage to the lift truck can occur if the rubber sealing rings are not compatible with the tire brand.

1. Clean interior and exterior bead area of the tire. Lubricate tire beads and the inside of the tire, up to the tire shoulders. Apply lubricant to entire underside of the TBS or TSR. Use lubricant approved by the tire manufacturer.

NOTE: If the wheel rim width is less than six inches, the TBS will contain one valve hole to accommodate the needle valve. If the wheel rim width is greater than

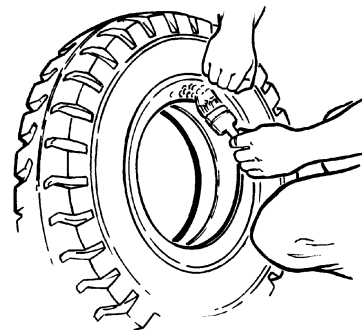

six inches, the TBS will have two holes for the needle valve.

One hole is centrally located and the other is offset, to ensure the correct positioning of the valve in the valve slot. The valve hole that is not used should be sealed with a small plastic plug.

2. For TBS, apply lubricant to the needle valve and the valve hole that will be used (see **NOTE** in Step 1), by inserting and removing the lubricated valve several times. If a three- or four-piece wheel is being used, remove the valve. If a two-piece wheel is being used, leave valve in valve hole.

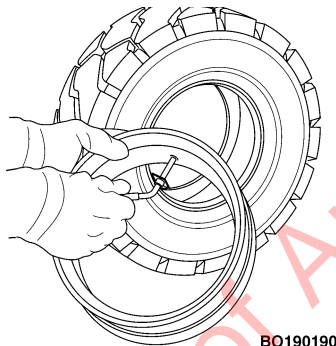

BO190190

If the TBS has two valve holes, lubricate the plastic plug and insert into valve hole that will not be used.

3. Place the TBS or TSR rubber sealing ring inside the tire, making sure the wings are not folded over. For the TBS rubber sealing ring, with separate valve stem, make a mark on the tire to note the position of the valve hole. For TSR rubber sealing ring with an integral valve stem, align valve slot in the rim with the TSR valve stem.

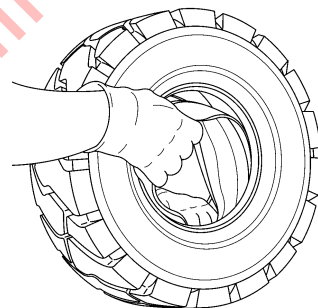

BO190191

4. Apply lubricant to the rim. If a four-piece wheel is being used, lubricate the advance band. Slide the tire and rubber sealing ring onto the wheel.

Maintenance

HYSTER

For TSR, use a lever to push the valve stem through the valve slot in the wheel. For TBS tires, line up the valve hole in the TBS with the valve slot in the wheel. Lubricate and insert the valve into the valve hole. Make sure it is fully inserted.

5. For TBS, with separate valve stems, place the wheel and tire assembly on a flat surface. Turn the valve a 1/4 turn to lock the collar under the edges of the rim valve slot.

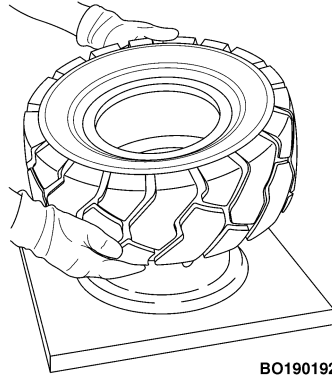

BO190192

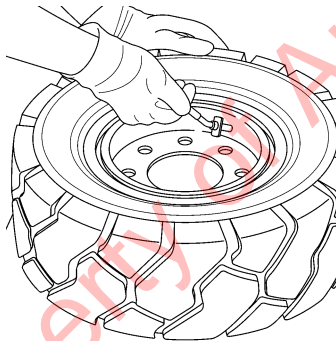

BO190193

6. Raise the tire and position the base and threaded stem of the press through the hole in the center of the wheel. Insert in wheel assembly, the following parts:

- Advance band (four-piece wheel only)
- Loose flange
- Locking ring

7. Position the advance band. Ensure that it does not go in too far and damage the valve. Position the arms of the press onto the loose flange.

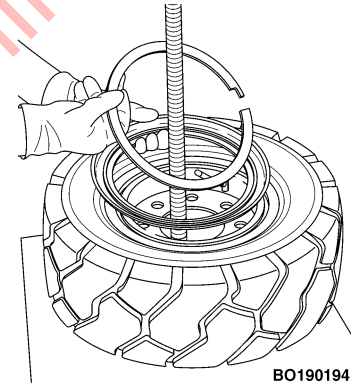

BO190194

⚠ CAUTION

DO NOT compress the bead too far and cause the rubber sealing ring to become distorted and damage the valve stem.

Push down on press to depress the tire beads until the locking ring groove is fully exposed.

8. Insert tire tool into the locking ring groove, and a vise grip on other end. Remove vise grip. Release the press and check that all component parts are correctly positioned. Replace the valve core.

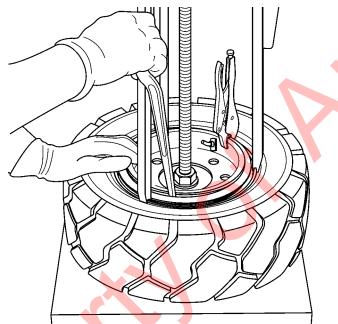
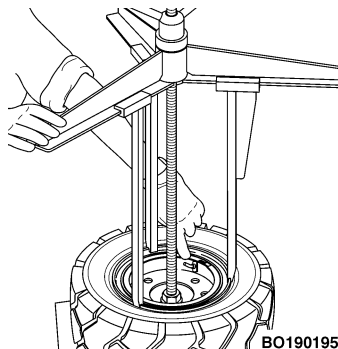

9. Inflate tire to 103 kPa (15 psi). Tap wheel with a mallet to ensure all components are correctly sealed. Remove the press from wheel and tire assembly.

Add Air to Pneumatic Tubeless Tire**⚠ WARNING**

Add air pressure to the tires only in a safety cage. See Figure 55. Inspect the safety cage for damage before use. When air pressure is added, use a chuck that fastens onto the valve stem. Make sure there is enough hose to permit the operator to stand away from the safety cage when air pressure is added to the tire. Do not sit or stand by the safety cage.

Add air to tire to the recommended pressure that is shown on the Nameplate. Install valve cap to ensure air stays in the tire.

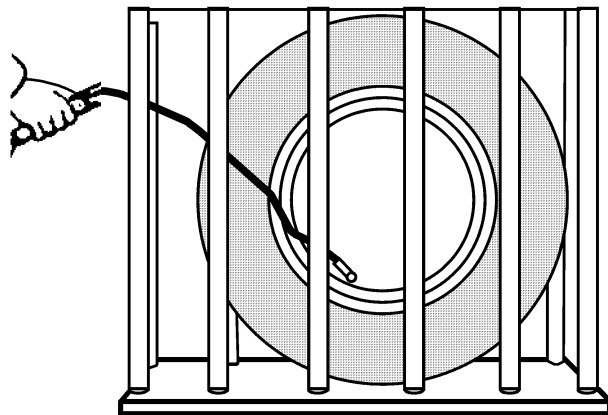

BO260046

Figure 55. Add Air to Tubeless Tire

Install the Wheels

Install the wheel on the hub. Tighten the nuts in a cross pattern and torque to 450 to 500 N•m (332 to 369 lbf ft) for drive wheel nuts and 155 to 175 N•m (114 to 129 lbf ft) for steer wheel nuts. If the wheels are the two-piece rims, make sure the nuts that fasten the rim halves together are toward the hub when they are installed.

Solid Rubber Tires on Pneumatic Wheels, Change

WARNING

Wheels must be changed and tires repaired by trained personnel only.

Always wear safety glasses.

1. Put the lift truck on blocks as described in **How to Put a Lift Truck on Blocks** at the beginning of this section.
2. Remove the wheel nuts and remove the wheel and tire from the lift truck. Lift truck tires and wheels are heavy.

Remove Tire From Wheel

WARNING

Keep tire tools in firm contact with the wheel. If the tool slips, it can move with enough force to cause serious injury.

NOTE: When disassembling wheels, see **Figure 53**. There are several types of wheels used on these series of lift trucks.

WARNING

Wheels must be changed and tires repaired by trained personnel only.

Always wear safety glasses.

1. Put the wheel rim on the bed of the press. Put the cage in position on the tire. Use the press to push the tire away from the side flange.

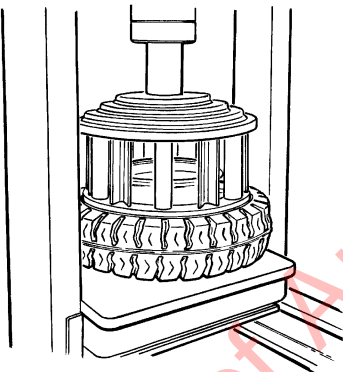

2. Put the tire tool into the slot between the lock ring and the wheel rim. Remove the lock ring and side flange.

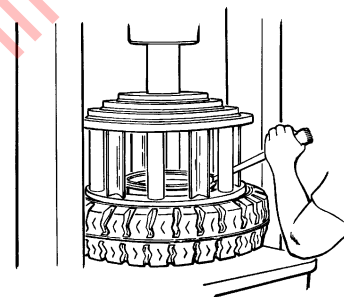

3. Turn the tire over. Put a support under the wheel rim. Make sure the wheel rim is at least 150 to 200 mm (6 to 8 in.) from the bed of the press.

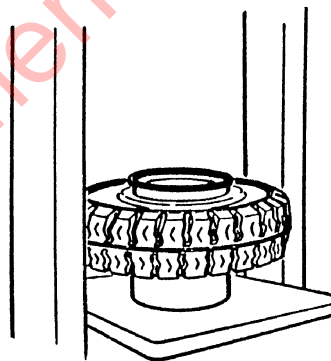

4. Put the cage in position on the tire. Use the press to push the tire from the wheel rim.

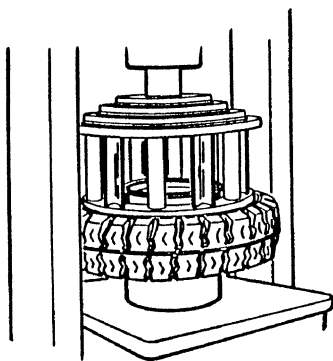

- DO NOT mix parts between different types or manufacturers of wheels.
- DO NOT mix type of tires, type of tire tread, or wheel assemblies of different manufacturers on any one lift truck.

Do not use a steel hammer on the wheel. Use a rubber, lead, plastic, or brass hammer to put parts together. Make sure that the lock ring is in the correct position. The ends of the lock ring must not touch. The clearance at the ends of the side ring will be approximately 13 to 25 mm (0.5 to 1.0 in.) after it is installed. If the clearance is wrong, the wrong part has been used.

NOTE: When disassembling wheels, see **Figure 53**. There are several types of wheels used on these series of lift trucks.

Install Tire on Wheel

WARNING

Damage to tire and wheel assembly and injury or death can occur if you do not do the following procedures:

- Clean and inspect all parts of the wheel before installing the tire.
- DO NOT use any damaged or repaired wheel parts.
- Make sure that all parts of the wheel are the correct parts for the wheel assembly.

CAUTION

Too much lubricant can cause the tire to slide and move around the wheel rim.

1. Lubricate the wheel rim and the inner surface of the tire with tire lubricant or soap.

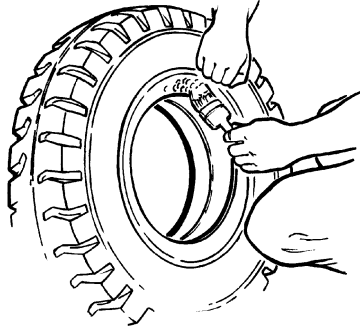

2. Put the wheel rim on the bed of the press. Put the tire over the wheel rim. Put the cage in position on the tire. Use the press to install the tire on the wheel rim.

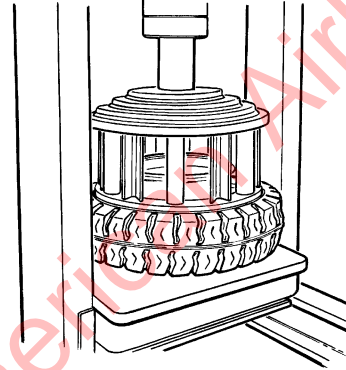
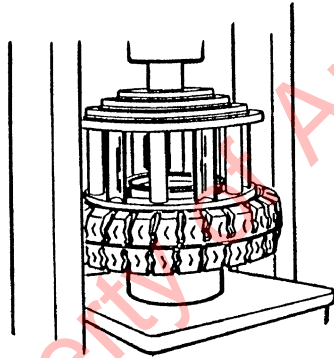

3. Remove the cage and put the flange seat (if used), the side ring, and the lock ring in position on the wheel rim. Install the cage on the tire. Use the press to push the tire onto the wheel rim so that the side flange and lock ring can be installed.

4. While the cage is holding the tire on the wheel rim, install the lock ring. Use a tire tool to make sure the lock ring is in the correct position.

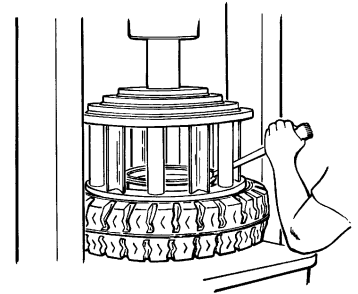

Dual Drive Wheels, Install

NOTE: Some lift trucks can have dual drive wheels. The following procedures describe the steps to install the dual sets of wheels.

1. See **Figure 56**. Install the inner wheel on the hub. Tighten the nuts to a torque of 450 to 500 N•m (332 to 369 lbf ft) for the drive wheel nuts and 155 to 175 N•m (114 to 129 lbf ft) for steer wheel nuts. If two-piece wheels are installed, make sure the nuts that fasten the rim halves together are toward the brake drum when they are installed.

2. Install the spacer to the axle shaft. Tighten the nuts to 98 N•m (72 lbf ft).

3. Install the outer wheel on the spacer. Tighten the nuts to a torque of 450 to 500 N•m (332 to 369 lbf ft) for the drive wheel nuts and 155 to 175 N•m (114 to 129 lbf ft) for steer wheel nuts. If the wheels are the two-piece rims, make sure the nuts that fasten the rim halves together are toward the brake drum when they are installed.

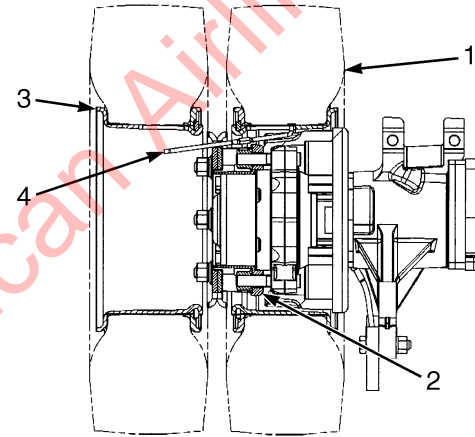

HO260016

1. INNER WHEEL
2. ADAPTER ASSEMBLY
3. OUTER WHEEL
4. EXTENSION, AIR VALVE

Figure 56. Dual Drive Wheels Installation

Jump-Starting the Lift Truck

Jump-Starting Using a Battery Charger

CAUTION

DO NOT try to start the engine by pushing or towing the lift truck. Damage to the transmission can occur if engine is started by pushing or towing lift truck.

If the battery becomes discharged and requires a booster battery to start the engine, follow these procedures carefully when connecting the jumper cables:

1. Disconnect the negative battery terminal of the lift truck being started.
2. Always connect positive jumper cable to positive terminal of discharged battery and negative jumper cable to negative terminal.
3. Always connect jumper cable, that is the ground cables, last.
4. Always connect jumper cables to discharged battery before connecting them to booster battery.

Jump-Starting Using Another Lift Truck

WARNING

To prevent possible arcing between the two lift trucks, make sure that the lift trucks are not touching.

CAUTION

DO NOT try to start the engine by pushing or towing the lift truck. Damage to the transmission can occur if engine is started by pushing or towing lift truck.

1. Always connect positive jumper cable to positive terminal of discharged battery and negative jumper cable to negative terminal.
2. Always connect jumper cable, that is the ground cable, last.
3. Always connect jumper cables to discharge lift truck battery before connecting them to the fully charged lift truck battery.

Jump-Starting the Lift Truck

Jump-Starting Using a Battery Charger

CAUTION

DO NOT try to start the engine by pushing or towing the lift truck. Damage to the transmission can occur if engine is started by pushing or towing lift truck.

If the battery becomes discharged and requires a booster battery to start the engine, follow these procedures carefully when connecting the jumper cables:

1. Disconnect the negative battery terminal of the lift truck being started.
2. Always connect positive jumper cable to positive terminal of discharged battery and negative jumper cable to negative terminal.
3. Always connect jumper cable, that is the ground cables, last.
4. Always connect jumper cables to discharged battery before connecting them to booster battery.

Jump-Starting Using Another Lift Truck

WARNING

To prevent possible arcing between the two lift trucks, make sure that the lift trucks are not touching.

CAUTION

DO NOT try to start the engine by pushing or towing the lift truck. Damage to the transmission can occur if engine is started by pushing or towing lift truck.

1. Always connect positive jumper cable to positive terminal of discharged battery and negative jumper cable to negative terminal.
2. Always connect jumper cable, that is the ground cable, last.
3. Always connect jumper cables to discharge lift truck battery before connecting them to the fully charged lift truck battery.

Operating Procedures for a New or Rebuilt Engine

A new or rebuilt engine must be operated under special conditions during the first 50 hours. These special conditions prevent damage to the engine until the new parts can wear and adjust to fit each other.

1. Make sure the fluid levels of oil and coolant are correct.
2. Start and run the engine at approximately one-half throttle for 30 minutes for the first operation. Check the gauges and indicators for the correct operation during this first operating period. Check for leaks.
3. If the work conditions are slow and the loads are less than 50% of the truck capacity, a simulated work condition must be used during the first four hours of operation. Operate the lift truck with a minimum load of 75% capacity. Operate the engine through cycles from idle to full throttle and back to idle. Avoid long periods of high engine speeds with a light load during the first 50 hours of operation. High engine speeds with a light load can cause damage to the cylinders in the engine.

Changes to the Overhead Guard

WARNING

Do not operate the lift truck without the overhead guard correctly fastened to the lift truck.

Do not make changes to the overhead guard by welding. Changes that are made by welding, or by drilling holes that are too big in the wrong location, can reduce the strength of the overhead guard.

See your dealer for Hyster lift trucks BEFORE performing any changes to the overhead guard.

How to Put Internal Combustion Engine (ICE) Trucks in Storage

It is important to store your lift truck properly to protect it. The main areas of concern are engines, hydraulic components, and truck batteries. The length of storage time and the storage location determines what procedures you should follow.

Before placing any lift truck in storage, you must choose an area that is clean, dry, and free from airborne contaminants. For safety and increased usable floor area, remove

the forks and tag them with the lift truck serial number. For best protection, operate your internal combustion engine lift truck for a short period each month.

The following storage procedures are for conditions and temperatures above 0 °C (32 °F). Adjust these procedures for local conditions and any changes in conditions during storage. The preparations necessary for storage are also determined from the following conditions:

- Short-term storage is from one to six months. Long-term storage is over six months.
- Storage Location. A lift truck stored indoors will not require as much external protection as a lift truck stored outdoors.

Short-Term Storage

Perform the following steps to prepare your lift truck for storage from one to six months:

1. Check lubricant and fluid levels. Completely fill the fuel tank. Make sure the coolant mixture will protect cooling system and engine to lowest temperature expected during storage. Make sure all caps and dipsticks are installed correctly.

2. Fully lower the mast. If lift truck is equipped with forks, tilt mast **FORWARD** until the tips of the forks touch the floor. Apply a thin coat of fresh, high grade SAE 30 or 40 weight engine oil to the exposed cylinder rods. If the forks are removed, tilt mast **BACKWARD** until cylinders are completely retracted. This protects the cylinder rods.

3. Check that all switches and accessories are in the **OFF** position.

4. Activate each control lever to relieve hydraulic pressure.

5. Install blocks, front and rear, at the drive wheels. If the lift truck must be left on an incline, put blocks on the downhill side of all wheels so that the lift truck cannot move. **DO NOT USE THE PARKING BRAKE.**

6. Disconnect the battery cables from the battery. Apply a protective coating to the cable connectors and battery terminals to prevent corrosion.

7. Check the tire pressure, if applicable. Make sure the tires have the correct pressure (see the Nameplate.)

8. Clean the lift truck and engine compartment to prevent corrosion.

9. If the lift truck is not stored indoors, put a cover over the lift truck to prevent damage from the weather. In wet conditions, a cover will not prevent corrosion to the lift truck.

Long-Term Storage

Do the following steps to prepare the lift truck for storage for 6 months or longer:

1. Complete all short-term storage procedures.
2. Wrap or cover all exterior lights, radiator grill, and air vents with a moisture barrier cover. Use tape to hold the covers in place.
3. Remove the battery or batteries from the lift truck. Store the battery or batteries in an approved space. Be sure to follow local regulations. Batteries that are stored for long periods can become damaged. Either keep batteries in service or follow the battery storage procedures below.
4. Spray exterior surfaces and frame with preservative coating.

While the Lift Truck is in Storage

Each month make a visual inspection for leaks or signs of deterioration. Take corrective action immediately. Check

the fluid level in engine, radiator, hydraulic tank, and brake master cylinder.

NOTE: Do not shut down an engine before it reaches operating temperature.

Each month set the park brake, start engine, and run until normal operating temperature is reached. This will coat the internal engine components with a film of oil and rid the engine of built-up condensation.

Each month all hydraulic cylinders must be cycled several times to keep the seals active and to coat the interior walls with oil. Actuate each cylinder, in both directions, until it reaches the stops.

Return lift truck to its storage state for another month.

How to Put Batteries in Storage

Batteries are to be placed on a wooden pallet and stored in a dry, moderately cool area.

Lead acid batteries will slowly "self-discharge" over a period of time due to their chemical makeup. If the self-discharge is left uncontrolled, excessive sulphation can occur which is difficult to reduce and can damage the anodes. A discharged battery with a specific gravity of 1.000 will

freeze at $-7.8\text{ }^{\circ}\text{C}$ ($18\text{ }^{\circ}\text{F}$) A fully-charged battery with a specific gravity of 1.280 will freeze at $-66\text{ }^{\circ}\text{C}$ ($-87\text{ }^{\circ}\text{F}$).

This "self-discharge" is due to a chemical reaction; therefore, that chemical reaction can be accelerated by heat resulting in more rapid "self-discharge." The rate of discharge can amount to an average of about 0.001 point drop in specific gravity per day.

The following procedure can be followed when placing a battery in storage or when not in operation for more than 30 days.

1. Give an equalizing charge prior to placing new batteries in storage. Used batteries are to be fully charged, then allowed to balance for approximately three more hours.
2. Neutralize and clean the battery. Clean with a solution of 100 grams (3.5 oz) of sodium bicarbonate (baking soda) per 1 liter (0.25 gal) of water.
3. Store in a cool, dry location.
4. Check each cell in the battery at least once every 30 days and boost charge when specific gravity falls below 1.240 Hg.
5. Protect batteries from ambient contamination.

If a greasy film forms on the top of a battery, this is acid and must be neutralized with the solution described above.

Putting a Stored Lift Truck Back Into Service

1. Remove all tape, covers, and preservation materials.
2. Check the lift truck for damage and missing components. Repair damage and/or replace missing components.

NOTE: If the lift truck has been stored longer than one year, all lubricants and fluids must be drained and replaced. See the **Periodic Maintenance** section of your service manual for the procedures.

3. Clean the battery cables and terminals. Check the battery voltage. If the voltage is not correct, charge battery. Connect battery cables to battery.
4. When a lift truck is to be put into service after storage, it must be given the 250-hour inspection shown in the **Recommended Schedule of Maintenance**.

How to Move a Lift Truck on a Transport

⚠️ WARNING

Stay a safe distance from the edge of docks, ramps, platforms, and other similar working surfaces. Watch the “tail swing.” Remember when traveling in the forward direction and the steering wheel is turned to move the lift truck away from the edge of the dock, the rear will swing toward the edge. This can cause the lift truck to fall off the dock.

⚠️ WARNING

IF THE LIFT TRUCK FALLS OFF THE DOCK, DO NOT JUMP OFF! HOLD FIRMLY TO STEERING WHEEL,

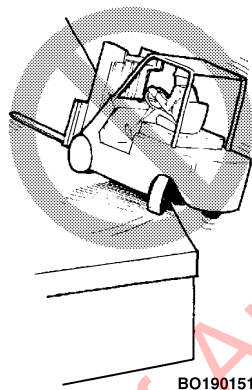

BRACE YOUR FEET, AND LEAN FORWARD AND AWAY FROM THE POINT OF IMPACT.

Before the lift truck is moved on a transport, check the selected route to make sure there is enough clearance for the lift truck as loaded on the transport vehicle. Bridges, overpasses, powerlines, and natural barriers can prevent clearance. Removal of the mast can be necessary.

If a trailer is the method of transportation, use blocks in front and back of the trailer tires to prevent movement of the trailer when the lift truck is loaded and unloaded. If a loading ramp is used, make sure that the ramp is the correct design and capacity.

If the lift truck is equipped with lifting eyes, use a crane to load and unload the lift truck from the transport. If the truck is not equipped with approved lifting eyes, do not lift the truck by attaching a lifting device to any other part of the lift truck for the purposes of loading or unloading.

Loading

WARNING

The straps or chains used to fasten the lift truck to the transport must be directly connected to the lift truck frame or to a component (drive axle, tow pin) that is solidly attached to the frame. Do not fasten a strap or chain to the mast or any attachment to hold the lift truck on the transport.

CAUTION

Make sure that any straps or chains used to fasten the lift truck to the transport do not contact any tubes, hoses, hydraulic cylinders, or other parts of the truck that are easily damaged.

If components and attachments must be removed for transport of the lift truck, see the **Service Manual** for removal procedures.

The operator must never leave a lift truck in a condition so that it can cause damage and injury. When the lift truck is loaded on the transport, do the following operations:

1. Apply the parking brake.

2. If the mast is mounted on the lift truck, fully lower the forks or carriage. Tilt the mast **FORWARD** until the tips of the forks touch the surface.

3. Put the direction control lever for the powershift transmission in **NEUTRAL** (N). If the lift truck has a manual transmission, leave the gears of the transmission engaged. DO NOT leave a manual transmission in **NEUTRAL** (N).

4. Turn the key switch to **OFF** to stop the engine, if truck is equipped with a key switch, or press the Power **ON/OFF** button, if truck is equipped with a keyless option. Check that all switches and accessories are turned **OFF**.

5. Put blocks in front and back of the lift truck tires to prevent any movement of the lift truck. Make sure the blocks are attached to the load surface.

If the lift truck is equipped with an LPG fuel system and is not in active use, close the fuel valve at the tank. If the lift truck is going to be left overnight or longer, the truck must be parked outside or the LPG tank must be removed and stored outside.

If the lift truck is transported in severe weather or any other condition that can damage the lift truck, cover the lift truck.

Make sure the protective cover is designed for the application and is securely fastened.

Unloading

If components normally attached to the lift truck were removed for transport, see the **Service Manual** for installation procedures.

1. If used, remove any protective cover.
2. Make sure the parking brake is applied.
3. Disconnect the straps or chains.
4. Remove the wheel blocks.
5. Check that all switches and accessories are turned **OFF**.
6. Unload the lift truck.

Preparation for Use

After being transported or stored, the lift truck must be prepared for use for proper operation. All problems must be corrected before use of the lift truck, see the **Service Manual** for procedures.

Preparation After Transport

1. Complete the unloading procedures.
2. Inspect the lift truck for damage and missing components.
3. Follow the steps in the section **How to Make Checks With the Engine Stopped**.

NO MATTER HOW YOU SAY IT ...

La Sécurité Ça Se Paye
La Seguridad Compensa
Betriebssicherheit Macht Sich Bezahlt
Passaa Oll Huoellinen
Veiligheid Voor Alles
Säkerhet Först
Essere Sicuro Paga
Seguranca Paga
Sikkerhet Først
Pinter Be Awas

सावधान और जिन्दा रहो !

في التأني السلامة

安全第一

WARNING

California Proposition 65 - This product contains and/or emits chemicals known to the State of California to cause cancer, birth defects, or other reproductive harm.

**SAFETY
PAYS!**

OPERATING MANUAL

FORTIS®

S40FT, S50FT, S55FTS, S60FT, S70FT (F187)
H40FT, H50FT, H60FT, H70FT (L177)

Property of American Airlines

DO NOT REMOVE THIS MANUAL FROM THIS UNIT