

HELI

The Specification

CBD15/18/20J-Li2 Series Walkie Electric Pallet truck

Warning PLEASE READ THIS MANUAL BEFORE USING!

Warning PLEASE DON'T USE IT BEFORE COMPLETING THE INSTALLATION!

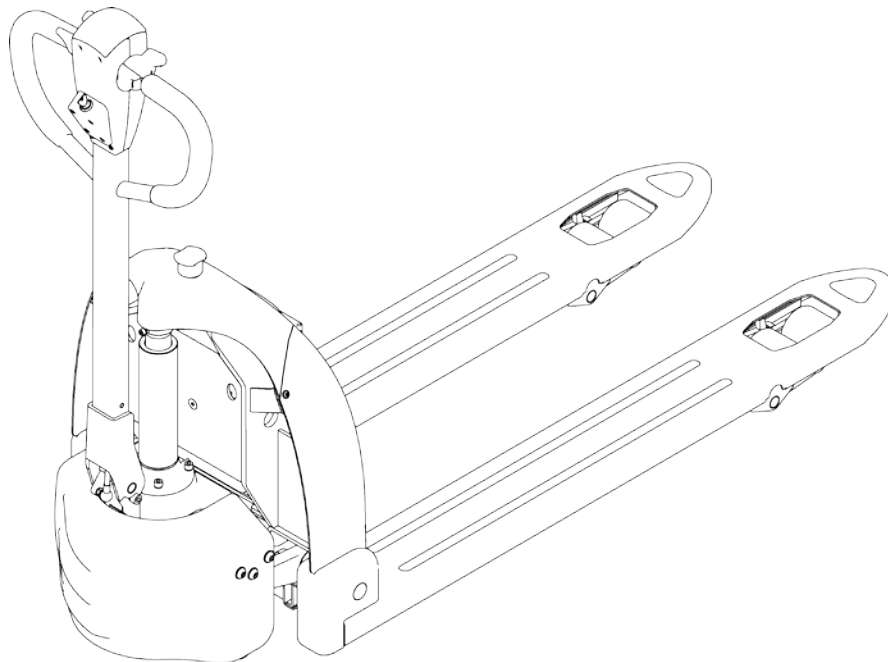

Introduction

In order to meet the needs of the national environmental protection request, To reduce industrial pollution and improve productivity, we develop new series of CBD15/18/20J-Li2 walkie Electric Pallet truck on the basis of absorption of the advantages of domestic & overseas battery Pallet truck, they are especially suitable for cargo loading and unloading, handling, stacking, etc for food, bank, light textile, station, port, logistics and other enterprises.

This manual describes the technical parameters of the Pallet truck, working principle and operation, maintenance, and other aspects. It can help operators use the Pallet truck more reasonable, make its maximum effect.

It is hoped that Operator strictly abide the regulations and the precautions in this manual when using the Pallet truck. Carefully use them so that your Pallet truck can be in the best working condition for long period of time to maximize it's effectiveness. And create better economic benefits.

The Statement

Our company production model CBD-J tpye 1.5T/1.8T/2.0T Walkie Electric Pallet Truck is a special motor vehicle used in factory ,tourist attractions ,amusement places which is specified by “special equipment safety supervision regulations” .

Catalogue

1.The General Introduction	5
2.Proper usage	6
Modification	6
3.Introduction of the product.....	7
3.1Model overview	7
4.Operating principle	9
Operating mechanism diagram:	9
5.Operating principle	10
5.1Running system	10
5.2Steering system	10
5.3 Brake structure and brake schematic diagram.....	10
5.4 Operating System	11
5.5 Electric System	11
5.6 Hydraulic principle	12
6. Electrical schematic diagram	13
6.1Electrical schematic diagram	13
7. Hydraulic Scheme	14
7.1Hydraulic Scheme	14
8.Operating Instruction	15
8.1 Operation	15
8.2Emergency reverse function	17
8.3 The use of the horn and the reversing horn	17
8.4 Battery capacity display	17
8.5 operation.....	17
9.Safety operation and matters needing attention	19
9.1 Repair and Maintenance	19
9.2 Routine Maintenance	20
9.3 Professional Maintenance Manual.....	20
9.4 battery maintenance, charging and maintenance.	22
10.Safety Caution.....	25
10.1 General rule	25
10.2 Storage and transportation	25
10.3 Check before using.....	26
10.4Safety operation regulation	26
11.Service Manual.....	30
11.1 Troubleshooting.....	30
11.2 Preparation before repair	31
11.3Check the amount of hydraulic oil.....	31
11.4 Complete repair,the preparation before using.....	31

1.The General Introduction

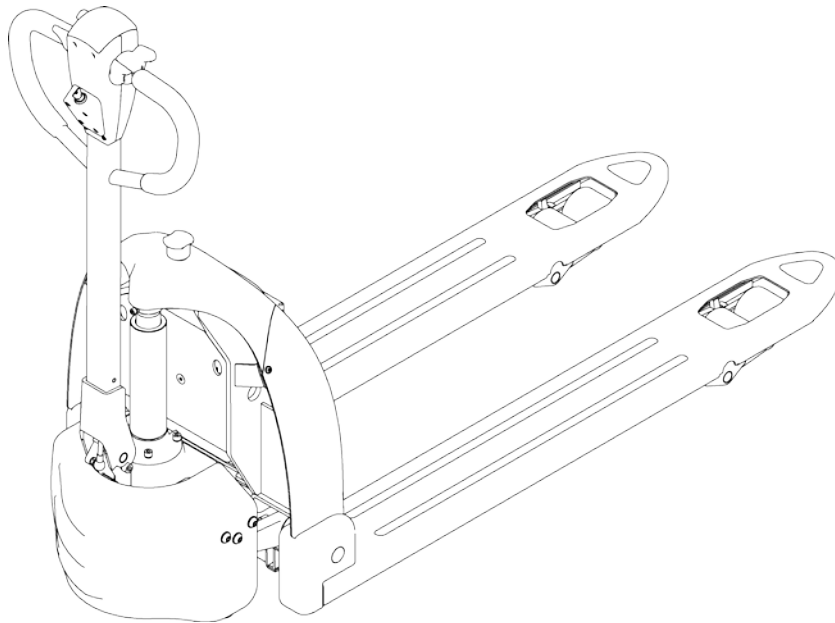

CBD15/18/20J-Li2 is a tramp type electric pallet truck. It adopts the advanced structure such as ring rod lifting system and new ac controller, at same time it is equipped with high quality motor, lithium battery and pump station motor. It has the characteristics of superior performance, convenient operation, flexible steering, reliable braking, good dynamic performance, less noise, less pollution and beautiful appearance.

This series truck is suitable for working on the smooth ground in warehouse, if not ,please don't use it.

The service environment:

- a. temperature not over +40°C, not under-10°C;
- b. the gradient can't over 3%;
- c. when environment temperature at +40°C,the relative humidity can't over 50% , At low temperature, allow big relative humidity;
- d. ground need hard and flat;
- e. It is forbidden to use this car in corrosive environment such as flammable and explosive or acid base.

2. Proper usage

Please use the electric pallet truck according to this specification.

This is a tramp type electric pallet truck with autonomous control, lifting and lowering is controlled by the handle button. Improper use can cause personal injury or machine damage. Operators or operating companies need to ensure proper use,

The Truck needs to be used on a firm, flat, intact surface and suitable surface, The truck is designed for indoor use at room temperature from -10°C to +40°C

Use under light load without using permanent barriers or pits, It is forbidden to operate on the slopes. During Operation, The goods must be placed approximately at the center of the truck's load center

Lifting or Carrying people is strictly prohibited, If carried goods. The goods must fall on the lifting point.

It is prohibited to use this truck on lifting or loading ramps.

The rated capacity is marked on the capacity label or nameplate. And the operator must pay attention to the warning signs and safety instructions.

Operating lighting must be at least 50LUX

Modification

Any modification that may affect the truck rated capacity, stability, or safety operations must be approved in advance by the Truck's original manufacturer or its authorized Manufacturer or its successor. This includes the effects of changes such as Braking, steering, Visibility, and the addition of removable accessories.

After the manufacturer or its successor approves the modification or change, The capacity name plate, Label, identification marks, operation and maintenance manual must be changed accordingly

Truck damage caused by not following Instruction will lose its warranty.

3.Introduction of the product

3.1 Model overview

This specification is for CBD-J series 1.8/1.8/2.0T tramp type electric pallet truck (follow as truck) .

The type is“CBD18J-Li2—18 load capacity is 1.8H” meet the requirement of JB/T8452-1996 《Battery forklift model establishment method》 ,“J” is the product code.]

3.2 Model

parameters

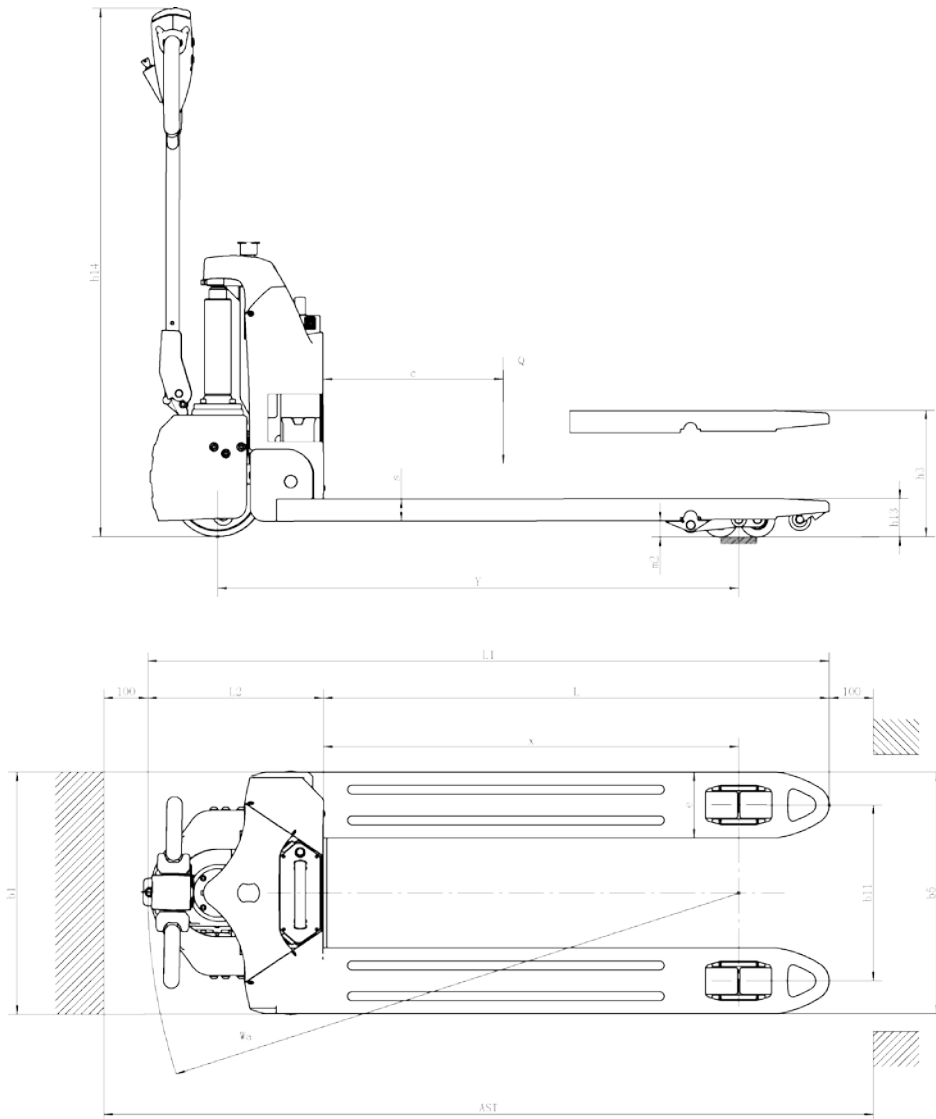

Mode		CBD15J-Li2	CBD18J-Li2	CBD20J-Li2
Drive type		Electrical	Electrical	Electrical
Manner of operation		Walkie	Walkie	Walkie
Load Capacity	Q (t)	1.5	1.8	2.0
Load Centre	c (mm)	600	600	600
Distance between fork backrest and front wheel	x (mm)	944	944	944
Wheel Base	y (mm)	1184	1184	1184
Service Weight (with battery)	kg	138	140	145
Tire material		PU	PU	PU
Driving wheel size	Φ×w(mm)	Φ210×70	Φ210×70	Φ210×70
Balance wheel size	Φ×w(mm)	Φ80×60	Φ80×60	Φ80×60
Qty of wheel, Front/Rear (x=driving wheel)		1x/4	1x/4	1x/4
Tread	b11 (mm)	400/535	400/535	400/535
Lifting Height	h3 (mm)	200	200	200
The height of handle in the operation position	h14 (mm)	830/1120	830/1120	830/1120
Lowered fork height	h13 (mm)	85	85	85
Overall Length	l1 (mm)	1543	1543	1543
Body Length	l2 (mm)	393	393	393
Overall Width	b1/ b2 (mm)	550/685	550/685	550/685
Fork Size	s/e/l (mm)	50/150/1150	50/150/1150	50/150/1150
Fork Width	b5 (mm)	550/685	550/685	550/685
Ground clearance under mast	m2 (mm)	35	35	35
Aisle width for pallets 1000*1200 crossways	Ast (mm)	1760	1760	1760
Aisle width for pallets 1000*1200 lengthways	Ast (mm)	1810	1810	1810
Turning Radius	Wa (mm)	1355	1355	1355
Driving Speed, load/unload	(km/h)	4.2/4.5	4.2/4.5	4.2/4.5
Maximum gradeability load/unload	(%)	5/10	4/10	6/10
Brake Type		Electromagnetic	Electromagnetic	Electromagnetic
Drive Motor	(kW)	0.75	0.75	0.75
Lift Motor	(kW)	0.8	0.8	0.8
Battery, according to DIN 43531/35/36 A,B,C,no		no	no	no
Battery voltage/rate capacity	(V/Ah)	24/28	24/28	48/15
Battery Weight (±5%)	(kg)	6.8	6.8	7.5
Type of drive control		DC	DC	DC
Noise level	(dB(A))	≤70	≤70	≤70
Steering type		Mechanical	Mechanical	Mechanical

4.Operating principle

With battery as power producer and controlled by electrical and hydraulic, trucks can do some actions like walking, turning, pallet fork lift, etc.

Operating mechanism diagram:

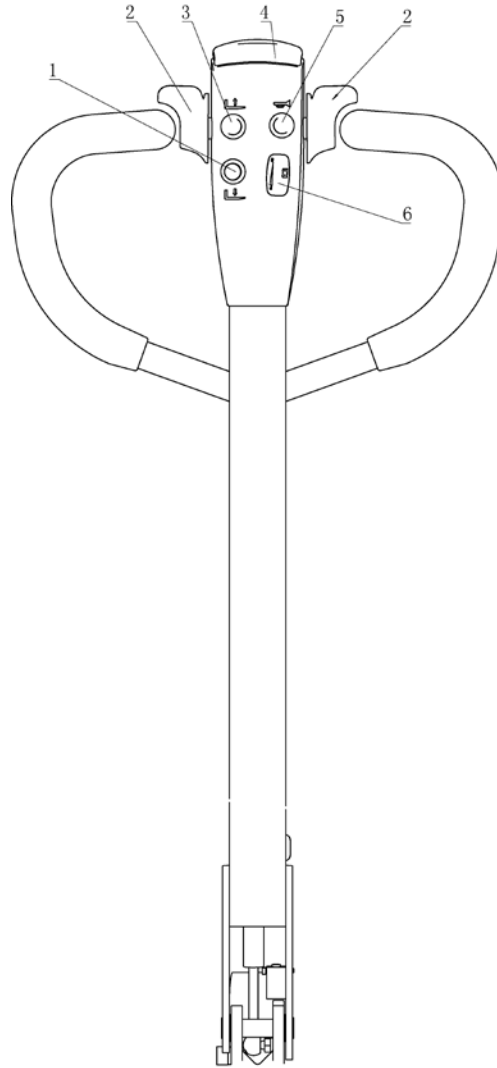

1.Falling knob

2.Driving button

3.Lifting button

4.Belly switch

5.Horn

6.Coulombmeter

5. Operating principle

5.1 Running system

The truck is powered by a battery, which is realized by controlling the AC motor on the drive wheel. The speed of walking is realized by frequency conversion control motor speed, which is controlled by the accelerator.

5.2 Steering system

The steering of the moving car is driven by the handle lever through the handle lever to drive the drive motor to realize the steering.

5.3 Brake structure and brake schematic diagram.

Braking performance depends on road conditions and vehicle load conditions.

5.3.1 The brake function can be activated by the following ways:

- Turn the travel switch (2) to "0" position or release the switch to make truck brake until it stops.
- With the driving switch (2) moving directly from one driving direction to the opposite direction, the vehicle regenerates the brake until it begins to move in the opposite direction.
- The handle moves up and down to the braking area (' B ') and the vehicle brakes. If the handle is released, the handle automatically moves to the upper braking area (' B ') and the vehicle stops until it stops.
- Belly switch (4) can prevent the operator will be squeezed, when vehicles are driven towards (' Fw) encounters an obstacle, body touch belly to slow down or start to switch vehicles (' Bw) driven a short distance, then stop. If the handle is in the operating area and the vehicle is not moving, please consider that this is still working.

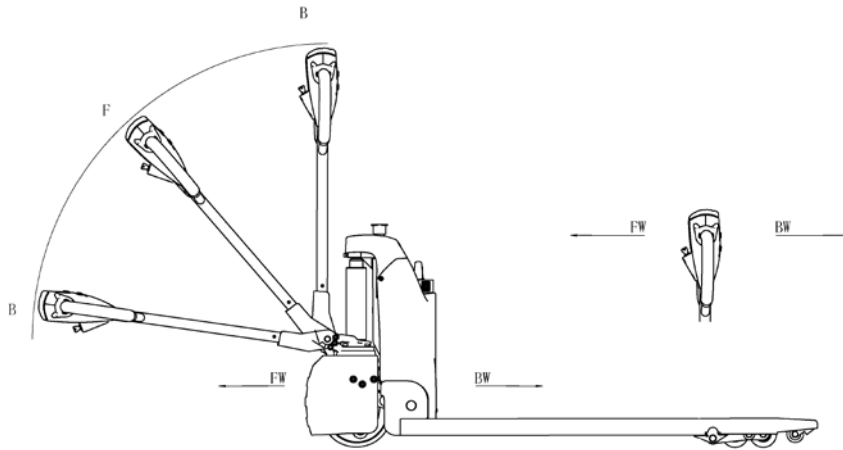

5.3.2 Braking operation principle:

As follow picture: The brake constitute by 1、 bolt 2、 magnetic yoke 3、 spring 4、 hollow bolt 5、 flange 6、 guide pillar 7、 mounting screw 8、 O-rings 9、 magnet exciting coil and so on. The brake is mounted on the drive rack and adjusts the mounting screw to the specified air gap value.

When magnet exciting coil 9 for brake on power, The coil generates a magnetic field to draw the hollow bolt 4 to the magnetic yoke 2, hollow bolt 4 is separated from the brake disc (release). Magnet exciting coil generates a magnetic field to absorb the magnetic magnetic yoke 2, which separates the hollow bolt 4 from the brake disc. At this moment, the motor will start and operate normally with the brake disc. When the magnet exciting coil 9 is off, the flux disappears and the hollow bolt 4 is released, Spring 3 puts pressure on hollow bolt 4, The friction plate of the brake disc on the hub motor is pressed tightly and the friction force is produced to achieve the braking purpose.

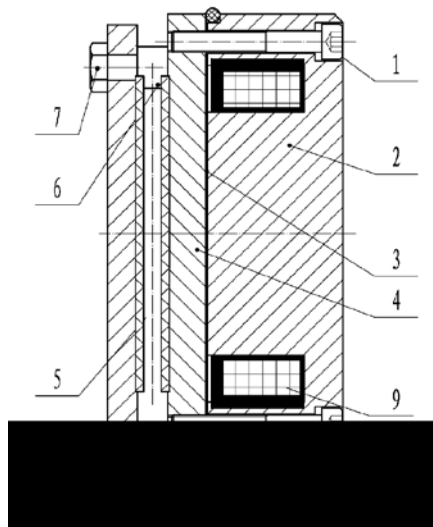

Brake schematic diagram

5.4 Operating System

The main working body of a moving truck is a cargo fork, which relies on a fork to carry the pallet or cargo for transport and short distance transportation. The expansion of the cylinder is realized by the control of the operating handle, and the pressure oil is provided by the pumping station.

5.5 Electric System

The electrical system includes walking and operation control. The truck use DC electric control assembly.

The meter has a battery indicator. When the battery power is too low, the electric meter will cut off the starting control line of the oil pump motor. The moving truck can only walk without lifting the fork, and the prompt should be charged immediately. The motor of oil pump is the dc motor for 5 minutes, so the pump motor is not suitable for long running. That is, the lifting movement should have time interval, can not continuously carry on, otherwise would make the motor heating, even burn.

Special note: when the truck is used for a long time, the starter of the oil pump motor may fail, and it can't be broken after being sucked or closed. The latter is not throw control handle, the oil pump motor is kept in the rotation, should immediately stop at this moment, to cut off the power supply (unplug battery plug-in), make the oil pump motor stop running, and promptly replace the starter.

5.6 Hydraulic principle

The oil pump motor drives the gear pump to provide hydraulic power ,lifting oil cylinder is responsible of fork's lifting and lowering, The control of the lift oil road is controlled by the buttons on the operating handle, The lifting action is controlled by a single action oil circuit on the valve block. This model of the hydraulic system pressure can only be adjusted on the valve block, has been debugging good, before they go out after they leave the our company after-sales personnel or professional maintenance personnel are strictly forbidden to adjust themselves, so as to avoid safety accident.

6. Electrical schematic diagram

6.1 Electrical schematic diagram

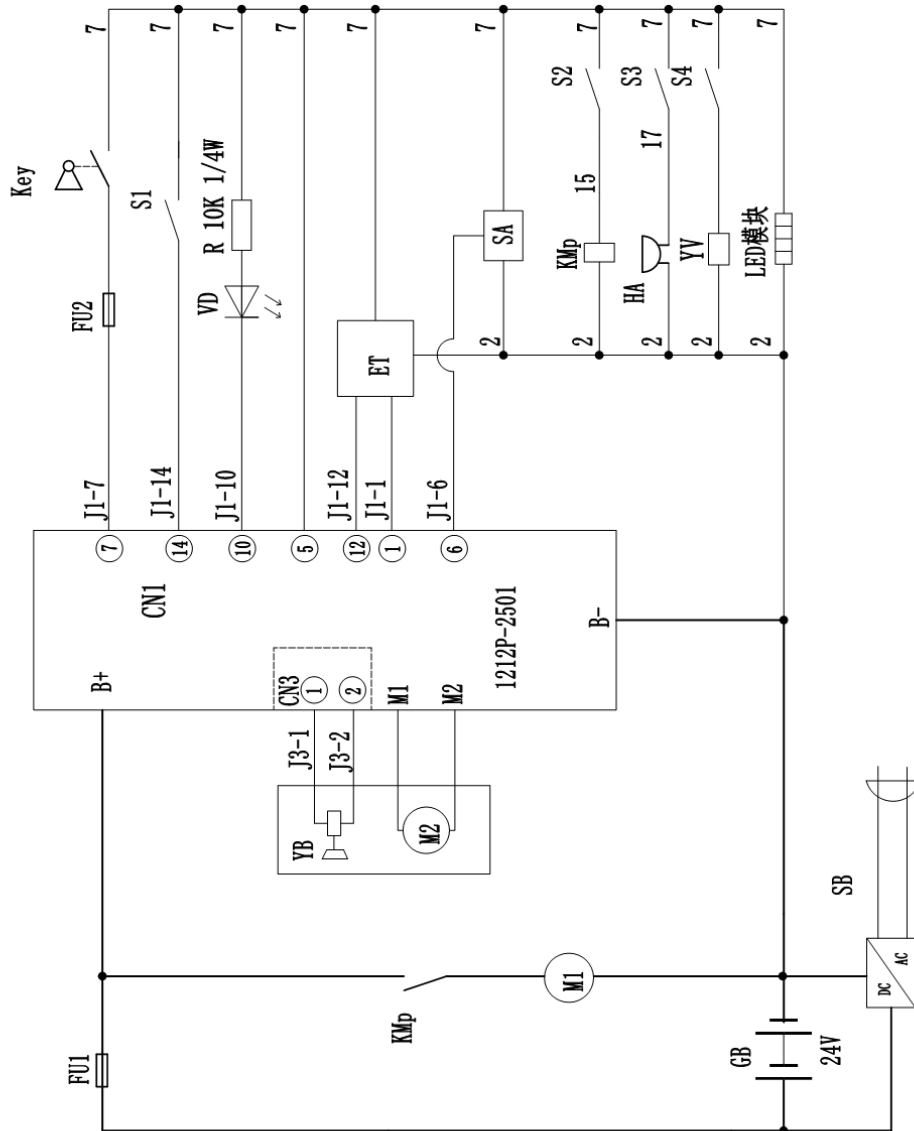

1.5t/1.8t

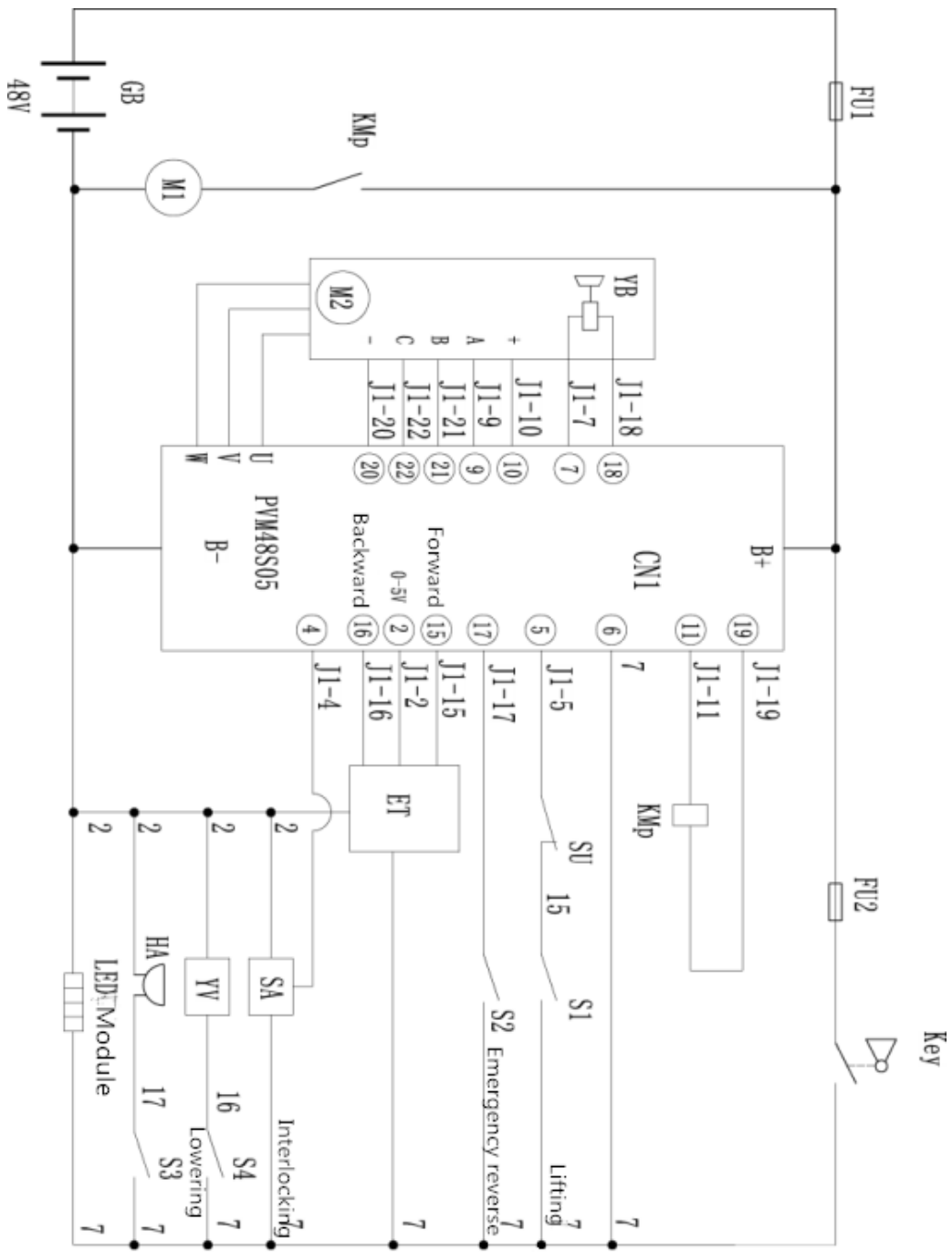

2.0t

7. Hydraulic Scheme

7.1 Hydraulic Scheme

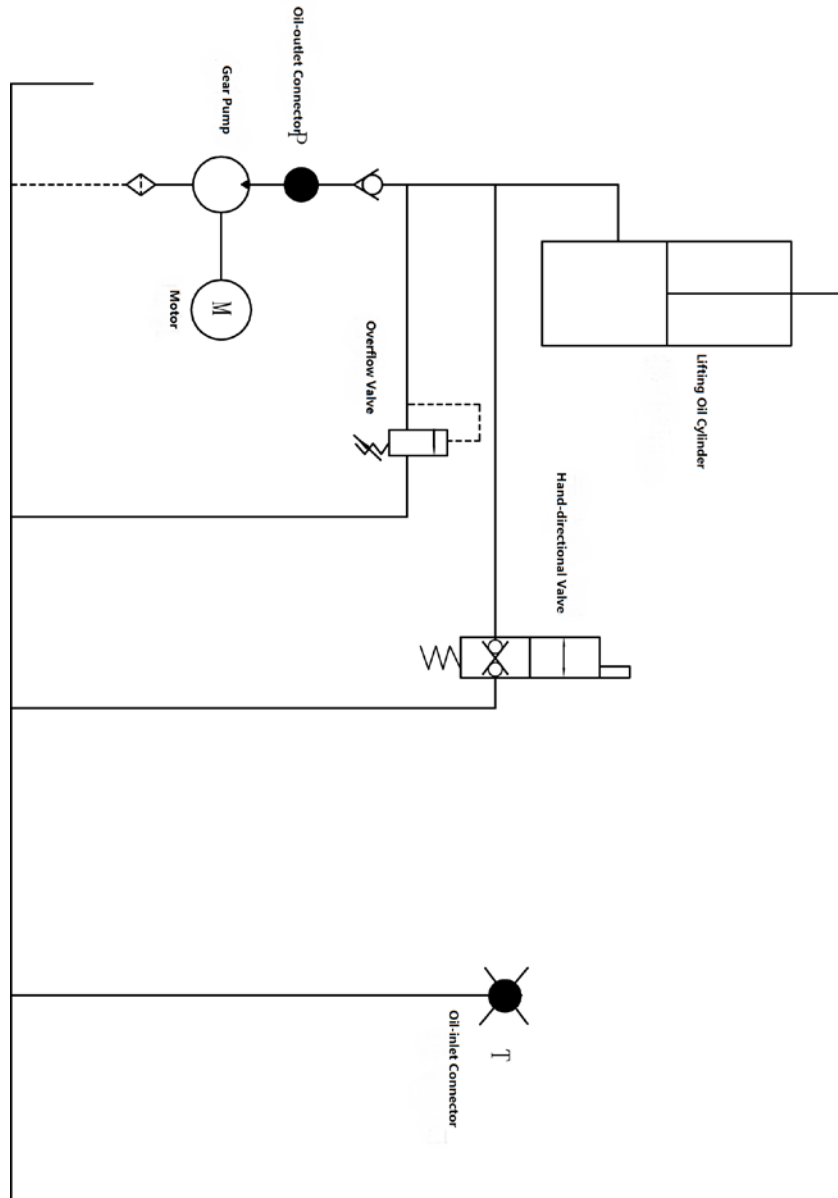

8.Operating Instruction

Before operation, please familiarize yourself with the functions of the switches and buttons on the dashboard.

8.1 Operation

- ①、 Plug in the li-ion battery interface
- ②、 Open the electric lock

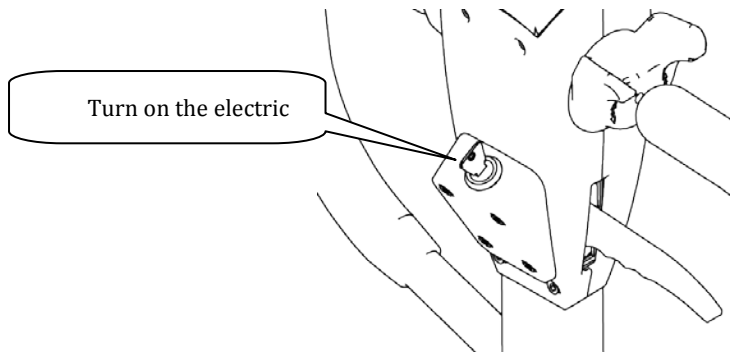

- ③、 Fork lifting and lowering:

Lifting: Control the lift button on the handle.

Lowering: Hold the drop knob.

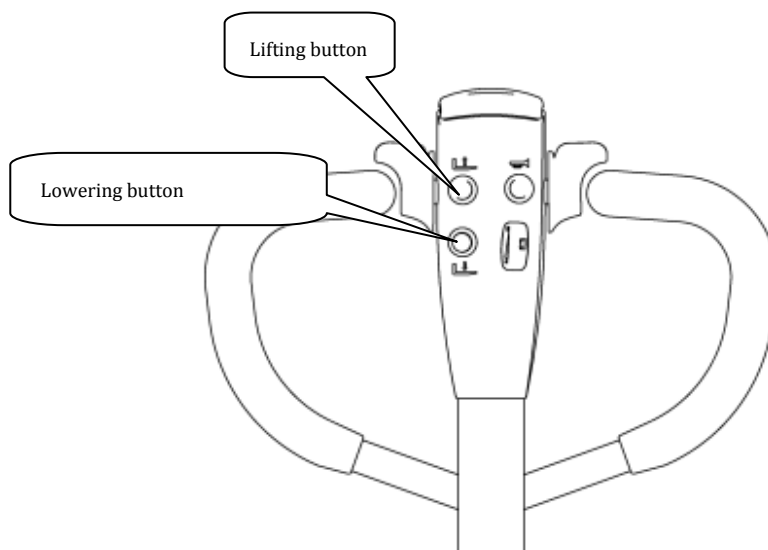

④、Driving

Rotate the handle to the driving range;

A and C is brake range;

B is driving range;

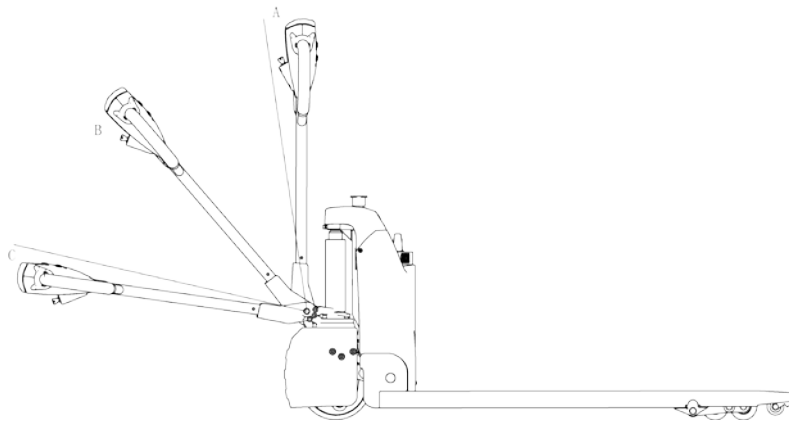

Slowly rotate the accelerator to start the truck. (In order to be safe, fast acceleration is prohibited.)

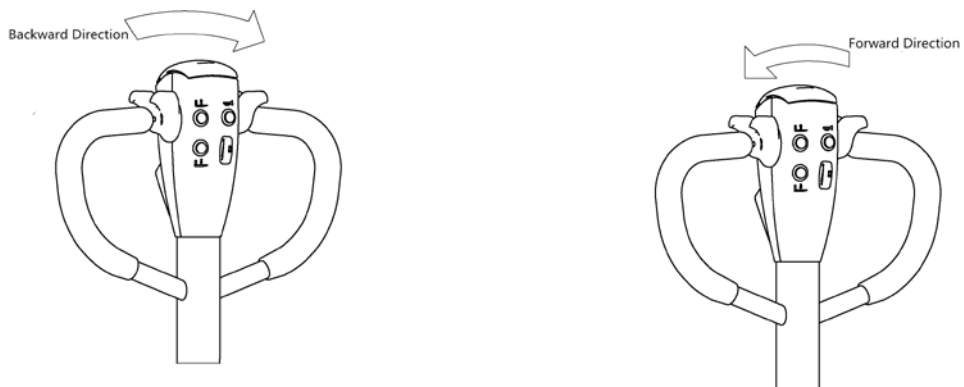

⑤、Brake

When the accelerator is released normally, the truck will stop until the brake is held in the car through the regenerative braking of the motor.

When emergency braking, the operating handle is quickly turned to zone A or area C (figure 9), and the brake is carried to the death to realize the emergency braking function.

⑥、Parking

Release the acceleration button to stop the moving truck and slow down the vehicle until the brakes are on.

Lower the fork to the lowest position. Turn off the electric lock.

Park for a long time, then the battery power cord is pulled out.

8.2 Emergency reverse function

The red button at the end of the handle is the emergency reverse button. When the body is in contact with the emergency reverse button, the vehicle will stop immediately and drive backward for a distance. This is a safety switch designed to prevent the vehicle from being crushed when the operator encounters an obstacle.

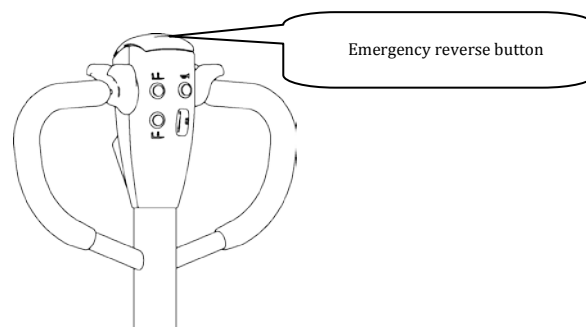

8.3 The use of the horn and the reversing horn

In order to drive safely, the truck is equipped with a driving horn. To remind others when driving, press the horn button in the middle of the handle handle, and the horn will ring to warn pedestrians.

8.4 Battery capacity display

The battery capacity of the forklift truck on the dashboard has capacity display function.

8.5 operation

(1) How to carry goods

Will truck slowly drive to the front of the need to carry items, insert the pallet fork and move forward slowly, when the goods completely inserted into the goods after parking, control handle upgrade button, the heavy lifting to a certain height, back slowly, don't touch the adjacent goods, when the weight zone is put out the goods, and then walk handling.

(2) How to place the goods

When moving the goods close to the area of the goods, it will slow down. When the moving truck is in a straight line with the goods, then the moving truck will slowly move forward to the loading area to stop. Slowly press the down button, and once the load is held, the fork will be lowered to the hollow position. When the fork is pulled out of the weight, the back position will be confirmed without any obstacle. Wait for the fork to leave the weight completely before carrying on a round of handling.

9.Safety operation and matters needing attention

The spare parts of the truck is not allowed to change without permission. All parts supplied by the original manufacturer are subject to strict quality inspection. To ensure the safety and reliability of the vehicle, please use the original parts. Replacement parts, including all oils, must be collected and processed in accordance with local environmental and health laws and regulations.

9.1 Repair and Maintenance

Maintenance technician: The maintenance and service should only be performed by special personnel trained by the manufacturer. After the technician sent by after-sales department of the manufacturer completed maintenance and servicing work, they should sign on the service log.

Cleaning Operation: Flammable liquid can not be used for cleaning the stacker. Before cleaning, take safety precautions to prevent electric sparks (e.g. sparks caused by short circuit). When operating the accumulator, connectors on it must be disconnected. Use soft air suction or compressed air, non-conductive and anti-static brushes to clean electric and electronic components.

Operation of Electric System: Operation on the electric system should only be performed by specially trained personnel. Before performing any operation on the electric system, precautions must be made to prevent electric shock. When operating the accumulator, connectors on it must be disconnected.

Installation: When repairing or replacing hydraulic components, electric and electronic components, make sure to install them back to their original positions.

Wheels: Quality of the wheels has significant effect on stability and driving performance of the truck. Modification on wheels can be performed only with the approval from the manufacturer. When replacing wheels, ensure that the truck is leveled as delivery state(wheels must be replaced in pairs, i.e. replace right wheel together with left one).

Lifting chain and rollers: Chain and rollers will be worn quickly without good lubrication. Perform periodic lubrication according to following maintenance table. Shorten the lubrication period under adverse operation conditions (such as in dusty and hot environment).

Hydraulic oil pipe: The oil pipe must be changed every 6 years. When change the hydraulic assembled parts, the oil pipe should be also changed.

9.2 Routine Maintenance

9.2.1 check the condition of each pole, cable and protective cover of the accumulator.

9.2.2 check whether the battery box is secure.

9.2.3 check whether the vehicle is oiled.

9.2.4 check the situation of fork, oil pipe and horn.

9.2.5 check the braking condition.

9.2.6 check the wear condition of driving wheel, load wheel and so on.

9.3 Professional Maintenance Manual

It is very important for safe operation of the truck to perform overall professional maintenance. Failure in performing maintenance according to specified interval may cause malfunction of the truck, and potential risk to human and equipment.

Maintenance periods listed in this manual apply to single shift a day under normal operation conditions. If using in dusty environment, the ambient temperature varies remarkably or in multi-shift situation, the maintenance period has to be shortened.

Maintain the truck according to following maintenance list. Maintenance periods are as follows:

W1 = Every 50 work hours, but at least once a week.

M3 = Every 500 work hours, but at least once every three months

M6 = Every 1000 work hours, but at least once every six months

M12 = Every 2000 work hours, but at least once every 12 months

Additional operations should be performed in trial run period:

(In initial 50 – 100 working hours or after two months)

— Check the nuts on the wheels, and tighten them if necessary.

— Check the hydraulic components for leakage, and tighten them if necessary.

— Replace the hydraulic filter.

Maintenance			Maintenance time interval●			
			W	A	B	C
Brake	1.1	Check the air gap of electromagnetic brake			●	
Electric System	2.1	Check switch operation, display the function of the equipment and	●			
	2.2	Check the alarm system and safety device		●		
	2.3	Check whether there is any damage on the cable and terminal is rigid			●	
	2.4	Check the function of the micro switch Settings	●			
	2.5	Check the controller and EPS controller			●	
	2.6	Fixed cable and motor			●	
Energy Supply	3.1	By observing the battery		●		
	3.2	Visual inspection battery charging plugs			●	
	3.3	Check whether the battery cable connection fastening, if necessary, with oil			●	
Traveling System	4.1	Check if have gearbox abnormal sound			●	
	4.2	Check the travel agency, and the oil, check the reset function of operating		●		
	4.3	Check the drive wheels and bearing wheel for wear and damage			●	
	4.4	Check the wheel bearing and fixed			●	
Massive Structure	5.1	Check whether the framework has damaged			●	
	5.2	Check whether the sign is complete			●	
	5.3	Check the door frame fixed situation			●	
The hydraulic system	6.1	Check the function of the hydraulic system		●		
	6.2	Check the hoses, pipes and interface whether fastening, sealing and presence		●		
	6.3	Check whether the damaged piston and cylinder . sealed and fixed			●	
	6.4	Check the load chain Settings.			●	
	6.5	Visual inspection door frame and check on the surface of the roller of roller			●	
	6.6	Check the goods fork teeth and load parts for wear and damage			●	
	6.7	Check the tank oil level			●	
	6.8	Update the hydraulic oil				●

9.4 battery maintenance, charging and maintenance.

Any operation of the battery must be guaranteed to stop the vehicle and put it in a safe position.

9.4.1 maintenance personnel.

Battery charging, maintenance and replacement must be operated by qualified professionals. You must carefully read the manual, supply preparation and charging requirements before preparing for the operation.

9.4.2 fire protection measures.

Smoking and open fire are strictly prohibited when operating the battery. Storage battery and charge must be kept away from combustible materials, at least 2 meters above the distance, the place of storage battery must be well ventilated and equipped with fire-fighting facilities.

9.4.3 Battery type and usage note.

①、 The battery type of the car is: lithium ion battery; Battery voltage 48V; This battery belongs to environmental protection battery, without chemical mercury and cadmium.

②、 Matters needing attention:

A) the battery USES the temperature environment -10 ~ 45;

B) the battery shall be charged and discharged once every three months during the long period of suspension;

C) before using the new battery, or for the first time after storage, please recharge the battery before use;

D) do not short-circuit the battery, which may permanently damage the battery;

E) do not burn or destroy batteries, which may cause the release or explosion of toxic gases;

F) do not directly weld the battery;

G) do not allow the battery to be in a hostile environment, such as extreme temperature, deep cycle, or frequent overcharge/discharge;

H) if the battery is hot, do not touch, until cooling;

I) when removing the battery pack, hold the plug with your hand instead of pulling the cord;

J) after the battery is used, if the battery is hot and before recharging, please cool in the ventilated environment;

K) do not put batteries in water or seawater;

L) do not try to separate, squeeze, impact the battery, the battery will heat or fire, the lye in the battery will be harmful to the skin and eyes, and will damage the clothes;

M) keep the battery away from children.

9.4.4 Disposal of used batteries.

Scrap battery must be carried out in accordance with the relevant laws and regulations in region recycling, storage provisions stipulated by the environmental protection area or waste treatment area, and the work must be conducted by qualified professional company.

9.4.5 Specification of the accumulator

Battery		Charger	
Rated Voltage:: 24V	Rated Capacity: 28Ah	Input: 195/265VAC 50/60Hz	Output: DC24V10A
Rated Voltage:: 48V	Rated Capacity: 15Ah	Input: 195/265VAC 50/60Hz	Output: DC48V5A

Uninsulated terminal poles on the accumulator should be protected with an insulated cover. When connecting the accumulator and socket, make sure to stop the device and put the switch at position "0".When replace or install the accumulator, make sure the accumulator is fixed securely in battery box.

9.4.6 Storage, transportation and installation of the accumulator

The device must be parked on the level ground steadily. To prevent short circuit, naked cable ends and the terminal posts should be covered with insulated covers. When pulling out the accumulator, properly arrange removed accumulator's connectors and cables without blocking access of the accumulator.

9.4.7 Battery power indicator

Battery power display table: ten article showing represent 100% of the battery.

With the consumption of battery capacity, the glowing article shows will be from top to down.

The color of LED show the different states:

Name	LED Color	Parameter value
The standard battery remaining power	Green	70-100%
	Orange	30-60%

	Red blinking	0-20%
--	--------------	-------

Battery discharge on 70%,red lamp will blinking “Energy storage”.

Battery discharge on 80%,two lamp will blinking“ run out of battery” ,Need to charge the accumulator.

9.4.8 Charging

Read the instruction manual carefully before recharging.

- a) Must use Li-ion Charger specially designed by our company, Charger operating voltage 48V, maximum charge up voltage 54.6v, charging current 3A
- b) Do not reverse charge the battery
- c) Stop charging immediately when battery has obvious heat during charging .Then cool it before charging
- d) Please hold the handle when pulling charger connector, direct drawing of wire is not allowed

9.4.9 Disassembly and Installation of battery

Parking the truck before the battery is removed and installed

Disassembly & Installation battery step:

- A: Turn off the car.
- B: Pull the power connector handle and unplug the power connector(Attention: When pulling the power connector, Must hold the handle .Please do not pull the wire directly
- C: Pull up the battery and pull the battery out of the car.
- D: Insert the new battery into the battery mounting solt.
- E: Plug in the power connector.

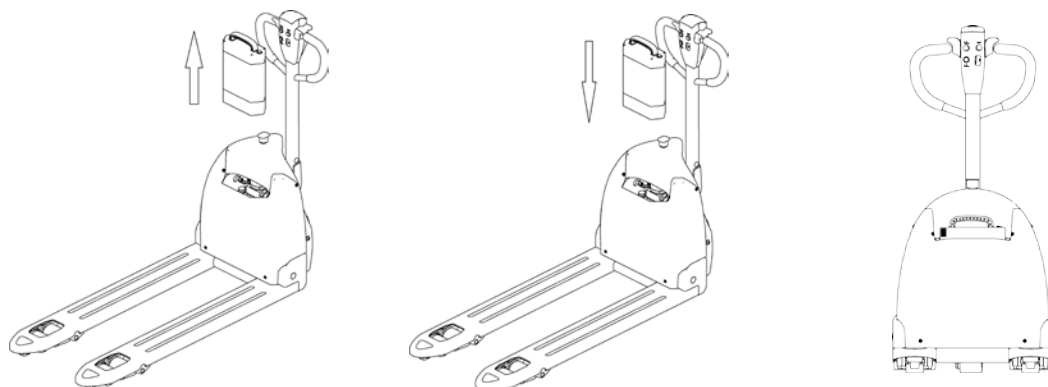

10.Safety Caution

10.1 General rule

10.1.1 The operator must have a forklift operation qualification which proved by the relevant departments of the training before driving truck.◦

10.1.2 The operator must read the instructions before use all of the content, after fully understand operation method can drive Truck.

10.1.3 truck must not carry passengers.◦

10.1.4 Operators should pay special attention to when homework operating environment, including other people nearby and fixed object.

10.1.5 Without the manufacturer's approval, shall not modify, add or remove tractor parts, lest affect performance of tractor.

10.2 Storage and transportation

10.2.1 Use container or car should pay attention to at the time of shipment:

⊙ Front and rear wheels with wedge, begin to pull up the parking system, prevent sliding in the process of transportation;

⊙ Using the lasso, not placed in the weak structure of the truck;

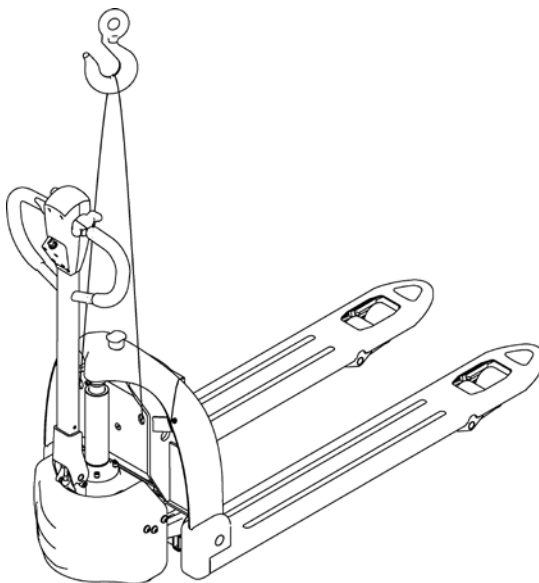

③ When moving the truck. Pay attention to keep the center of the moving truck in the middle of two fork

④ During Transportation, Remove the Trailer and fix the tractor with a dedicated strap for lifting according to the figure below.

10.2.2 When Truck doesn't work, should be parked in a dry ventilated cleaning warehouse, prevent weathered.

And please note:

① Turn off the Electrical lock and make the safety switch off, unplug the power plug

② Begin to pull up the parking system, front and rear wheels with block mat;;

③ Such as discontinued for a long time, battery should be added once every 15 day electricity.

10.3 Check before using

10.3.1 New car if there is any damage in transportation, please don't be put into use, and promptly get in touch with the supplier, do proper processing.

10.3.2 New cars in the factory run parts has been filling lubricating oil.

10.3.3 Truck equipped with battery. The battery is charged before leaving factory. If leaving the factory for a long time, may the battery is low. Before use should pay attention to electricity meter shows that when the electricity meter display to the last two warning, must charge at once. Every day before using, or before charging, should open the battery blocks, check the liquid level height, such as liquid level is too low to add distilled water in charge. Detail as (Battery charging and maintenance

10.4 Safety operation regulation

10.4.1 Requirement for operator: The Truck must be operated by a trained operator, He can perform and operation demonstration on the user to move and mainpulate the cargo, and can clearly guide the user how to operate the forklift.

10.4.2 Operator's rights, obligations and responsibilities: Has been trained by the operation of the vehicle, the driver must be clear of his rights and obligations; and he is

familiar with the contents of the relevant operating instructions. If the vehicle is pedestrian type, the driver must also wear safety boots.

10.4.3 Prohibit unauthorized person to operate: The operator is responsible for the vehicle, he need to prohibit unauthorized person to operate. Transport or lift person is also forbidden.

10.4.4 Malfunctions and defects: If the vehicle has any malfunctions or defects, need to inform administrator, If the vehicle cannot be safely operated (e.g.: wheel wear or brake failure), then it must stop using until it is fully repaired.

10.4.5 Safe operation and environmental protection: inspection and maintenance must be performed in accordance with the time intervals on the maintenance list.

Parts of the vehicle cannot be changed without any permission, especially safety devices. The operating speed of the truck is not allowed to change.

All original spare parts have been verified by quality assurance department. To ensure the safety and reliability of the operation of the truck must use only the manufacturer's spare parts. The old parts, such as oils and fuels must be handled in accordance with the relevant environmental protection rules.

10.4.6 Hazardous area: Hazardous area usually refers to the following range: vehicle or its load lifting devices (e.g. fork or accessories) is dangerous for personnel when running or lifting movements, or the ongoing regional transport loads. Typically, this range extends to the load or truck accessories landing area.

Unauthorized personnel must be asked to leave the dangerous zone. As long as the situation might cause some kind of damage, the driver must give a warning, if the driver asked the person to leave but did not leave the hazardous zone, the driver must immediately stop the vehicle.

10.4.7 High-risk environment: Working in high-risk environment, operator must have a special design to be protected.

The vehicle was not specially designed for the high-risk environment.

10.4.8 Safety devices and warning signs: Safety devices, warning signs and warning notes described in the previous operating instructions must be taken seriously enough.

10.4.9 Driving in public places: the vehicle is forbidden to drive in public places except in specified special areas.

10.4.10 Distance between truck: keep an appropriate distance, avoid the front vehicle suddenly stop.

10.4.11 headroom: When the headroom is below the cargo or mast, it is forbidden to use the vehicle.

10.4.12 Using in the elevator and loading platform maneuvering: if there is sufficient loading capacity, won't affect the operation of the vehicle, and being agreed by the operator of the vehicle, then the elevator and loading platform can be used for vehicle transport. Before entering the elevator or loading station, operator must personally identify. The goods must be placed in front and occupy an appropriate place, to avoid touching the wall of the elevator when the vehicle enters the elevator. When personnel and vehicles take the elevator together, person can enter only after the vehicle has safely entered, and person must leave before the vehicle.

10.4.13 Driving aisle and working area: The vehicle must be operated on the specified aisle, all non-related person must leave the work area, and cargo should be stacked in designated places.

10.4.14 Operation Management: Driving speed must be adapted to local conditions. When through the corners, narrow passage, swing doors and closed place, speed must be slowed down. Drivers must be able to visually an adequate braking distance between vehicle and the front vehicle, and he must remain in control of his vehicle. Sudden stop (unless urgent needs), rapid U-turn, chased each other in the Aisle is not allowed. Do not pry out of the body to operate the vehicle.

10.4.15 Visibility: The driver must look attentively at the direction of driving, to ensure the front situation is clearly visible. When the vehicle is backing off, if the carriage of goods block

the line of sight, a second person walk in front of the vehicle to give appropriate guidance and warnings is necessary.

10.4.16 Pass through the ramp: Only a known ramp which should be clean, non-slip, and with the vehicle technical availability was allowed to go through. The goods on the forks must face uphill. It is forbidden to turn back, move diagonally or park on the ramp. The operator must slow down when going through the ramp, and prepare to brake at any time.

10.4.17 Load capability on ground: when the vehicle is in operation, make sure the load pressure of the body weight or wheels on the ground does not exceed the load capacity of the ground .

10.4.18 Vehicle Change: Any possible changes or modifications for rated load, stability or safe operation of the vehicle, must obtain prior written approval from origin manufacturers or its successor. After vehicle manufacturer check and approve the changes, nameplates, labels and markings of Operation and Maintenance Manual must be modified as well.

11.Service Manual

11.1 Troubleshooting

Fault	Cause	Treatment
The truck can't move	The battery connector is not connected	Check the battery connector, connected if necessary
	Electric lock switch on "OFF" position	Electric lock switch turn to "0" position
	Emergency Stop Switch not open	Open the Emergency stop switch
	Battery power runs out	Check the battery charge, If it is necessary to recharge
	The vehicle being charge	Interrupt charging process
	The fuse is damaged	Check the fuse
Goods can't be lifted up	The vehicle is not operating	Handle according to the treatment method listed in Vehicles cannot move"
	Low hydraulic oil level	Check hydraulic oil
	The fuse is damaged	Check the fuse
	Overloading	Pay attention to the rated capacity
	The Up switch is in bad contact or damaged	Check up switch and replace if necessary
Goods can't be lowered down	Dirty oil blocks control valve	Check hydraulic oil and clean control valve, replace the oil if necessary
	The solenoid valve for lowering is not opened or is damaged	Check or replace the valve for lowering
Can't stop when lifting	Lifting micro switch is damaged	Cu off the power and replace lifting micro switch
Moving in one direction	The sensitive switch and the connecting cable are not well-contacted.	Check the sensitive switch in control lever and the connecting cable.
The vehicle travels very slow	The related cable are not well-connected	Check the battery indicator light and related cable
The car suddenly started	Controller is damaged.	Change the controller
	The handle which control the forward or back is no reset.	Repair or change

If above steps still can not solve problems, please contact after-sales service department of the manufacturer and have the problems solved by specially trained technicians.

11.2 Preparation before repair

To prevent possible accidents during maintenance and repair work, following preparations must be done:

- Park the device safely.
- Press the emergency stop switch and disconnect the connectors on accumulator.

11.3 Check the amount of hydraulic oil

- A vehicle ready for repair or maintenance。
- Open the electrical box cover。
- Check the amount of hydraulic oil in the tank。

When checking the hydraulic oil level, the fork and mast must be lowered to the lowest position.

11.4 Complete repair, the preparation before using

Use the device only after following operations have been completed.

- Clean the vehicle
- Check the brake.
- Check the emergency stop switch.。
- Check the horn.

Several electromagnetic brake tests need perform immediately after the test