

**CDD14-ES CDD16-ES**  
**STAND-ON PALLET STACKER**  
**OPERATION MANUAL**

HANGCHA GROUP CO.,LTD

## Foreword

Thanks for your purchasing our forklift truck.

CDD14-ES is our company's new product. This manual is about how to use, operation and maintenance . Please operator and whom in charge of the truck must read the manual carefully before operate the truck.

We have the right to improve the truck, maybe there are some difference between your product and the description in this manual.

If you have any questions please keep in touch with the sales department of E-P Equipment or let the dealer know.

HANGCHA GROUP CO.,LTD

Address: NO.88 Donghuan Road, Economic Development Zone, Lin'an, Zhejiang, China

Tel:86-571-88926752/88926755/88926733

Fax:86-571-88926789

Net: [www.hcforlift.com](http://www.hcforlift.com)

Email: [whsales@hcforlift.com](mailto:whsales@hcforlift.com), [sales@hcforlift.com](mailto:sales@hcforlift.com)

**ALL RIGHT RESERVED COPYRIGHT @2010.1 1<sup>st</sup> EDITION**  
**HANGCHA GROUP Co.,Ltd**

## **WARNING!**

### **TO PREVENT SETIOUS RISK OF INJURY TO YOUORSELF AND OTHERS OBSERVE THE FOLLOWING SAFETY INSTRUCTIONS.**

These truck may become hazardous if adequate maintenance is neglected. Therefore, adequate maintenance facilities, trained personnel and procedures should be provided.

Maintenance and inspection shall be performed in conformance with the following practices:

1. A scheduled planned maintenance,lubrication and inspection system should be followed.
2. Only qualified and authorized personnel shall be permitted to maintain, repair, adjust, and inspect truck.
3. Before leaving the truck:
  - Do not park the truck on an incline.
  - Fully lower the load forks.
  - Set the key switch (4) to the "OFF" position and remove the key.
  - Drawing back the emergency brake switch (11).
  - Fold in the folding side arm
4. Before starting to operate truck:
  - Be in operating position
  - Place directional control in neutral
  - Before operating truck, check functions of lift systems, directional control,speed control,steering, warning devices and brakes.
5. Avoid fire hazards and have fire protection equipment present. Do not use open flame to check lever, or for leakage of electrolyte and fluids or oil. Do not use open pans of fuel or flammable cleaning fluids for cleaning parts.
6. Brakes,steering mechanisms, control mechanisms,guards and safety devices shall be inspected regularly and maintained in legible condition.
7. Capacity, operation and maintenance instruction plates or decals shall be maintained in legible condition.
8. All parts of lift mechanisms shall be inspected to maintain them in safe operating condition.

9. All hydraulic systems shall be regularly inspected and maintained in conformance with good practice. Cylinders, valves and other similar parts shall be checked to assure that "drift" has not developed to the extent that it would create a hazard.

10. Truck shall be kept in a clean condition to minimize fire hazards facilitate detection of loose or detective parts.

11. Modifications and additions which affect capacity and safe truck operation shall not be performed by the customer or user without manufacturers prior written approval. Capacity, operation and maintenance plates or decals shall be changed accordingly.

## catalog

<b>Correct use and application .....</b>	<b>1</b>
<b>1. Truck Description .....</b>	<b>2</b>
1.1 Assemblies .....	2
1.2 Identification points and data plates .....	5
1.3 Specifications .....	7
<b>2. Transport and Commissioning.....</b>	<b>9</b>
2.1 Transport .....	9
2.2 Using the Truck for the First Time .....	9
2.3 During brake-in .....	10
<b>3. Operation .....</b>	<b>11</b>
3.1 Safety Regulations for the Operation of Forklift Trucks .....	11
3.2 Starting up the truck.....	11
3.3 Safety regulations for truck operation .....	15
3.4 Collecting and depositing loads .....	16
<b>4. Battery Maintenance &amp; Charging .....</b>	<b>17</b>
4.1 Safety regulations for handling acid batteries .....	17
4.2 Battery type & dimension.....	18
4.3 Charging the battery .....	18
4.4 Battery removal and installation .....	19
<b>5. Forklift Truck Maintenance .....</b>	<b>21</b>
5.1 Operational safety and environmental protection .....	21
5.2 Maintenance Safety Regulations .....	21
5.3 Servicing and inspection.....	22
5.4 Decommissioning the industrial truck.....	28
5.5 Safety checks to be performed at regular intervals and following any unusual incidents .....	29
5.6 Final de-commissioning, disposal .....	29
<b>6. Troubleshooting .....</b>	<b>30</b>

## **Correct use and application**

The “Guidelines for the Correct Use and Application of Industrial Trucks” (VDMA) are supplied with the truck. The guidelines form part of these operating instructions and must be observed. National regulations apply in full.

The truck described in the present operator manual is an industrial truck designed for lifting and transporting load units.

It must be used, operated and serviced in accordance with the present instructions. Any other type of use is beyond the scope of application and can result in damage to personnel, the truck or property. In particular, avoid overloading the truck with loads which are too heavy or placed on one side. The data plate attached to the truck or the load diagram are binding for the maximum load capacity. The industrial truck must not be used in fire or explosion endangered areas, or areas threatened by corrosion or excessive dust.

### **Proprietor responsibilities**

For the purposes of the present operator manual the “proprietor” is defined as any natural or legal person who either uses the industrial truck himself, or on whose behalf it is used. In special cases (e.g. leasing or renting) the proprietor is considered the person who, in accordance with existing contractual agreements between the owner and user of the industrial truck, is charged with operational duties.

The proprietor must ensure that the truck is used only for the purpose it is intended for and that danger to life and limb of the user and third parties are excluded.

Furthermore, accident prevention regulations, safety regulations and operating, servicing and repair guidelines must be followed. The proprietor must ensure that all truck users have read and understood this operator manual.

Failure to comply with the operator manual shall invalidate the warranty. The same applies if improper work is carried out on the truck by the customer or third parties without the permission of the manufacturer’s customer service department.

### **Attaching accessories**

The mounting or installation of additional equipment which affects or supplements the performance of the industrial truck requires the written permission of the manufacturer. In some cases, local authority approval shall be required.

Approval of the local authorities however does not constitute the manufacturer’s Approval.

# 1. Truck Description

## 1.1 Assemblies

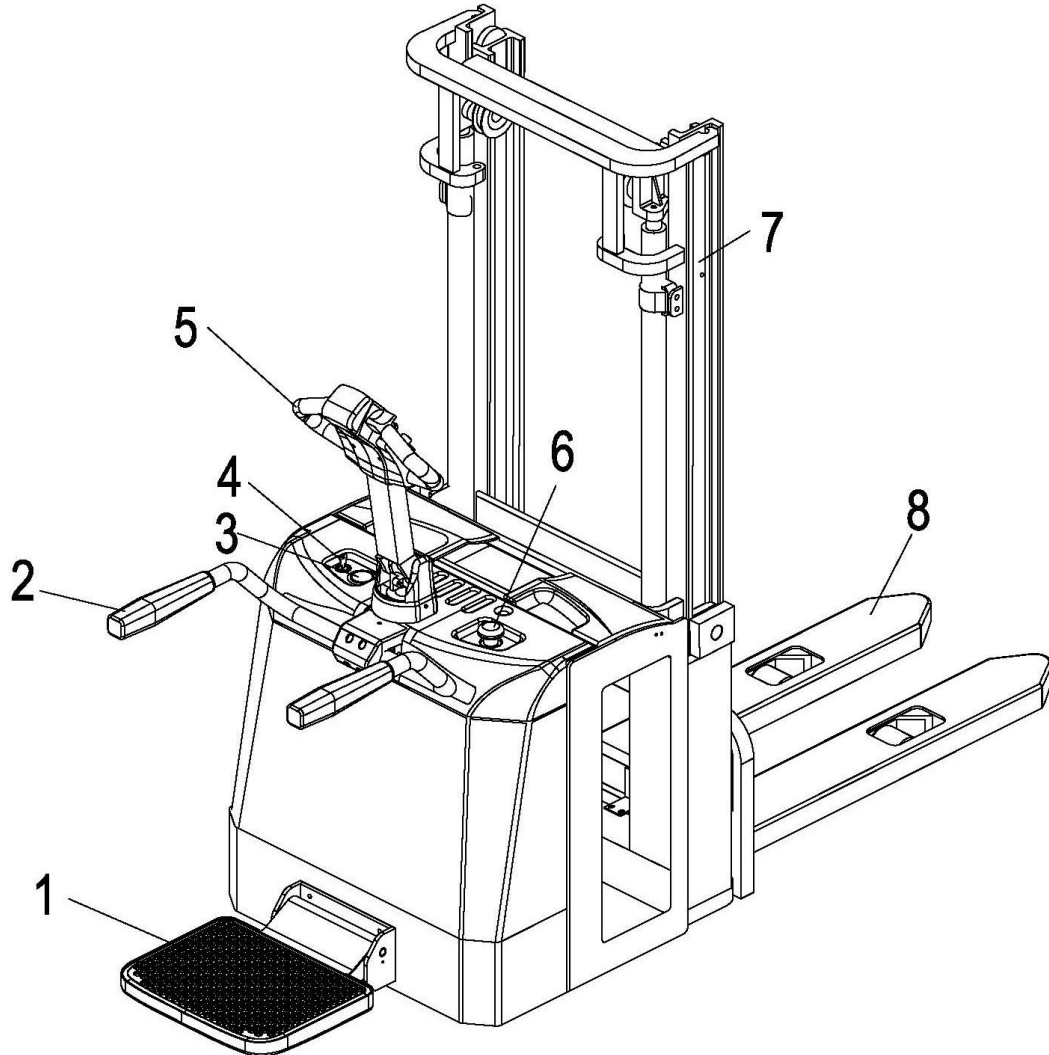

Item	Component	Item	Component
1	Folding operator pedal	5	Control Handle
2	Side arm	6	Emergency brake switch
3	Battery discharge indicator	7	Mast
4	Key switch	8	Lift mechanism

### 1.1.1 Folding operator pedal

Folding operator pedal have two state: fold and unfold. While the state of Folding operator pedal changed the Travel speed (Max) changed too. Because of gas spring the folding operator pedal can fold self-motion.

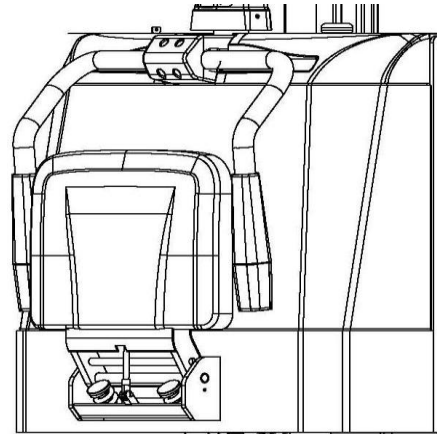

### 1.1.2 Side arm

Travel speed (Max) will change when the state of side arm is changed. Travel speed (Max) is much higher when the side arm is unfolded. The side arm can protect operator when truck running in high speed.

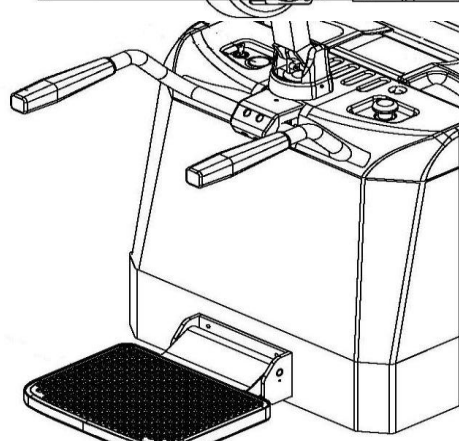

### 1.1.3 Battery discharge indicator

The LEDs (1) represent battery residual capacity, The LCD (2) displays the operating hours

#### Battery Discharge Indicator(1)

When the truck has been released via the key switch, the battery charge status is displayed.

The colours of the LEDs (1) represent the following conditions:

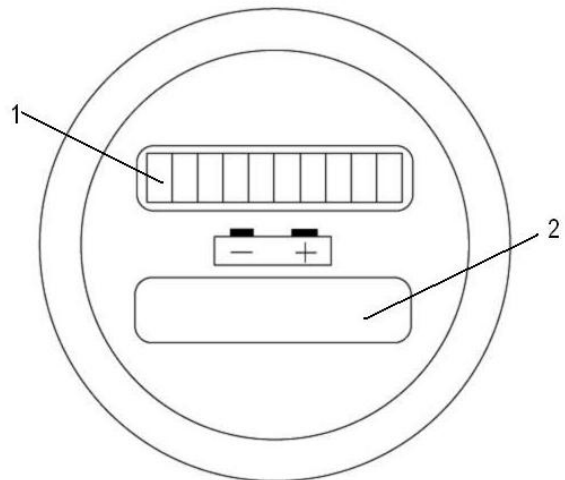

LED colour		value
Green	Standard battery residual capacity	70-100%
Orange	Standard battery residual capacity	50-60%
Flashing Red	Standard battery residual capacity	0-20%

Battery Discharge for 70%, A flashing red show on storage battery charge warning.

Battery Discharge for 80%, Two flashing reds show on battery charge used up warning, Lifting is now inhibited. The battery must be charged.

#### Operating hours display

Display range between 0.0 and 99,999.0 hours. Travel and lifting are logged. This is a backlit display.

#### Power up test



On power up the display shows:

- the operating hours
- the charge status

#### 1.1.4 Key switch

Switches control current on and off.

Removing the key prevents the truck from being switched on by unauthorised personnel.

#### 1.1.5 Control Handle

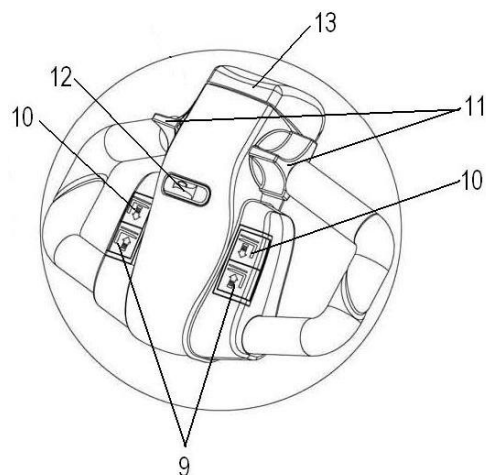

9	“Lower” button	Lowers load forks.
10	“Lift” button	Raises load forks.
11	Driving regulator	Controls the driving speed and direction
12	Warning signal button	Triggers a warning signal.
13	Collision safety switch	Safety function which, when activated, forces the truck to reverse for approx. 3 seconds and then cuts out until the controller is briefly restored to neutral.

#### 1.1.6 Emergency brake switch

The supply current is interrupted, all electrical functions are deactivated and the truck is automatically braked.

## 1.2 Identification points and data plates

Item	Description
14	AC Power Decal
15	Operator Warning Decal
16	Truck data plate
17	“Never stand under the forks” warning
18	“Never stand or ride on forks for any reason” warning
19	“DO not operate this truck unless you are trained and authorized” warning

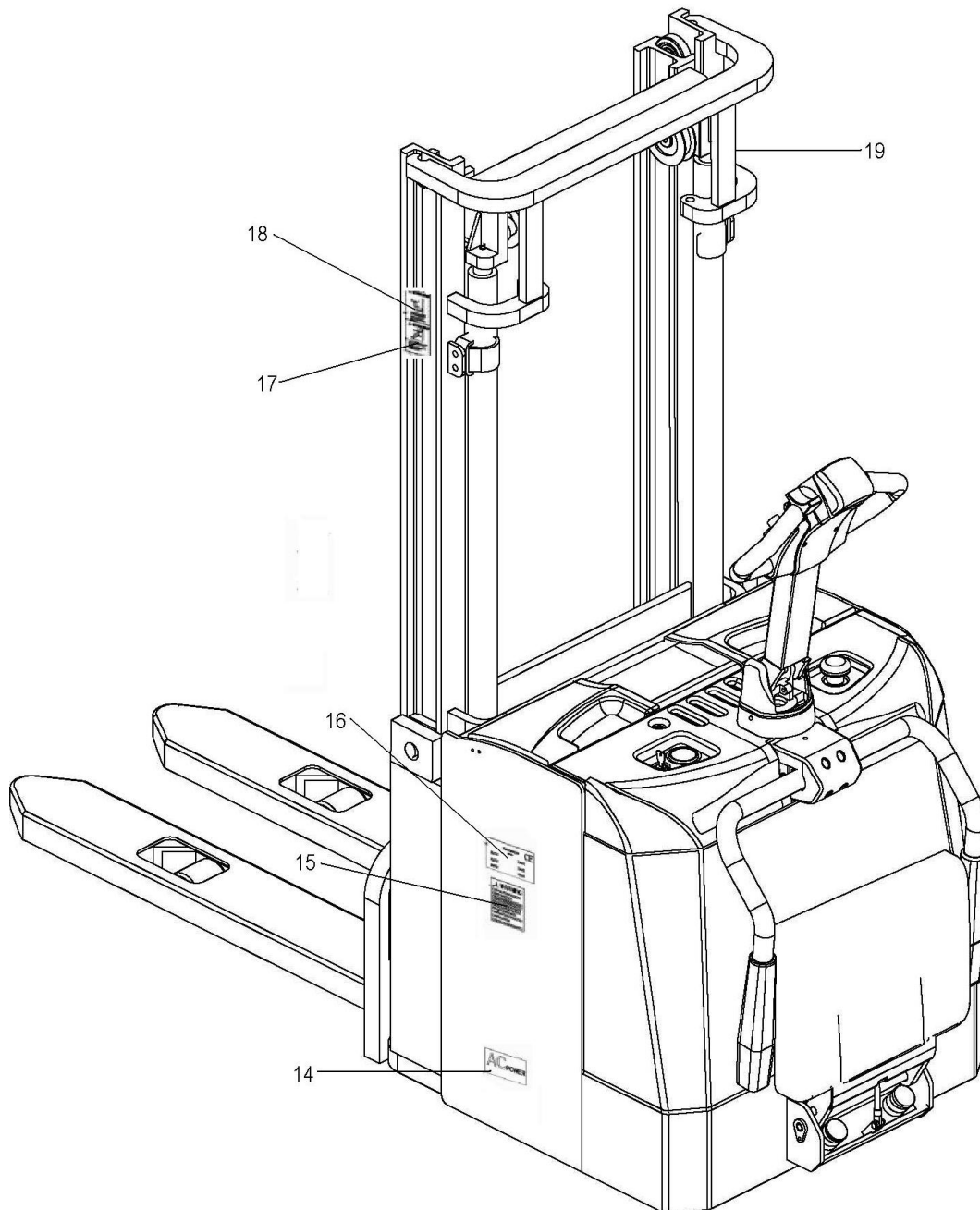

### 1.2.1 Truck data plate

⊕

## PALLET STACKER

⊕

MODEL, TYPE	I	-	VII	
SN.	V	SERVICE WEIGHT	II	kg
NOMINAL LOAD CENTER	XI	mm	RATED CAPACITY	VI
WEIGHT WITHOUT BATTERY	III	kg	MAX.ALLOWABLE BATTERY WEIGHT	VIII
NOMINAL VOLTAGE	IV	V	MIN.ALLOWABLE BATTERY WEIGHT	IX
YEAR OF MANUFACTURE	XVI	RATED CAPACITY OF TRAVELING MOTOR	XVII	kw

	MAX.LIFT HEIGHT	LOAD CENTER	CAPACITY AT MAX.L.H
WITHOUT ATTACHMENT	X mm	XI mm	XII kg
WITH ATTACHMENT	XIII mm	XIV mm	XV kg

**HANGCHA GROUP CO., LTD.**

⊕

License No.: TS2510002-2012      Add: 88 Donghuan Road, Linan, Hangzhou, China

⊕

For queries regarding the truck or ordering spare parts please quote the truck serial Number SN.

### 1.3 Specifications

Item	Description		Unit	Parameter	
1	Rated capacity		Kg	1600	
2	Load centre distance (c)		mm	600	
3	Lift (mast-dependent) (h1)	Max	mm	Remark①	
4	Raise lift speed(Max)	Fully load	mm/s	100	
5	Travel speed(Max)	Non-load	Km/h	8.0 Remark②	
6	Max. grade ability (5 min rating)	Fully load	%	8	
7	Turning radius	Pedal folded (w1)	mm	1665	
		Pedal unfold (w2)	mm	2095	
8	Ground clearance(m2)	Min	mm	30	
9	Fork thickness (S)	Max	mm	60	
10	Fork height (h8)		mm	85	
11		length	Pedal folded (L2)	mm	2003
			Pedal unfold (L1)	mm	2525
12	Dimensions	width(b1)	mm	850	
13		height (h6)	mm	Remark①	
14	Pedal height (h2)		mm	140	
15	Side arm height (h3)		mm	1000	
16	Control handle height	Max (h5)	mm	1160	
		Min (h4)	mm	1500	
17	Net weight (including battery)		Kg	1050	
20	Motor	Travel	KW	1.5	
21		Raise lift	KW	3.0	
22	Wheel	Loading Wheel /number		Φ85x70/4	
23		Driving wheel /number		Φ230x75/1	
24		Balance Wheel /number		Φ130x60/2	
25	Battery	Type		2V-VCF	
26		Voltage / capacity	V/Ah	24/210	
27	Brake distance	Non-load	mm	1	
28	Wheelbase (Y)		mm	1394	
29	Distance between forks, outer	Fork (b11)	mm	380	

Remark:

① Particular parameter see the form1-1 《parameter of Lift (mast-dependent) and height》 on page 8.

② The Travel speed(Max) is 6.0Km/h when the pedal folded or side arm folded.

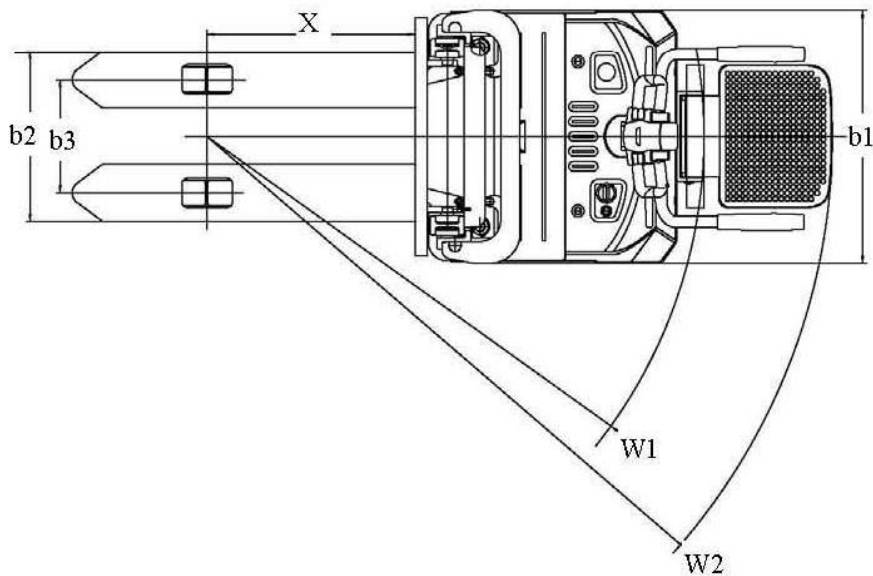
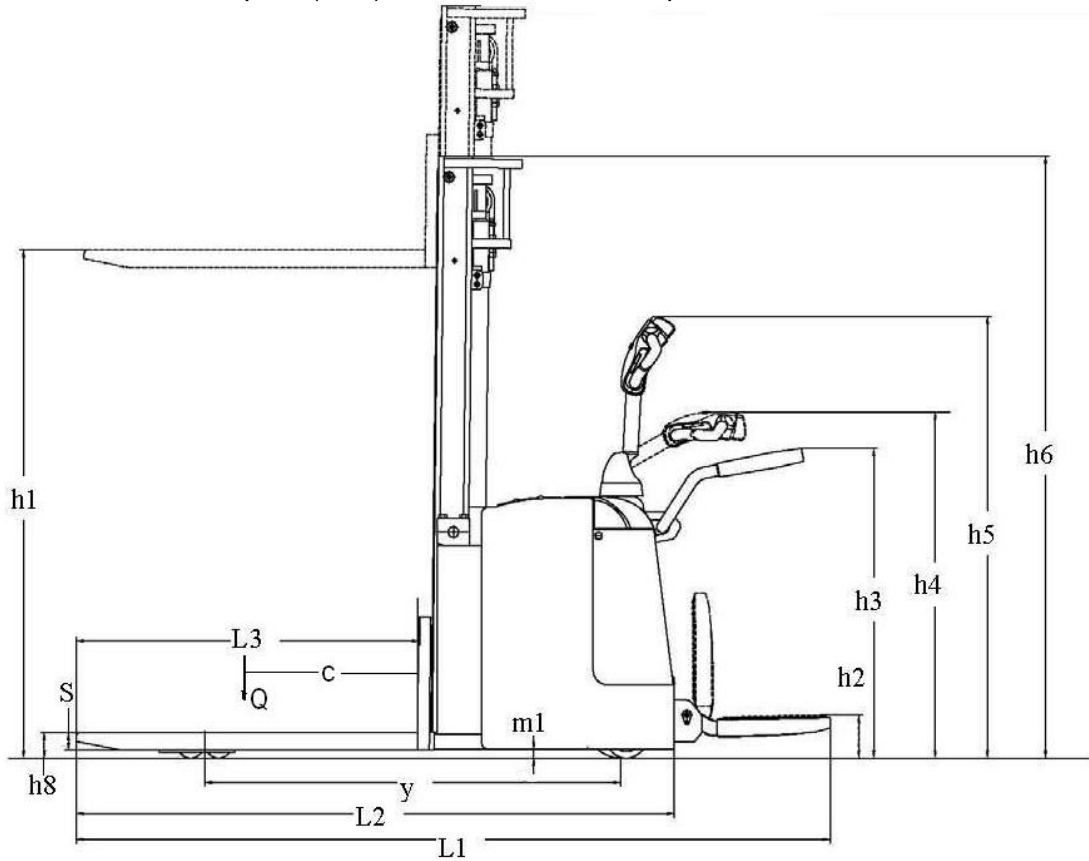

Form 1-1 parameter of Lift (mast-dependent) and height

Lift (mast-dependent)	2600	2950	3150	3450	3750	4150	4450	4950
h1 (mm)								
Height h6	1844	2019	2119	2269	2419	2619	2769	3019
(mm)								

## 2. Transport and Commissioning

### 2.1 Transport

#### 2.1.1 Lifting the truck by crane

1. Only use crane lifting gear with sufficient capacity.

2. Loading weight = net weight of truck (+ battery weight for electric trucks).

3. Crane lifting gear get across fixed hole(1) to Lifting the truck.

– Park the truck securely.(see 3.2.4 Parking the truck securely on page 14).

– Secure the crane slings to the attachment points (1).

Raise the truck with the forks at the side between the axles. Raise the truck slightly and make sure it is securely positioned on the forks. Necessary adjust or secure the forks with stops. Lower the truck slowly onto the ground and prevent it from rolling away.

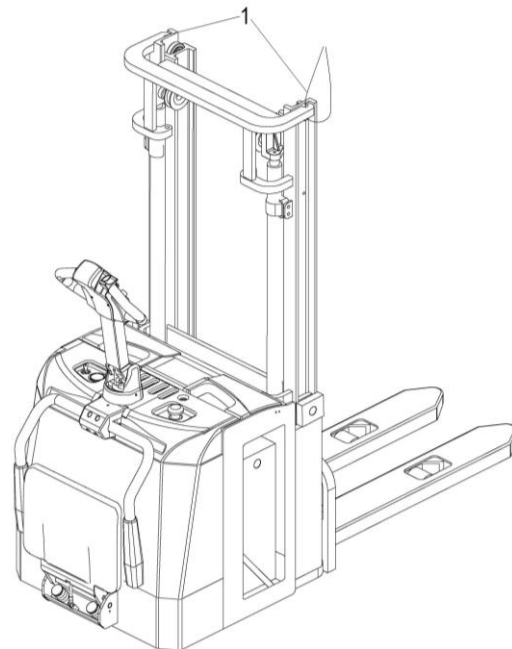

#### 2.1.2 Securing the truck during transport

The truck must be securely fastened when transported on a lorry or a trailer.

Keep pedal and side arm folded, avoid them out of bodywork.

- The rope is used to fix the truck must be firm enough.

- Check .

Both sides need to fix.

Loading must be carried out by staff specially trained. In each case correct measurements shall be determined and appropriate safety measures adopted.

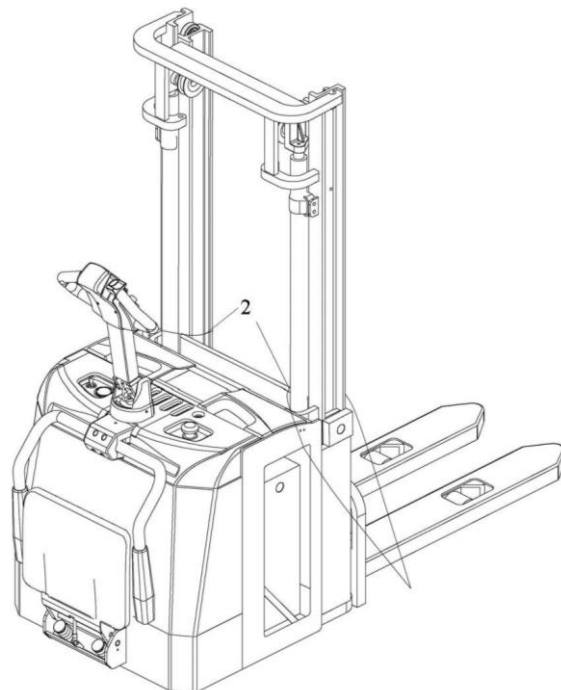

### 2.2 Using the Truck for the First Time

Only operate the truck with battery current. Rectified AC current will damage the electronic components. Cable connections to the battery (tow leads) must be less than 6 m .

Preparing the truck for operation after delivery or transport

#### Procedure

- Check the equipment is complete.
- Check the hydraulic oil level.
- Install the battery if necessary, (see "4.4 Battery removal and installation" on page 19).
- Charge the battery, (see "4.3 Charging the battery" on page 18).

#### **2.3 During brake-in**

We recommended operating the machine under light load conditions for the first stage of operation to get the most from it. Especially the requirements given below should be observed while the machine is in a stage of 100 hours of operation.

1. Must prevent the new battery from over discharging when early used.
2. Perform specified preventive maintenance services carefully and completely.
3. Avoid sudden stop, starts or turns.
4. Oil changes and lubrication are recommended to do earlier than specified.
5. Limited load is 70~80% of the rated load.

## 3.Operation

### 3.1 Safety Regulations for the Operation of Forklift Trucks

**Driver authorisation:** The forklift truck may only be used by suitably trained personnel, who have demonstrated to the proprietor or his representative that they can drive and handle loads and have been authorised to operate the truck by the proprietor or his representative.

**Driver's rights, obligations and responsibilities:** The driver must be informed of his duties and responsibilities and be instructed in the operation of the truck and shall be familiar with the operator manual. The driver shall be afforded all due rights. Safety shoes must be worn with pedestrian operated trucks.

**Unauthorised Use of Truck:** The driver is responsible for the truck during the time it is in use. He shall prevent unauthorised persons from driving or operating the truck. It is forbidden to carry passengers or lift personnel.

**Damage and Faults:** The supervisor must be immediately informed of any damage or faults to the forklift truck. Trucks not safe for operation (e.g. wheel or brake problems) must not be used until they have been rectified.

**Repairs:** The driver must not carry out any repairs or alterations to the forklift truck without the necessary training and authorisation to do so. The driver must never disable or adjust safety mechanisms or switches.

**Hazardous area:** A hazardous area is defined as the area in which a person is at risk due to truck movement, lifting operations, the load handler (e.g. forks or attachments) or the load itself. This also includes areas which can be reached by falling loads or lowering operating equipment.

Unauthorised persons must be kept away from the hazardous area. Where there is danger to personnel, a warning must be sounded with sufficient notice. If unauthorised personnel are still within the hazardous area the truck shall be brought to a halt immediately.

**Safety Devices and Warning Signs:** Safety devices, warning signs and warning instructions shall be strictly observed.

### 3.2 Starting up the truck

#### 3.2.1 Preparing

Before the truck can be commissioned, operated or a load unit lifted, the driver must ensure that there is nobody within the hazardous area.



### Checks and operations to be performed before starting daily work

- Visually inspect the entire truck (in particular wheels and load handler) for obvious damage.
- Visually inspect the battery attachment and cable connections.

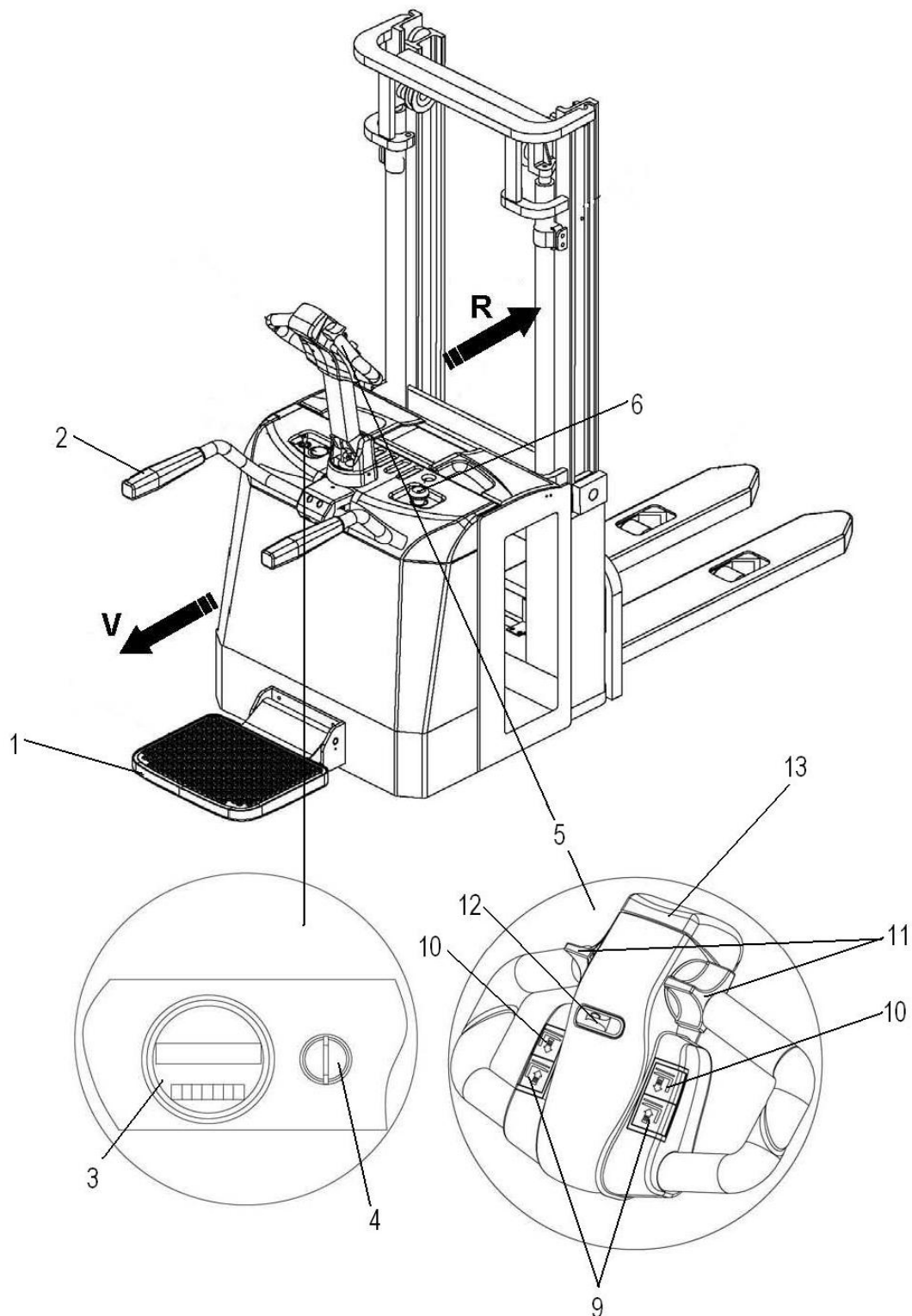

### 3.2.2 Switching on the truck

- Make sure the Emergency brake switch is depressed(6).

- Make sure the battery is connected
- Insert the key in the key switch ( 4 ) and turn it to the right as far as it will go.
- Test the warning signal switch (6).

The truck is now operational.

The battery charge / discharge indicator (3) shows the available battery capacity.

Test the braking operation of the control handle (5).

**Warning!**  
Before operating the truck, check all controls and warning devices for proper operation. If any damage or fault is found, don't operate truck until corrected.

### 3.2.3 Travelling, Steering, Braking

Never carry passengers.

Be extremely careful when driving and steering, especially when operating outside the geometry of the truck.

#### Emergency Disconnect

- Drawing back the emergency brake switch (6).

All electrical functions are deactivated.

#### Emergency Stop

Automatic braking (emergency stop) occurs when the control handle (5) is released—the tiller automatically reverts to the upper brake zone (B).

If the control handle moves slowly to the braking zone, the cause of this fault must be rectified. If necessary, replace the recuperating spring.

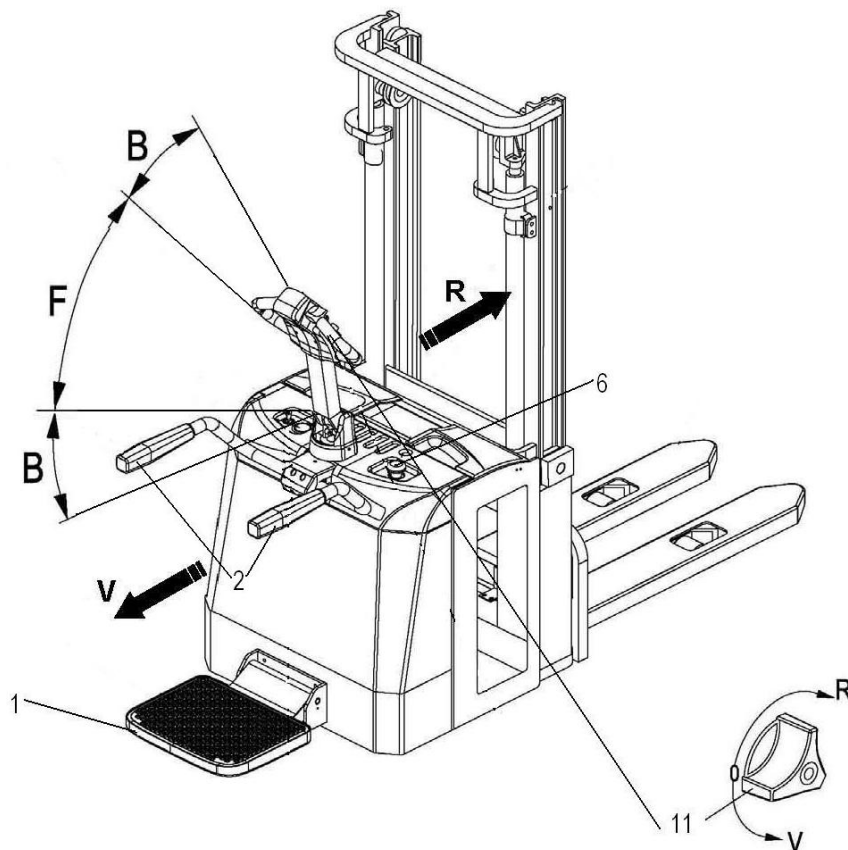

## **Travel**

Do not reach between the operator pedal and the truck panel when you fold up the pedal.

We distinguish between two travel modes:

Truck with a folding operator pedal and moving handle.

– Pedestrian mode: Push the side arms in, fold up the operator pedal (1). The truck can only be operated at the reduced travel speed.

– Rider mode: Push the side arms out, fold down the operator pedal (1). The truck can be operated at maximum speed.

### **General:**

– Set the handle (5) to the travel zone (F).

– Turn the controller (11) to the required direction (fwd. or rev.).

If the side arms are not folded out, the truck can only be operated at reduced speed.

Do not drive the truck unless the panels are closed and properly locked. When travelling through swing doors etc. make sure that the doors do not activate the collision safety button (13).

### **Travelling on inclines**

Loads must always be carried at that end of the truck facing uphill.

### **Steering**

In narrow bends the driver extends beyond the geometry of the truck.

– Move the tiller (5) to the left or right.

### **Braking**

The brake pattern of the truck depends largely on the ground conditions. The driver must take this into account when operating the truck.

The truck can brake in three different ways:

– by plugging

– by using the operating brake

– with the emergency brake switch (Emergency Disconnect)

### **By Plugging:**

– When travelling, set the controller (11) to the opposite direction.

The truck brakes regeneratively until it starts to move in the opposite direction.

The rate of braking depends on the position of the controller.

### **Braking with the operating brake:**

– Set the tiller (5) to one of the brake zones (B).

The drive motor brakes regenerative ( motor brake ) . Only when this brake fails to achieve the necessary brake force is the mechanical brake ( magnetic brake) applied.

When the truck is idle the magnetic brake (magnetic brake) applies.

When the tiller is released it reverts to the upper braking zone (B).

### **Braking with the emergency brake switch:**

– Press Emergency brake switch (11) .

The circuit is interrupted , all electrical functions are cut out and the truck automatically brakes (magnetic brake).

## **3.2.4 Parking the truck securely**

When you leave the truck it must be securely parked even if you only intend to leave it

for a short time.

- Do not park the truck on an incline.
- Fully lower the load forks.
- Set the key switch (10) to the "0" position and remove the key.
- Drawing back the emergency brake switch (11).
- Fold in the folding side arm

Do not reach between the operator platform and the truck panel when you fold up the folding platform.

### **3.3 Safety regulations for truck operation**

**Travel routes and work areas :** Only use lanes and routes specifically designated for truck traffic. Unauthorised persons must stay away from work areas . Loads must only be stored in places specially designated for this purpose.

**Driving conduct:** The driver must adapt the travel speed to local conditions . The truck must be driven at slow speed when negotiating bends or narrow passageways ,when passing through swing doors and at blind spots . The driver must always observe an adequate braking distance between the forklift truck and the vehicle in front and must be in control of the truck at all times . Abrupt stopping (except emergencies) , rapid U turns and overtaking at dangerous or blind spots are not permitted. It is forbidden to lean out of or reach beyond the working and operating area.

**Travel visibility :** The driver must look in the direction of travel and must always have a clear view of the route ahead . Loads which affect visibility must be stored at the rear of the truck.If this is not possible , a second person must walk in front of the truck as a lookout.

**Negotiating slopes and inclines :** Negotiating slopes or inclines is only permitted if such roads are clean and have a non-slip surface and providing such journeys are safely undertaken in accordance with the technical specifications for the truck in question. The truck must always be driven with the load unit facing uphill. The industrial truck must not be turned , operated at an angle or parked on inclines or slopes. Inclines must only be negotiated at slow speed, with the driver ready to brake at any moment.

**Negotiating lifts and docks :** Lifts and docks must only be used if they have sufficient capacity, are suitable for driving on and authorised for truck traffic by the owner . The driver must satisfy himself of the above before entering these areas . The truck must enter lifts with the load in front and must take up a position which does not allow it to come into contact with the walls of the lift shaft.

Persons riding in the lift with the forklift truck must only enter the lift after the truck has come to a rest and must leave the lift before the truck.

### **3.4 Collecting and depositing loads**

Before picking up a load , the driver must ensure that it is correctly palletised and that the capacity of the truck is not exceeded. It is forbidden to collect long loads at an angle.

– Fully insert the truck and the load handler underneath the load unit.

#### **Lift**

– Press the “Lift” (10) button until you reach the desired lift height.

Release the button as soon as you reach the limit position of the load handler.

#### **Lower**

– Press the “Lower ” button (9) until you reach the required lifting height.

Do not deposit the load in a sudden manner.

**Nature of loads to be carried:** The operator must make sure that the load is in a satisfactory condition. Only carry loads that are positioned safely and carefully . Use suitable precautions, e.g. a load guard , to prevent parts of the load from tipping or falling down.

## 4. Battery Maintenance & Charging

### 4.1 Safety regulations for handling acid batteries

Park the truck securely before carrying out any work on the batteries.

**Maintenance personnel :** Batteries may only be charged, serviced or replaced by trained personnel. The present operator manual and the manufacturer's instructions concerning batteries and charging stations must be observed when carrying out the work.

#### Fire protection :

- Smoking and naked flames must be avoided when working with batteries.
- Wherever a truck is parked for charging there shall be no inflammable material or operating fluids capable of creating sparks within 2 metres around the truck.
- The area must be well ventilated.
- Fire protection equipment must be provided.



#### Protection against electric shock:

- Battery has high voltage and energy.
- Do not bring short circuit.
- Do not approach tools to the two poles of the battery, which can cause the sparkle.

#### Do not overuse battery:

- If you use up the energy of battery till the forklift immovability, you will shorten its working hours.
- Shower for battery appears need for charge, please charge it quickly.

#### Inspection for electrolyte:

- Do not using forklift which is absent electrolyte.
- Inspection for electrolyte level every week.
- When electrolyte level is low, you must add distilled water to the level appointed.

**Battery maintenance:** The battery cell covers must be kept dry and clean. The terminals and cable shoes must be clean, secure and have a light coating of dielectric grease. Batteries with non insulated terminals must be covered with a non slip insulation mat.

#### Warning!

1. Do not use dry cloth or fibre cloth to clean the battery, avoiding static to bring the explosion.
2. Unfixing battery plug.
3. Cleaning with wet cloth.
4. Wearing glasses for protecting eyes rubber overshoes and rubber glove.

**Battery Disposal:**Batteries may only be disposed of in accordance with national environmental protection regulations or disposal laws.The manufacturer’s disposal instructions must be followed.

Before closing the battery cover make sure that the battery lead cannot be damaged.

Batteries contain an acid solution which is poisonous and corrosive . Therefore , always wear protective clothing and eye protection when carrying out work on batteries . Above all avoid any contact with battery acid.

Nevertheless, should clothing, skin or eyes come in contact with acid the affected parts should be rinsed with plenty of clean water-where the skin or eyes are affected call a doctor immediately. Immediately neutralise any spilled battery acid.

Only batteries with a sealed battery container may be used.

The weight and dimensions of the battery have considerable affect on the operational safety of the truck. Battery equipment may only be replaced with the agreement of the manufacturer.

## 4.2 Battery type & dimension

Battery type & dimension as follow :

Tuck type	Battery type	Battery height (mm)	Battery length (mm)	Battery width (mm)
CDD14-ES	24V-VCF	600	815	222

When replacing or installing batteries, ensure that the battery is correctly secured in the battery compartment of the truck.

## 4.3Charging the battery

### 4.3.1Exposing the battery

Park the truck securely (See 3.2.4 Parking the truck securely Page 14).

- Drawing back the emergency brake switch (3).
- Lift up the battery panel (2) using the grip mould (1) and fold it back.

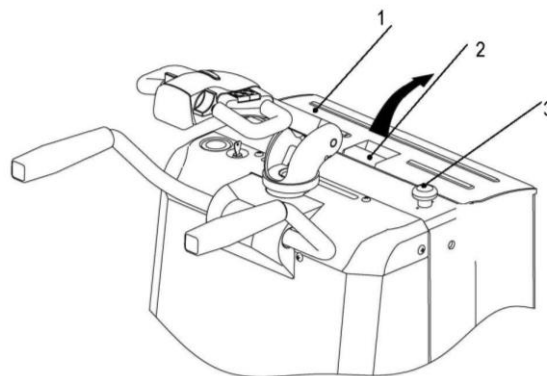

### 4.3.2Charging the battery

#### Safety regulations for Charging the battery

- To charge the battery, the truck must be parked in a closed and properly ventilated room.
- When charging, the tops of the battery cells must be exposed to provide sufficient ventilation.
- Do not place any metal objects on the battery .
- Before charging, check all cables and plug connections for visible signs of damage.
- It is essential to follow the safety regulations of the battery and charging station manufacturers.

### Charging step

- Check whether the condition is according with "Safety regulations for Charging the battery".
- Park the truck securely(See 3.2.4 Parking the truck securely Page 14 ).
- Expose the battery ( see 4.3.1 Exposing the battery Page 18 ).
- Remove the battery connector (29).
- Connect the battery plug (30) with the charging lead of the stationary charger (29) and turn on the charger.

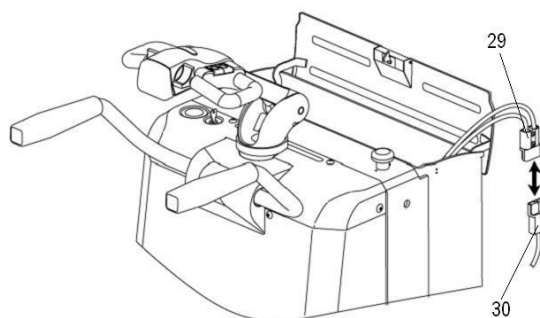

## 4.4 Battery removal and installation

### 4.4.1 Changing the battery

- (1) Undo the spring elements of the battery panel and remove the battery panel.

The truck must be parked on level ground. To prevent short circuits, batteries with exposed terminals or connectors must be covered with a rubber mat. Place the battery connector or the battery cable in such a way that they will not get caught on the truck when the battery is removed.

When transporting batteries using a crane, ensure that the crane is of adequate Capacity (the battery weight is indicated on the battery data plate on the battery container). The lifting gear must exert a vertical pull so that the battery container is not compressed. The hooks must be attached to the eyes (4) of the battery in such a way that they cannot fall onto the battery cells when the lifting gear is discharged.

- Park the truck securely(See 3.2.4 Parking the truck securely Page 14 ).
- Expose the battery ( see 4.3.1 Exposing the battery Page 18 ).
- Remove the battery connector (3).

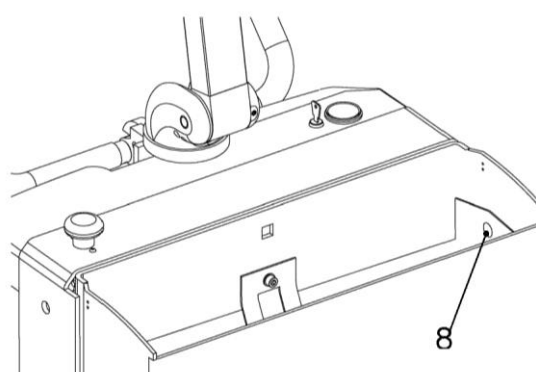



- Strap the crane lifting gear to the eyes (8).
- Drawing back the emergency brake switch.

When replacing a battery always use the same battery type. Extra weights must not be removed and must remain in the same position.

- Installation is in the reverse order of operations. When reinstalling the battery, heed the required installation position and make sure the battery is connected correctly.

(2) remove the side panel

The truck must be parked on level ground. To prevent short circuits, batteries with exposed terminals or connectors must be covered with a rubber mat. Place the battery connector or the battery cable in such a way that they will not get caught on the truck when the battery is removed.

-Remove the battery panel which on the side, then pull out the battery. Installation is in the reverse order of operations.

After installing the battery again, check all cables and plug connections for visible signs of damage.

Before starting the truck, the battery panel must be firmly closed. Close the battery panel carefully and slowly. Do not reach between the battery panel and the chassis.

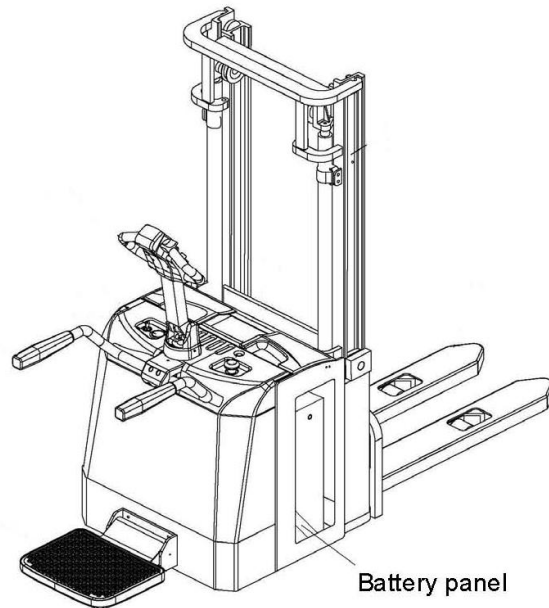

## **5.Forklift Truck Maintenance**

### **5.1Operational safety and environmental protection**

- The servicing and inspection operations contained in this chapter must be performed in accordance with the intervals indicated in the servicing checklists.
- Any modification to the forklift truck assemblies, in particular the safety mechanisms, is prohibited. The operational speeds of the truck must not be changed under any circumstances.
- Only original spare parts have been certified by our quality assurance department. To ensure safe and reliable operation of the forklift truck, use only the manufacturer's spare parts. Used parts, oils and fuels must be disposed of in accordance with the relevant environmental protection regulations. For oil changes, contact the manufacturer's specialist department.
- Upon completion of inspection and servicing, carry out the activities listed in the "Recommissioning (on page 27)" section.

### **5.2Maintenance Safety Regulations**

#### **Maintenance personnel**

Industrial trucks must only be serviced and maintained by the manufacturer's trained personnel.

The manufacturer's service department has field technicians specially trained for these tasks. We therefore recommend a maintenance contract with the manufacturer's local service centre.

#### **Lifting and jacking up**

When an industrial truck is to be lifted, the lifting gear must only be secured to the points specially provided for this purpose.

When jacking up the truck, take appropriate measures to prevent the truck from slipping or tipping over (e.g. wedges, wooden blocks).

You may only work underneath a raised load handler if it is supported by a sufficiently strong chain.

#### **Cleaning**

Do not use flammable liquids to clean the industrial truck.

Prior to cleaning, all safety measures required to prevent sparking (e.g. through short circuits) must be taken. For battery-operated trucks, the battery connector must be removed.

Only weak suction or compressed air and non-conductive antistatic brushes may be used for cleaning electric or electronic assemblies.

If the truck is to be cleaned with a water jet or a high-pressure cleaner, all electrical and electronic components must be carefully covered beforehand as moisture can

cause malfunctions.

Do not clean with pressurised water.

After cleaning the truck, carry out the activities detailed in the “ Recommission (on page 27)” section.

### **Electrical System**

Only suitably trained personnel may operate on the truck’s electrical system.

Before working on the electrical system, take all precautionary measures to avoid – electric shocks.

For battery-operated trucks, also de-energise the truck by removing the battery connector.

### **Welding**

To avoid damaging electric or electronic components, remove these from the truck before performing welding operations.

### **Settings**

When repairing or replacing hydraulic, electric or electronic components or assemblies, always note the truck-specific settings.

### **Tyres**

The quality of tyres affects the stability and performance of the truck. When replacing factory fitted tyres only use original manufacturer’s spare parts, as otherwise the data plate specifications will not be kept.

When changing wheels and tyres, ensure that the truck does not slew (e.g. when replacing wheels always left and right simultaneously).

### **Lift chains**

Lift chains wear rapidly if not lubricated.

The intervals stated in the service checklist apply to normal duty use. More demanding conditions (dust, temperature) require more regular lubrication.

The prescribed chain spray must be used in accordance with the instructions.

Applying grease externally will not provide sufficient lubrication.

### **Hydraulic hoses**

The hoses must be replaced every six years. When replacing hydraulic components, also replace the hoses in the hydraulic system.

## **5.3 Servicing and inspection**

Thorough and expert servicing is one of the most important requirements for the safe operation of the industrial truck. Failure to perform regular servicing can lead to truck failure and poses a potential hazard to personnel and equipment.

The service intervals stated are based on single shift operation under normal operating conditions. They must be reduced accordingly if the truck is to be used in conditions of extreme dust, temperature fluctuations or multiple shifts.

The following maintenance checklist states the tasks and intervals after which they should be carried out. Maintenance intervals are defined as:

W = Every 50 service hours, at least weekly

A = Every 500 operating hours

B = Every 1000 operating hours, or at least annually

C = Every 2000 operating hours, or at least annually

W service intervals are to be performed by the customer.

In the run-in period - after approx. 100 service hours - or after repair work, the owner must check the wheel nuts/bolts and re-tighten if necessary.

### 5.3.1 Maintenance Checklist

		Standard = ★ Cold Store = ☆	W	A	B	C
Brake	1.1	Check magnetic brake air gap.			★	
Electrics	2.1	Test instruments, displays and control switches.			★	
	2.2	Test warning and safety device.	☆		★	
	2.3	Check fuse ratings.				★
	2.4	Make sure wire connections are secure and check for damage.			★	
	2.5	Test micro switch setting.			★	
	2.6	Check contactors and relays.			★	
	2.7	Frame leakage test			★	
	2.8	Test cable and motor attachments.			★	
	2.9	Check carbon brush wear, replace if necessary.			★	
Power supply	3.1	Visually inspect battery	☆		★	
	3.2	Check battery cable connections are secure, grease terminals if necessary.	☆		★	
	3.3	Check acid density, acid level and battery voltage.	☆		★	
Travel	4.1	Check motor suspension.			★	
	4.2	Check the transmission for noise and leakage.			★	
	4.3	Replace gear oil if service life exceeded (10,000 hours).				
	4.4	Check travel mechanism, adjust and lubricate if necessary. Check tiller recuperating function.	☆		★	
	4.5	Check wheels for wear and damage.	☆		★	
	4.6	Check wheel bearings and attachments.			★	
Truck design	5.1	Test the operator's platform and check for damage.			★	
	5.2	Check chassis for damage and screw connections.			★	
	5.3	Check labels.			★	

			Standard = ★				
			Cold Store = ☆	W	A	B	C
Hydraulic operation	6.1	Check operation, wear and setting.				★	
	6.2	Check forks for wear and damage.				★	
	6.3	Test hydraulic system.	☆			★	
	6.4	Check that hose and pipe lines and their connections are secure, check for leaks and damage.	☆			★	
	6.5	Check cylinders and piston rods for damage and leaks, and make sure they are secure.	☆			★	
	6.6	Check hydraulic oil level.	☆			★	
	6.7	Replace hydraulic oil filter.				☆	★
	6.8	Replace hydraulic oil.				☆	★
	6.9	Check wheels for wear and damage.				★	
Agreed performance levels	7.1	Lubricate truck in accordance with Lubrication Schedule.	☆			★	
	7.2	Test run				★	
	7.3	Demonstration after servicing				★	

### 5.3.2 Lubrication Schedule

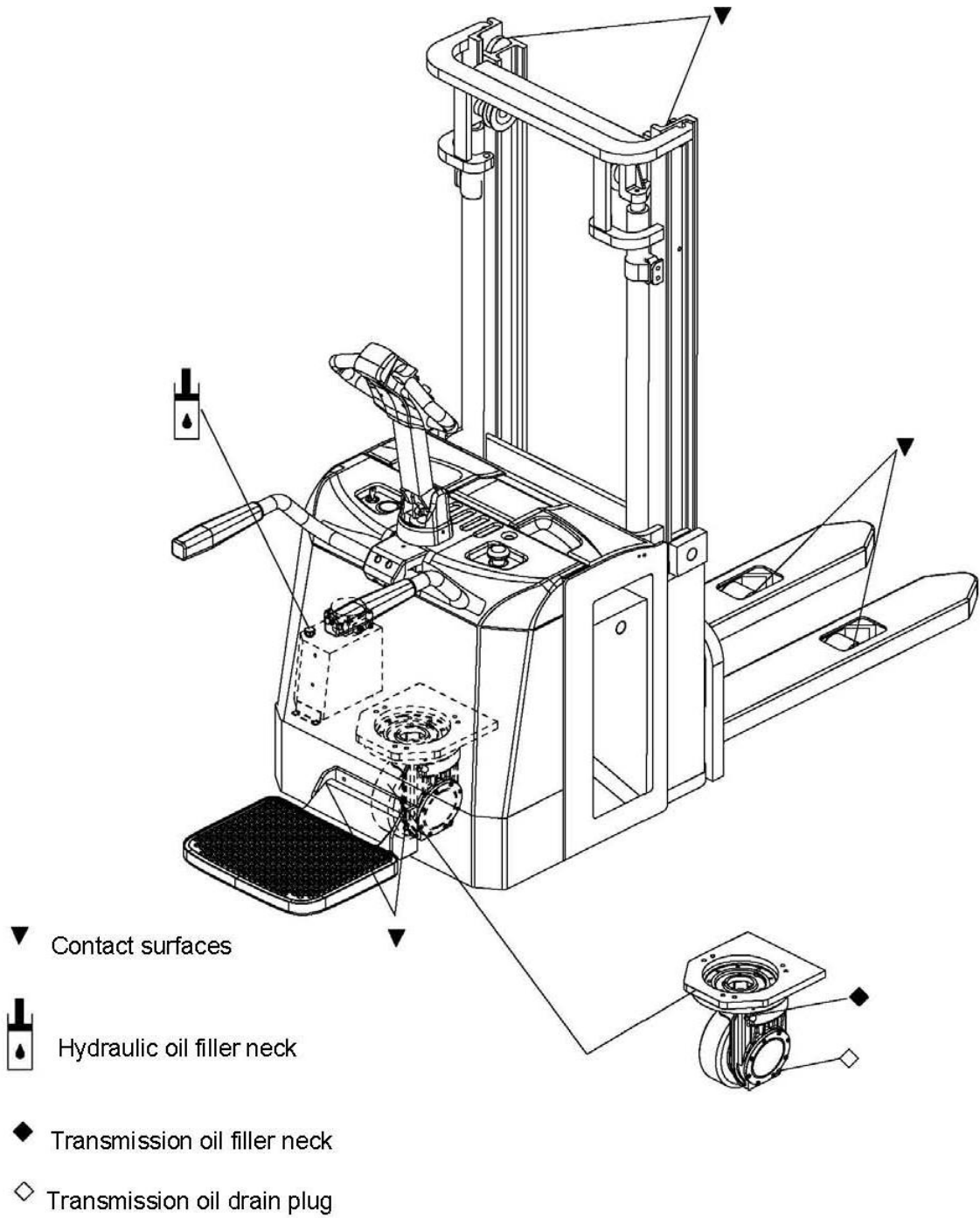

## Fuels, coolants and lubricants

**Handling consumables:** Consumables must always be handled correctly. Follow the manufacturer's instructions.

Improper handling is hazardous to health, life and the environment. Consumables must only be stored in appropriate containers. They may be flammable and must therefore not come into contact with hot components or naked flames.

Only use clean containers when filling up with consumables. Do not mix consumables of different grades. The only exception to this is when mixing is expressly stipulated in the Operating Instructions.

Avoid spillage. Spilled liquids must be removed immediately with suitable bonding agents and the bonding agent/consumable mixture must be disposed of in accordance with regulations.

Code	Description	Used for
A	HM46#	Hydraulic system
B	Grease, Polyube GA352P	Lubrication
C	GL-85W-90	Transmission

### 5.3.3 Maintenance Instructions

#### Prepare the truck for maintenance and repairs

All necessary safety measures must be taken to avoid accidents when carrying out maintenance and repairs. The following preparations must be made:

- Park the truck securely (See 3.2.4 Parking the truck securely Page 14 ).
- Disconnect the battery to prevent the truck from accidentally starting.
- When working under a raised lift truck, secure it to prevent it from tipping or sliding away.

( see 4.3.1 Exposing the battery Page 18 )

#### Removing the front panel

- Open the battery panel( see 4.3.1 Exposing the battery Page 18 ).
- Remove the two screws (1).
- Carefully lift off the front panel (2).

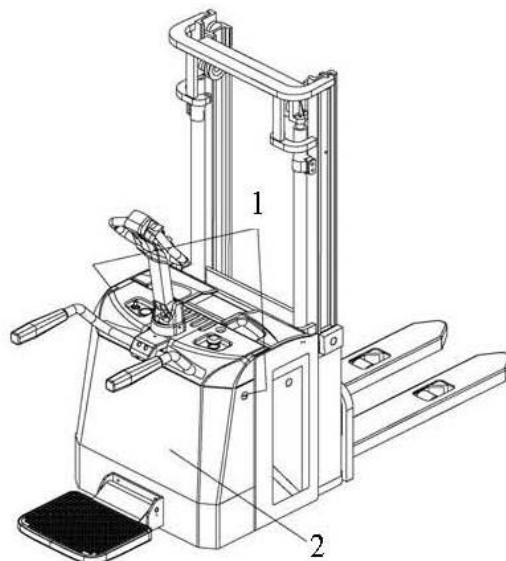

#### Replacing the drive wheel

The drive wheel must only be replaced by authorised service personnel.

### Checking the hydraulic oil level

- Prepare the truck for maintenance and repairs ( See 5.3.3 Maintenance Instructions Page26 ).
- Opening the front panel(See 5.3.3 Maintenance Instructions Page26).
- Check hydraulic oil level in hydraulic reservoir .

There is oil level display on the level gauge  
The Oil level depends on the lift height.  
The oil level must be checked when the load forks are lowered.

- If necessary add hydraulic oil of the correct grade ( See 5.3.2 Lubrication Schedule P26 ) .

Installation is the reverse order.

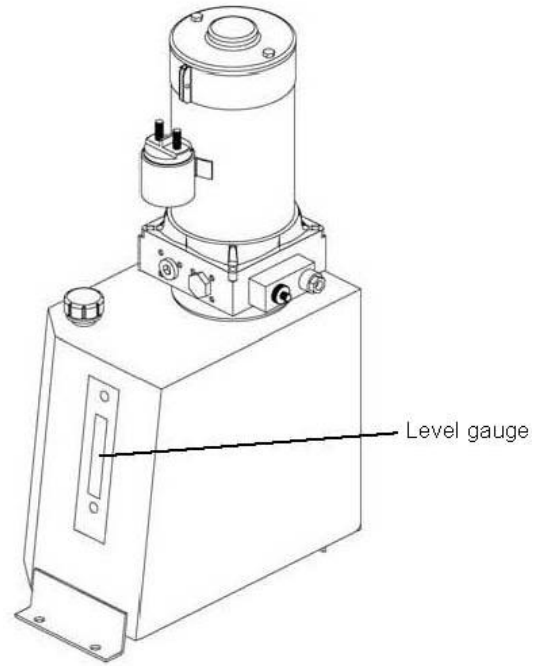

### Check transmission oil level

- Prepare the truck for maintenance and repairs (See 5.3.3 Maintenance Instructions Page26 ).
- Remove the front panel (See 5.3.3 Maintenance Instructions Page26).
- Turn the tiller to the right stop.
- Check the transmission oil level, it should be at the control plug level (See 5.3.2 Lubrication Schedule Page26).
- If necessary add transmission oil of the correct grade (See 5.3.2 Lubrication Schedule Page26).

Installation is the reverse order.

### Checking electrical fuses

- Prepare the truck for maintenance and repairs (See 5.3.3 Maintenance Instructions Page26 ).
- Dismantle the front panel (See 5.3.3 Maintenance Instructions Page26).
- Check rating of all fuses in accordance with table, replace if necessary.

Item	To protect:	Rating
1	Traction / Lift motor	200A
2	Controller	15A

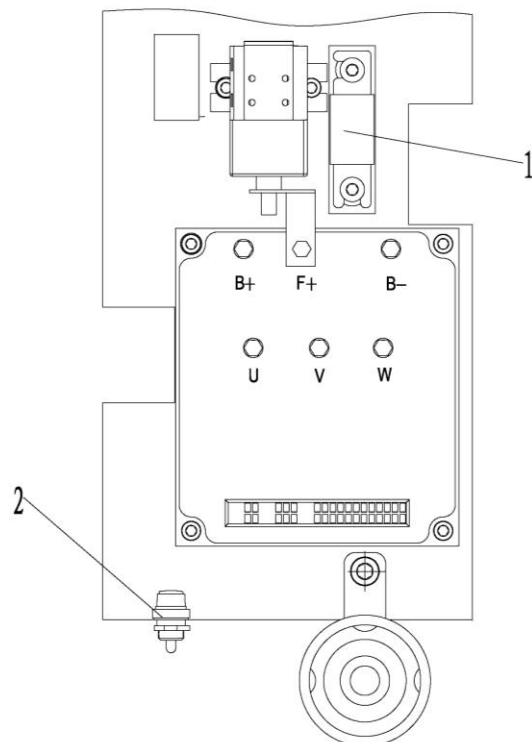

### Recommissioning

The truck may only be recommissioned after cleaning or repair work, once the following operations have been performed.



- Test horn.
- Test Emergency brake switch.
- Test brake.
- Lubricate the truck in accordance with the maintenance schedule.

## **5.4Decommissioning the industrial truck**

If the industrial truck is to be decommissioned for more than two months , e.g. foroperational reasons,it must be parked in a frost-free and dry location and allnecessary measures must be taken before, during and after decommissioning as described.

On decommissioning the truck must be jacked up so that all the wheels are clear of the ground. This is the only way of ensuring that the wheels and wheel bearings are not damaged.

If the truck is to be out of service for more than 6 months , further measures must be taken in consultation with the manufacturer’s service department.

### **5.4.1Prior to decommissioning**

- Thoroughly clean the truck.
- Check the brakes.
- Check the hydraulic oil level and replenish as necessary (See 5.3.3 Maintenance Instructions Page26 ).
- Apply a thin layer of oil or grease to any non-painted mechanical components.
- Lubricate the truck in accordance with the maintenance schedule (See 5.3.2 Lubrication Schedule P26 ).
- Charge the battery (See 4.3Charging the battery P18).
- Disconnect the battery, clean it and apply grease to the terminals.  
In addition, follow the battery manufacturer’s instructions.
- Spay all exposed electrical contacts with a suitable contact spray.

### **5.4.2During decommissioning**

Every 2 months:

- Charge the battery (See 4.3Charging the battery P18).

Battery powered trucks:

The battery must be charged at regular intervals to avoid depletion of the battery through self-discharge. The sulfatisation would destroy the battery.

### **5.4.3 Restoring the truck to operation after decommissioning**

- Thoroughly clean the truck.
- Lubricate the truck in accordance with the maintenance schedule (See 5.3.2 Lubrication Schedule P26 ).
- Clean the battery, grease the terminals and connect the battery.
- Charge the battery (See 4.3Charging the battery P18).

- Check transmission oil for condensed water and replace if necessary.
- Check hydraulic oil for condensed water and replace if necessary.
- Start up the truck (see 3.23.2 Starting up the truck P11).

Battery powered trucks:

If there are switching problems in the electrical system, apply contact spray to the exposed contacts and remove any oxide layers on the contacts of the operating controls by applying them repeatedly.

Perform several brake tests immediately after re-commissioning the truck.

### **5.5 Safety checks to be performed at regular intervals and following any unusual incidents**

Carry out a safety check in accordance with national regulations. HANGCHA has a special safety department with trained personnel to carry out such checks. The truck must be inspected at least annually (refer to national regulations) or after any unusual event by a qualified inspector. The inspector shall assess the condition of the truck from purely a safety viewpoint, without regard to operational or economic circumstances. The inspector shall be sufficiently instructed and experienced to be able to assess the condition of the truck and the effectiveness of the safety mechanisms based on the technical regulations and principles governing the inspection of forklift trucks.

A thorough test of the truck must be undertaken with regard to its technical condition from a safety aspect. The truck must also be examined for damage caused by possible improper use. A test report shall be provided. The test results must be kept for at least the next 2 inspections.

The owner is responsible for ensuring that faults are immediately rectified.

A test plate is attached to the truck as proof that it has passed the safety inspection. This plate indicates the due date for the next inspection.

### **5.6 Final de-commissioning, disposal**

Final, proper decommissioning or disposal of the truck must be performed in accordance with the regulations of the country of application. In particular, regulations governing the disposal of batteries, fuels and electronic and electrical systems must be observed.

## 6.Troubleshooting

This chapter is designed to help the user identify and rectify basic faults or the results of incorrect operation. When locating a fault, proceed in the order shown in the table.

Fault	Possible cause	Action
Truck does not start.	<ul style="list-style-type: none"><li>– Battery connector not connected</li><li>– Key switch in “0” position</li><li>– Battery charge too low</li><li>– Faulty fuse</li><li>– Truck in charge mode</li></ul>	<ul style="list-style-type: none"><li>– Check the battery connector and connect if necessary.</li><li>– Set key switch to “I”</li><li>– Check battery charge, charge battery if Necessary</li><li>– Test fuses</li><li>– Interrupt charging</li></ul>
Load can not be lifted	<ul style="list-style-type: none"><li>– Charge capacity below 20 / 40% – Hydraulic oil level too low</li><li>– Excessive load</li></ul>	<ul style="list-style-type: none"><li>– Charging the battery</li><li>– Check the hydraulic oil level</li><li>– Note maximum capacity (see data plate)</li></ul>

If the fault cannot be rectified after carrying out the remedial procedure, notify the manufacturer ' s service department ,as any further troubleshooting can only be performed by specially trained and qualified service personnel.