

THE BIG EASY



FERRARI

HEAVY DUTY FORK LIFT TRUCKS

FH

S E R I E S

CVS FERRARI Heavy Duty Fork Lift Trucks have it all.

Our new range is simply the most technically advanced product on the market. Our design team have delivered industry leading service life by incorporating the finest components into a machine with exceptional functionality. Their latest generation hydraulics, superior quality electrics, and their unique safety devices makes them the most modern and advanced trucks on the market. We have invested in driver comfort through our luxurious, comfortable cab. Smooth and slick to drive, this range is beyond comparison - they always deliver no matter what the job or environment because they are SIMPLY THE BEST.



THE RANGE

MODEL	CAPACITY	LOAD CENTRE
FH18	18 Ton	1.200 mm
FH20	20 Ton	1.200 mm
FH25	25 Ton	1.200 mm
FH28	28 Ton	1.200 mm
FH32	32 Ton	1.200 mm
FH33	33 Ton	1.200 mm
FH37	37 Ton	1.200 mm
FH42	42 Ton	1.200 mm
FH45	45 Ton	1.200 mm
FH48	48 Ton	1.200 mm

SIMPLY
THE
BEST





CHAMPIONS OF PRODUCTIVITY

With its new FH range, CVS FERRARI brings the Heavy Duty Forklift concept to unrivalled standards of productivity. Productivity is simply about the volume of work performed over time. CVS FERRARI BIG TRUCKS excel because they offer exceptional manoeuvrability, smooth and responsive operation and superior lifting speeds. Combine this with brilliant operator visibility and the feeling that the truck is glued to the ground due to our famous truck stability. That is simply why they produce more value for our customers than any other comparable machine. That is why they are true productivity champions.





Productivity is also doing more with less. The CVS FERRARI Heavy Trucks deliver lower fuel consumption, require less maintenance and suffer less downtime than any other competing machinery. Facts confirmed by hundreds of successful case studies across dozens of different material handling applications worldwide.



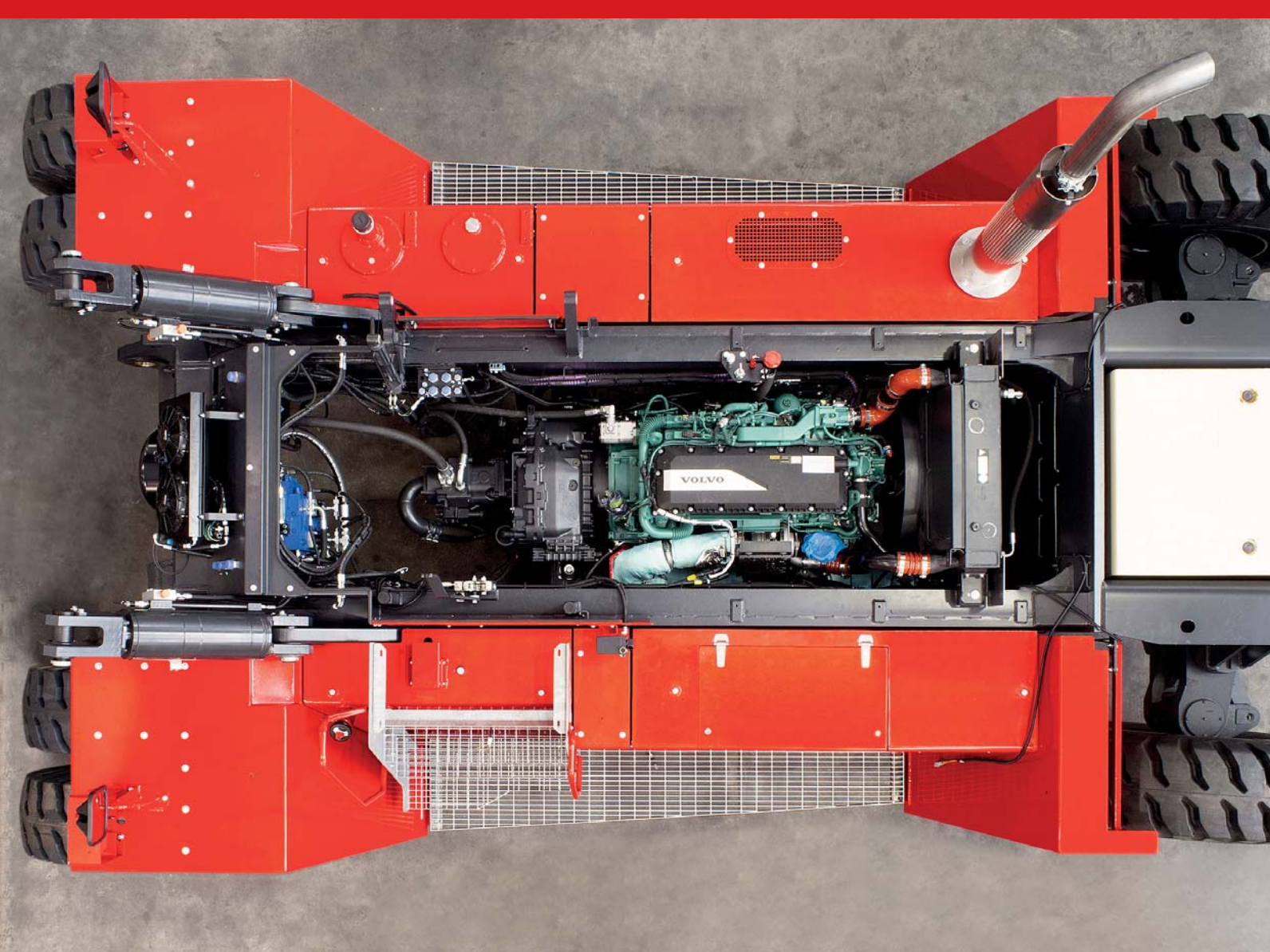

The best machines are always made with the best components and with the best manufacturing processes. That is why at CVS FERRARI we never compromise on quality and our Big Forklifts are no exception to this principle. They are fitted with powertrains, hydraulics and electrics that are oversized and produced by world leading manufacturers. We combine the quality of our components with experience and attention to detail to deliver both exceptional performance plus superior service access integrated within a modular chassis which is boxed welded structure type and it is entirely made of high resilience steel.

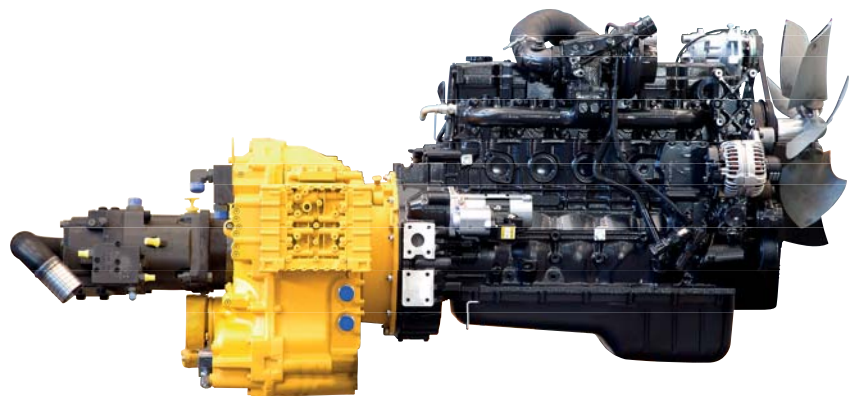
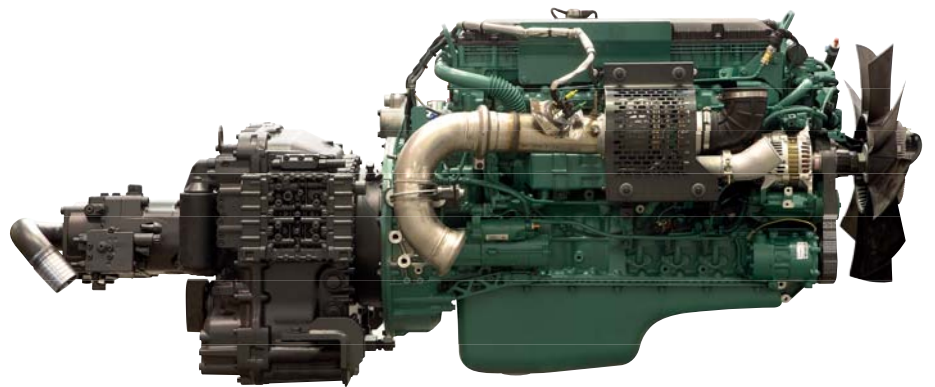



QUALITY EVERYWHERE

The variable displacement piston pumps and the load sensing distribution valve are electronic controlled by the CVS FERRARI landmark SIXTH SENSE system which minimizes fuel consumption and engine stalling whilst maximizing both speed and control of hoist. Lifting big load has never been this easy.

Hydraulic and transmission oil are forced air cooled by a radiator with a thermostatically controlled hydraulic powered fan. Our electric system is entirely CAN-BUS architecture. All control units are enclosed in a handily accessible and fully protected compartment. All electric boxes are IP67 rated and insulated. Connectors are all aluminium type, military specification compliant.

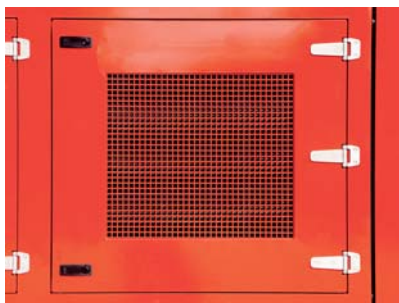



Hydraulic Side-Shift and Fork Positioning with nearly Kissing Forks are a standard feature.

STRONG AND STURDY GIANTS

The BIG FORKLIFTS that we build at CVS FERRARI are calculated to offer the longest design life in the industry and are designed to withstand the heaviest applications and the hardest working environments. The masts of our trucks are precisely machined after they have been welded - this way ensuring perfect alignment of all its elements and minimizing play and fatigue throughout the entire structure. They are fitted with large rollers mounted on press fit spindles.





The CVS FERRARI heavy forklifts are renowned for their over-engineered chassis, their structural rigidity and their effortless performance in any operational environment. Durable like no others, these trucks are made to prevail no matter how arduous and fatiguing the application. Whatever the task, whatever the situation these machines will deliver over and over again.



Drive and Steer Axles are heavy duty and wide track type. The front rigid Drive axle has oil cooled wet disc brakes. The rear oscillating Steer axle is a sandwich structure design with an oversized kingpin, spindle, and bearing assembly. Rubber shock absorbers are a standard feature. The sandwich design of the steer axle facilitates very high wheel turning angles that give the machines unrivalled manoeuvrability.





POWER IN CONTROL

Great power needs great control to produce perfect results. The CVS FERRARI heavy Liftrucks are at the forefront of the industry when it comes to machine control and human interface technology. A rugged automotive style on-board computer is fitted that controls all the machine systems activities and manages our trucks. This control delivers enhanced component protection and fault diagnostic as well as an unprecedented level of safety. Load Moment Indicator and Limiter is a standard feature for all CVS FERRARI liftrucks along with the contactless, dead man handle type joystick.

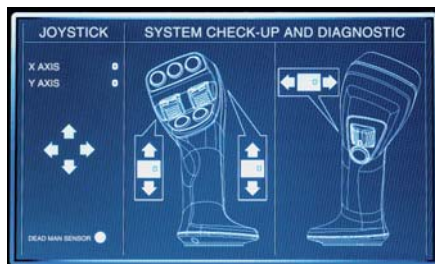

OPERATIONAL STATS			
	TOTALS	AVERAGES	
Working Hours	6.680	Lifts / Working Hour	12.31
Idle Hours	812	Tonnes / Working Hour	253.79
Hydraulics Work Hours	1.025	km / Working Hour	3.98
Consumed Fuel in Litres	101.046	Tonnes / Lift	20.52
Handled Containers (Lifts)	82.212	km/Lit	0.32
Lifted Load (Tonnes)	1.895.318	Idle Time per W. Hour	12%
Distance Travelled (km)	26.617	Hydraulic Work per W. Hour	15%



The Driver of a CVS FERRARI Heavy Forklift operates in a solid, safe spacious and comfortable environment. The ARIA cab has round and sun deflecting laminated glasses and is perfectly sound and temperature insulated. Its visibility and solidity are top class derived from the recessed front pillars and the FOPS upper glass. In its standard configuration it is the most complete and luxurious operator environment in the market.





EASY TO ACCESS SIMPLE TO SERVICE

At CVS FERRARI we know that even the most enduring and reliable machines need to be serviced and maintained - and that maintenance and service should be made as easy and elementary as possible.





That is why in our heavy trucks the hydraulic side tilting cab is a standard feature. As standard is the service bay where normally hard to reach filters and other service items have been handily relocated. That is why our engine is accessible from both sides of the truck and why our electrics are consolidated in a protected and easily accessible lockable compartment. The value of any equipment is also a function of how simple and inexpensive it is to service and maintain. CVS has conceived its new FH range of Heavy Duty Fork Lifts to be machines on which the technician can work hands down with total comfort and safety.

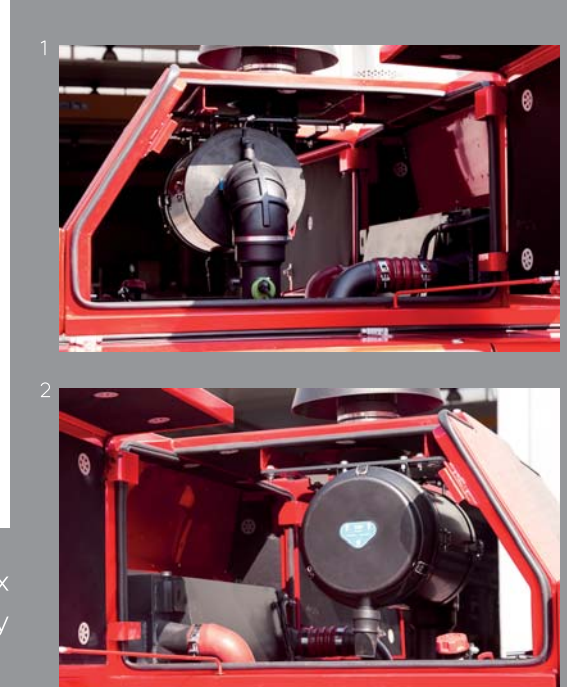

1 - 2_Engine air filter access - 3_Fuses and relays box
 4_Batteries compartment - 5_Engine & transmission service bay
 6_Brake system service bay



The CVS FERRARI new FH range of Heavy Forklifts has been developed to interface a wide series of attachments, most of which are designed and manufactured in-house by CVS FERRARI.

Single or multiple coil rams, coil rotating clamp, wide and telescopic carriages, side tilting carriages, magnets, tongues, log clamps, special spreaders etc. are all tools with which you can equip your CVS FERRARI liftruck to handle almost any cargo with maximum efficiency.

We at CVS are experts in providing bespoke solutions for specialist applications worldwide and we guarantee that have a machine and attachment to satisfy your needs.



TOTAL FLEXIBILITY

PROFESSIONAL ATTACHMENTS INTEGRATION



Magnet system lay-out has been studied to keep all components in gauge and to safeguard full rear visibility and optimum service accessibility.



ALL WHEEL DRIVE
version available
for 16 to 25 Ton
capacity models.



RoRo Version
available for
25 to 42 Ton
capacity models.



FERRARI

CVS FERRARI S.R.L.
VIA EMILIA LOC FAVORITA
29010 ROVELETO DI CADEO (PC) ITALY
Tel. +39.0523.503511
www.cvsferrari.com

www.badini.com

