

J1-192

TASK SUPPORT VEHICLE

U.S. Patent Nos. D730,614; D733,389; D733,390; D734,589; 9,440,830 B2 and 10,214,402

Maintenance Repair Parts Manual

NOTE: This vehicle is for indoor and level surface use only.

NOTE: For the most current parts information and service updates,
please refer to the Big Joe Support site at www.bigjoesupport.com

WARNING

Do not operate this vehicle unless you have been authorized and trained to do so, and have read all warnings and instructions in Operator's Manual and on this vehicle. Read, understand and comply with the information on the vehicle's nameplate at all times.

Do not operate this vehicle until you have performed the daily operation's check list. Verify and inspect tires, horn, battery, controller, lift and hydraulic systems, brakes, steering mechanism and guards. Verify that all emergency controls, personal protection and safety devices are in place and functioning correctly and ensure the vehicle is free of fluid leaks and has no loose or missing parts. Report any problems to the designated authority and do not use the vehicle until they are corrected by a qualified mechanic.

This vehicle must not be modified without the manufacturer's consent. Components critical to the vehicles stability such as batteries shall not be replaced with lighter weight components.

Operate vehicle only from designated platform operating position. Use this vehicle indoors on level surfaces only. Never operate on ramps and slopes or uneven floors. This vehicle is not for use on mezzanines or balcony areas. Before operating, inspect the floor area it will be used on and be certain it will support the vehicle at full capacity and lift height. Identify and avoid holes, drop-offs, bumps and obstructions.

Before and during all vehicle operations ensure that adequate clearance is maintained from overhead obstructions and energized electrical conductors and parts.

Before elevating platform be sure guardrail access gates are in place and lowered. Keep feet on platform floor at all times while using vehicle, never climb onto guard rails or platform shelf. Do not use ladders, planks or other devices to achieve additional height on platform.

When transferring loads to platform or platform shelf, do not exceed capacity ratings on vehicle nameplate. Ensure loads are centered and do not contact any obstructions in the vehicle's vicinity. Do not stabilize the platform by contact with adjacent objects such as racks or shelving. Do not use the platform as a crane.

Take care to prevent electrical cords, hoses or other equipment from entangling in platform. Ensure area surrounding the vehicle is free of personnel and equipment before lowering platform.

Maintain a clear view of the ground while travelling and a safe distance from obstacles in the vehicle or platform's path. Ensure personnel in the vicinity are aware of the vehicle's movement. Travel at a safe speed for the conditions the vehicle is operating in.

Observe applicable traffic regulations. Yield right of way to pedestrians. Slow down and sound horn at cross aisles and wherever vision is obstructed. Avoid hazardous locations.

Enter and exit platform only through raised access gates and with the platform fully lowered and vehicle stopped. When leaving vehicle unattended, remove key to prevent unauthorized use.

| Section | Page | Section | Page |
|--|------|---|------|
| 1 DESCRIPTION | 1-1 | 6-2.1 REMOVAL | 6-2 |
| 1-1 INTRODUCTION | 1-1 | 6-2.2 INSTALLATION | 6-2 |
| 1-2 GENERAL DESCRIPTION | 1-1 | 6-3 DRIVE WHEEL | 6-2 |
| 1-3 DATA PLATE AND WARNING DECAL | 1-2 | 6-4 CASTER | 6-2 |
| 1-4 INSTALL /WARRANTY CHECK LIST | 1-2 | 7 ELEVATION SYSTEM SERVICING | 7-1 |
| 2 PLANNED MAINTENANCE..... | 2-1 | 7-1 GENERAL..... | 7-1 |
| 2-1 GENERAL..... | 2-1 | 7-2 LIFT CHAIN LENGTH ADJUSTMENT | 7-1 |
| 2-2 MONTHLY AND QUARTERLY CHECKS..... | 2-1 | 7-3 LIFT CHAIN WEAR INSPECTION | 7-2 |
| 2-3 FREQUENT INSPECTIONS..... | 2-1 | 7-4 LIFT CHAIN REPLACEMENT | 7-2 |
| 2-4 ANNUAL INSPECTIONS | 2-1 | 7-4-1 THREE STAGE MAST | 7-2 |
| 2-5 BATTERY CARE | 2-1 | 7-4.1.1 MAST LIFTING CHAIN | 7-2 |
| 2-5.1 GENERAL | 2-1 | 7-4.1.2 PLATFORM LIFTING CHAIN | 7-2 |
| 2-5.2 SAFETY RULES | 2-2 | LIFT CYLINDERS. 7 | |
| 2-5.3 MAINTENANCE PERSONNEL..... | 2-2 | HYDRAULIC SYSTEM SERVICING 1 | |
| 2-5.4 BATTERY CARE AND CHARGING | 2-2 | LINES AND FITTINGS 1 | |
| 2-5.5 BATTERY CLEANING | 2-2 | HYDRAULIC PUMP, MOTOR, AND RESERVOIR | |
| 2-5.6 MAINTENANCE FREE BATTERIES | 2-2 | ASSY 1 | |
| 2-6 CHARGING BATTERIES | 2-3 | REMOVAL 1 | |
| 2-7 REPLACING BATTERIES | 2-3 | DISASSEMBLY AND REASSEMBLY 1 | |
| 2-7.1 BATTERY DISPOSAL | 2-3 | INSTALLATION 3 | |
| 2-8 LUBRICATION..... | 2-4 | LIFT CYLINDER (FULL FREE LIFT) 3 | |
| 2-9 LIFT CHAIN MAINTENANCE..... | 2-4 | REMOVAL 3 | |
| 3 TROUBLESHOOTING..... | 3-1 | REPAIR 3 | |
| 3-1 GENERAL..... | 3-1 | INSTALLATION 3 | |
| 3-2 CONTROLLER TROUBLESHOOTING | 3-4 | LIFT CYLINDER (THREE STAGE MAST SECOND- | |
| 3-2.1 ZAPI HANDSET | 3-4 | ARY) 8 | |
| 3-2.2 FAULT DETECTION | 3-4 | REMOVAL 8 | |
| 3-2.2.1 GENERAL..... | 3-4 | REPAIR 8 | |
| 3-2.2.2 LOGBOOK ACCESS | 3-4 | INSTALLATION 9 | |
| 3-2.3 TESTING TRUCK OPERATION | 3-4 | ELECTRICAL COMPONENTS 1 | |
| 3-2.4 FACTORY SETTINGS | 3-5 | ELECTRICAL CONTROL PANEL 1 | |
| 4 STEERING SYSTEM..... | 4-1 | MAINTENANCE 1 | |
| 4-1 CONTROL ARM | 4-1 | CLEANING 1 | |
| 4-1.1 STEERING CONTROL REMOVAL | 4-1 | PANEL REMOVAL. 1 | |
| 4-1.2 STEERING CONTROL | | PANEL DISASSEMBLY. 1 | |
| INSTALLATION | 4-2 | PANEL INSTALLATION. 1 | |
| 4-2 COMPARTMENT COVER..... | 4-2 | HORN REPLACEMENT. 1 | |
| 4-2.1 COVER REMOVAL..... | 4-2 | LOWERING BUZZER REPLACEMENT. 3 | |
| 4-2.2 COVER INSTALLATION..... | 4-2 | LEVEL SENSOR BUZZER REPLACEMENT. 3 | |
| 4-3 STEER MOTOR | 4-2 | LEVEL SENSOR REPLACEMENT. 3 | |
| 4-3.1 MOTOR REMOVAL | 4-2 | WARNING LIGHT REPLACEMENT. 3 | |
| 4-3.2 MOTOR INSTALLATION..... | 4-3 | BATTERY REPLACEMENT. 3 | |
| 5 BRAKE SERVICING..... | 5-1 | BATTERY CHARGER. 3 | |
| 5-1 BRAKES | 5-1 | REMOVAL. 3 | |
| 5-1.1 BRAKE ASSY. REPLACEMENT | 5-1 | INSTALLATION. 3 | |
| 6 TRANSMISSION, DRIVE WHEEL, | | PLATFORM CABLE REPLACEMENT.. 4 | |
| LOAD WHEEL AND CASTERS..... | 6-1 | THREE STAGE MAST 4 | |
| 6-1 TRANSMISSION AND DRIVE MOTOR. | 6-1 | OPTIONAL EQUIPMENT 1 | |
| 6-2 LOAD WHEEL. | 6-2 | INDUSTRIAL BATTERY 1 | |
| | | ILLUSTRATED PARTS BREAKDOWN 1 | |

SECTION 1 DESCRIPTION

1-1. INTRODUCTION.

This publication describes the 24 volt J1 task support vehicle by Big Lift LLC. Included are planned maintenance instructions, lubrication procedures, corrective maintenance procedures and a complete parts list with part location illustrations.

Users shall comply with all requirements indicated in applicable OSHA standards and the current edition of A.N.S.I. A92.6. By following these requirements and the recommendations contained in this manual, you will receive many years of dependable service from your J1 task support vehicle.

1-2. GENERAL DESCRIPTION.

The self-propelled J1 task support vehicle lifts and transports up to 1,000 pounds capacity including load and operator. The vehicle enables general maintenance work and efficient selection and moving of materials in any area or at any level of the warehouse or storeroom. This vehicle is not for use on mezzanines or balcony areas. The design permits one man to perform all operations of selecting stock, driving vehicle, and replacing the stock at the designated place. The battery-powered vehicle is quiet and allows operation in closed areas without special provisions for ventilation.

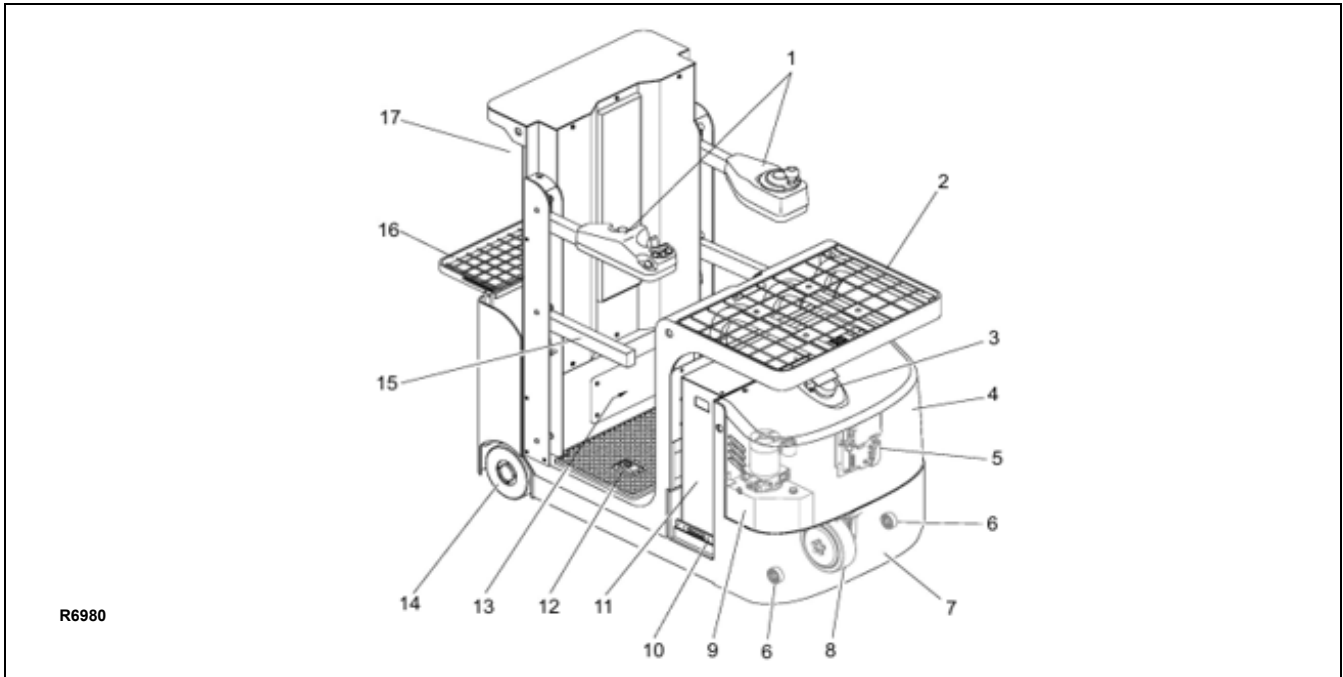

Figure 1-1 J1 Elevating Work Platform

| ITEM | COMPONENT |
|------|------------------------------|
| 1 | Control arms |
| 2 | Pick tray |
| 3 | Warning light |
| 4 | Cover |
| 5 | Control panel |
| 6 | Casters |
| 7 | Frame |
| 8 | Drive wheel |
| 9 | Hydraulic pump and reservoir |

| ITEM | COMPONENT |
|------|---|
| 10 | Battery retainer |
| 11 | Battery |
| 12 | “Deadman” footswitch |
| 13 | Operator platform |
| 14 | Load wheels |
| 15 | Side gates |
| 16 | Rear tray for additional capacity and storage |
| 17 | Mast |

The AC motor propels the vehicle in forward or reverse direction. The vehicle can be driven with the platform raised or lowered; however the speed is restricted above 24".

On demand power steering makes the vehicle highly maneuverable.

The control arms are used to operate the work vehicle and provide operator safety.

The pick tray is used to place and transport merchandise, equipment and tools.

The operator platform contains the "deadman" footswitch which must be depressed for the vehicle to operate.

The folding rear tray provides for transporting up to a 200 pound load.

1-3. DATA PLATE AND WARNING DECAL.

Warning decals are located to the left of the Instrument panel. The data plate is mounted on the right side of the Instrument panel.

If the data plate or warning decals are lost or damaged they MUST be replaced immediately. Have your supervisor or the designated authority contact Big Lift LLC Authorized Dealer for replacement.

The data plate shows the model, serial number, capacity, lift height, vehicle weight and minimum battery weight. See Figure 1-2.

1-4. INSTALLATION / WARRANTY CHECK LIST.

The Big Lift, LLC Installation and Warranty Registration Reports are used to initiate the start of the warranty period to the first original end user.

This report also serves as documentation that all items on the Installation and Warranty Registration Report were reviewed and discussed with the end user prior to taking receipt of the equipment.

This report must be completed and returned to Big Lift, LLC within fifteen (15) days of receipt of equipment. (See "page 1-3" for a copy of the form, also available at www.bigjoesupport.com)

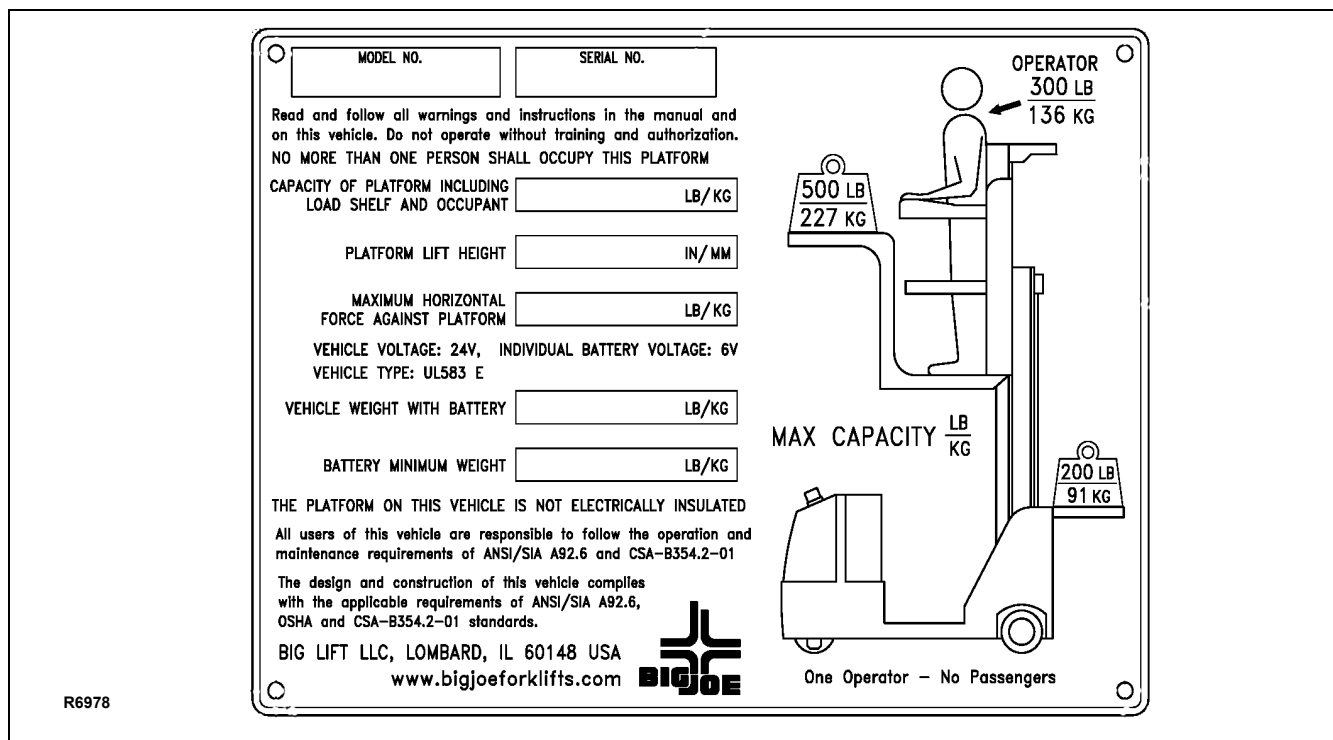

Figure 1-2 J1 Data Plate



Installation and Warranty Registration for Big Lift J1 vehicles

Instructions: Complete form, provide a copy for the customer and return a copy via e-mail, fax or mail to:

Big Lift LLC.
1060 N. Garfield Street
Lombard, IL 60148
Tel.#: 630-916-2600
Fax.#: 630-916-0657
E-mail: sales@bigjoeforklifts.com

CUSTOMER MUST FILE CLAIM WITH CARRIER FOR ANY DAMAGE RECEIVED IN TRANSIT.

| | |
|--------------------------|-------------|
| DATE EQUIPMENT RECEIVED: | CUSTOMER: |
| | ADDRESS: |
| INSTALLATION DATE: | CITY: |
| | STATE: |
| | ZIP/POSTAL: |
| | COUNTRY: |

| WARRANTY REGISTRATION | | | |
|---|--------|-------------|--|
| THIS FORM MUST BE COMPLETED AND RETURNED TO BIG LIFT LLC WITHIN 15 DAYS OF DELIVERY IN ORDER TO BEGIN WARRANTY COVERAGE. | | | |
| PLEASE NOTE THIS VEHICLE IS RATED AS AN ELEVATING WORK PLATFORM INTENDED FOR OPERATION INDOORS ON LEVEL SURFACES ONLY. PLEASE REFER TO THE J1 OPERATIONS MANUAL, MAINTENANCE MANUAL AND THE ANSI A92.6 STANDARD FOR SPECIFIC REQUIREMENTS AND GUIDELINES. | | | |
| CUSTOMER INFORMATION SECTION | | | |
| MODEL #: | | | |
| SERIAL #: | | | |
| DEALER: | | | |
| ADDRESS: | | | |
| CITY: | STATE: | ZIP/POSTAL: | |
| COUNTRY: | | | |

| VEHICLE INSTALLATION SECTION - Following to be filled out by Service Representative | | | |
|---|--------------------------|---|--------------------------|
| THE FOLLOWING HAS BEEN CHECKED PRIOR TO OR ON DELIVERY | | THE FOLLOWING MUST BE EXPLAINED OR DEMONSTRATED TO THE CUSTOMER | |
| ELECTRICAL SYSTEM | OK | ADJ. | R & R |
| ELECTRICAL CONNECTIONS PROPERLY SECURED | <input type="checkbox"/> | <input type="checkbox"/> | <input type="checkbox"/> |
| BATTERY TERMINALS PROPERLY SECURED | <input type="checkbox"/> | <input type="checkbox"/> | <input type="checkbox"/> |
| HORN AND FLASHING LIGHT | <input type="checkbox"/> | <input type="checkbox"/> | <input type="checkbox"/> |
| TRAVEL CONTROLS, FWD. / REV. | <input type="checkbox"/> | <input type="checkbox"/> | <input type="checkbox"/> |
| EMERGENCY BRAKE SWITCH | <input type="checkbox"/> | <input type="checkbox"/> | <input type="checkbox"/> |
| BATTERY DISCONNECT PLUGS | <input type="checkbox"/> | <input type="checkbox"/> | <input type="checkbox"/> |
| HIGH SPEED LIMIT SWITCH | <input type="checkbox"/> | <input type="checkbox"/> | <input type="checkbox"/> |
| LIFT / LOWER CONTROLS | <input type="checkbox"/> | <input type="checkbox"/> | <input type="checkbox"/> |
| BRAKES | OK | ADJ. | R & R |
| REVERSE BRAKING OPERATION | <input type="checkbox"/> | <input type="checkbox"/> | <input type="checkbox"/> |
| COAST BRAKING OPERATIONS | <input type="checkbox"/> | <input type="checkbox"/> | <input type="checkbox"/> |
| HYDRAULICS | OK | ADJ. | R & R |
| PROPER OIL LEVEL | <input type="checkbox"/> | <input type="checkbox"/> | <input type="checkbox"/> |
| PUMP AND MOTOR MOUNTING SECURE | <input type="checkbox"/> | <input type="checkbox"/> | <input type="checkbox"/> |
| CHECK FOR LEAKS ON CYLINDERS | <input type="checkbox"/> | <input type="checkbox"/> | <input type="checkbox"/> |
| CHECK FOR LEAKS ON HYDRAULIC PUMP / TANK | <input type="checkbox"/> | <input type="checkbox"/> | <input type="checkbox"/> |
| CHECK FOR LEAKS ON HOSES AND FITTINGS | <input type="checkbox"/> | <input type="checkbox"/> | <input type="checkbox"/> |
| STEERING | OK | ADJ. | R & R |
| ELECTRONIC POWER STEERING OPERATION | <input type="checkbox"/> | <input type="checkbox"/> | <input type="checkbox"/> |
| MAST ASSEMBLY | OK | ADJ. | R & R |
| LIFT CHAIN TENSION | <input type="checkbox"/> | <input type="checkbox"/> | <input type="checkbox"/> |
| COTTER KEYS IN ANCHOR PINS | <input type="checkbox"/> | <input type="checkbox"/> | <input type="checkbox"/> |
| LUBRICATION OF MAST CHANNEL, BEARINGS AND RAM HEAD | <input type="checkbox"/> | <input type="checkbox"/> | <input type="checkbox"/> |
| OTHER | OK | ADJ. | R & R |
| PICK TRAY AND REAR TRAY OPERATION | <input type="checkbox"/> | <input type="checkbox"/> | <input type="checkbox"/> |
| CONTROL ARMS AND GUARD RAILS | <input type="checkbox"/> | <input type="checkbox"/> | <input type="checkbox"/> |
| SAFETY WARNING LABELS AND NAME PLATE | <input type="checkbox"/> | <input type="checkbox"/> | <input type="checkbox"/> |
| WHEELS | <input type="checkbox"/> | <input type="checkbox"/> | <input type="checkbox"/> |
| PLATFORM OPERATION | <input type="checkbox"/> | <input type="checkbox"/> | <input type="checkbox"/> |
| DRIVE WHEEL | <input type="checkbox"/> | <input type="checkbox"/> | <input type="checkbox"/> |
| LOAD WHEELS | <input type="checkbox"/> | <input type="checkbox"/> | <input type="checkbox"/> |
| CASTER WHEELS | <input type="checkbox"/> | <input type="checkbox"/> | <input type="checkbox"/> |

CUSTOMER AND DEALER SIGN OFF

THE SERVICING DEALER, OWNER, SUPERVISOR AND OPERATOR SHOULD ENSURE THAT THE VEHICLE IS ONLY OPERATED INDOORS ON LEVEL SURFACES. FLOORS SHOULD BE CLEAN AND CLEAR OF DEBRIS AND OBSTRUCTIONS.

PLANNED MAINTENANCE IS REQUIRED ON THIS VEHICLE PER THE ANSI GUIDELINES. BE SURE TO REFERENCE ANSI A92.6 FOR SPECIFIC PM REQUIREMENTS.

IT IS THE RESPONSIBILITY OF THE SERVICING DEALER, OWNER, SUPERVISOR AND OPERATOR TO ENSURE THE APPROPRIATE ONSITE INSPECTION AND TRAINING HAS TAKEN PLACE PRIOR TO USAGE. PLEASE SEE ANSI A92.6 GUIDELINES FOR COMPLETE REQUIREMENTS.

THIS MACHINE HAS BEEN RECEIVED IN SATISFACTORY CONDITION. WE HAVE RECEIVED PROPER INSTRUCTION REGARDING OPERATION, MAINTENANCE AND SAFETY PRACTICES.

CUSTOMER SIGNATURE: _____

PRINTED NAME: _____ **DATE:** _____

AT THE TIME OF DELIVERY, THE OWNER'S AND OPERATOR'S MANUAL AND WARRANTY POLICY WERE PRESENTED AND EXPLAINED. THE DELIVERY SERVICE WAS CONDUCTED AS NOTED ABOVE.

DEALER SIGNATURE: _____

PRINTED NAME: _____ **DATE:** _____

NOTES

SECTION 2 PLANNED MAINTENANCE

2-1. GENERAL.

Planned maintenance consists of periodic visual and operational checks, inspection, lubrication, and scheduled maintenance designed to catch an issue in the early hours or discover malfunctions and defective parts. The operator performs the checks in the Operator's Manual, and refers any required servicing to a qualified maintenance technician who performs the planned maintenance and any required servicing.

2-2. MONTHLY AND QUARTERLY CHECKS.

Table 2-1 is a monthly and quarterly inspection and service chart based on normal usage of equipment eight hours per day, five days per week. If the vehicle is used in excess of forty hours per week, the frequency of inspection and service should be increased accordingly. These procedures must be performed by a qualified service technician or your Big Lift LLC Service Representative.

2-3. FREQUENT INSPECTIONS.

The owner and user are required by ANSI A92.6 to ensure frequent inspections of the J1 Task Support Vehicle occur and are performed in accordance with the following points: 1. If purchased used unless it's determined that the frequent and annual inspections are current. 2. The J1 Task Support Vehicle has been in service for three (3) months or 150 hours, whichever comes first. 3. The J1 Task Support Vehicle has been out of service for a period longer than three (3) months. inspection is to be performed by a mechanic that is qualified and authorized to perform service on the J1 Task Support Vehicle. All service records must be maintained. (See "Page 2-6" and "Page 2-7" for copy of inspection sheet, also available at www.bigjoesupport.com).

2-4. ANNUAL INSPECTIONS.

The owner and user are required by ANSI A92.6 to ensure annual inspections of the J1 Task Support Vehicle occur and are performed no later than 13 months from the date of prior annual inspection or every 700 hundred hours of use, whichever occurs first. This annual inspection is to be performed by a mechanic that is qualified and authorized to perform service on the J1 Task Support Vehicle. All service records must be maintained. (See "Page 2-6" and "Page 2-7" for copy of inspection sheet, also available at www.bigjoesupport.com).

2-5. BATTERY CARE.

2-5.1. General

The vehicle may be equipped with maintenance free batteries.

The care and maintenance of the battery is very important to obtain efficient vehicle operation and maximum battery life.

CAUTION: Gases produced by a battery can be explosive. Do not smoke, use an open flame, create an arc or sparks in the vicinity of the battery. Ventilate an enclosed area well when charging.

CAUTION: Batteries contain sulfuric acid which may cause severe burns. Avoid contact with eyes, skin or clothing. In case of contact, flush immediately and thoroughly with clean water. Obtain medical attention when eyes are affected. A baking soda solution (one pound to one gallon of water) applied to spilled acid until bubbling stops, neutralizes the acid for safe

Table 2-1 Monthly and Quarterly Inspection and Service Chart

| VISUAL CHECKS | |
|---------------|--|
| INTERVAL | INSPECTION OR SERVICE |
| Monthly | Check electrical brake for proper operation. |
| Monthly | Inspect wiring for loose connections and damaged insulation. |
| Monthly | Check wheels for wear and damage. |
| Monthly | Check "deadman" footswitch for proper operation. |
| Monthly | Check lift chain tension, lubrication & operation (see paragraph 2-9.) |
| Quarterly | Check lift cylinder for leakage. |
| Quarterly | Test electric steering. |
| Quarterly | Check steering gear for wear and lubricate. |
| Semi-annually | Inspect for chain wear (See SECTION 7) |

2-5.2. Safety Rules

- Wear protective clothing, such as rubber apron, gloves, boots and goggles when performing any maintenance on batteries. Do not allow electrolyte to come in contact with eyes, skin, clothing or floor. If electrolyte comes in contact with eyes, flush immediately and thoroughly with clean water. Obtain medical attention immediately. Should electrolyte be spilled on skin, rinse promptly with clean water and wash with soap. A baking soda solution (one pound to one gallon of water) will neutralize acid spilled on clothing, floor or any other surface. Apply solution until bubbling stops and rinse with clean water.
- Do not bring any type of flame, spark, etc., near the battery. Gas formed while the battery is charging, is highly explosive. This gas remains in cell long after charging has stopped.
- Do not lay metallic or conductive objects on battery. Arcing will result.
- Do not touch non-insulated parts of DC output connector or battery terminals to avoid possible electrical shock.
- Disconnect all AC and DC power connections before servicing battery.
- Do not charge a frozen battery.
- Do not use charger if it has been dropped or otherwise damaged.

2-5.3. Maintenance Personnel

Batteries may only be charged, serviced or replaced by trained personnel. This manual and the manufacturer's instructions concerning batteries and charging stations must be observed when carrying out the work.

2-5.4. Battery Care and Charging

CAUTION: Never smoke or bring open flame near the battery. Gas formed during charging is highly explosive and can cause serious injury.

1. Charge the battery only in areas designated for that use.
2. Battery terminals should be checked and cleaned of corrosion regularly. Good battery terminal contact is essential not only for operation, but also for proper charging of the battery.
3. Make certain battery used meets weight and size requirements of vehicle. NEVER operate vehicle with an undersized battery.

2-5.5. Battery Cleaning

Always keep vent plugs tightly in place when cleaning battery. When properly watered and charged, the battery will remain clean and dry. All that is necessary is to brush or blow off any dust or dirt that may accumulate on them. However, if electrolyte is spilled or overflows from a cell, it should be neutralized with a solution of baking soda and water, brushing the soda solution beneath the connectors and removing grime from the covers. Then rinse the battery with cool water from a low pressure supply to remove the soda and loosen dirt. If batteries stay wet consistently, they may be either overcharged or over filled. This condition should be investigated and corrected.

2-5.6. MAINTENANCE FREE BATTERIES

Some vehicles may be equipped with maintenance free batteries. These batteries are completely sealed, will not require any watering and have a full 80% discharge available.

Sealed Maintenance Free batteries contain a pressure release valve and under normal operating conditions do not require any special ventilation.

CAUTION: Do not try to open this battery or remove the pressure release valve.

Only under severe overcharging, such as connected to an improperly sized charger, will any significant amount of gases be released from the battery. Also, being a valve regulated battery, it never requires watering.

2-6. CHARGING BATTERIES

Charging requirements will vary depending on depth of discharge and temperature. Follow safety rules when placing a battery on charge.

Proceed as follows:

1. Park vehicle at charging station with platform lowered and turn the key switch OFF.
2. Apply the emergency disconnect switch.
3. Check the condition of the AC cord and battery cables. If there are any cuts in the cable, any exposed wires, loose plugs or connectors, DO NOT attempt to charge the batteries.
4. Disconnect plug (1, [Figure 2-1](#)) from the vehicle and connect it to charger's plug (2).
5. Connect cord (3) and charge the battery according to Supplement 374 *.
6. Disconnect the charger cord and insert it in its receptacle on the vehicle.

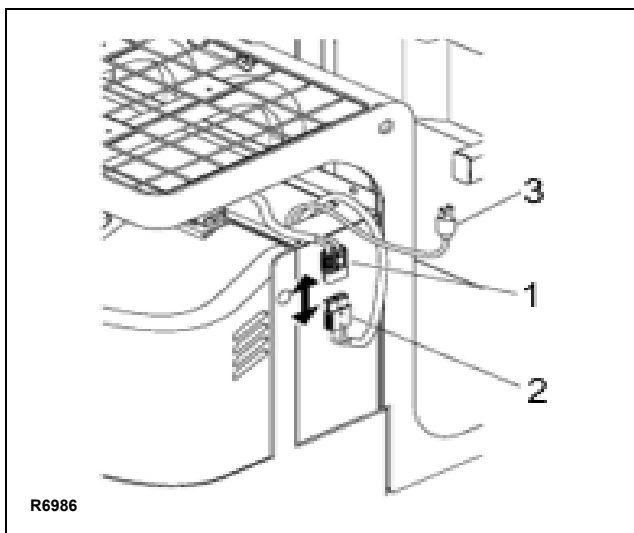

Figure 2-1 Battery Charging

2-7. REPLACING BATTERIES

Replace only with original OEM batteries or batteries approved by an authorized Big Lift LLC dealer. Contact your authorized Big Joe dealer for information on optional batteries and battery chargers.

1. Park vehicle at charging station with platform lowered and turn the key switch OFF.
2. Apply the emergency parking brake.

3. Disconnect the battery from the vehicle and place the battery plug and cable in such a way that they will not get caught on the vehicle when the battery is removed.

4. Remove retainer (2, [Figure 2-2](#)).

WARNING: Take caution when removing the battery pack or optional industrial battery from the vehicle. Battery is located on battery rollers. Use of a battery stand is recommended when removing the battery. Only an authorized Big Joe dealer should be used for battery removal and installation.

5. Remove battery (1) out the side of the vehicle.

6. Install in reverse order.

WARNING: The weight and dimensions of the battery have considerable affect on the operational safety of the vehicle. Battery equipment may only be replaced with the agreement of the manufacturer.

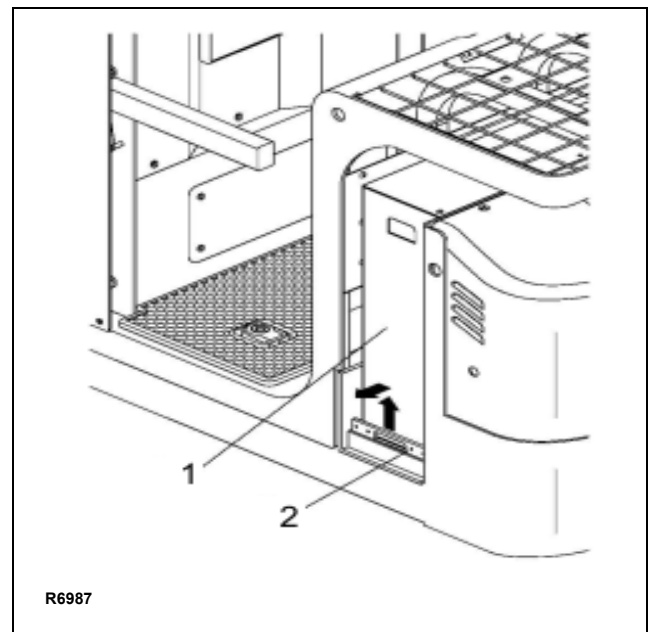

Figure 2-2 Battery Replacement

2-7.1. Battery disposal:

Dispose in accordance with national environmental protection regulations or disposal laws. The manufacturer's disposal instructions must be followed

* Please refer to the Big Joe Support site at www.bigjoesupport.com



2-8. LUBRICATION.

Refer to [Table 2-2](#) for the recommended types of grease and oil. [Table 2-3](#) in conjunction with [Figure 2-3](#) identifies the items requiring lubrication.

2-9. LIFT CHAIN MAINTENANCE.

Fully raise and lower lift carriage while observing chains as they move over chain sheaves. Ensure chain is aligned and tracking properly and all links are pivoting freely. With lift carriage fully lowered, spray on a film of Moly Chain Lube. For more information see [SECTION 7](#)

**Table 2-2 Recommended Lubricants
(See [Table 2-3](#) for Application)**

| | |
|-------|------------------------|
| No. 1 | Grease—Polylub GA352P |
| No. 2 | Hydraulic oil—L-HM46#. |

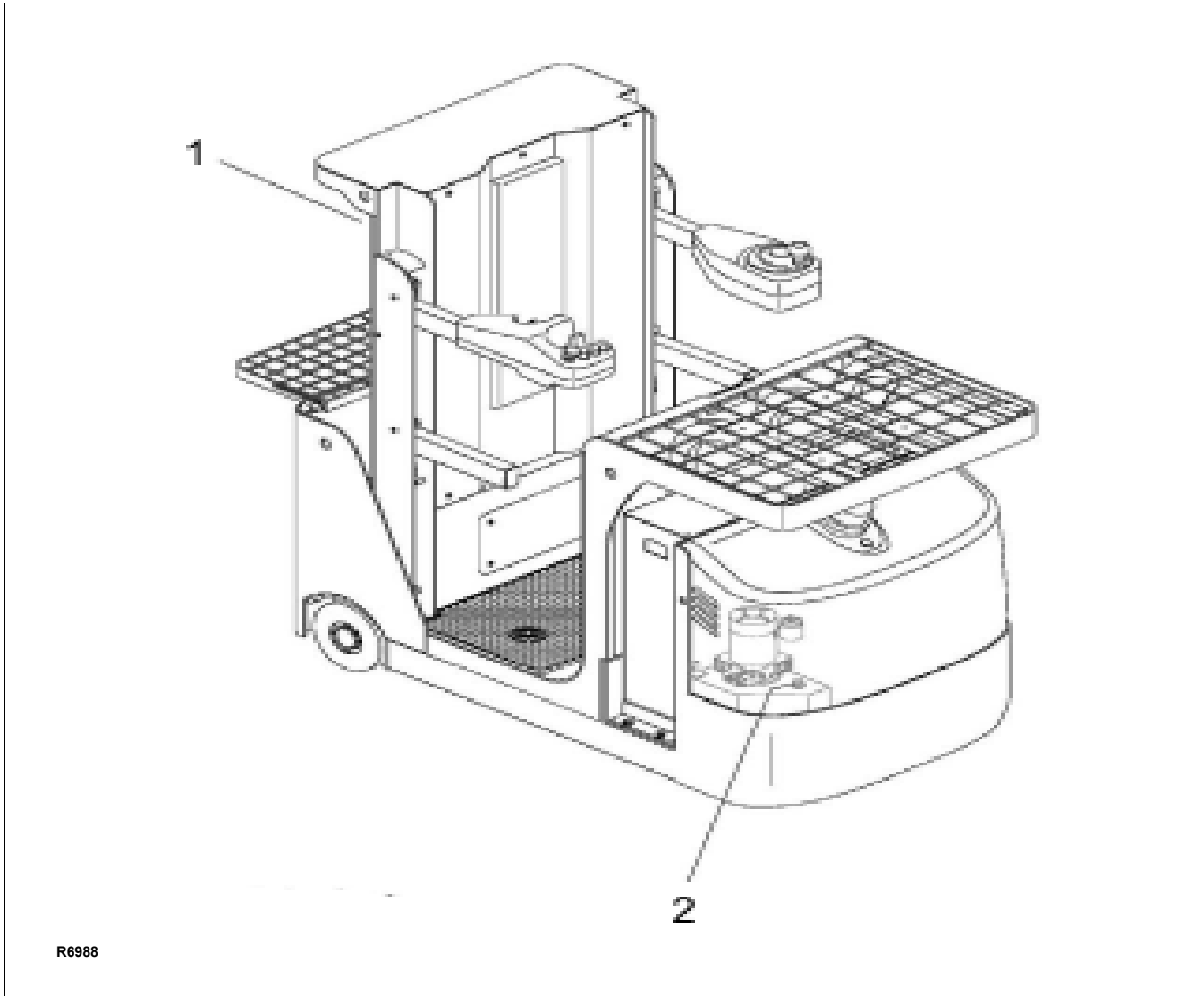

Figure 2-3 Lubrication Diagram

Table 2-3 Lubrication Chart

| FIG 3-2 INDEX NO. | LOCATION | METHOD OF APPLICATION | TYPE (Table 2-3) | APPLICATION OF LUBRICANT |
|----------------------------------|---------------------|----------------------------------|---------------------------------|---|
| 1 | Mast | Spray | No. 1 | Full length of channel where rollers operate. |
| 2 | Hydraulic Reservoir | Can | No. 2 | With platform fully lowered, fill reservoir with hydraulic oil to level on dip stick. |



Big Lift LLC.
1060 N. Garfield St.
Lombard, IL 60148

J1 - Task Support Vehicle (TSV)
Annual Inspection Report

www.bigjoesupport.com

| DEALER INFORMATION | | | | OWNER / END USER INFORMATION | | | |
|----------------------|--|----------|--|------------------------------|--|-------------|--|
| COMPANY: | | | | COMPANY: | | | |
| ADDRESS: | | | | ADDRESS: | | | |
| CITY/STATE/ZIP: | | | | CITY/STATE/ZIP: | | | |
| VEHICLE INFORMATION: | | | | | | | |
| MODEL: | | SERIAL: | | MAST SIZE: | | HOUR METER: | |
| BATTERY SPEC.: | | OPTIONS: | | PREVIOUS INSPECTION: | | | |

| INSPECTION REQUIREMENTS per ANSI A92.6 (ANNUAL AND FREQUENT) |
|---|
| <p>ANNUAL INSPECTION: The owner and user are required by ANSI A92.6 to ensure annual inspections of the J1 Task Support Vehicle occur and are performed no later than 13 months from the date of prior annual inspection or every 700 hundred hours of use, whichever occurs first. This annual inspection is to be performed by a mechanic that is qualified and authorized to perform service on the J1 Task Support Vehicle. All service records must be maintained.</p> |
| <p>FREQUENT INSPECTIONS: The owner and user are required by ANSI A92.6 to ensure frequent inspections of the J1 Task Support Vehicle occur and are performed in accordance with the following points: 1. If purchased used unless it's determined that the frequent and annual inspections are current. 2. The J1 Task Support Vehicle has been in service for three (3) months or 150 hours, whichever comes first. 3. The J1 Task Support Vehicle has been out of service for a period longer than three (3) months. inspection is to be performed by a mechanic that is qualified and authorized to perform service on the J1 Task Support Vehicle. All service records must be maintained.</p> |
| <p>INSTRUCTIONS: Refer to service/maintenance manuals for specific information regarding inspection procedures and criteria. Indicate in the appropriate space as each item has been performed. If the item is found to be not acceptable, describe each discrepancy on an additional page and attach to the form. Immediate action must be taken to correct all discrepancies. The vehicle shall not be placed in service until all discrepancies have been corrected.</p> |

| Put a ✓ in the column that applies: P = Passed Inspection , F = Failed Inspection, C = Corrected | | | |
|--|--------------------------|--------------------------|--------------------------|
| FUNCTIONS and CONTROLS | P | F | C |
| Drive and operate machine to test all functions. Ensure controls operate properly and return to "off" or neutral when released. | <input type="checkbox"/> | <input type="checkbox"/> | <input type="checkbox"/> |
| Ensure emergency power disconnect switch deactivates all movement and power and that the deadman foot switch operate properly. | <input type="checkbox"/> | <input type="checkbox"/> | <input type="checkbox"/> |
| Instrument panel is clean and free of debris and dash display is functional. | <input type="checkbox"/> | <input type="checkbox"/> | <input type="checkbox"/> |
| Operator right side control arm functions properly. Horn / travel / lift / lower / accelerator buttons are functional. | <input type="checkbox"/> | <input type="checkbox"/> | <input type="checkbox"/> |
| Operator left side control arm steering wheel functions properly. | <input type="checkbox"/> | <input type="checkbox"/> | <input type="checkbox"/> |
| Emergency lower button operates properly. | <input type="checkbox"/> | <input type="checkbox"/> | <input type="checkbox"/> |
| Ensure gate switches disable travel/lift and lower functions and flashing lights on the front and rear of the vehicle. | <input type="checkbox"/> | <input type="checkbox"/> | <input type="checkbox"/> |
| The drive wheel returns to "neutral" (straight forward) when powering up the vehicle and is accurately depicted on the LCD display. | <input type="checkbox"/> | <input type="checkbox"/> | <input type="checkbox"/> |
| OPERATOR PLATFORM ASSEMBLIES | P | F | C |
| Mast sections are free of visual evidence of damage. Mast chains and cables are inspected per the Service and Maintenance Manual. | <input type="checkbox"/> | <input type="checkbox"/> | <input type="checkbox"/> |
| Mast wiring harnesses are properly installed, seated in their pulleys and that there are no frayed or broken strands. | <input type="checkbox"/> | <input type="checkbox"/> | <input type="checkbox"/> |
| Chains are adequately lubricated and are not dry or rusty. | <input type="checkbox"/> | <input type="checkbox"/> | <input type="checkbox"/> |
| Mast cover plates are in place and securely attached for each section. | <input type="checkbox"/> | <input type="checkbox"/> | <input type="checkbox"/> |
| Mast operates smoothly to full height and descends smoothly. Ensure speed cutbacks occur at appropriate heights per the maintenance manual. | <input type="checkbox"/> | <input type="checkbox"/> | <input type="checkbox"/> |
| Platform guard rails are undamaged and gates open / close freely. | <input type="checkbox"/> | <input type="checkbox"/> | <input type="checkbox"/> |
| All nuts, bolts, pins, shafts, covers, bearings and wear pads are checked for proper installation, and do not have excessive wear, cracks or distortion. | <input type="checkbox"/> | <input type="checkbox"/> | <input type="checkbox"/> |

Continued on page 2



| VEHICLE INFORMATION: | | | |
|----------------------|-------------------|------------|-------------|
| MODEL: | SERIAL: | MAST SIZE: | HOUR METER: |
| DEALER: | OWNER / END USER: | | |

| HYDRAULIC SYSTEM | P | F | C |
|---|--------------------------|--------------------------|--------------------------|
| Lift cylinder is free of damage, no evidence of leaks and that all hardware is secure and undamaged. | <input type="checkbox"/> | <input type="checkbox"/> | <input type="checkbox"/> |
| All hydraulic hoses, fittings and components are properly secured and that there is no evidence of leaks. | <input type="checkbox"/> | <input type="checkbox"/> | <input type="checkbox"/> |
| Ensure fluid level is correct in hydraulic tank. | <input type="checkbox"/> | <input type="checkbox"/> | <input type="checkbox"/> |
| Ensure hydraulic pump is secure and undamaged, operates properly and is free of leaks. | <input type="checkbox"/> | <input type="checkbox"/> | <input type="checkbox"/> |
| Ensure hydraulic control valve is secure and undamaged, operates properly and is free of leaks. | <input type="checkbox"/> | <input type="checkbox"/> | <input type="checkbox"/> |
| Ensure hydraulic oil breather/vented cap is clean, hydraulic tank cap is tight and vent is open. | <input type="checkbox"/> | <input type="checkbox"/> | <input type="checkbox"/> |
| POWER and DRIVE SYSTEM | P | F | C |
| Ensure battery fluid level is correct (if applicable). | <input type="checkbox"/> | <input type="checkbox"/> | <input type="checkbox"/> |
| Visually inspect motors to ensure there is no damage. | <input type="checkbox"/> | <input type="checkbox"/> | <input type="checkbox"/> |
| Ensure battery charger scrolls through diagnostics when plugged in. | <input type="checkbox"/> | <input type="checkbox"/> | <input type="checkbox"/> |
| Ensure all electrical connections are tight, free of frays and corrosion. | <input type="checkbox"/> | <input type="checkbox"/> | <input type="checkbox"/> |
| Ensure battery meets weight and voltage requirements. | <input type="checkbox"/> | <input type="checkbox"/> | <input type="checkbox"/> |
| Ensure drive, load and caster wheels are properly installed, secure and do not have excessive wear. | <input type="checkbox"/> | <input type="checkbox"/> | <input type="checkbox"/> |
| Ensure all five wheels have contact with the floor. | <input type="checkbox"/> | <input type="checkbox"/> | <input type="checkbox"/> |
| Ensure the electronic brake operates properly. | <input type="checkbox"/> | <input type="checkbox"/> | <input type="checkbox"/> |
| GENERAL | P | F | C |
| Ensure paint is in good condition and that there are not any issues with the overall appearance of the task support vehicle. | <input type="checkbox"/> | <input type="checkbox"/> | <input type="checkbox"/> |
| Inspect overall structural condition including welds. | <input type="checkbox"/> | <input type="checkbox"/> | <input type="checkbox"/> |
| Verify that no unauthorized modifications or additions have been made. | <input type="checkbox"/> | <input type="checkbox"/> | <input type="checkbox"/> |
| Grease and lubricate the mast channel per maintenance manual. | <input type="checkbox"/> | <input type="checkbox"/> | <input type="checkbox"/> |
| Ensure stability pads at base of unit (adjacent to caster wheels) are intact, properly secured and have not sustained any damage | <input type="checkbox"/> | <input type="checkbox"/> | <input type="checkbox"/> |
| Ensure optional equipment such as anchor point, tether, full body harness and tow hitch are in good condition and fully functional (if applicable). | <input type="checkbox"/> | <input type="checkbox"/> | <input type="checkbox"/> |
| Inspect front and rear load trays for functionality and damage. | <input type="checkbox"/> | <input type="checkbox"/> | <input type="checkbox"/> |
| MANUALS - DECALS - DATA PLATE | P | F | C |
| Ensure ANSI/ SIA A92.6 manual of responsibilities, operations manual and service manual are in weather resistant pouch on vehicle. | <input type="checkbox"/> | <input type="checkbox"/> | <input type="checkbox"/> |
| Ensure data plate is in place, secured and legible | <input type="checkbox"/> | <input type="checkbox"/> | <input type="checkbox"/> |
| Ensure all instruction and safety decals are installed, secure and legible. | <input type="checkbox"/> | <input type="checkbox"/> | <input type="checkbox"/> |
| ADDITIONAL COMMENTS | | | |
| | | | |

The undersigned certifies that this machine has been inspected, per each area of inspection, and any and all discrepancies have been brought to the attention of the Owner / User, and that all discrepancies have been corrected prior to any further use of this machine.

| | | |
|------------------|---------------------|-------------|
| OWNER / USER | OWNER / USER | |
| SIGNATURE: _____ | PRINTED NAME: _____ | DATE: _____ |
| DEALER | DEALER | |
| SIGNATURE: _____ | PRINTED NAME: _____ | DATE: _____ |

NOTES

SECTION 3 TROUBLESHOOTING

3-1. GENERAL

Use [Table 3-1](#) as a guide to determine possible causes of trouble. The table is divided into five main categories: Vehicle and Hydraulic System Will Not

Operate: Vehicle Does Not Operate Forward or Reverse: Trouble With Braking: Trouble With Lifting Or Lowering, and Miscellaneous malfunctions.

Table 3-1 Troubleshooting Chart

| MALFUNCTION | PROBABLE CAUSE | CORRECTIVE ACTION |
|---|--|---|
| <p>TRAVEL AND HYDRAULIC SYSTEM WILL NOT OPERATE</p> | <ul style="list-style-type: none"> a. Battery connector not connected. b. Keyswitch "OFF" or defective. c. Safety guard rail open. d. Emergency power disconnect switch pressed or defective. e. "Deadman" footswitch not pressed or defective. f. Battery charge too low. g. Faulty fuse. | <ul style="list-style-type: none"> Check the battery connector and connect if necessary. Turn keyswitch "ON" or bypass keyswitch to determine if it is malfunctioning. Close safety guard rail. Disengage the emergency power disconnect switch or bypass switch to determine if it is malfunctioning. Press "deadman" footswitch or bypass pedal to determine if it is malfunctioning. Check battery charge, charge battery if necessary. Test fuses. |
| <p>VEHICLE DOES NOT OPERATE FORWARD OR REVERSE</p> <p>Vehicle does not travel forward or reverse. All other functions operate normally.</p> <p>Vehicle travels forward but not in reverse.</p> <p>Vehicle travels reverse but not in forward.</p> <p>Vehicle travels forward and in reverse at lower speeds; will not travel at high speed.</p> | <ul style="list-style-type: none"> a. Check all wiring. A loose connection may be the cause of malfunction. c. Defective controller. d. Defective travel switch. Defective travel switch. Defective travel switch. a. Defective travel switch in control head. b. Operator platform raised above 47 inches. | <ul style="list-style-type: none"> Tighten all loose connections before further troubleshooting. Check for proper operation and replace if necessary. Check and replace switch if defective. Check and replace switch if defective. Check and replace switch if defective. Check and replace switch if defective. Lower operator platform below 47 inches. |

Table 3-1 Troubleshooting Chart - Continued

| MALFUNCTION | PROBABLE CAUSE | CORRECTIVE ACTION |
|---|---|--|
| <p>TROUBLE WITH LIFTING OR LOWERING</p> <p>Oil sprays or flows from the top of the lift cylinder.</p> <p>Squealing sounds when lifting Operator's platform.</p> <p>Forks do not lift to top.</p> <p>Weak, slow or uneven action of hydraulic system.</p> <p>Platform does not lift, pump motor does not run.</p> | <p>Defective packing in lift cylinder</p> <p>a. Oil level too low.</p> <p>b. Dry channels in mast.</p> <p>c. Defective mast or Platform rollers</p> <p>a. Oil level too low.</p> <p>b. Load larger than capacity.</p> <p>a. Defective pump or relief valve.</p> <p>b. Worn lift cylinder.</p> <p>c. Load larger than capacity.</p> <p>d. Defective lift motor relay.</p> <p>e. Battery charge low.</p> <p>a. Battery is dead or disconnected.</p> <p>b. Defective wiring.</p> <p>c. Defect in electrical system for operating pump motor.</p> | <p>Repair lift cylinder.</p> <p>Identify oil leak and fill reservoir.</p> <p>Apply grease.</p> <p>Replace rollers.</p> <p>Add oil to reservoir.</p> <p>Refer to I.D.plate for capacity.</p> <p>Check pressure. Adjust as necessary.</p> <p>Replace cylinder.</p> <p>Refer to I.D.platefor capacity.</p> <p>Replace relay on pump motor.</p> <p>Charge battery.</p> <p>Check and recharge if required.</p> <p>Check and repair as required.</p> <p>Check lift switch in control head, as well as the relay.</p> |
| <p>Platform does not lift, motor runs.</p> <p>Platform lifts, but will not go down.</p> <p>Load will not hold</p> <p>Platform does not lift to top. Pump motor runs.</p> | <p>Defect in hydraulic system.</p> <p>Defect in hydraulic system</p> <p>a. Oil bypassing internally in control valve</p> <p>b. Worn lift cylinder or packing.</p> <p>a. Oil level too low.</p> <p>b. Load larger than capacity.</p> <p>c. Batteries need charging.</p> | <p>Check the oil level in the reservoir and the oil lines to the lift cylinder, and repair as required. If normal, check the hydraulic pump, and relief valve. Repair, or adjust.</p> <p>Check lowering control switch and lowering solenoid. Replace as required.</p> <p>Replace valve assembly.</p> <p>Repack cylinder.</p> <p>Add oil to reservoir.</p> <p>Refer to nameplate on side of mast for maximum load capacity.</p> <p>Charge batteries.</p> |

Table 3-1 Troubleshooting Chart - Continued

| MALFUNCTION | PROBABLE CAUSE | CORRECTIVE ACTION |
|--|---|---|
| <p>TROUBLE WITH LIFTING OR LOWERING - Continued</p> <p>Forks drifts down under load when in a raised position.</p> | <p>Leak in hydraulic system, lift cylinder or lowering valve.</p> | <p>Check for leaking fitting in hydraulic line and repair as required. Repack lift cylinder or replace valve assembly.</p> |
| <p>TROUBLE WITH STEERING</p> | <ul style="list-style-type: none"> a. Faulty fuse. b. Check all wiring. A loose connection may be the cause of malfunction. c. Defective potentiometer. d. Defective controller. e. Defective steer motor. | <p>Test fuses.</p> <p>Tighten all loose connections before further troubleshooting.</p> <p>Check and replace potentiometer if defective.</p> <p>Check for proper operation and replace if necessary.</p> <p>Replace if necessary.</p> |

3-2. CONTROLLER TROUBLESHOOTING

3-2.1. Zapi Handset

A Zapi Handset is available that is designed specifically for use with the Zapi controller. It serves multiple functions of reading diagnostic data, testing truck operation, setting options, adjustments and parameter changes of the controller. The Zapi Handset is available through your Big Lift LLC dealer. If you require dealer location information, contact Big Lift LLC.

Remove the rubber plug from the CNC connector of the controller [Figure 3-1](#) and plug in the Zapi Handset connector.

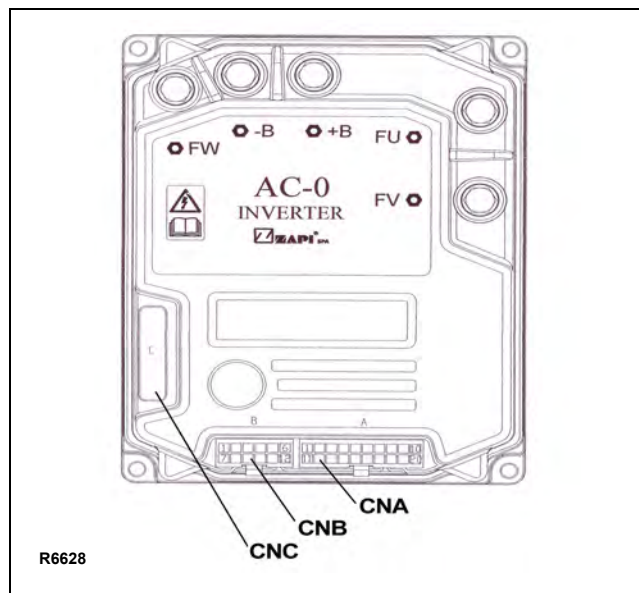

Figure 3-1 Zapi Controller

3-2.2. Fault Detection.

3-2.2.1. General

The microprocessor in the controller records the last five Alarms that have occurred. Items remembered relative to each Alarm are:

- The alarm code
- The times that each alarm occurs consecutively
- The Hour Meter value when the latest event of every alarm occurred

This function permits a deeper diagnosis of problems as the recent history can be revisited.

3-2.2.2. Logbook Access

To view the alarm logbook proceed as follows:

1. Connect the Zapi Handset, refer to paragraph [3-2.1](#).
2. Press the ENTER button (3, [Figure 3-2](#)) to enter the MAIN MENU.
3. Press the ROLL down button (2) or the ROLL up button (1) until ALARMS menu appears on the display.
4. Press the ENTER button (3) to enter the ALARMS menu.
5. Press the ROLL up button (1) to view the alarms. Pressing the ROLL down button (2) returns to the most recent alarm.

If an alarm has not occurred, the display will show NONE.

6. Press the OUT button (4) to exit the alarms.

The display will ask: "CLEAR LOGBOOK?" Press the ENTER button (3) for Yes or OUT button (4) for No.

7. Press the OUT button (4) again to return to Opening Zapi Menu.

3-2.3. Testing Truck Operation.

The Zapi Handset can be used to test certain truck operations as follows:

1. Connect the Zapi Handset, refer to paragraph [3-2.1](#).
2. Press the ENTER button (3, [Figure 3-2](#)) to enter the MAIN MENU.
3. Press the ROLL down button (2) or the ROLL up button (1) to find the TESTER display.
4. Press the ENTER button (3) to enter the TESTER function.

The first switch to be tested is shown on the display.

5. To verify various switch functions, press the ROLL down button (2) or the ROLL up button (1) to locate the switch on the display and then operate that function to verify operation
6. Press the OUT button (6) to exit the tests. The display will show TESTER.
7. Press the OUT button (6) again to return to Opening Zapi Menu.

3-2.4. Factory Settings

Parameter setting are not to be changed from factory settings without explicit written permission from Big Lift LLC. To verify the parameter settings proceed as follows and refer to [Table 3-2](#):

1. Connect the Zapi Handset, refer to paragraph [3-2.1](#).
2. Press the ENTER button (3, [Figure 3-2](#)) to enter the MAIN MENU.
3. Press the ROLL down button (1) or the ROLL up button (2) to find the PARAMETER CHANGE display.
4. Press the ENTER button (3) to view the parameters.

5. Press the ROLL down button (2) or the ROLL up button (1) to find the parameter to be checked.
6. Press the SET up button (5) or the SET down button (6) until the factory setting is reached.
7. Press the OUT button (4) to exit the parameters. The confirmation request appears.
8. Press ENTER button (3) to accept the changes or press OUT button (6) to refuse the changes.
9. Press the OUT button (6) again to return to Opening Zapi Menu.

Table 3-2 Parameter Adjustments

| Parameter | Factory Setting |
|------------------------|-----------------|
| ACCELER. DELAY | LEVEL = 4 |
| RELEASE BRAKING | LEVEL = 5 |
| INVERS. BRAKING | LEVEL = 7 |
| PEDAL BRAKING | LEVEL = 9 |
| SPEED LIMIT BRK | LEVEL = 2 |
| BRAKE CUTBACK | LEVEL = 5 |
| MAX SPEED FORW | 107 Hz |
| MAX SPEED BACK | 107 Hz |
| CUTBACK SPEED | 70% |
| CUTBACK SPEED 2 | 50% |
| CUTBACK SPEED 3 | 20% |
| CURVE CUTBACK | 60% |
| DEADMAN BRAKING | 7 |
| HS (hard-soft) CUTBACK | 100% |
| FREQUENCY CREEP | 1.20 Hz |
| MAXIMUM CURRENT | 9 |
| INCHING SPEED | 0 Hz |
| INCHING TIME | 0% |
| AUXILIARY TIME | 0.4 |

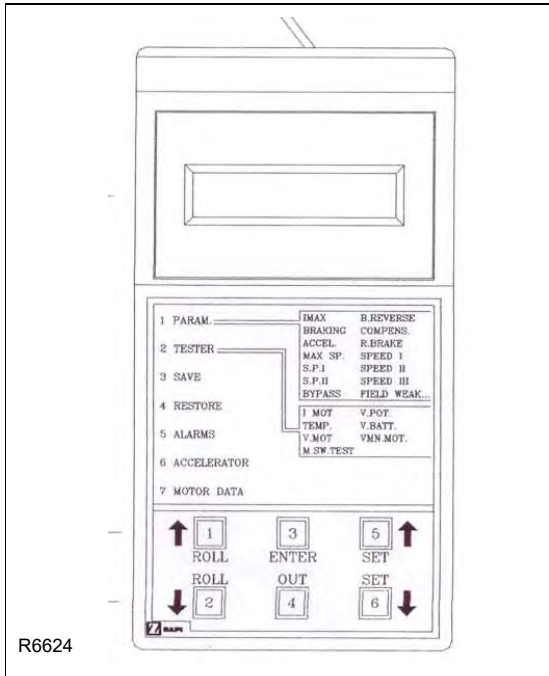

Figure 3-2 Zapi Handset

Table 3-3 Troubleshooting Chart (Traction/Lift Controller)

| ERROR | ERROR TEXT | POSSIBLE CAUSE | FAULT CLEARANCE |
|--------------|-------------------|---|--|
| 1 | WRONG CONFIG | This alarm occurs the first time a controller is switched on when the non volatile eeprom memory is not initialized yet. Then it is necessary to specify if the controller is AC-0 or AC-1 type (see AC TYPE 0 in the hidden hardware setting Zapi menu). If the alarm is present, by switching off the key the AC TYPE 0 setting will be automatically turned On (and the controller is specified to be an AC-0). The AC TYPE 0 setting can be changed only when a WRONG CONFIG alarm is present. If it is not present, it is necessary to clear the eeprom memory if the WRONG CONFIG alarm occurs. | The AC TYPE 0 setting must be factory adjusted and so the alarm should never happen. So ask for the assistance of a Big Lift LLC Service Representative when this alarm occurs. |
| 8 | WATCH DOG | This alarm occurs when the embedded WATCH DOG protection is not able to either cut off the power stage when not triggered or it is not able to activate the power stage when triggered. | Verify the motor is connected and there is continuity of the three motor phases. If the alarm occurs permanently, replace the controller. |
| 16 | AUX OUPUT KO | This alarm occurs when the feedforward PWM generated by the controller to supply the Electromechanical Brake are not matched in between. The diagnosis is made only when the Tiller Switch is active. | Replace the controller because the driver of the Electromechanical Brake has a failure. |
| 13 | EEPROM KO | This alarm occurs due to a HW or SW defect of the non-volatile embedded memory supporting the controller regulations. | Try to execute a CLEAR EEPROM operation. This consists of entering ALARMS in the MAIN MENU. Push at the same time the two right side buttons to enter the hidden ZAPI MENU. Roll up and down until the CLEAR EEPROM appears on the handset display. Push the Enter Button two times. Switch the key off and on to check the result. If the alarm occurs permanently, replace the controller. |
| 17 | LOGIC FAILURE #3 | This alarm occurs when the circuit to limit via HW the current peak in the controller is active. | If is probably a power failure or a logic failure. If the alarm occurs permanently, replace the controller. |
| 18 | LOGIC FAILURE #2 | This alarm occurs when the circuit, to compensate for the dead times of the sine waves, is failed. | Replace the Controller. |

Table 3-3 Troubleshooting Chart (Traction/Lift Controller) - Continued

| ERROR | ERROR TEXT | POSSIBLE CAUSE | FAULT CLEARANCE |
|--------------|-------------------|---|--|
| 19 | LOGIC FAILURE #1 | This alarm signals that an overvoltage/ undervoltage protection operation has occurred. | Normally the overvoltage occurs due to the regenerative braking energy increasing the battery voltage; the under voltage of the logic supply, can be due to a depletion in the key voltage. First, check for the failure mode. Then contact the Big Lift LLC Service Representative to look for a countermeasure. This alarm may occur for a HW failure. Replace the Controller. |
| 30 | VMN LOW | Before the main contactor is turned on, the SW turns on the top side Power Mosfets and expects the phase V voltage to increase toward the rail capacitor value. If the phase V does not increase, this alarm occurs. The alarm may occur when the initial diagnosis is overcome, and the main contractor is expected to be closed. Then when the operator tries to move the vehicle, but the +Batt terminal of the controller is lower voltage than the Battery voltage, this alarm occurs (Main Contractor has lost the contact although it is closed). | If the problem occurs before the Main Contactor closes, a power failure occurred (e.g. a bottom side Power Mosfet short circuited or a top side Power Mosfet is broken) or a Logic Failure occurred in the controller. If the problem occurs when the operator turns a moving vehicle, the problem is the Battery positive is not connected to the +Batt terminal of the controller (check the continuity of the main contactor). If the problem occurs permanently, replace the controller. |
| 31 | VMN HIGH | Before the main contactor is turned on, the SW turns on the bottom side Power Mosfets and expects the phase V voltage to fall to GND value. If the phase V remains high, this alarm occurs. | There are two possibilities: 1. A motor phase is not connected to the controller or broken. 2. A Power Failure (e.g. a Bottom side Power Mosfet opened) or a Logic Failure occurred in the controller. In this case, replace the controller. |
| 37 | CONTACTOR CLOSED | The controller check if the MV contact is closed when the coil isn't driven, trying to discharge the capacitor bank. If they don't discharge, the fault condition is entered. | It is suggested to check the contactor, if it is mechanically stuck or burnt closed. |
| 38 | CINTACTOR OPEN | The main contactor coil has been driven by the logic board, but the contactor does not close. | There are two possibilities: 1. The wires to the coil are interrupted or not well connected. 2. The contact of the contactor is defective. |

Table 3-3 Troubleshooting Chart (Traction/Lift Controller) - Continued

| ERROR | ERROR TEXT | POSSIBLE CAUSE | FAULT CLEARANCE |
|-------|--------------------|--|---|
| 49 | I=0 EVER | This test is carried out when the motor is running, and it verifies that the current feedback sensor is not constantly stuck at 0. | If everything is OK for the motor, the problem could be in the related circuit. |
| 55 | PROGRAM LIFT LEVER | <p>The SW continuously matches the potentiometer connected to CNA#18 with the Main Lifting/Lowering pair request (CNB# and CNB#8). When the vehicle TYPE is set 2, the alarm occur in the following conditions:</p> <ol style="list-style-type: none"> 1. If both the Main Lifting and Main Lowering request are disactive and the potentiometer voltage is higher than 60 mV over either the MIN LIFT or the MIN LOWER setting. 2. If the Main Lifting request is active and the potentiometer voltage is higher than 200 mV over the MAX LIFT setting. 3. If the Main Lowering request is active and the potentiometer voltage is higher than 200 mV over the MAX LOWER setting. 4. If the MIN LIFT setting is higher than the MAX LIFT setting. <p>When the vehicle TYPE is set at 3, the alarm occurs in the following conditions:</p> <ol style="list-style-type: none"> 1. If the Main Lowering request is higher that the MIN LOWER. 2. If the MIN LOWER setting is higher that the MAX LOWER | Check the Main Lifting/Lowering pair (CNB#8 and CNB#9) and the voltage on the potentiometer connected to CNA#18. (Use the readings LIFTING SWITCH, DESCENT SWITCH and LIFTING CONTROL in the TESTER to facilitate the troubleshooting). |
| 53 | STBY I HIGH | This diagnosis is executed only when the main contactor is opened and asked to be closed (e.g. at key on or when the main contactor is opened and a new motion request turn active). Then the outputs of the Current amplifiers must be in a narrow window close to 2.5 Vdc (from 2.26 V to 2.74 V). Otherwise this STBY I HIGH alarm occurs. | If the alarm occurs permanently, replace the controller. |

Table 3-3 Troubleshooting Chart (Traction/Lift Controller) - Continued

| ERROR | ERROR TEXT | POSSIBLE CAUSE | FAULT CLEARANCE |
|--------------|-------------------|--|---|
| 60 | CAPACITOR CHARGE | In working condition, a resistance connected between the key and the Rail Capacitors, keeps the Rail Capacitors charged before the Main Contactor closes. When the voltage on the Rail Capacitors (measured on the phase V) is low and does not increase when the main contactor is opened, this alarm occurs. | The possibilities: <ol style="list-style-type: none"> 1. Another device, connected in parallel with the Rail Capacitors, has a failure. 2. At least one motor phase is not connected to the controller or broken. 3. A Power failure or a Logic Failure occurred in the controller. Replace the controller. |
| 61 | HIGH TEMPERATURE | This alarm occurs when the temperature of the base plate is higher than 78°C up to 100°C. At 100°C the current is limited to 0 Amps. | Improve the air cooling of the controller. |
| 65 | MOTOR TEMPERAT | This is just a warning with not effect will the vehicle performance. It occurs when the temperature of the motor winding overtakes the MOTOR OVER-TEMP setting. | Check the thermal sensor inside the motor (use the MOTOR TEMPERATURE reading in the TESTER menu). If the sensor is OK, improve the air cooling of the motor. |
| 67 | CAN BUS KO | This alarm occurs if the controller does not receive any message from the CAN Bus line. | <ol style="list-style-type: none"> 1. First check the wiring. 2. If OK, try to disconnect one to one the module connected to the CAN Bus and check if this alarm disappears. 3. Replace the controller. |
| 70 | ENCODER ERROR | Two consecutive readings of the encoder speed are too drastic. It is not possible for the encoder to change its speed a lot in a short period. An encoder failure has occurred (e.g. one or two channels of the encoder are corrupted or disconnected). | Check both the electric and the mechanical encoder functionality. Frequently one of the two sensor bearing rings slips inside its seat causing this alarm. Also, the electronic noise on the sensor bearing can be a cause of the alarm. |
| 71 | HANDBRAKE | This alarm occurs when the operator tries to travel with the emergency brake active. | Check the emergency brake switch and its wiring to CNA#13 The emergency brake switch must be connected between CAN#13 and GND. When it is closed to GND, the emergency brake is considered active. A failure in the logic is possible too. Replace the controller. |
| 73 | THERMIC SENS KO | When the output of the thermal sensor on the base plate is higher than 4.95V or lower than 0.1V, the sensor is assumed defective and this alarm occurs. | It is necessary to replace the controller. |

Table 3-3 Troubleshooting Chart (Traction/Lift Controller) - Continued

| ERROR | ERROR TEXT | POSSIBLE CAUSE | FAULT CLEARANCE |
|--------------|-------------------|--|---|
| 74 | DRIVER SHORTED | This alarm occurs when the voltage on the main contactor is higher than expected. This means that the main contactor coil has a high voltage although it is not supplied. | Replace the controller. |
| 75 | CONTACTOR DRIVER | This alarm occurs when the voltage on the main contactor is smaller than expected. The main contactor has a null voltage when supplied. | Check coils of the main contactor (CNA#1) is not short circuited. If not, replace the controller. |
| 76 | COIL SHORTED | This alarm occurs when there is an overload on one of the following connections: CNA#1, CNA#3, CNA#4 or CNA#6. Typically the problem is due to a short circuit of one of the coils connected to these outputs. After the overload has been removed, the alarm automatically resets by releasing and then enabling a travel demand. | Check the coils of main contactor (CNA#1), electromechanical brake (CNA#3), pump contactor (CNA#4), and aux valve (CNA#6). |
| 78 | VACC NOT OK | A test is made at key-on and after 20 sec that both the travel demands are disactive. This alarm occurs if the ACCELERATOR reading in the TESTER menu is higher than 1.0V (meaning the wiper of the potentiometer is higher than 2Vdc). | Check the mechanical calibration and the functionality of the potentiometer. |
| 80 | FORW+BACK | This alarm occurs when both the travel demands (Fwd and Bwd) are active at the same time. | Check the wiring of the Fwd and Bwd travel demand inputs (use the readings in the TESTER to facilitate the troubleshooting). A failure in the logic is possible too. When you verified the travel demand switches are working properly and the wiring is right, replace the controller. |
| 79 | INNCORECT START | This is just a warning for an incorrect starting sequence. | The possible reasons for this alarm are (use the readings in the TESTER to facilitate the troubleshooting): <ol style="list-style-type: none"> 1. A travel demand active at key on 2. The tiller switch active at key on 3. The H&S input active at key on 4. The Quick inversion active at key on <p>A failure in the logic is possible too. When all of the above conditions checked OK, replace the controller.</p> |

Table 3-3 Troubleshooting Chart (Traction/Lift Controller) - Continued

| ERROR | ERROR TEXT | POSSIBLE CAUSE | FAULT CLEARANCE |
|--------------|-------------------|---|---|
| 86 | PEDAL WIRE KO | The SW continuously checks for the connection of the two supply ends of the potentiometer in the accelerator. The test consists of the voltage drop on a sense diode, connected between MPOT (CNB#11) and GND and cascaded with the potentiometer: if the potentiometer gets disconnected on PPOT or NPOT, no current flow in this sense diode and the voltage on the MPOT connection collapses down. When the NPOT voltage is less than 0.3V this alarm occurs. This alarm also occurs when the NPOT voltage is higher than 2 VDC (to detect the condition of a broken sense diode). | Check the voltage on NPOT (CNB#11) and the potentiometer connections. |
| 90 | LIFT+LOWER | This alarm occurs when both a lifting request and a lowering request are active at the same time. | If the MDI-PRC is absent, check only the of the main lifting/lowering pair (CNB#8 and CNB#9); if the MDI-PRC is present check the wiring of the aux lift/lowering pair (CNA#14 and CNA#15). (Use the readings in the TESTER to facilitate the troubleshooting). A failure in the logic is also possible. When you have verified the lifting/lowering switches and the wiring is right, replace the controller. |
| 97 | INPUT ERROR #1 | This alarm occurs when the PLD device has a failure. The PLD device is used for both, the Passive Emergency Cell and a Multiplexer on the main lifting/lowering requests. This Multiplexer exists the lifting and the not lifting level on two distinct addresses. When the lifting and the not lifting outputs have the same logic level, the PLD device has failed and this alarm occurs. | Replace the controller. |

Table 3-3 Troubleshooting Chart (Traction/Lift Controller) - Continued

| ERROR | ERROR TEXT | POSSIBLE CAUSE | FAULT CLEARANCE |
|--------------|-------------------|---|--|
| 91 | LIFT LOW ACTIVE | This is just a warning when a lifting/lowering request is active at key-on. | <p>The possible reasons for this alarm are (use the readings in the TESTER to facilitate the troubleshooting):</p> <ul style="list-style-type: none"> • When MDI-PRC is absent: at least one between LIFTING SWITCH (CNB#9) or DESCENT SWITCH (CNB#8) active at key on. • When vehicle TYPE is Level=1: at least one between: LIFTING SWITCH (CNB#9) or DESCENT SWITCH (CNB#8), DIGITAL INPUT#1 (CNA#14) or DIGITAL INPUT#2 (CNA#15) active at key on. • When vehicle TYPE is Level=2: at least one between: LIFTING SWITCH (CNB#9) or DESCENT SWITCH (CNB#8) active at key on. • When vehicle TYPE is Level=3: at least one between LIFTING SWITCH (CNB#9) or DECENT SWITCH (CNB#8) active at key-on. <p>A failure in the logic is possible too. When all of the above conditions were checked and nothing was found, replace the controller.</p> |
| 93 | WRONG SET BAT. | When the key is turned ON, the controller checks the battery voltage and verifies it is within a window around the nominal value. | Replace the battery. |
| 94 | CURRENT SENS KO | This alarm occurs when the procedure for the maximum current set-up is in progress. | The maximum current set-up is factory adjusted and so this alarm should never happen. So ask for the assistance of a Big Lift LLC Service Representative when this alarm occurs. |
| 99 | CHECK UP NEEDED | This is just a warning to perform programmed maintenance. | It is just enough to turn the CHECK UP DONE option to level ON after the maintenance is executed. |

Table 3-4 Troubleshooting Chart (EPS-AC0 Controller)

| ERROR | ERROR TEXT | POSSIBLE CAUSE | FAULT CLEARANCE |
|--------------|-------------------|--|---|
| 6 | SERIAL ERR #1 | Main uC and Slave uC communicate via a local serial interface. This alarm occurs when the slave uC does not receive the communication from the main uC through the serial interface. | Replace the controller. |
| 13 | EEPROM KO | This occurs if a test to write and read one location in EEPROM fails. The SW expects to read the written value. It can also occur when the hour counter gives different values between the three redundant location in which it is recorded. It also occurs when the busy bit of the EEPROM does not rise within 12 msec. | Replace the controller. |
| 16 | LOGIC FAILUREE #4 | This alarm occurs in the rest state if the output of the voltage amplifier of the phase Vw-Vv have a drift larger than ± 0.25 V. | Replace the controller. |
| 17 | LOGIC FAILURE #3 | This alarm occurs in the rest state if the output of the voltage amplifier of phase Vu-Vw have a drift larger than ± 0.25 V. | Replace the controller. |
| 18 | LOGIC FAILURE #2 | This alarm occurs when the real voltage between phases X and V of the motor is different from the desired. | Replace the controller. |
| 19 | LOGIC FAILURE #1 | This alarm occurs when the real voltage between phases W and U of the motor is different from the desired. | Replace the controller. |
| 32 | VMN NOT OK | This alarm occurs in the initial rest state after key on if the output of the motor voltage amplifiers are not in the window from 2.2 to 2.8 Vdc. | Replace the controller. |
| 48 | MAIN CONT. OPEN | This alarm occurs only when the setting CAN BUS is PRESENT. Then the EPS-AC0 waits for a via CAN information that the traction controller has closed the main contactor. If this information lacks more than 1.5 secs, this alarm occurs. | Find, on the traction controller, the reason for keeping the main contactor open. |
| 53 | STBY I HIGH | This alarm occurs two ways: <ol style="list-style-type: none"> 1. In the initial rest state after key on, if the outputs of the current amplifiers are not comprised in the window 2.2 to 2.8 Vdc. 2. After the initial diagnosis this alarm occurs when the output of the current amplifiers at rest have a drift larger than ± 0.15 V. | Replace the controller. |

Table 3-4 Troubleshooting Chart (EPS-AC0 Controller) - Continued

| ERROR | ERROR TEXT | POSSIBLE CAUSE | FAULT CLEARANCE |
|--------------|-------------------|--|---|
| 61 | HIGH TEMPERATURE | This alarm occurs if the temperature of the controller base plate overtakes 75 degrees. | Improve the cooling of the controller; otherwise replace the controller. |
| 65 | MOTOR TEMPERATURE | This alarm occurs only when DIAG MOTOR TEMP is on and the thermal sensor inside the motor measures a temperature higher than 150 degrees. It also occurs when trying to acquire the motor resistance with a temperature in the motor higher than 150 degrees (still with DIAG MOTOR TEMP to ON). | 3. Check that the thermal sensor in the motor is working correctly. If it is, improve the cooling of the motor. |
| 70 | HIGH CURRENT | This alarm occurs if the circuit to limit via hardware the current in the motor is either always active at key on or repeatedly active when the motor is turning. | Check that the motor is suited to work with the EPS-AC0 (not oversized). Otherwise, replace the controller. |
| 71 | POWER FAILURE #3 | This alarm occurs when the current in the phase V of the motor is zero and the motor is commanded for moving. | Check that the power fuse is OK. Check the battery positive arrives to the controller. Check the continuity of the wire in the [phase V of the motor. Otherwise replace the controller. |
| 72 | POWER FAILURE #2 | This alarm occurs when the current in the phase U of the motor is zero and the motor is commanded for moving. | Check that the power is OK. Check the battery positive arrives to the controller. Check the continuity of the wire in the phase U of the motor. Otherwise replace the controller. |
| 73 | POWER FAILURE #1 | This alarm occurs when the current in the phase W of the motor is zero and the motor is commanded for moving. | Check that the power is OK. Check the battery positive arrives to the controller. Check the continuity of the wire in the phase W of the motor. Otherwise replace the controller. |
| 83 | BAD ENCODER SIGN | This alarm occurs in applications with toggle switches when the applied frequency (FREQUENCY) and the motor speed (ENC SPEED) have opposite sign. | Swap in between the two encoder channels (CNB#7 with CNB#8). |
| 84 | STEER SENSOR KO | This alarm occurs if the command potentiometer (CPOC1 on CNA#9 or CPOC2 on CNA#8) changes with a jerk larger than MAX SP SLOPE. This alarm is used to catch a discontinuity in the voltages of the command potentiometer. | Change the twin pot. |
| 85 | STEER HAZARD | This is just a warning to inform that the steering controller is limiting the angle in the steering direction. No speed reduction occurs on the traction | |

Table 3-4 Troubleshooting Chart (EPS-AC0 Controller) - Continued

| ERROR | ERROR TEXT | POSSIBLE CAUSE | FAULT CLEARANCE |
|--------------|---------------------|---|---|
| 218 | CLOCK PAL NOT OK | The main uC send an analog signal towards the slave uC to reset the slave uC on demand. When the slave uC detects this analog signal external to a window from 2.2 to 2.8 and not in the range to generate the reset on demand, the slave uC raises this alarm. | Replace the controller. |
| 99 | INPUT ERROR #1 | This alarm occurs when the voltage on CNA#4 (lower potential terminal of the safety contacts) is higher than 12V. | When the safety contacts are open, the voltage on CNA#4 is expected to be close to 0 Vdc. Only a harness mistake may connect NK1 to a higher than 12 V. |
| 212 | MICRO SLAVE #8 | This alarm occurs when the encoder counting of the main uC is not matched with the encoder counting of the slave uC. | Replace the controller. |
| 219 | STEPPER MOTORE MISM | This alarm occurs if the frequency and the amplitude of the voltages from the stepper motor lines are mismatched. In normal condition when the amplitude of the stepper motor lines increase, the frequency of the stepper motor lines must increase too. | Replace the controller. |
| 220 | MOTOR LOCKED | This alarm occurs if the current in the steer motor stays close to the maximum current longer than 1 sec. | Search for a mechanical problem locking the motor. To make easier fault detecting, set DEBUG OUTPUT to level 11. |
| 221 | MICRO SLAVE #4 | This alarm occurs in one of the following: (Open loop application only) If the slave uC detects the stator voltage phasor rotates in the opposite direction respect to the sign of the stepper motor speed. (Closed loop application only) if the slave uC detects the stator voltage phasor rotates in the opposite direction respect to the commanded position. | Replace the controller. |

Table 3-4 Troubleshooting Chart (EPS-AC0 Controller) - Continued

| ERROR | ERROR TEXT | POSSIBLE CAUSE | FAULT CLEARANCE |
|--------------|-------------------|--|--|
| 222 | FB POT LOCKED | <p>In application with a feedback potentiometer, this alarm occurs if the feedback potentiometer (CPOT on CNB#6) does not change (or changes in the opposite direction) its value even if commanded to change.</p> <p>In application with toggle switches with ENCODER CONTROL to off, this alarm occurs if the feedback encoder counting does not change its value even if commanded to change.</p> | <p>In application with the feedback with the feedback potentiometer, verify the feedback potentiometer is not mechanically loosened.</p> <p>Check there is not a mechanical block of the steered wheel. Be sure the wiper has not reached its own electrical limit because of too much angle of the steered wheel. Besides, this alarm may occur at the installation when the motor rotates in the wrong direction from the command.</p> |
| 223 | JERKING FB POT | This alarm occur if the feedback potentiometer (CPOT on CNB#6) changes with a jerk larger than 0.3 V in 16 msec. This alarm is used to catch a discontinuity in the voltages of the feedback potentiometer. | Change the feedback potentiometer. |
| 225 | CURRENT GAIN | This alarm occurs when the parameters to compensate for the gain of the current amplifiers (ADJUSTMENT #03 and ADJUSTMENT #04) have the default values. | Replace the controller. |
| 226 | NO SYNC | Every 16 msec, inside the code cycle, the main uC rises and then lowers an input for the slave uC (SYNC). When the slave uC detects no edge for more than 100 msec on this input, this alarm occurs. This is just a watch dog function: when the main uC does not execute the code cycle it does not update the SYNC signal and the slave uC cuts off the steer and traction. | Replace the controller. |
| 227 | SLAVE COM. ERROR | Main uC and Slave uC communicate via a local serial interface. This alarm occurs when the main uC does not receive the communication from the slave uC through this serial interface. | Replace the controller. |
| 237 | WAITING DATA | This warning occurs only if CAN BUS is PRESENT. At the eps-ac0 asks to the traction controller to send a list of parameters via CAN Bus. From the request until the parameters are correctly relieved, this warning occurs. The steer is not activated yet, and the safety relays remain open when this warning is present. | |

Table 3-4 Troubleshooting Chart (EPS-AC0 Controller) - Continued

| ERROR | ERROR TEXT | POSSIBLE CAUSE | FAULT CLEARANCE |
|--------------|-------------------|---|--|
| 228 | POSITION ERROR | This alarm occurs for an error in the redundant test o the feedback sensors. | Check the potentiometer connected to CNB#6 is working correctly. If toggle switches are connected to CNA#2 and CNA#3, verify that they are working correctly and setting AUX FUNCTION 11 is correct. Also the sensor bearing in the motor (encoder). The sensor bearing has two rings: one connected to the rotor safety; the other is connected to the motor frame. Check these two rings are strictly connected to their structure without slip. |
| 238 | EPS NOT ALIGNED | This is a real alarm that cuts off the traction. It occurs at the initial alignment if the straight-ahead condition is not matched within 6 sec. Throughout this 6 secs delay, the steer is not activated yet, the safety relays are open and the traction is stopped. | |
| 239 | WAITING FOR TRAC | At key-on the eps-ac0 needs an assent from the traction controller to close the safety contacts and to turn on operational mode. Until this assent is not relieved, this warning occurs. The steer is not activated yet and the safety relays remain open when this warning is present. | |
| 241 | ENCODER ERROR | It occur when ENCODER CONTROL is set ON and the real frequency does not pursuit the commanded frequency. | This condition occurs several times due to either, a mismatch between the Encoder resolution used in the SW and the real encoder resolution, or a wrong connection between th4e two encoder channels. In this latest case exchange in between the two encoder channels. |
| 242 | Q LINE SENSOR KO | This alarm occurs when the mean voltage on the Quadrature line of the stepper motor (connection CNA#8) is not null: the voltage on every stepper motor line is a sine wave with null mean voltage. | Check continuity of the stepper motor connections. In particular the resistance between CNA#8 and the minus battery (with the stepper motor at rest) is expected to be very low (close to 30 ohms). |
| 243 | D LINE SENSOR KO | This alarm occurs when the mean voltage on the Direct line of the stepper motor (connection CNA#9) is not null: the voltage on every stepper motor line is a sine wave with null mean voltage. | Check continuity of the stepper motor connections. In particular the resistance between CNA#9 and the minus battery (with the stepper motor at rest) is expected to be very low (close to 30 ohms) |

| | | | |
|-----|------------------|---|---|
| 245 | DATA ACQUISITION | This alarm occurs when acquiring the motor resistance or when adjusting the parameters to compensate for the gain of the current amplifiers (maximum current factory adjusted). | Recycle the key. |
| 244 | GAIN EEPROM KO | The parameter to compensate for the gain of the current amplifiers (ADJUSTMENT #03 and ADJUSTMENT #4) are recorded in a non-volatile memory (eeprom) with a redundant handling. In fact every adjustment is recorded in three eeprom locations. If the values in these three locations are different, this alarm occurs. | Replace the controller. |
| 246 | MICRO SLAVE KO | In stepper motor application, this alarm occurs if the main uC is detecting a direction of the stepper motor not matched with the one that the slave uC is detecting. In the closed loop application, this alarm occurs if the main uC is detecting a direction of the steering error not matched with the one that the slave uC is detecting. Furthermore, this alarm occurs if the main uC is detecting no steering limitation while the slave uC is detecting a steering limitation. | Replace the controller. |
| 247 | CAN BUS KO | This alarm occurs only when the setting CAN BUS is PRESENT. Then the eps-ac0 must receive the event messages from the traction controller. If these messages lack more than about 1 sec, this alarm occurs. | Check the CAN Bus communication system and analyze the frames from the traction controller to the steer controllers. |
| 248 | S.P OUT OF RANGE | This alarm occurs for a fault on the command potentiometer (CPOC1 on CNA#9, CPOC2 on CNA#8). When a single command pot is chosen, the alarm occurs if its wiper (CPOC1) range is from 0.8 Vdc to 4.2 Vdc. When the twin pot is chosen, the alarm occurs if the sum of the two wiper voltages (CPOC1+CPOC2) range is from 4.5 Vdc to 5.5 Vdc. | Check the connections of the potentiometer. This alarm occurs when one connection of the command potentiometer is broken. |
| 249 | F.B OUT OF RANGE | This alarm occurs for a fault on the feedback potentiometer (CPOT on CNB#6). It occurs if CPOT exits the range of 0.3 Vdc to 4.7 Vdc. | Check the connections of the feedback potentiometer. This alarm occurs when one connection of the feedback potentiometer is broken. |

| | | | |
|-----|-------------|--|---|
| 250 | MICRO SLAVE | It occurs when the information on the status bus between the main uC and the slave uC is frozen to the 0xFF value (the slave uC does not update the status bus configuration). | Replace the controller. |
| 251 | KM OPEN | This alarm occurs if the slave uC detects the safety contact, of the main uC, is open when expected to be closed. | Replace the controller. |
| 252 | KS OPEN | This alarm occurs if the main uC detects the safety contact, of the slave uC, is open when expected to be closed. | Replace the controller. |
| 253 | KM CLOSED | This alarm occurs at key on if the slave uC detects the safety contact, of the main uC, is closed prior to being commanded. | This alarm occurs if the connection CNA#5 (K1) is around a voltage of 12 Vdc when switching on the key. In fact, when the safety contacts are open, K1 is expected to be connected to a battery voltage (not 12 V). Search for a harness problem or replace the controller. |
| 254 | KS CLOSED | This alarm occurs if the main uC detects the safety contact, of the slave uC to be closed prior to being commanded. | This alarm occurs if the connection CNA#4 (NK1) is around a voltage of 12 Vdc when switching on the key. In fact, when the safety contacts are open to a minus battery voltage (not 12 V). Search for a harness problem or replace the controller. |

NOTES

SECTION 4 STEERING SYSTEM

4-1. CONTROL ARM

4-1.1. Steering Control Removal.

1. Engage the emergency power disconnect switch and turn off key switch.
2. Remove the six screws from the lower cover. Separate lower cover and upper cover.

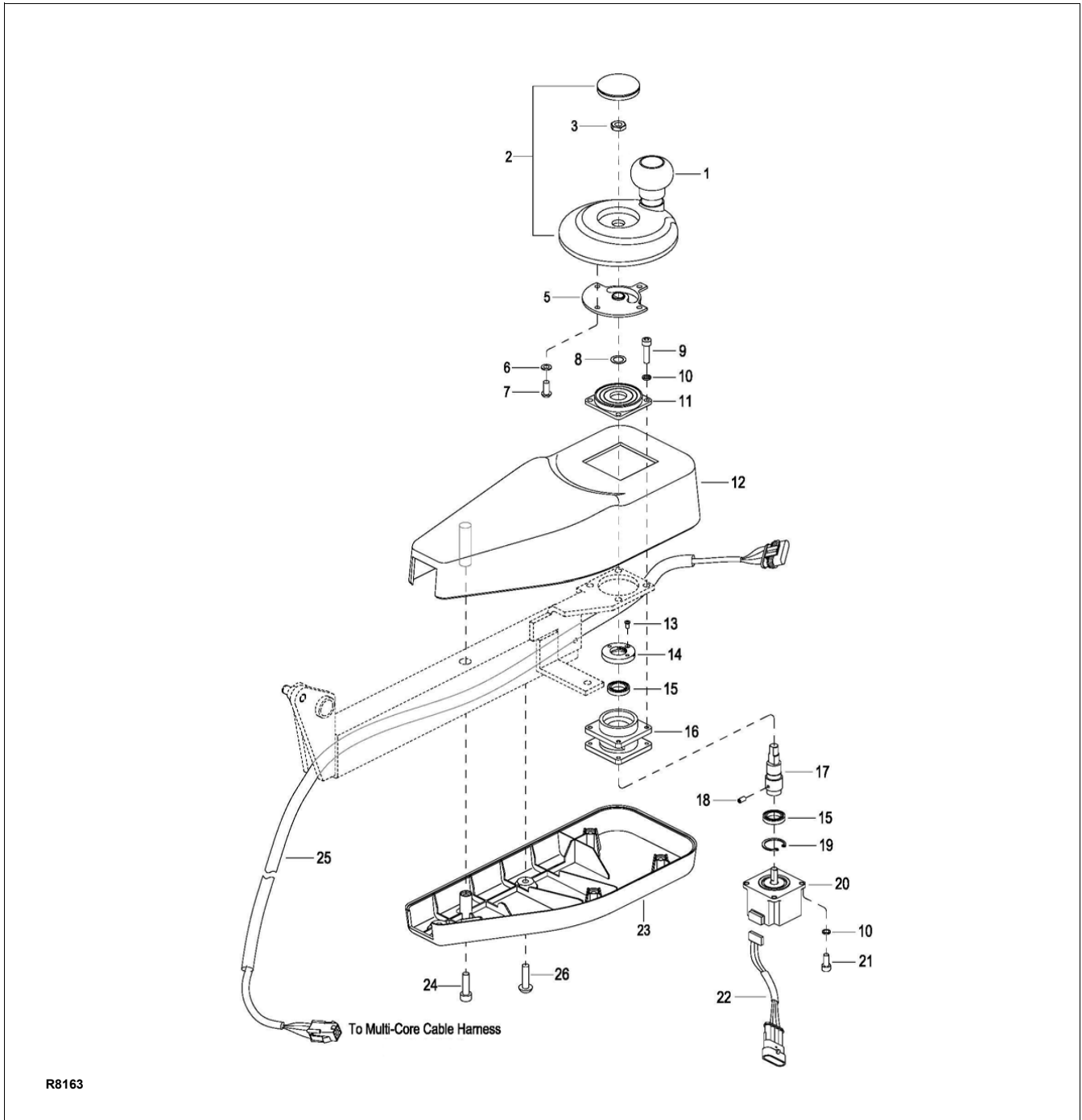

Figure 4-1 Control Arm (Left)

3. Disconnect the two harnesses from each other and from the potentiometer.
4. Remove button plug, nut, lock washer, handle and shims.
5. Remove four screws, four lock washers and bracket from handle.
6. Remove the four screws, four lock washers that holds the damper.
7. Remove potentiometer from control arm.
8. Remove screw, nut and upper bearing.
9. Remove four screws, four lock washers and remove potentiometer from bearing block.
10. Loosen screw and remove shaft from potentiometer.
11. Remove snap ring and lower bearing from shaft.

4-1.2. Steering Control Installation.

1. Install lower bearing and snap ring on shaft.
2. Install shaft on potentiometer and secure with screw.
3. Position potentiometer on bearing block and secure with four screws, and four lock washers.
4. Install upper bearing, nut and screw.
5. Position potentiometer on control arm.
6. Install damper and secure with four screws and four lock washers.
7. Install bracket on handle and secure with four screws and four lock washers.
8. Install shims and handle, engaging bracket with damper.
9. Secure handle with nut and lock washer and install the button plug.
10. Reconnect harness to harness and potentiometer.
11. Install lower cover and upper cover and secure with four screws six screws.
12. Disengage the emergency power disconnect switch and turn on key switch.

4-2. COMPARTMENT COVER

4-2.1. Cover Removal.

1. Engage the emergency power disconnect switch and turn off key switch.
2. Remove two screws.
3. Carefully lift cover up and off the truck.

4-2.2. Cover Installation.

1. Carefully position cover on the truck.
2. Install two screws (1).
3. Disengage the emergency power disconnect switch and turn on key switch.

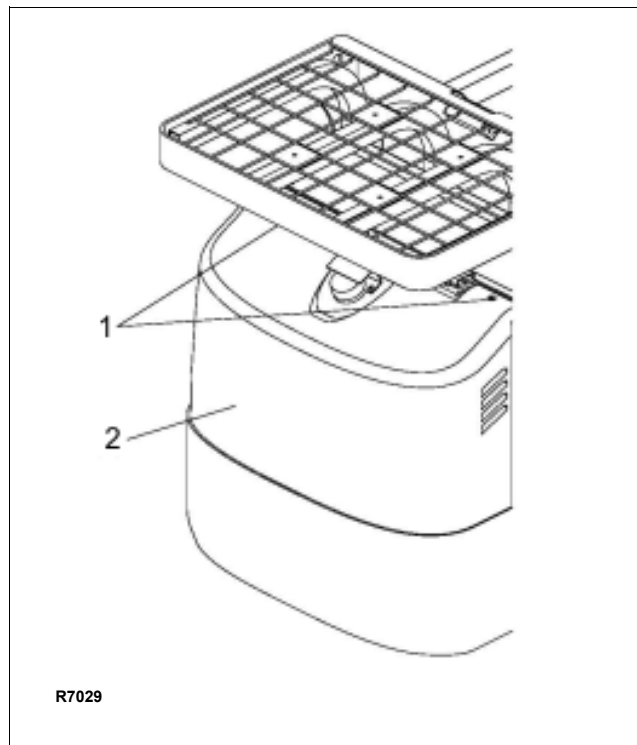

Figure 4-2 Compartment Cover

4-3. STEER MOTOR

4-3.1. Motor Removal.

1. Engage the emergency power disconnect switch and turn off key switch.
2. Remove the compartment cover as described in paragraph 4-2.1.

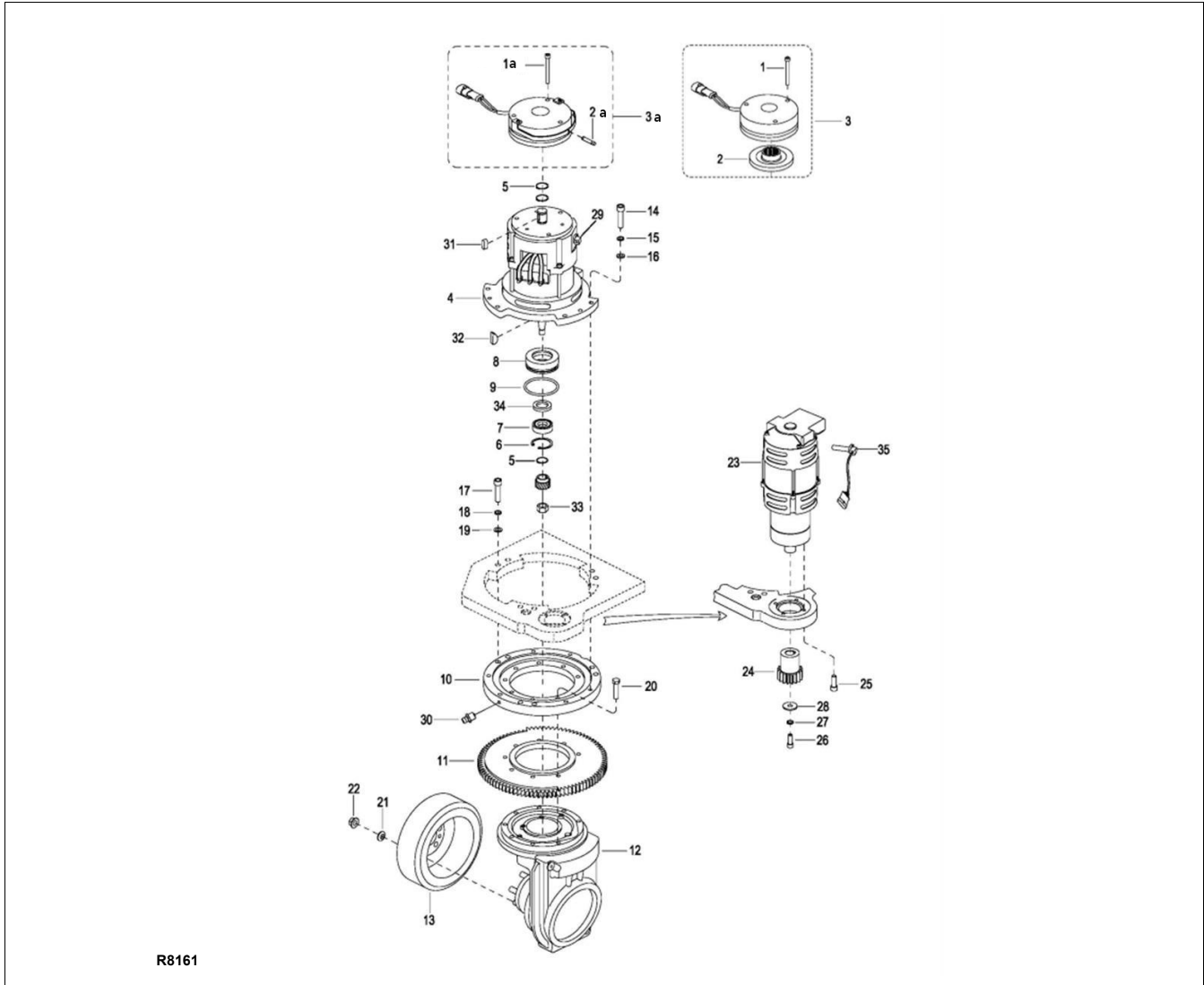

Figure 4-3 Drive System

3. Disconnect harness and cables from the steer motor.
 4. Remove three screws three lock washers and three flat washers from under the vehicle.
 5. Remove the steering motor from the top of the vehicle.
- 4-3.2. Motor Installation.**
1. Position the steering motor in the top of the motor compartment.
 2. Secure the motor with two screws two lock washers and two flat washers from under the vehicle.
 3. Reconnect harness and cables to the steering motor.
 4. Install the compartment cover as described in paragraph 4-2.2.
 5. Disengage the emergency power disconnect switch and turn on key switch.

NOTES

SECTION 5 BRAKE SERVICING

5-1. BRAKES.

The brake system consists of a drive motor mounted brake. This brake is spring applied and electrically released.

5-1.1. Brake Assembly Replacement

1. Engage the emergency power disconnect switch and turn off key switch.
2. Block load wheels.
3. Remove the compartment cover as described in paragraph [4-2.1](#).
4. Disconnect electric brake from main harness.
5. Remove the mounting screws and brake.
6. Place the new brake into position and secure with the mounting screws.
7. Reconnect electric brake to harness.
8. Remove load wheel blocks and check operation.
9. Disengage the emergency power disconnect switch and turn on key switch.

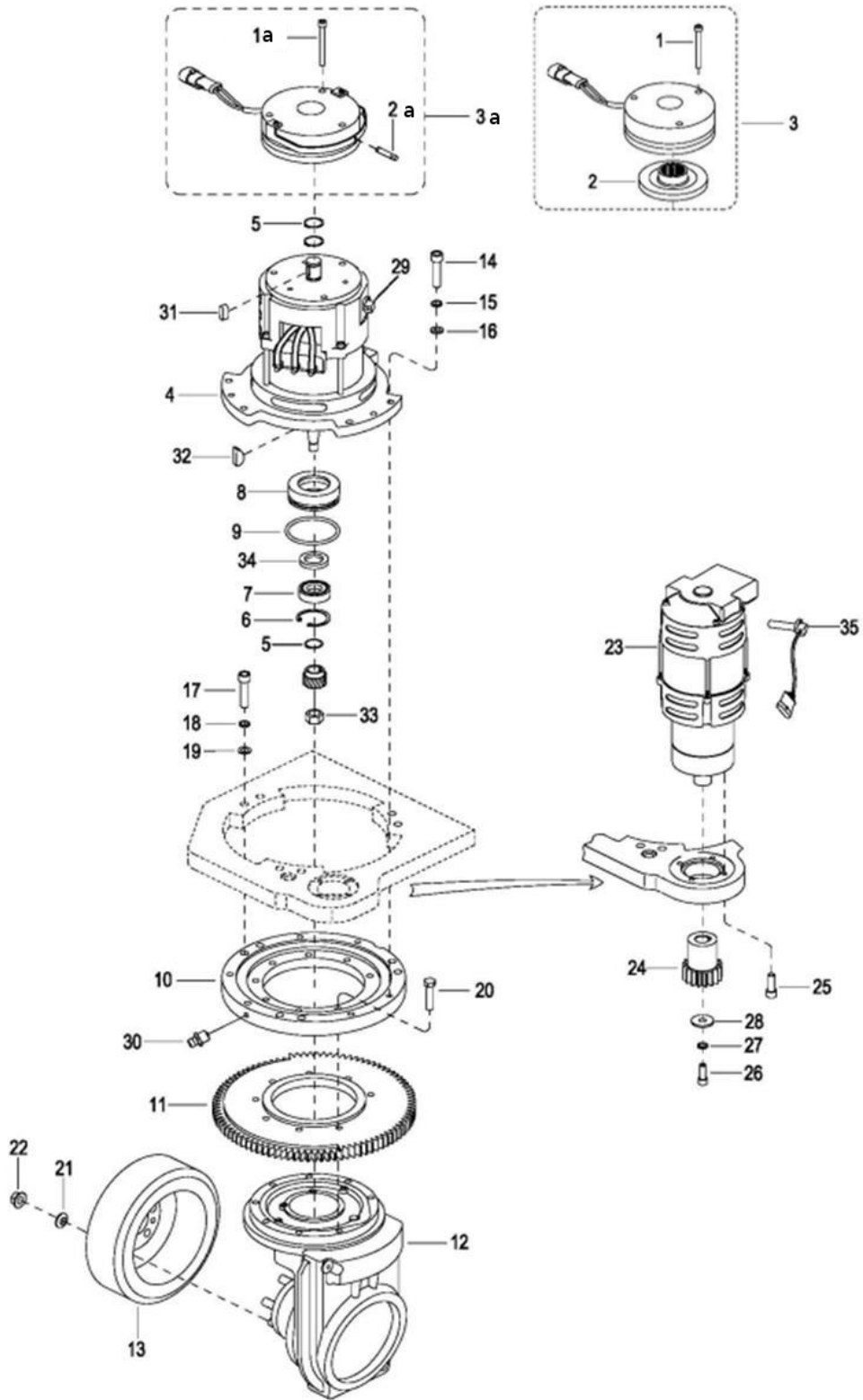

R8161

Figure 5-1 Transmission, Motor & Brake Assembly

SECTION 6 TRANSMISSION, DRIVE WHEEL, LOAD WHEEL, CASTERS

6-1. Transmission and Drive Motor.

1. Engage the emergency power disconnect switch and turn off key switch.
2. Remove the compartment cover as described in paragraph 4-2.1.
3. Remove the steering motor as described in paragraph 4-3.
4. Raise the vehicle off the ground to provide clearance for drive assembly (1, Figure 6-1) out the bottom. Securely block the vehicle to prevent movement.
5. Disconnect electric brake from harness.
6. Disconnect cables from drive motor.
7. Disconnect encoder from drive motor.
8. Support the drive assembly and remove six screws, six washers and flat washers.
9. Lower the drive assembly out the bottom of the vehicle.
10. Install new drive assembly by reversing the steps above.

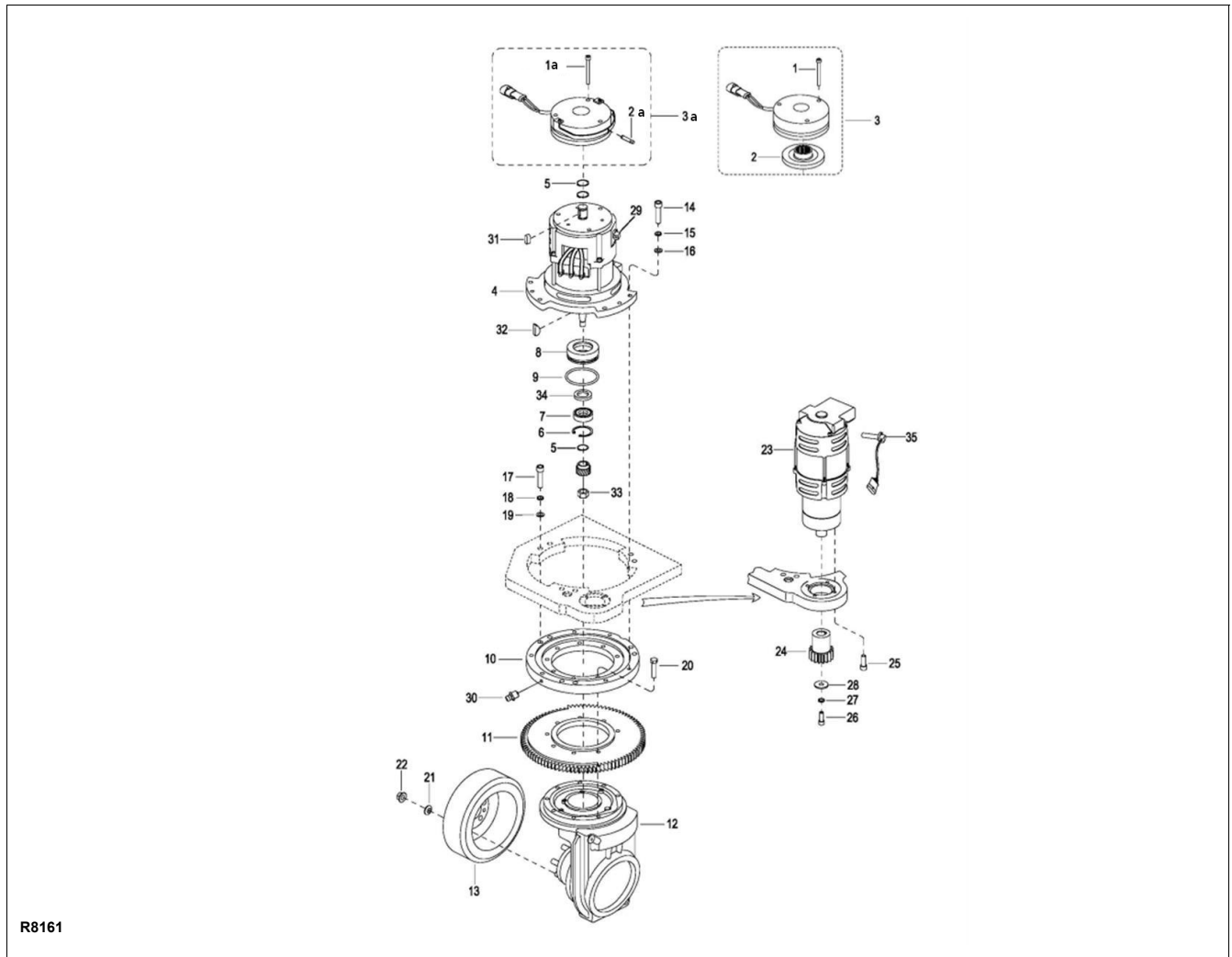

Figure 6-1 Drive System

6-2. Load Wheel.

6-2.1. Removal

1. Engage the emergency power disconnect switch and turn off key switch.
2. Block the drive wheel to prevent the vehicle from rolling.
3. Jack up the vehicle to raise the load wheels off the floor. Securely block the vehicle in the raised position by positioning supports under both fork tips.
4. Remove four screws and cover.
5. Remove nut, washer and load wheel.
6. Remove seal from load wheel.
7. Remove bearings from load wheel.
8. Inspect bearings and replace if necessary.

6-2.2. Installation

1. Pack bearings with grease.
1. Reassemble bearings in wheel.
2. Install seal from load wheel.
3. Position load wheel in the axle and install washer and nut. Tighten nut until there is a slight drag on load wheel. Secure nut with tab on washer.

4. Install cover and secure with four screws.
5. Remove the blocking from under the vehicle and lower it to the ground.
6. Disengage the emergency power disconnect switch and turn on key switch.

6-3. Drive Wheel.

1. Engage the emergency power disconnect switch and turn off key switch.
2. Jack up the vehicle to gain access to the drive wheel; then securely block the vehicle to prevent movement.
3. Remove the five mounting screws and five lock washers.
4. Remove drive wheel.
5. Install new drive wheel in reverse order of removal.

6-4. Caster.

Casters provide additional stability. Installation of the casters is shown in and repair parts are shown in [Figure 11-4](#).

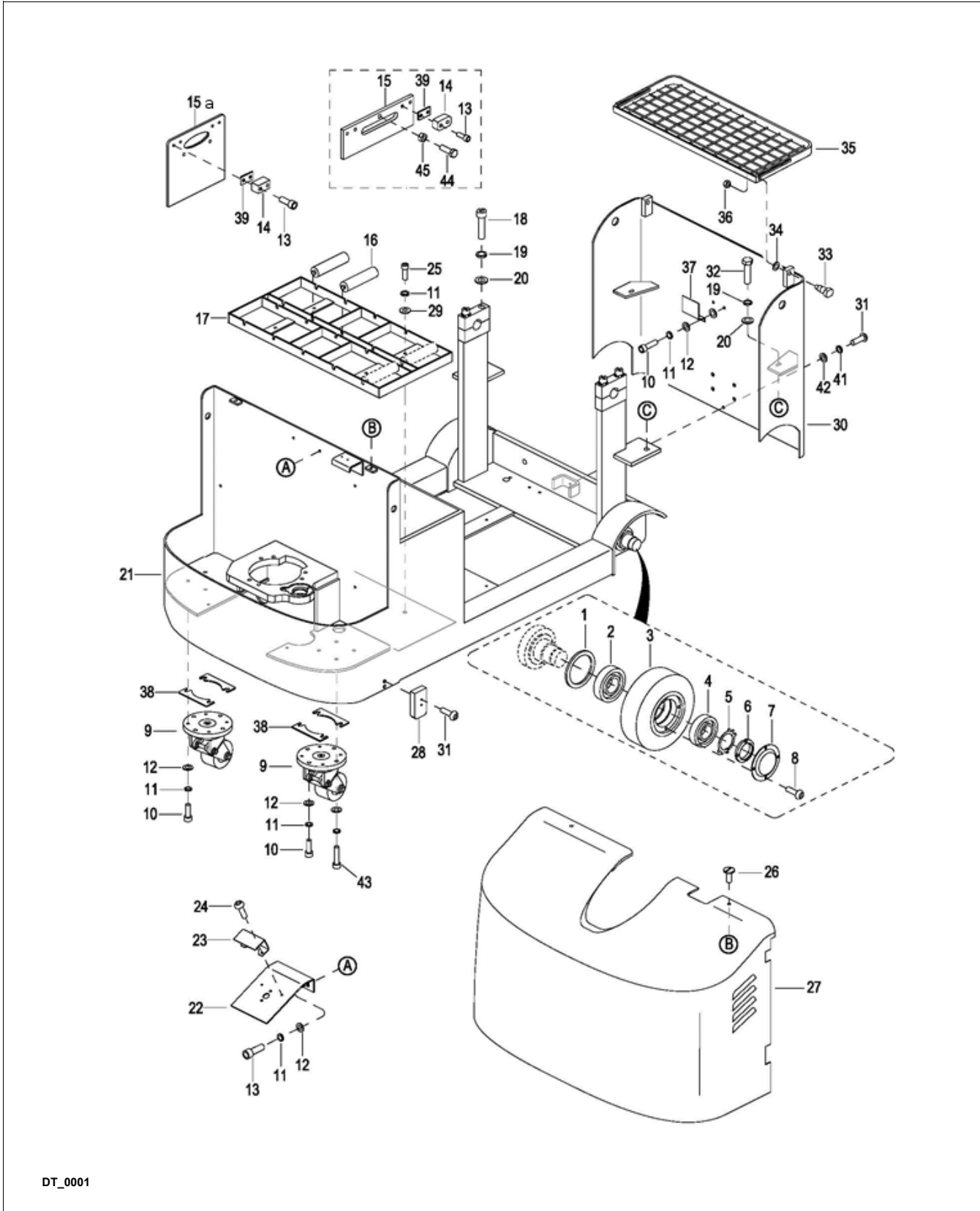

DT_0001

Figure 6-2 Frame

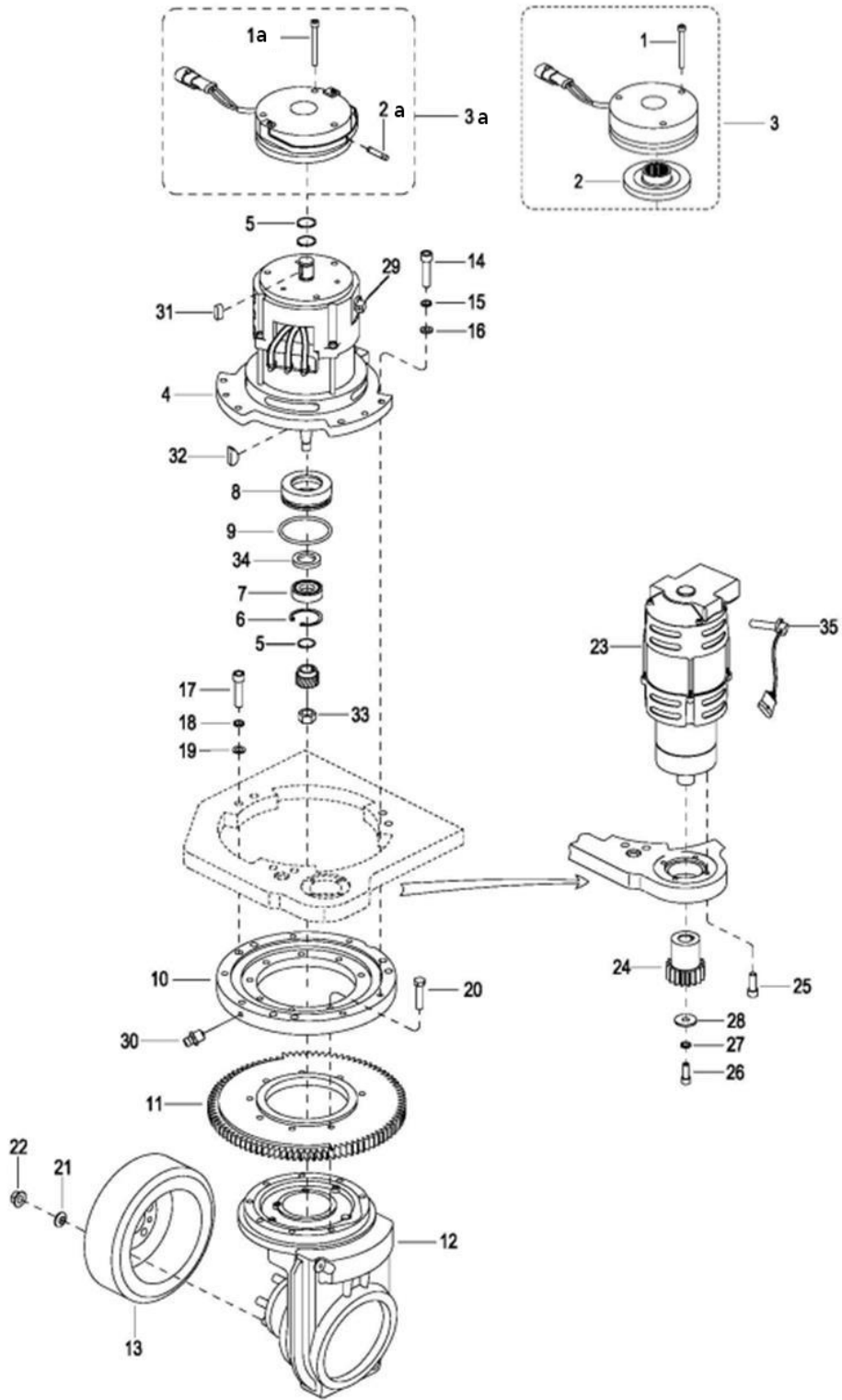

R8161

Figure 6-3 Transmission, Motor & Brake Assembly

SECTION 7 ELEVATION SYSTEM SERVICING

7-1. GENERAL.

The elevation system includes the outer mast, inner mast, lift linkage, drag chains, lift chains, lift cylinder and ram head.

7-2. LIFT CHAIN LENGTH ADJUSTMENT.

1. Fully lower the Platform.
2. Engage the emergency power disconnect switch and turn off key switch.

WARNING: Before attempting any adjustment, make certain power is disconnected.

3. Loosen jam nut to allow for adjustment of middle jam nut.
4. Break the lower jam nut free from the middle jam nut.
5. Take up slack in the lift chain with middle jam nut.
6. Align anchor so the clevis pin is parallel to the mast.

CAUTION: At least 3 full threads must be present below lower nut after adjustment.

7. Tighten jam nuts securely while maintaining alignment of clevis pin.
8. Disengage the emergency power disconnect switch and turn on key switch.
9. Test chain by operating Platform. If slack is still apparent, repeat above procedure.

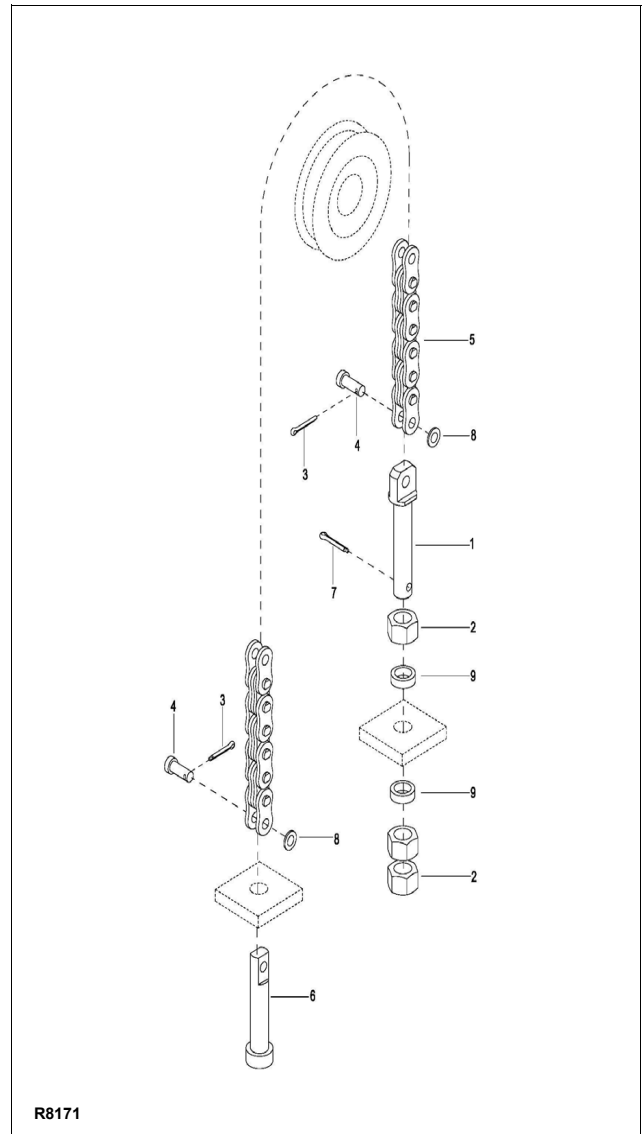

Figure 7-1 Chain Assembly

7-3. LIFT CHAIN WEAR INSPECTION.

The lift chain should be replaced when it is worn enough to increase its length by 3% or more. On Telescopic vehicles, Both chains should be replaced at the same time. To make this determination proceed as follows.

Using a section of chain that sees the most frequent operation over the chain sheaves, isolate a vertical portion under tension from the weight of carriage and forks.

Measure the distance between pin centers on 20 vertical links. If the section measures 12.88" or more, the chain should be replaced.

New chain anchor pins should be installed when chains are replaced. Never replace a partial section of chain and never repair chain. Refer to paragraph 7-4. when installing new chain

7-4. LIFT CHAIN REPLACEMENT.

10. Engage the emergency power disconnect switch and turn off key switch

7-4.1. Three Stage Mast

7-4.1.1.Mast Lifting Chain

1. With the vehicle wheels securely blocked, raise the inner mast approximately three feet and position blocks or strong supports under the inner mast.
2. Lower inner mast onto the support. Check that arrangement is secure before proceeding.
3. Engage the emergency power disconnect switch and turn off key switch.

WARNING: Before attempting any replacement, make certain power is disconnected.

4. Remove cotter pin, flat washer, clevis pin and anchor connecting chain to inner mast.

5. Remove cotter pin, flat washer and clevis pin connecting chain to adjusting screw at the outer mast.
6. Remove chain from sheave.
7. Position new chain on sheave.
8. Secure chain to outer mast with adjusting screw, clevis pin, flat washer and cotter pin.
9. Connect the opposite end of chain to the inner mast with anchor, clevis pin, washer and cotter pin.
10. Adjust the chains according to paragraph 7-2.
11. Disengage the emergency power disconnect switch and turn on key switch.

7-4.1.2.Platform Lifting Chain

1. With the vehicle wheels securely blocked, raise the Platform approximately three feet and position blocks or strong supports under Platform.
2. Lower Platform onto the support. Check that arrangement is secure before proceeding.
3. Engage the emergency power disconnect switch and turn off key switch.

WARNING: Before attempting any replacement, make certain power is disconnected.

4. Remove cotter pin, flat washer, clevis pin and anchor connecting chain to lift cylinder.
5. Remove cotter pin, flat washer and clevis pin connecting chain to adjusting screw at Platform.
6. Remove chain from sheave.
7. Position new chain on sheave.
8. Secure chain to Platform with adjusting screw, clevis pin, flat washer and cotter pin.
9. Connect the opposite end of chain to the lift cylinder with anchor, clevis pin, washer and cotter pin.
10. Adjust the chains according to paragraph 7-2.
11. Disengage the emergency power disconnect switch and turn on key switch.

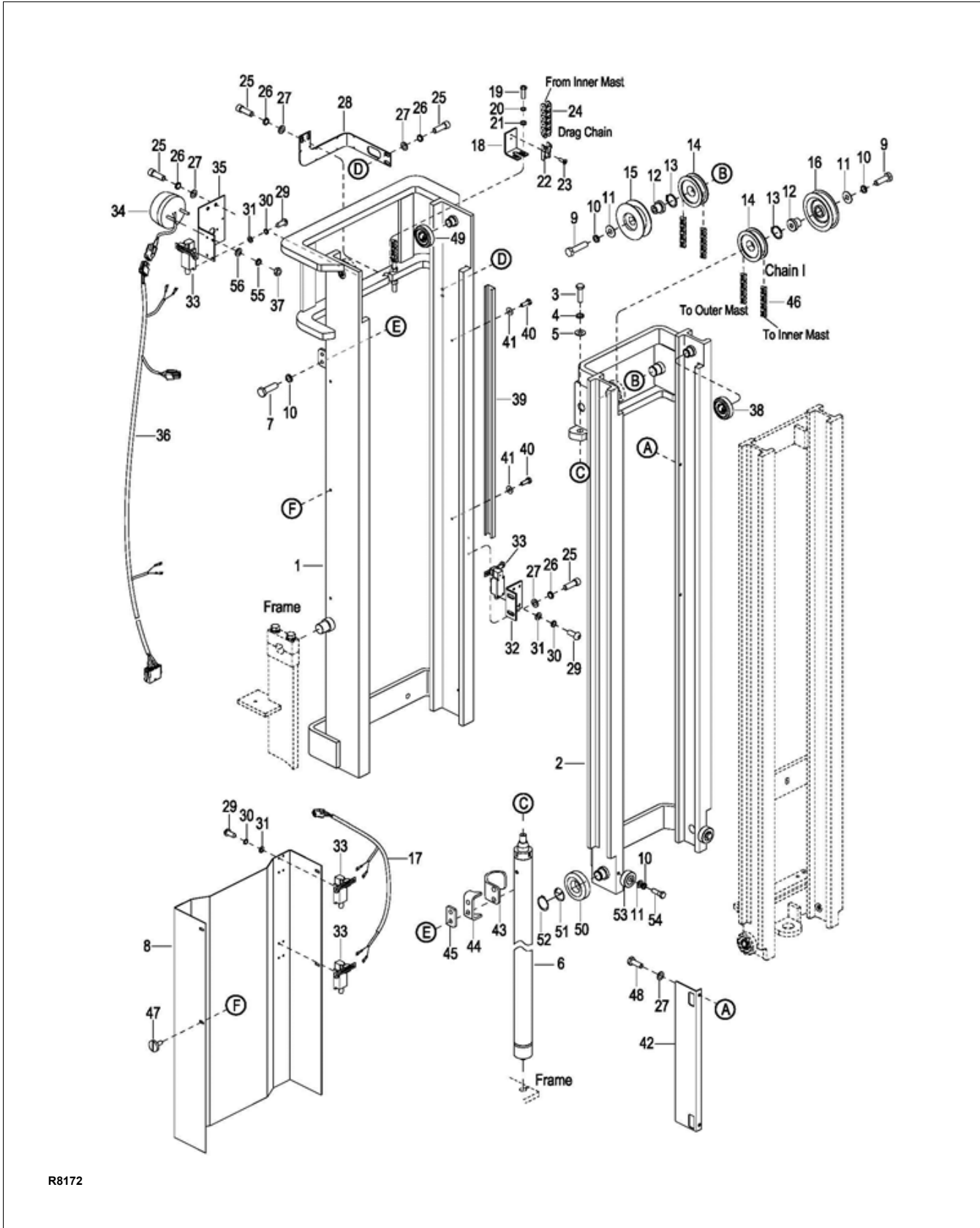

R8172

Figure 7-2 Elevation System - Part 1

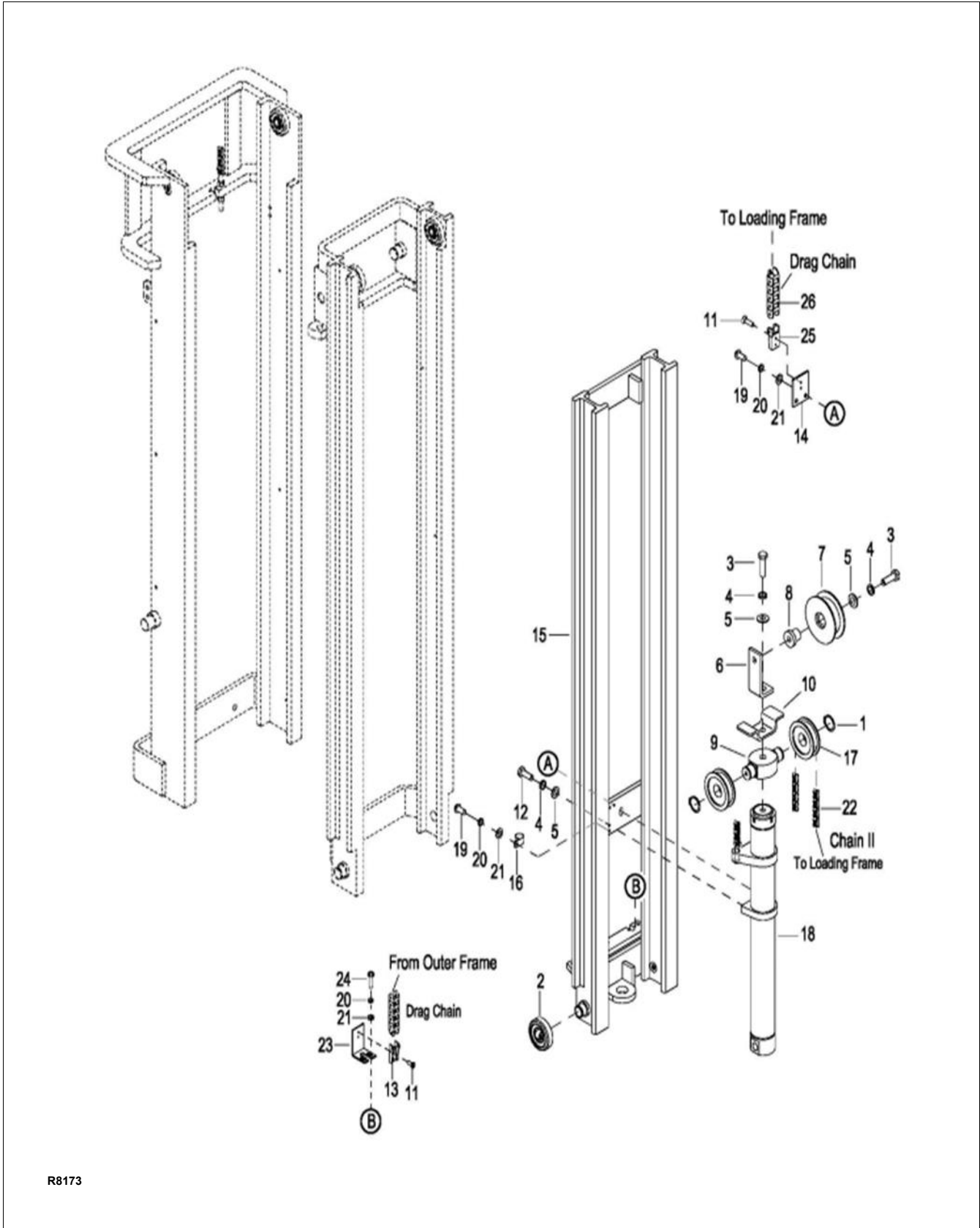

R8173

Figure 7-3 Elevation System - Part 2

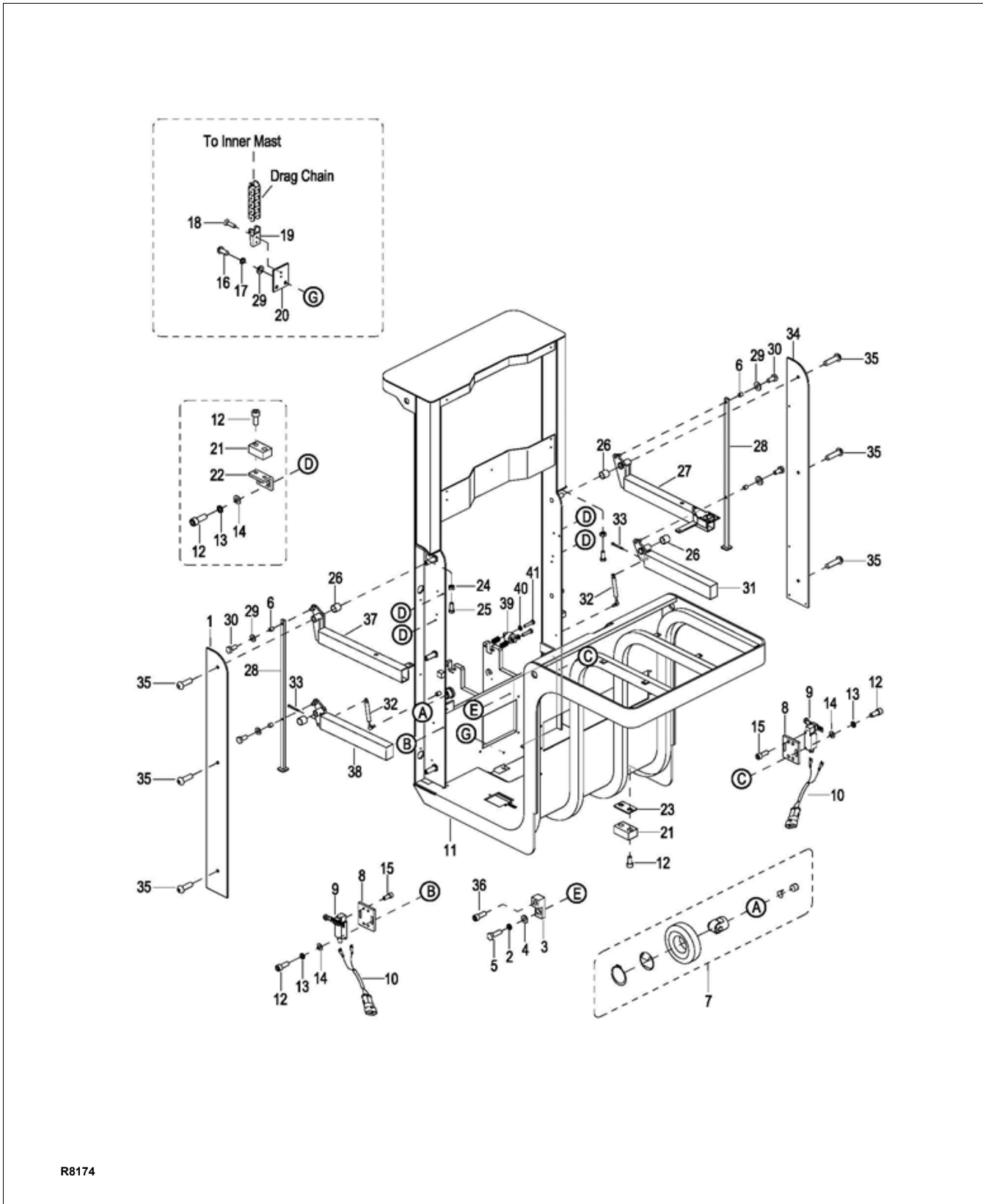

R8174

Figure 7-4 Platform Installation

7-5. LIFT CYLINDERS.

NOTE: Removal and repair of lift cylinders are covered in [SECTION 8](#).

SECTION 8 HYDRAULIC SYSTEM SERVICING

8-1. LINES AND FITTINGS

WARNING: When the platform is raised, pressure exists in the hydraulic system lines and fittings. To ensure release of pressure, platform must be fully lowered and the batteries disconnected before performing any maintenance on the hydraulic system.

NOTE: Leaking hydraulic fittings may be remedied by simply tightening fittings. If this does not remedy the leak, the fittings or line must be replaced.

1. Fully lower the platform.
2. Engage the emergency power disconnect switch and turn off key switch.
3. Remove the compartment cover as described in paragraph 4-2.

CAUTION: Hydraulic oil can damage parts. Wipe off any oil immediately. Provide a container under the line or fitting before disconnecting.

4. **Three Stage Mast vehicles:** Refer to [Figure 8-1](#) and [Figure 8-3](#) and remove leaking line or fitting and replace it with a new line or fitting.
5. Check level of hydraulic oil. If required, add hydraulic oil to bring to proper level. Use hydraulic oil listed in [Table 2-2](#).
6. Disengage the emergency power disconnect switch and turn on key switch.
7. Operate the lift and lower buttons to refill the cylinder and lines with hydraulic oil.
8. Check level of hydraulic oil. If required, add hydraulic oil to bring to proper level. Use hydraulic oil listed in [Table 2-2](#).
9. Install the compartment cover as described in paragraph 4-2.

8-2. HYDRAULIC PUMP, MOTOR, AND RESERVOIR ASSY

The hydraulic pump/motor assembly can be disassembled and repaired. However, a defective pump, valve or motor requires replacement of that component.

WARNING: When the platform is raised, pressure exists in the hydraulic system lines and fittings. To ensure release of pressure, platform must be fully lowered and the batteries disconnected before performing any maintenance on the hydraulic system.

8-2.1. Removal

1. Fully lower the platform.
2. Engage the emergency power disconnect switch and turn off key switch.
3. Remove the compartment cover as described in paragraph 4-2.
4. Tag and disconnect electrical leads from motor and solenoid of pump/motor assembly.

NOTE: The reservoir and tube will be filled with hydraulic oil. Place a container under the pump assembly to catch any hydraulic oil.

5. Disconnect hose from pump/motor assembly.
6. While supporting pump/motor assembly, remove four screws, four lock washers and four flat washers.
7. Remove the pump/motor assembly.

8-2.2. Disassembly and Reassembly

1. Remove the hydraulic pump/motor assembly as described in paragraph 8-2.1.
2. Refer to [Figure 11-8](#) for disassembly and reassembly.

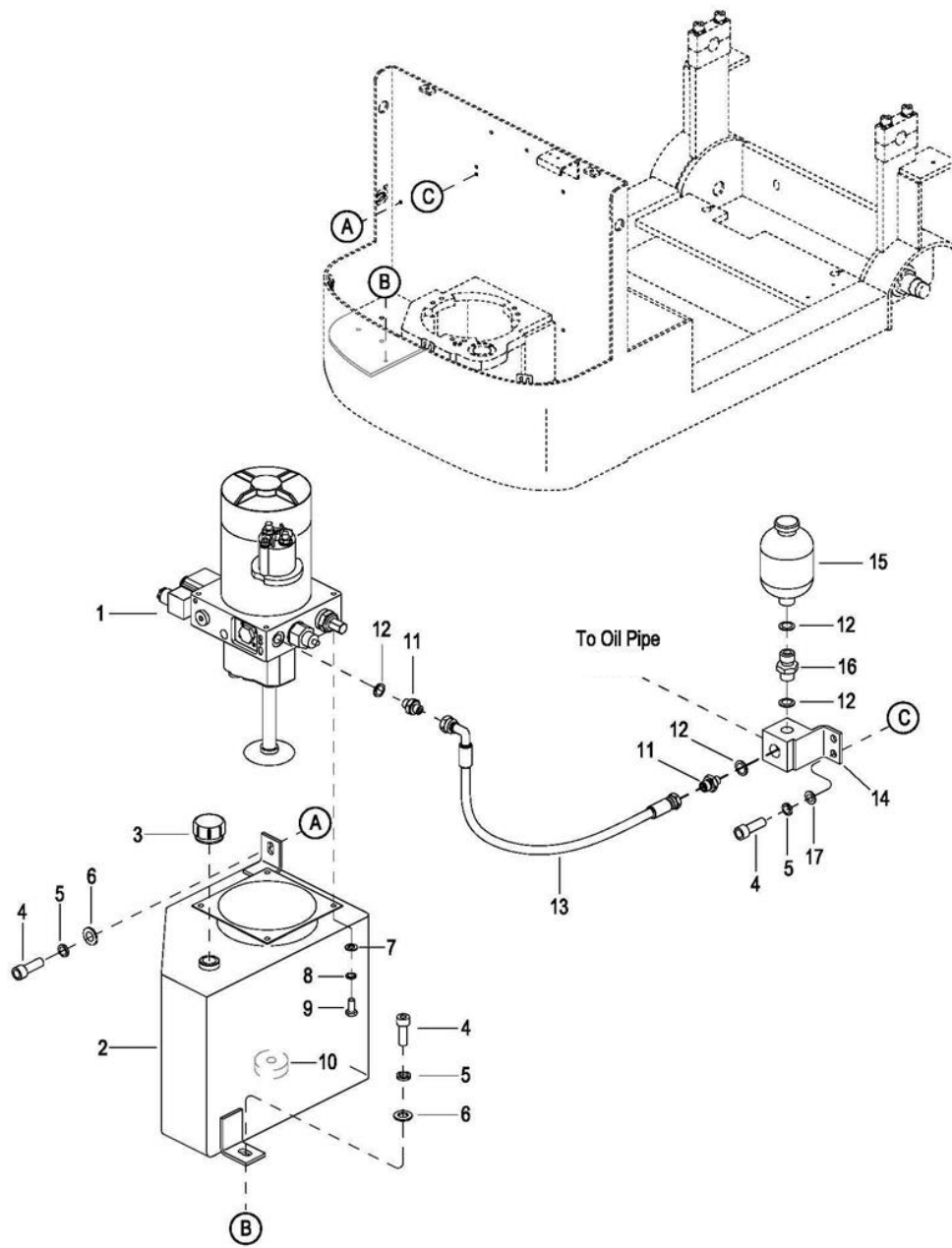

R8165

Figure 8-1 Hydraulic System

8-2.3. Installation

1. Position pump/motor assembly on reservoir and install four screws, four lock washers and four flat washers.
2. Reconnect hose to pump/motor assembly.
3. Connect electrical leads to motor and solenoid of pump/motor assembly.
4. Fill the hydraulic reservoir. Use hydraulic oil listed in [Table 2-2](#).
5. Disengage the emergency power disconnect switch and turn on key switch.
6. Operate the lift and lower buttons to refill the cylinder and lines with hydraulic oil.
7. Check level of hydraulic oil. If required, add hydraulic oil to bring to proper level. Use hydraulic oil listed in [Table 2-2](#).
8. Install the compartment cover as described in paragraph [4-2](#).

8-3. Lift Cylinder (Full Free Lift)

8-3.1. Removal

1. With the vehicle wheels securely blocked, raise the platform approximately three feet and position blocks or strong supports under Platform.
2. Lower Platform onto the support. Check that arrangement is secure before proceeding.
3. Engage the emergency power disconnect switch and turn off key switch.
4. Remove the compartment cover as described in paragraph [4-2](#).

WARNING: Before attempting any replacement, make certain power is disconnected.

CAUTION: Hydraulic oil can damage parts. Wipe off any oil immediately. Provide a container under the line or fitting before disconnecting.

5. Remove the lift chain as described in paragraph [7-4](#).
6. Remove bolt (12, [Figure 8-5](#)), lock washer (9), flat washer (10), sheave (13) and bushing (14).
7. Remove screw (8), lock washer (9), flat washer (10), angle (11), bracket (34) and header (15) from cylinder (18).

8. Disconnect the hose (13, [Figure 8-3](#)) from tube (14).
9. Remove screw (16), lock washer (17), flat washer (18) and disconnect tube (14) from connector (15).
10. Remove connector (15), two washers (5) and relief valve (6) from cylinder (25).

WARNING: Support lift cylinder before performing the following steps to prevent cylinder from falling.

11. Remove two bolts (30, [Figure 8-5](#)), two lock washers (9), two flat washers (10).
12. Raise lift cylinder assembly (18) up and out of vehicle.

8-3.2. Repair

CAUTION: To prevent damage, use proper pipe clamp vise. The cylinder will be distorted if the vise is tightened too much.

1. Secure the lift cylinder in a vise, clamping lightly at the base of the cylinder.
2. Remove gland nut (4, [Figure 8-2](#)).
3. Remove wiper ring (1), backup ring (2), packing (3) and O-ring (5) from gland nut (4).
4. Pull out piston rod (6).
5. Remove screw (9) and piston (7) from rod (6).
6. Remove ring (8) from piston (7).
7. Coat all parts with hydraulic oil ([Table 2-2](#)).
8. Install ring (8) on piston (7).
9. Install piston (7) on rod (6) and secure with screw (9).
10. Insert rod (7) in cylinder tube (10).
11. Install wiper ring (1), backup ring (2), packing (3) and O-ring (5) on gland nut (4).
12. Install gland nut (4) in cylinder tube (10).

8-3.3. Installation

1. Position the cylinder (18, [Figure 8-5](#)) in the mast (33).
2. Install two bolts (30), two lock washers (9), and two flat washers (10).
3. Install relief valve (6, [Figure 8-3](#)), two washers (5) and connector on cylinder (25).

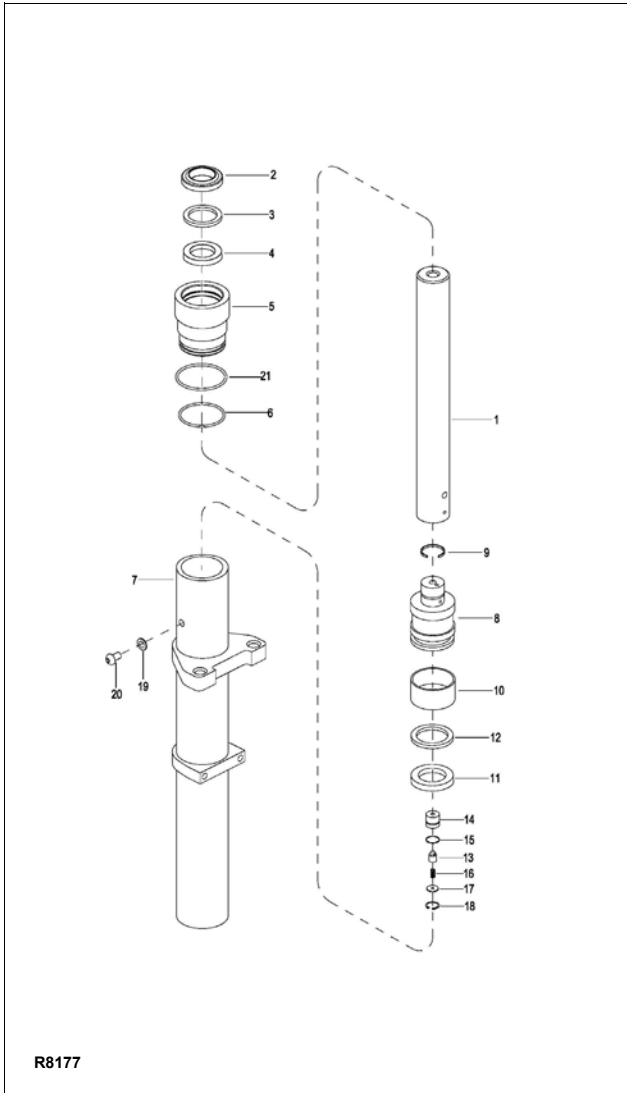

Figure 8-2 Lift Cylinder (Full Free Lift)

4. Reconnect tube (14, [Figure 8-5](#)) to connector (15) and secure the tube with screw (16), lock washer (17) and flat washer (18).
5. Position header (15), bracket (34) and angle (11) on top of cylinder (18) and secure with screw (8), lock washer (9) and flat washer (10).

6. Install bushing (14), sheave (13) on angle (11) and secure with bolt (12), lock washer (9) and flat washer (10).
7. Install lift chains as described in paragraph [7-4](#).
8. Lift inner mast (11) and remove the blocking.
9. Fill the hydraulic reservoir. Use hydraulic oil listed in [Table 2-2](#).
10. Disengage the emergency power disconnect switch and turn on key switch.

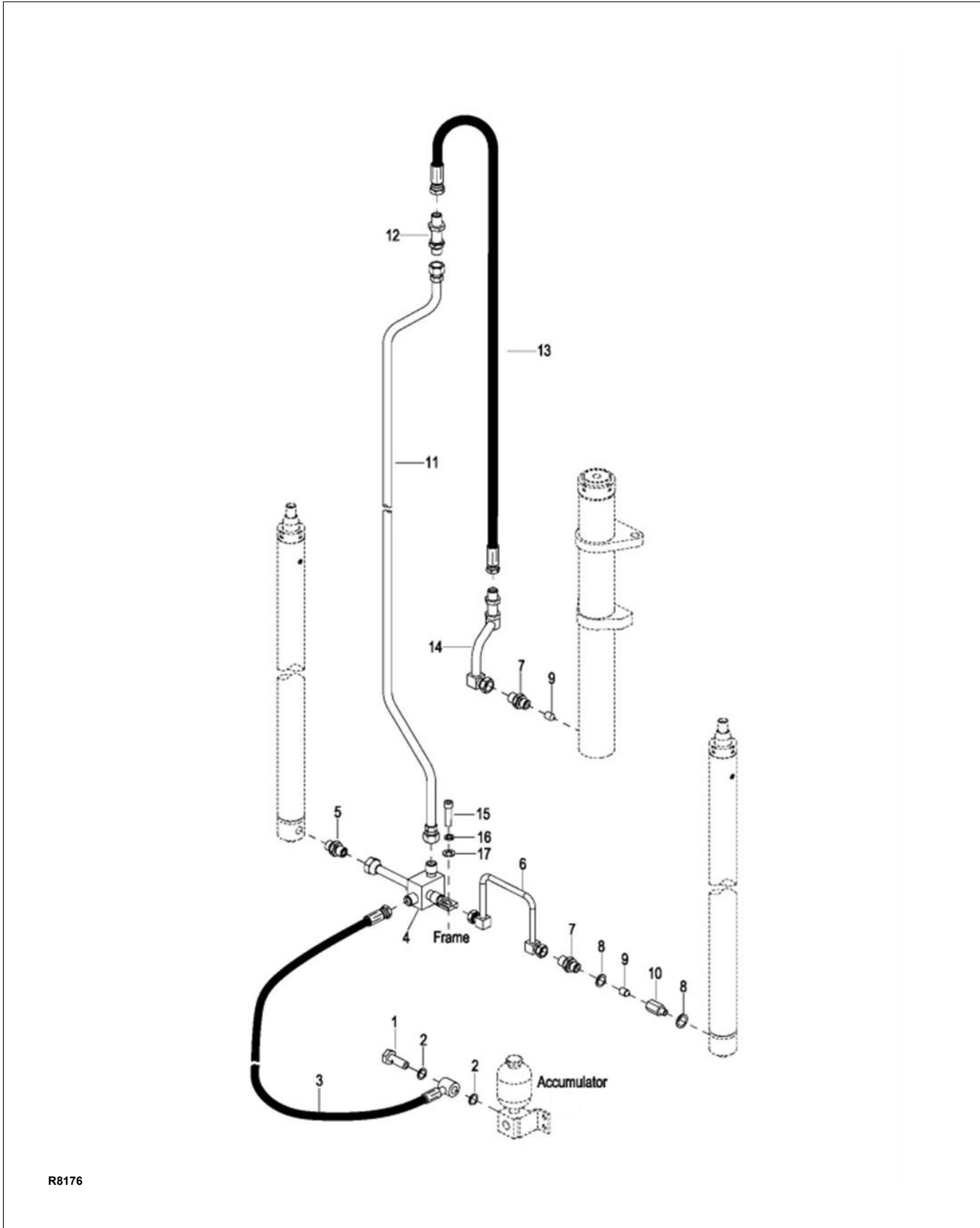
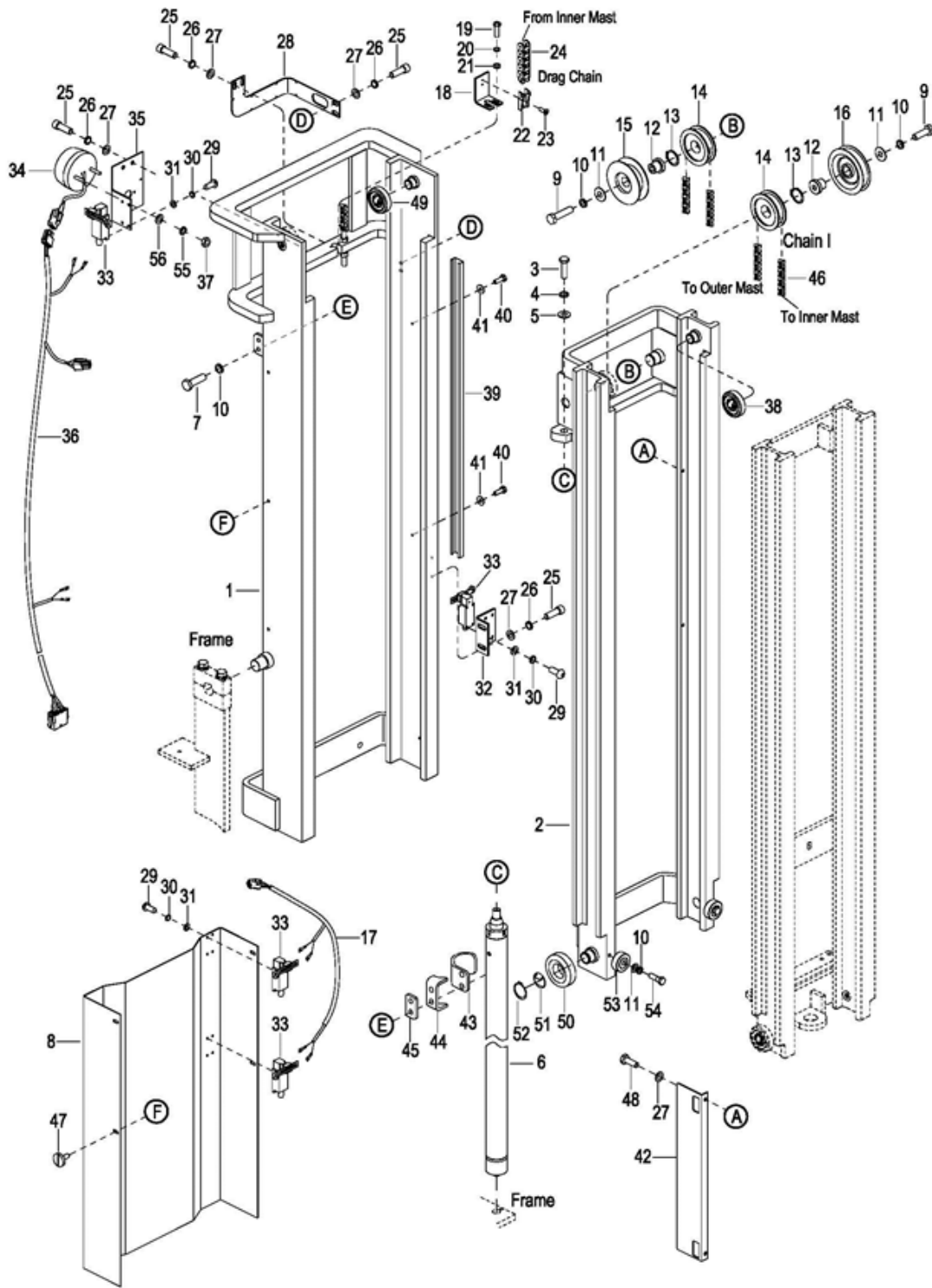
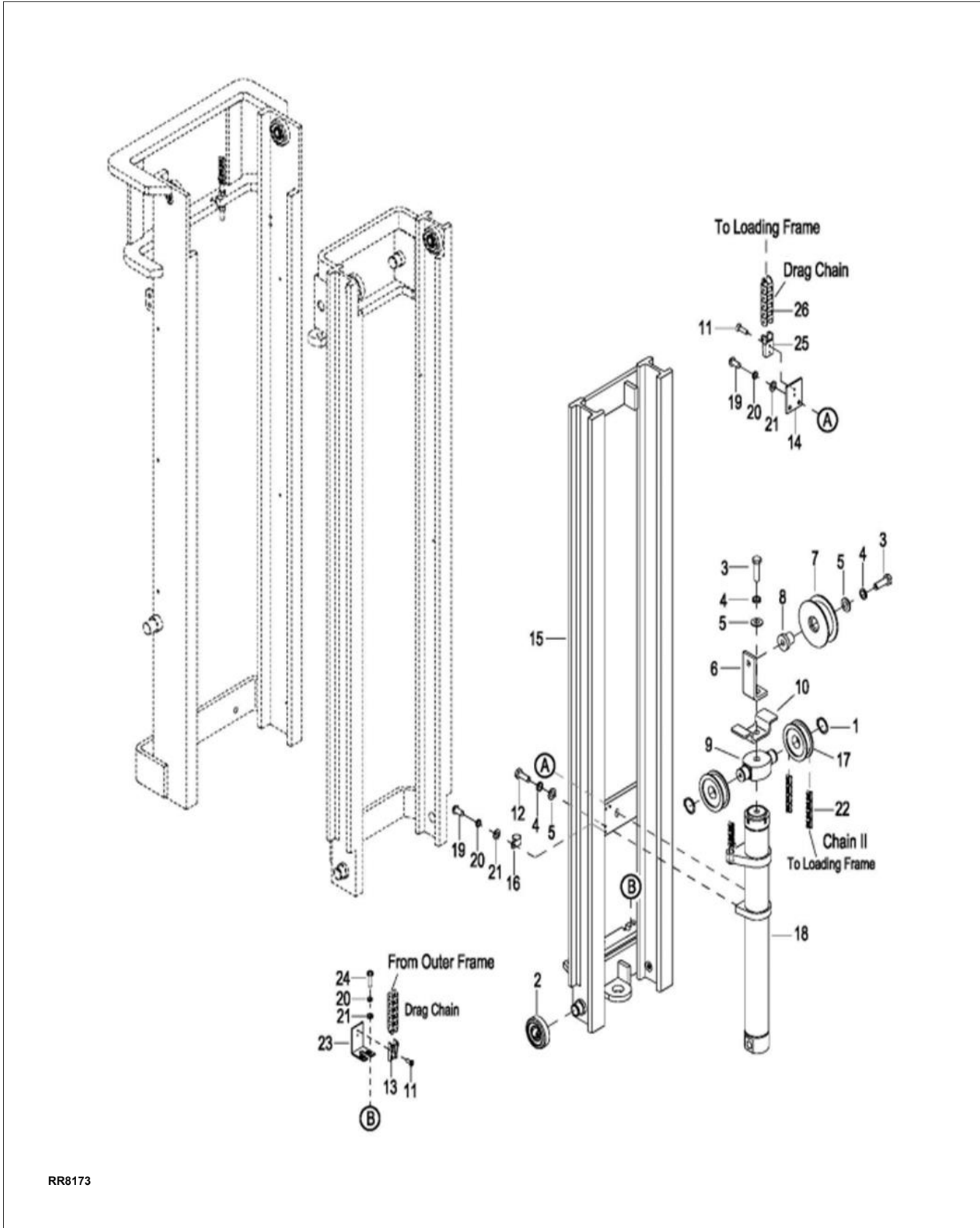

Figure 8-3 Hydraulic Lines



R8172

Figure 8-4 Elevation System - Part 1



RR8173

Figure 8-5 Elevation System - Part 2

11. Operate the lift and lower buttons to refill the cylinder and lines with hydraulic oil.
12. Check level of hydraulic oil. If required, add hydraulic oil to bring to proper level. Use hydraulic oil listed in [Table 2-2](#).
13. Adjust the chains according to paragraph [7-2](#).
14. Install the compartment cover as described in paragraph [4-2](#).

8-4. Lift Cylinder (Three Stage Mast Secondary)

8-4.1. Removal

1. With the vehicle wheels securely blocked, raise the platform approximately three feet and position blocks or strong supports under middle mast ([Figure 8-4](#)).
2. Lower mast onto the support. Check that arrangement is secure before proceeding.
3. Engage the emergency power disconnect switch and turn off key switch (3).
4. Remove the compartment cover as described in paragraph [4-2](#).

WARNING: Before attempting any replacement, make certain power is disconnected.

CAUTION: Hydraulic oil can damage parts. Wipe off any oil immediately. Provide a container under the line or fitting before disconnecting.

5. Remove the lift chain as described in paragraph [7-4](#).
6. Disconnect the tube (3 or 10, [Figure 8-3](#)) from the cylinder being removed.
7. Remove connector (2) and washer (1); or connector (4), washer (5), relief valve (23), connector (7) and washer (1) from the cylinder being removed.

WARNING: Support lift cylinder before performing the following steps to prevent cylinder from falling.

8. Remove two bolts (3, [Figure 8-4](#)), two lock washers (4) and two flat washers (5).
9. Raise lift cylinder assembly (6) up and out of vehicle.

8-4.2. Repair

CAUTION: To prevent damage, use proper pipe clamp vise. The cylinder will be distorted if the vise is tightened too much.

1. Secure the lift cylinder in a vise, clamping lightly at the base of the cylinder.

2. Remove screw (11, [Figure 8-6](#)) and washer (12).
3. Remove gland nut (3).
4. Remove wiper ring (1), packing (2) and O-rings (4 and 13) from gland nut (3).
5. Pull out piston rod (5).
6. Remove buffer rod (14), ring (8), snap ring (7) and bushing (6) from piston rod (5).
7. Coat all parts with hydraulic oil ([Table 2-2](#)).
8. Install buffer rod (14), ring (8), snap ring (7) and bushing (6) on piston rod (5).
9. Insert rod (5) in cylinder tube (9).
10. Install wiper ring (1), packing (2) and O-rings (4 and 13) on gland nut (3).
11. Install gland nut (3) in cylinder tube (9).

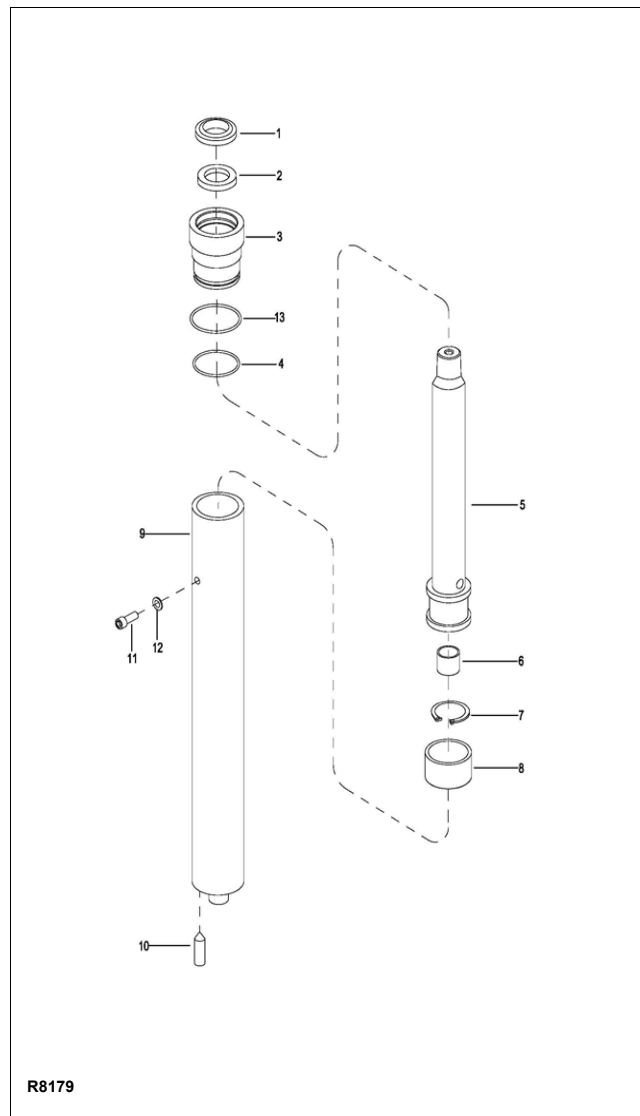

Figure 8-6 Lift Cylinder (Secondary)

8-4.3. Installation

1. Position the cylinder (6, [Figure 8-4](#)) on the frame.
2. Lift middle mast (2) and remove the blocking.
3. Install two bolts (3), two lock washers (4), and two flat washers (5).
4. Install connector (2) and washer (1); or connector (4), washer (5), relief valve (23), connector (7) and washer (1) two washers (5) and connector on cylinder (25).
5. Reconnect tube (3 or 10).
6. Install lift chains as described in paragraph [7-4](#).
7. Fill the hydraulic reservoir. Use hydraulic oil listed in [Table 2-2](#).
8. Disengage the emergency power disconnect switch and turn on key switch.
9. Operate the lift and lower buttons to refill the cylinder and lines with hydraulic oil.
10. Check level of hydraulic oil. If required, add hydraulic oil to bring to proper level. Use hydraulic oil listed in [Table 2-2](#).
11. Adjust the chains according to paragraph [7-2](#).
12. Install the compartment cover as described in paragraph [4-2](#).

NOTES

SECTION 9 ELECTRICAL COMPONENTS

9-1. ELECTRICAL CONTROL PANEL

9-1.1. Maintenance

NOTE: Erratic operation of the vehicle may be caused by defective controller components. Before removing the electrical panel, perform troubleshooting procedures per [SECTION 3](#), to determine corrective action to be taken.

There are no user-serviceable parts inside the controller. No attempt should be made to open the controller. Opening the controller may damage it and will void the warranty.

The controller is programmed at the factory specifically for the vehicle model on which it is equipped. It is important to replace the controller with the correct pre-programmed unit to assure proper performance settings intended for that particular vehicle. See [Figure 11-18](#) for the preprogrammed controller number.

It is recommended that the controller exterior be cleaned periodically, and if a hand held programmer is available, this periodic cleaning provides a good opportunity to check the controller's diagnostic history file. It is also recommended that the controller's fault detection circuitry be checked whenever the vehicle is serviced.

9-1.2. Cleaning

1. Engage the emergency power disconnect switch and turn off key switch.
2. Remove the compartment cover as described in [paragraph 4-2](#).
3. Remove any dirt or corrosion from the bus bar area. The controller should be wiped clean with a moist rag. Allow it to dry before reconnecting the battery.

9-1.3. Panel Removal.

1. Engage the emergency power disconnect switch and turn off key switch.

2. Remove the compartment cover as described in [paragraph 4-2](#).
3. Tag and disconnect all electrical cables and harness from control panel.
4. Remove four screws, four lock washers, four flat washers and panel.

9-1.4. Panel disassembly.

Refer to [Figure 11-18](#) for the location and identity of the major replacement components mounted on the panel and remove defective parts.

9-1.5. Panel Installation.

1. Position panel and secure with four screws, four lock washers, four flat washers.
2. Connect all electrical cables and harness to the control panel as noted during removal.
3. Install compartment covers as described in [paragraph 4-2](#).
4. Disengage the emergency power disconnect switch and turn on key switch.

9-2. HORN REPLACEMENT.

1. Engage the emergency power disconnect switch and turn off key switch.
2. Remove the compartment cover as described in [paragraph 4-2](#).
3. Tag and disconnect harness from horn.
4. Remove screw, lock washer, flat washer and horn.
5. Install horn and secure with screw, lock washer , flat washer.
6. Reconnect harness (to horn).
7. Install compartment covers as described in [paragraph 4-2](#).
8. Disengage the emergency power disconnect switch and turn on key switch.

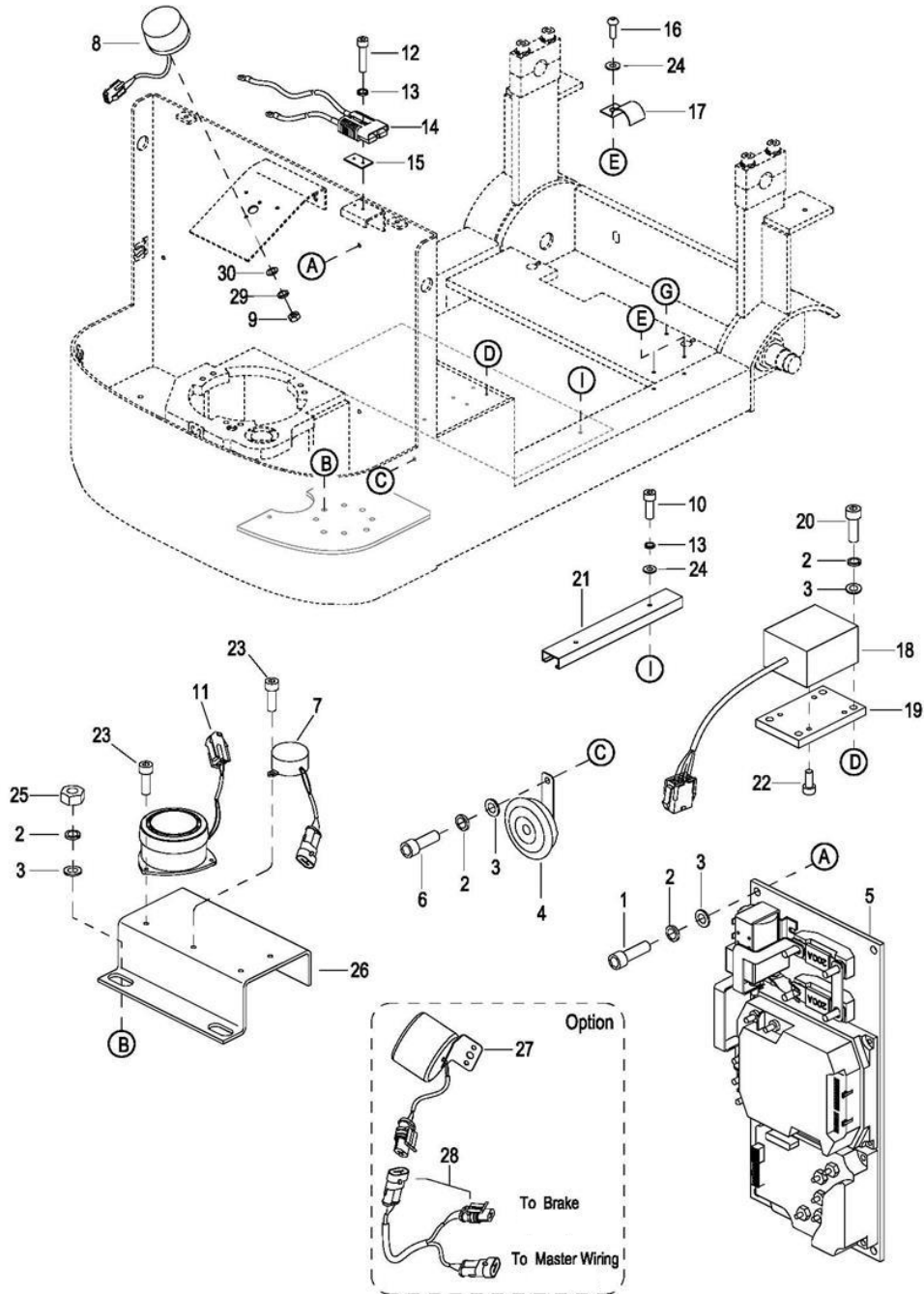

R8167

Figure 9-1 Electrical System

9-3. LOWERING BUZZER REPLACEMENT.

1. Engage the emergency power disconnect switch and turn off key switch.
2. Remove the compartment cover as described in paragraph 4-2.
3. Tag and disconnect harness from buzzer.
4. Remove screw and buzzer.
5. Install new buzzer and secure with screw.
6. Reconnect harness to buzzer.
7. Install compartment covers as described in paragraph 4-2.
8. Disengage the emergency power disconnect switch and turn on key switch.

9-4. LEVEL SENSOR BUZZER REPLACEMENT.

1. Engage the emergency power disconnect switch and turn off key switch.
2. Remove the compartment cover as described in paragraph 4-2.
3. Tag and disconnect harness from buzzer.
4. Remove screw and buzzer.
5. Install new buzzer and secure with screw.
6. Reconnect harness to buzzer.
7. Install compartment covers as described in paragraph 4-2.
8. Disengage the emergency power disconnect switch and turn on key switch.

9-5. LEVEL SENSOR REPLACEMENT.

1. Engage the emergency power disconnect switch and turn off key switch.
2. Remove the battery as described in paragraph 2-7.
3. Tag and disconnect harness from sensor.
4. Remove four screws, four lock washers and four flat washers.
5. Remove mounting plate with sensor.
6. Remove four screws and separate sensor from mounting plate.
7. Position new sensor on mounting plate and secure with four screws.
8. Install mounting plate with sensor and secure with four screws, four lock washers and four flat washers.
9. Reconnect harness to sensor.

10. Install the battery as described in paragraph 2-7.
11. Disengage the emergency power disconnect switch and turn on key switch.

9-6. WARNING LIGHT REPLACEMENT.

1. Engage the emergency power disconnect switch and turn off key switch.
2. Remove the compartment cover as described in paragraph 4-2.
3. Tag and disconnect harness from light.
4. Remove two screws and light.
5. Install new light and secure with two screws.
6. Reconnect harness to light.
7. Install compartment covers as described in paragraph 4-2.
8. Disengage the emergency power disconnect switch and turn on key switch.

9-7. BATTERY REPLACEMENT.

Replace the battery as described in paragraph 2-7.

9-8. BATTERY CHARGER.

9-8.1. Removal.

1. Engage the emergency power disconnect switch and turn off key switch.
2. Remove the battery as described in paragraph 2-7.
3. Remove four screws, four lock washers, three screws and three lock washers and remove cover.
4. Disconnect cable from charger.
5. Remove two screws and two lock washers and free the charger connector from battery tray.
6. Remove two screws two lock washers, two flat washers and charger.

9-8.2. Installation.

1. Position new charger in frame and secure with two screws two lock washers, two flat washers.
2. Position charger connector on battery tray and secure with two screws and two lock washers.
3. Reconnect cable to charger.
4. Install cover and secure with four screws, four lock washers, three screws and three lock washers.
5. Install the battery as described in paragraph 2-7.

9-9. Platform CABLE REPLACEMENT..

9-9.1. Three Stage Mast

NOTE: The Three Stage Mast version uses two protective chains for the mast harness.

1. With the lift vehicle wheels securely blocked, raise the Platform approximately three feet and position blocks or strong supports under Platform.
2. Lower Platform onto the support. Check that arrangement is secure before proceeding.
3. Engage the emergency power disconnect switch and turn off key switch.
4. Disconnect harness (3, [Figure 11-19](#)) from harness (1).
5. Disconnect harness (3, [Figure 11-19](#)) from harness (25, [Figure 11-15](#)).
6. Disconnect harness (3, [Figure 11-19](#)) from harness (11, [Figure 11-16](#)).
7. Disconnect harness (3, [Figure 11-19](#)) from harness (13, [Figure 9-5](#)).
8. Disconnect harness (3, [Figure 11-19](#)) from harness (18, [Figure 9-5](#)).
9. Remove two screws (18, [Figure 11-2](#)) and disconnect mount (19) from bracket (20).
10. Disconnect protective chain (45) from mount (19).
11. Remove two screws (23, [Figure 9-3](#)) and disconnect mount (25) from bracket (26).
12. Disconnect protective chain (30) from mount (25).
13. Lift harness with protective chain (30) from sheave (13).
14. Remove harness from the protective chain (30).
15. Remove the ties securing the harness to bracket (60).
16. Remove two screws (52, [Figure 9-2](#)), two lock washers (53), two flat washers (54) and clamp (55).
17. Remove two screws (50) and disconnect mount (51) from bracket (59).
18. Disconnect protective chain (24) from mount (51).
19. Remove the two clamps (19) from brackets (18) by removing screws (7), lock washers (20), flat washers (21).
20. Remove two screws (23) and disconnect mount (22) from bracket (18).
21. Disconnect protective chain (24) from mount (22).
22. Lift harness with protective chain (24) from sheave (15).
23. Remove harness from the protective chain.
24. Install new harness by reversing the steps above.

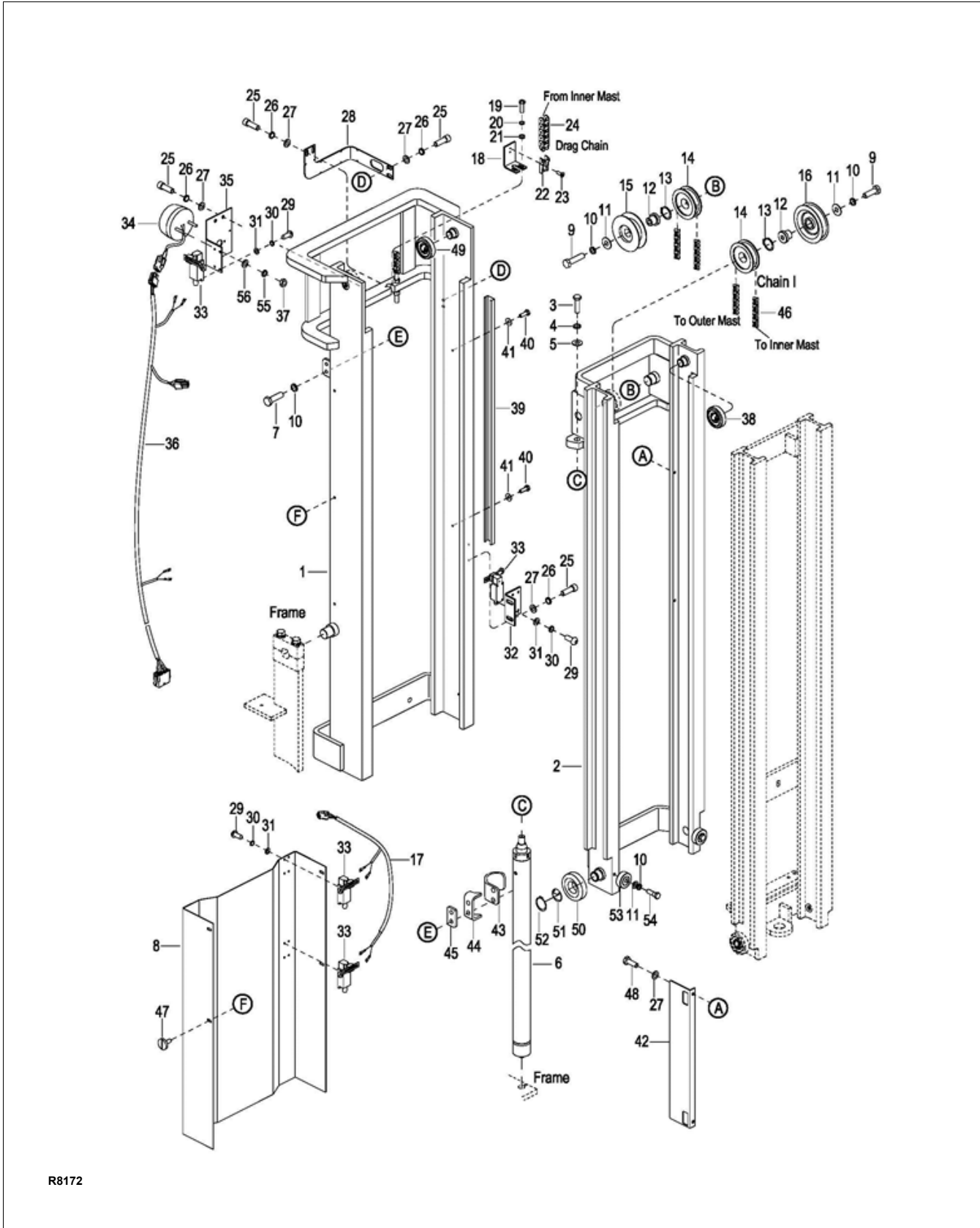

R8172

Figure 9-2 Elevation System - Part 1

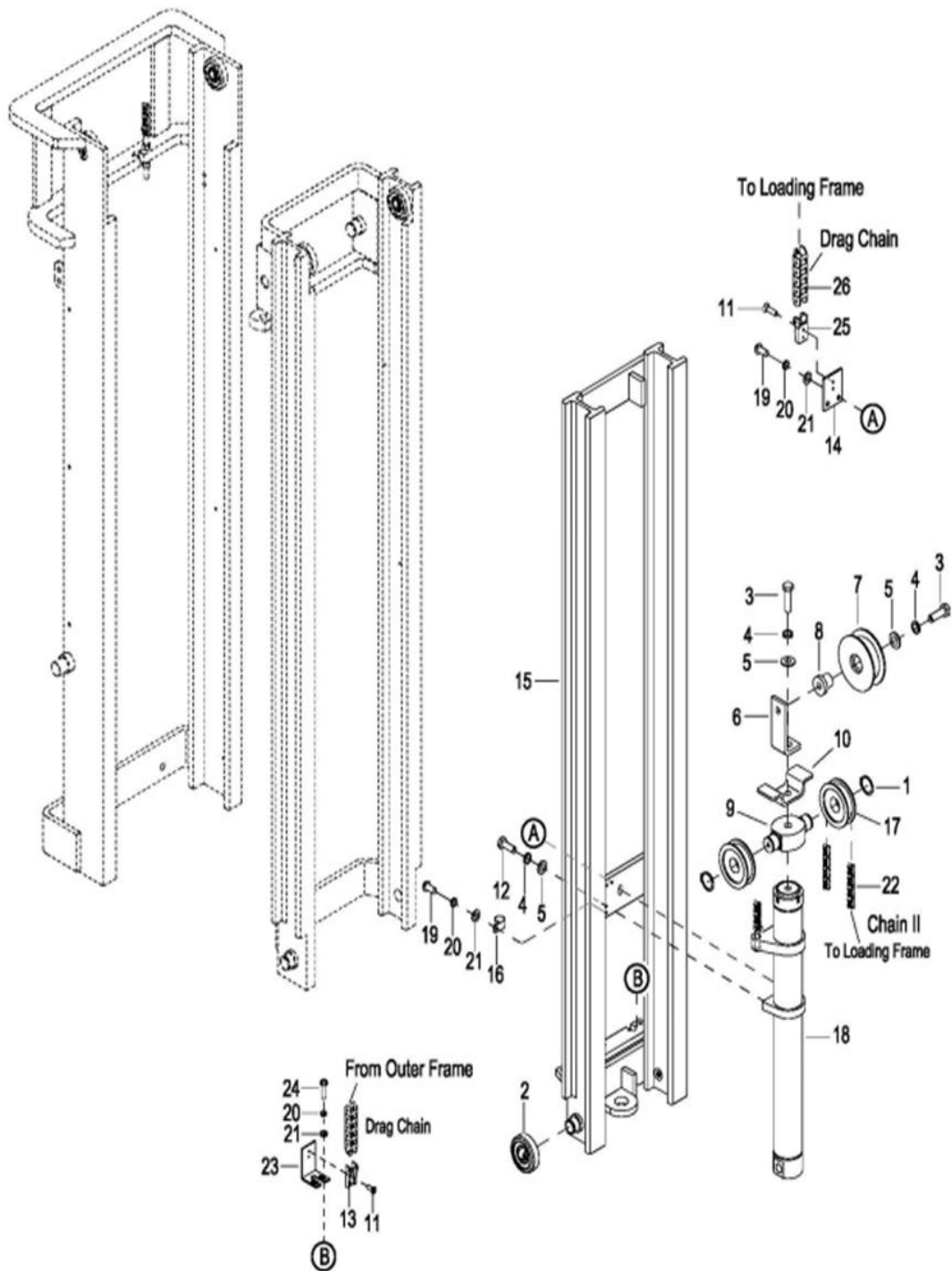

R8173

Figure 9-3 Elevation System - Part 2

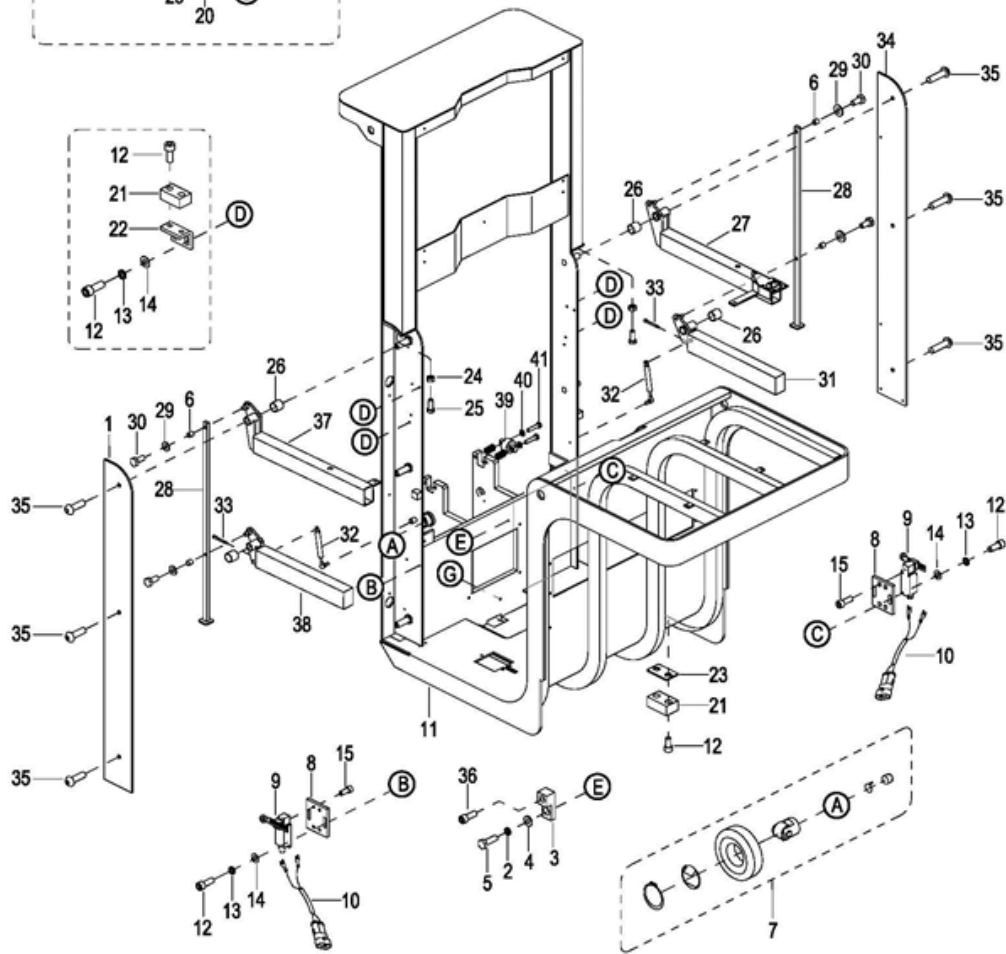
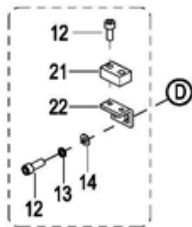
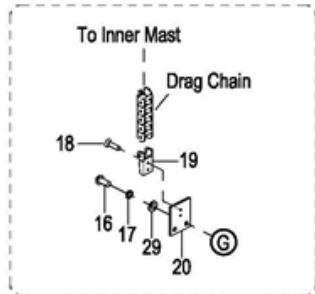

R8174

Figure 9-4 Platform Installation

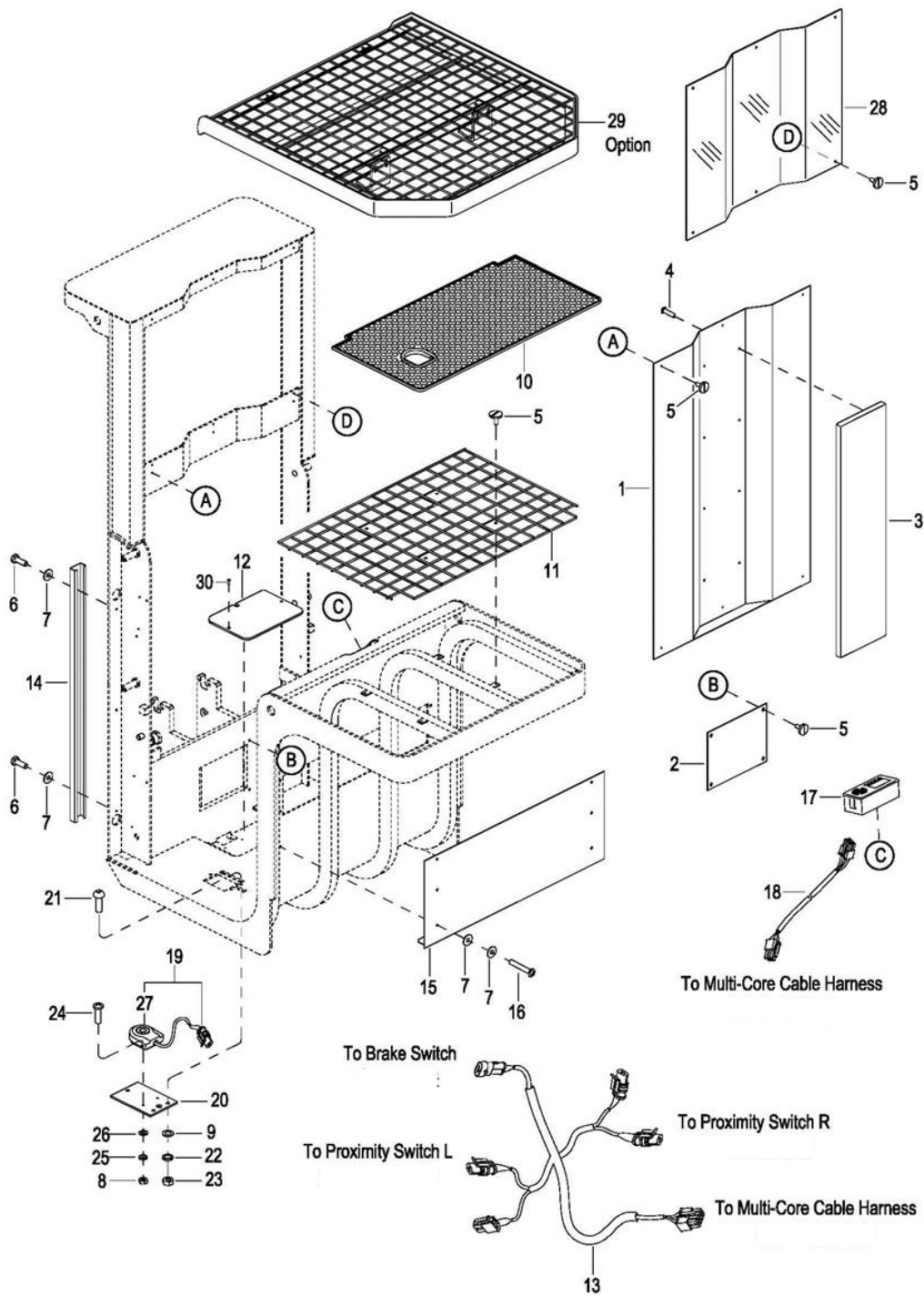

R8175

Figure 9-5 Platform Assembly

SECTION 10 OPTIONAL EQUIPMENT

10-1. INDUSTRIAL BATTERY

Contact you authorized Big Joe dealer for information on optional batteries and battery chargers.

NOTES

SECTION 11F
ILLUSTRATED PARTS BREAKDOWN

Following is an illustrated parts breakdown of assemblies and parts associated with the J1 task support vehicle.

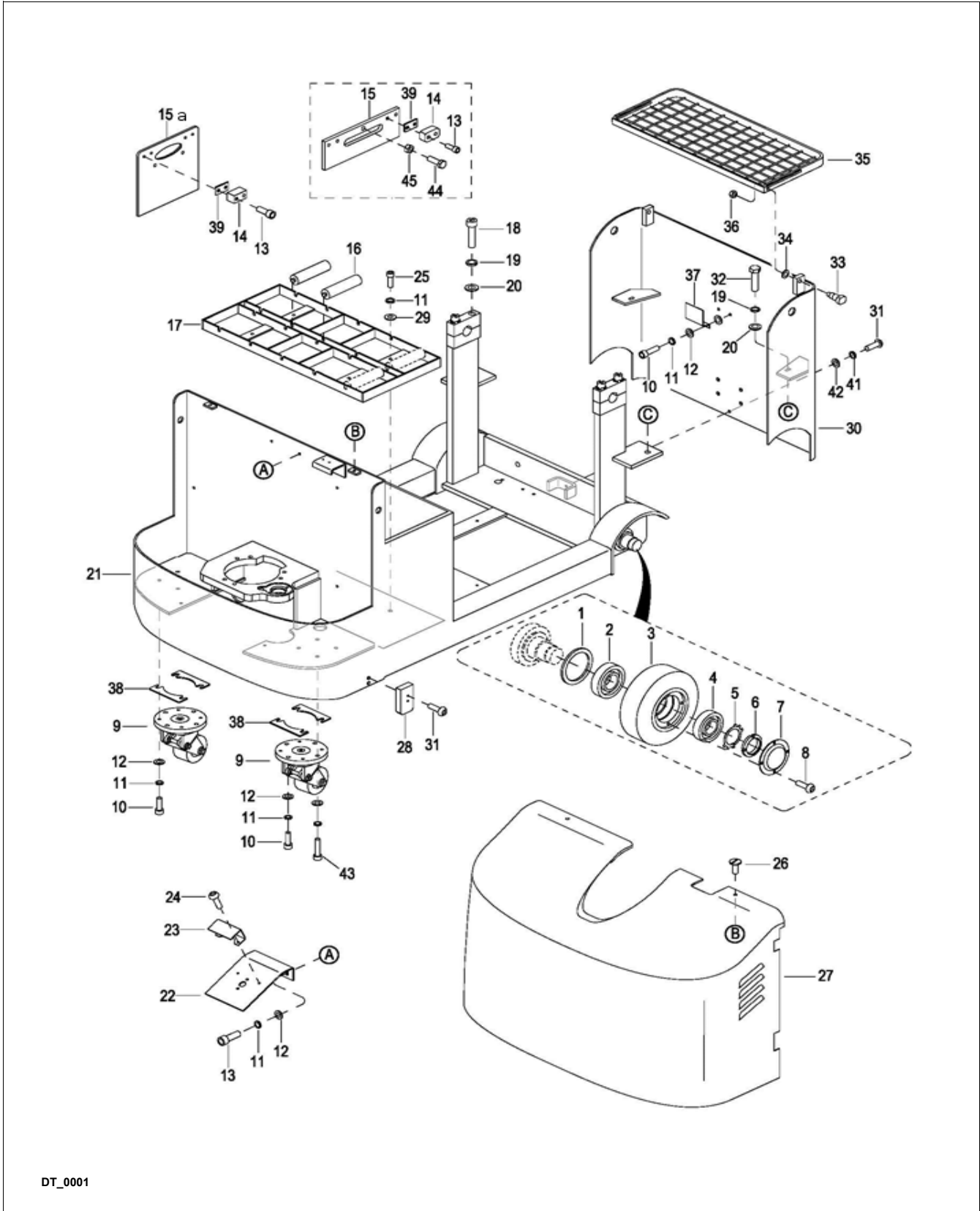

DT_0001

Figure 11-1 Frame

Frame

| POS. | PART NUMBER | DESCRIPTION | QTY. REQD. | NOTES |
|------|-------------------|------------------------------|------------|---|
| 1 | 0000-000877-00 | SEAL WASHER 60×85×8 | 2 | |
| 2 | 0000-000961-00 | BEARING | 2 | |
| 3 | CK11-140001-10 | LOAD WHEEL RUBBER | 2 | |
| 4 | 0000-000936-00 | BEARING | 2 | |
| 5 | 0000-000928-00 | LOCK WASHER Ø36 | 2 | |
| 6 | 0000-000927-00 | NUT M36×1.5 | 2 | |
| 7 | CK11-100005-00 | COVER | 2 | |
| 8 | 0000-000021-00 | SCREW M6×12 | 8 | |
| 9 | 1118-140000-00 | CASTER ASSEMBLY | 2 | Used up to Serial Number 225170105 |
| 9a | CK10-170000-00 | CASTER ASSEMBLY | 2 | Used from Serial Number 225170106 |
| 10 | 0000-000322-00 | SCREW M8×25 | 8 | |
| 11 | 0000-000159-00 | LOCK WASHER Ø8 | 16 | |
| 12 | 0000-000176-00 | FLAT WASHER Ø8 | 16 | |
| 13 | 0000-000109-00 | SCREW M8×16 | 6 | |
| 14 | 2125-600005-00 | BUFFER BLOCK | 2 | |
| 15 | 1615-140001-2A | BAFFLE 250×270×8 | 1 | Used from Serial Number 226120060 |
| 16 | 3316-814000-00 | ROLLER | 10 | |
| 17 | 1615-121000-00 | battery roller bed | 1 | |
| 18 | 0000-000432-00 | SCREW M16×80 | 4 | |
| 19 | 0000-000191-00 | LOCK WASHER Ø16 | 6 | |
| 20 | CK10-100020-00 | FLAT WASHER Ø16 | 8 | |
| 21 | CK10-110000-60 | FRAME | 1 | Used up to Serial Number 226170005 |
| 21a | CK10-110000-6B | FRAME | 1 | Used from Serial Number 226170006 |
| 22 | CK10-100001-00 | WARNING LIGHT MOUNTING PLATE | 1 | |
| 23 | CK10-100004-00 | WARNING LIGHT COVER | 1 | |
| 24 | 0000-000179-00 | SCREW M6×10 | 2 | |
| 25 | 0000-000321-00 | SCREW M8×20 | 4 | |
| 26 | 0000-000185-00 | SCREW M8×16 | 2 | |
| 27 | CK10-100005-60-01 | COVER | 1 | Used up to Serial Number 227160239 - Black |
| 27a | CK10-100007-60-01 | COVER | 1 | Used from Serial Number 227160240 - Black |
| 27b | CK10-100005-60-02 | COVER | 1 | Used up to Serial Number 227160239 - Red |
| 27c | CK10-100007-60-02 | COVER | 1 | Used from Serial Number 227160240 - Red |
| 27d | CK10-100005-60-03 | COVER | 1 | Used up to Serial Number 227160239 - Yellow |
| 27e | CK10-100007-60-03 | COVER | 1 | Used from Serial Number 227160240 - Yellow |
| 28 | CK10-100009-00 | BLOCK | 2 | |
| 29 | 0000-000194-00 | FLAT WASHER Ø8 | 4 | |

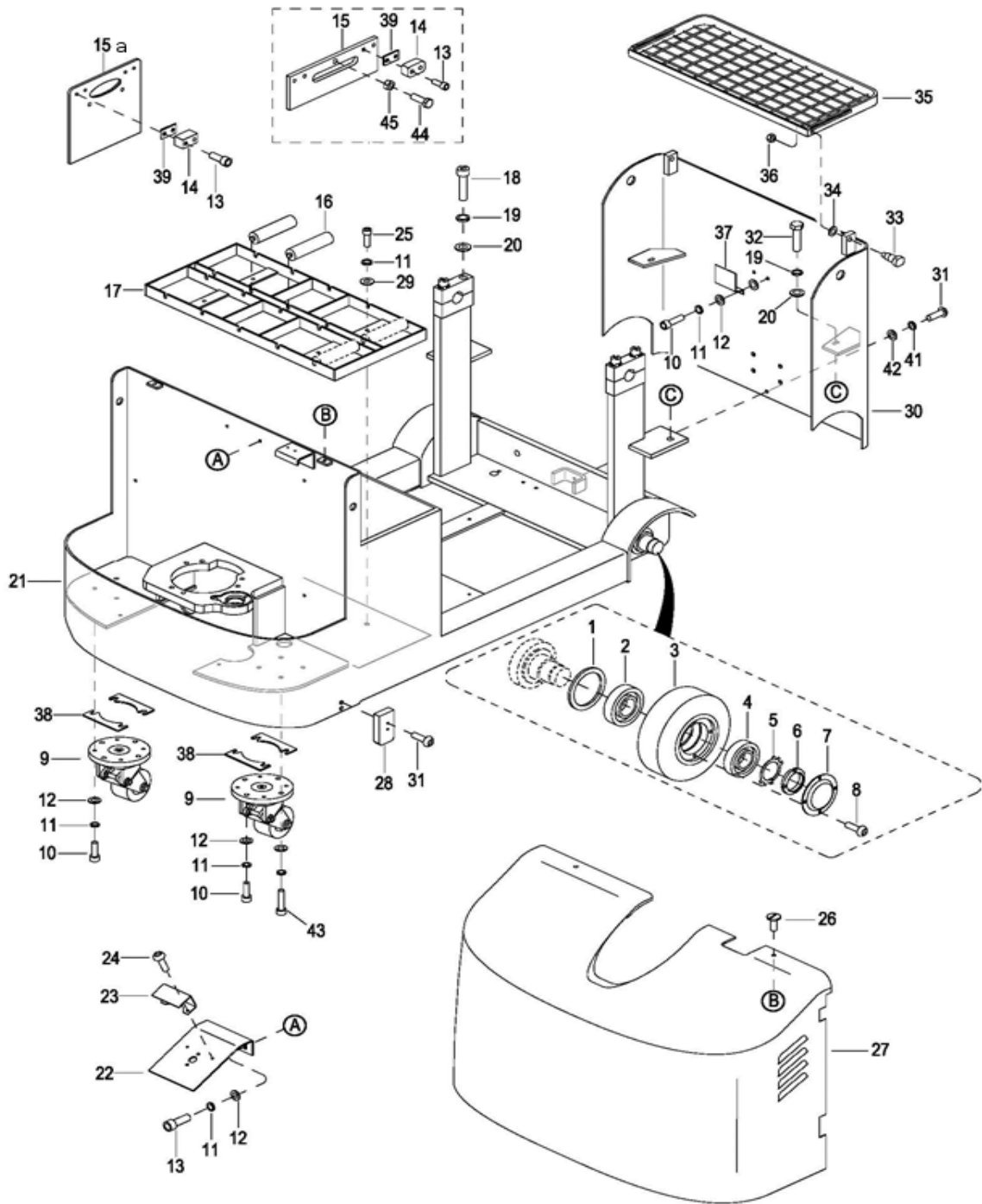

DT_0001

Figure 11-1Frame - Continued

Frame - Continued

| POS. | PART NUMBER | DESCRIPTION | QTY. REQD. | NOTES |
|------|----------------|-----------------|------------|--|
| 30 | CK10-120000-60 | MAST COVER | 1 | Used up to Serial Number 226150242 |
| 30a | CK10-120000-6A | MAST COVER | 1 | Used between Serial Number 226150243 - 2281000298 |
| 30b | CK10-180000-60 | MAST COVER | 1 | Used from Serial Number 2281000299 |
| 31 | 0000-001410-00 | SCREW M12×30 | 5 | |
| 32 | 0000-000375-00 | BOLT M16×35 | 2 | |
| 33 | CK10-100003-0D | SCREW | 2 | Replaces all previous versions of part. Includes pos.# 36, nut 0000-000426-00. |
| 34 | 0000-000222-00 | FLAT WASHER Ø12 | 2 | |
| 35 | CK10-130000-00 | TRAY | 1 | |
| 36 | -- | NUT | 2 | Included in pos. # 33 |
| 37 | CK10-100006-00 | TRAY HOLDER | 1 | |
| 38 | 2140-140005-00 | WASHER | A.R. | As Required |
| 39 | 1220-100012-80 | PLATE | A.R. | As Required |
| 40 | 0000-000996-00 | BOLT M16×45 | 2 | |
| 41 | 0000-000060-00 | LOCK WASHER Ø12 | 1 | |
| 42 | 0000-000373-00 | FLAT WASHER Ø12 | 1 | |
| 43 | 0000-000372-00 | SCREW M8×40 | 2 | |
| 44 | 0000-000285-00 | BOLT M12×35 | 1 | Used up to Serial Number 226120059 |
| 45 | 0000-000630-00 | NUT M12 | 1 | Used up to Serial Number 226120059 |

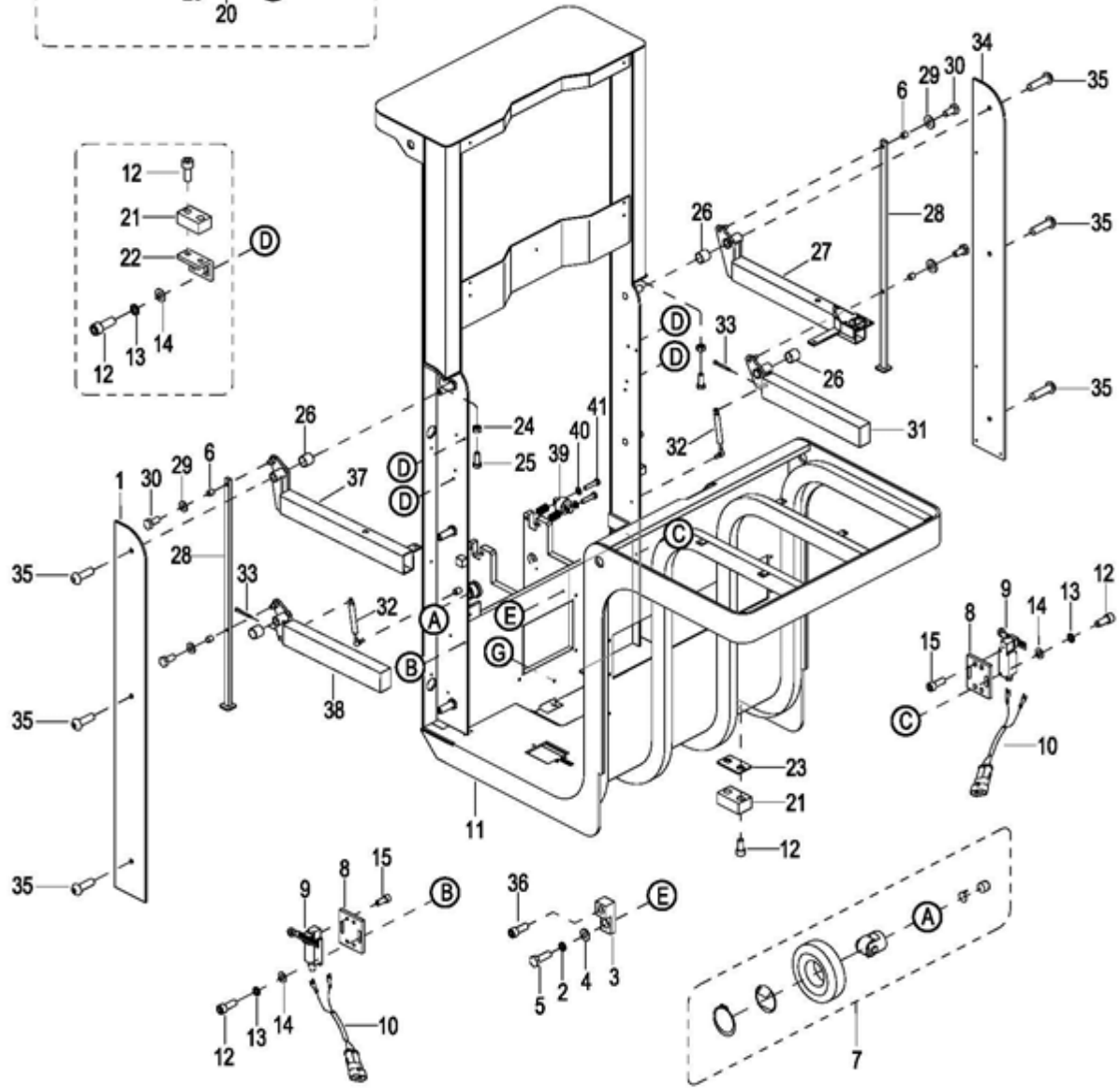
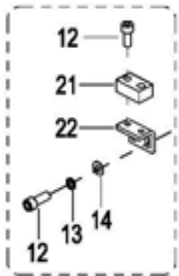
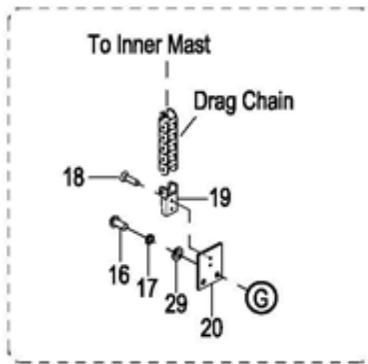

DT_0016

Figure 11-2 Platform Installation

Platform Installation

| POS. | PART NUMBER | DESCRIPTION | QTY. REQD. | NOTES |
|------|----------------|---------------------------|------------|--|
| 1 | CK10-700001-0B | COVER PLATE LEFT | 1 | |
| 2 | 0000-000060-00 | LOCK WASHER Ø12 | 1 | |
| 3 | CK10-700008-0A | PROXIMITY BLOCK | 1 | |
| 4 | 0000-000222-00 | FLAT WASHER Ø12 | 1 | |
| 5 | 0000-000285-00 | BOLT M12×35 | 1 | |
| 6 | 2028-019000-70 | BUSHING | 4 | |
| 7 | 2125-612000-00 | ROLLER ASSEMBLY | 2 | Used up to Serial number 225180154 - (78.3-12S) |
| 7a | CK10-613000-00 | ROLLER ASSEMBLY | 2 | Used from Serial number 225180155 - (79.8-1S-00) |
| 8 | CK10-510020-00 | SWITCH MOUNTING PLATE | 2 | |
| 9 | 2125-500003-00 | PROXIMITY SWITCH | 2 | |
| 10 | CK10-520013-00 | PROXIMITY SWITCH WIRING | 2 | |
| 11 | CK10-710000-60 | PLATFORM | 1 | Used up to Serial number 225180154 |
| 11a | CK10-710000-70 | PLATFORM | 1 | Used between Serial number 225180155 - 226200101 |
| 11b | CK10-710000-6A | PLATFORM | 1 | Used from Serial number 226200102 |
| 12 | 0000-000109-00 | SCREW M8×16 | 28 | |
| 13 | 0000-000159-00 | LOCK WASHER Ø8 | 12 | |
| 14 | 0000-000176-00 | FLAT WASHER Ø8 | 12 | |
| 15 | 0000-000004-00 | SCREW M5×12 | 8 | |
| 16 | 0000-000618-00 | SCREW M6×12(| 2 | |
| 17 | 0000-000056-00 | LOCK WASHER Ø6 | 2 | |
| 18 | 0000-000416-00 | SCREW M4×8 | 2 | |
| 19 | CK10-510004-00 | DRAG HEAD I (BRACKET) | 1 | |
| 20 | CK10-510011-0A | DRAG CHAIN MOUNTING PLATE | 1 | |
| 21 | 2125-600005-00 | BUFFER BLOCK | 8 | |
| 22 | CK10-700006-00 | MOUNTING PLATE | 4 | |
| 23 | 1220-100012-80 | PLATE | A.R. | As Required |
| 24 | 0000-000165-00 | NUT M12 | 2 | |
| 25 | 0000-000623-00 | BOLT M12×30 | 2 | |
| 26 | CK11-700006-0A | BUSHING | 2 | |
| 27 | CK10-730000-10 | LEFT ARMREST | 1 | |
| 28 | CK10-791000-00 | SUPPORTING ROD | 2 | |
| 29 | 0000-000380-00 | FLAT WASHER Ø6(| 8 | |
| 30 | 0000-000264-00 | BOLT M6×12 | 4 | |
| 31 | CK10-750000-10 | SQUARE TUBE LEFT | 1 | |
| 32 | CK11-700007-00 | GAS SPRING | 2 | Used up to Serial Number 226150177 |
| 32a | CK11-700007-10 | GAS SPRING | 2 | Used from Serial Number 226150178 |
| 33 | 0000-000296-00 | COTTER PIN Ø2×20 | 2 | |
| 34 | CK10-700001-0B | COVER PLATE LEFT | 1 | |
| 35 | 0000-000655-00 | SCREW M10×25 | 6 | |
| 36 | 0000-000322-00 | SCREW M8×25 | 1 | |
| 37 | CK10-740000-10 | RIGHT ARMREST | 1 | |
| 38 | CK10-760000-10 | SQUARE TUBE RIGHT | 1 | |
| 39 | CK10-700002-60 | SIDE ROLLER | 1 | Used from serial number 225100041 |
| 40 | 0000-000071-00 | FLATWASHER Ø10 | A.R. | Used from serial number 225100041 |
| 41 | 3010-020000-31 | BOLT M10×45 | 4 | Used from serial number 225100041 |

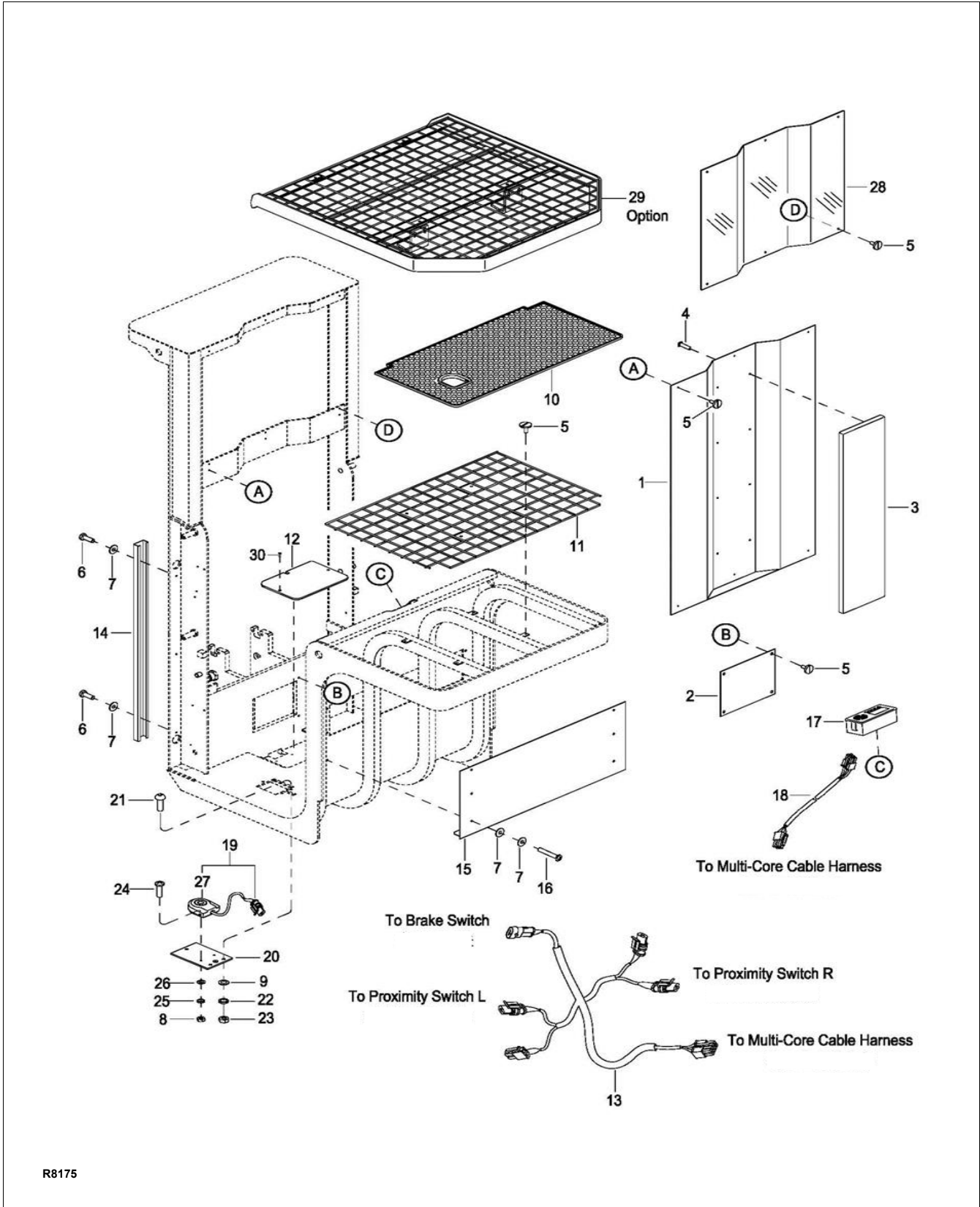

R8175

Figure 11-3 Platform Assembly

Platform Assembly

| POS. | PART NUMBER | DESCRIPTION | QTY. REQD. | NOTES |
|------|-------------------|-------------------------------------|------------|---|
| 1 | CK10-720000-60 | BOARD | 1 | |
| 2 | CK10-700005-00 | SEAL PLATE | 1 | |
| 3 | 4230-100004-00 | CUSHION | 1 | |
| 4 | 0000-000646-00 | SCREW M4×10 | 8 | |
| 5 | 2108-100006-00 | SCREW M6×10 | 18 | |
| 6 | 0000-000275-00 | BOLT M6×30 | 4 | |
| 7 | 0000-000123-00 | FLAT WASHER Ø6 | 16 | |
| 8 | 0000-000209-00 | NUT M4 | 2 | |
| 9 | 0000-000380-00 | FLAT WASHER Ø6 | 3 | |
| 10 | CK10-700004-00 | FLOOR MAT | 1 | |
| 11 | CK10-720000-50 | MESH | 1 | |
| 12 | CK10-700003-50 | COVER | 1 | Used up to Serial Number 226180178 |
| 12a | CK10-700003-30 | COVER | 1 | Used from Serial Number 226180179 |
| 13 | CK11-520004-00 | INTERLOCK PROXIMITY SWITCH WIRE | 1 | |
| 14 | CK11-700003-00 | WIRE GROOVE | 2 | |
| 15 | CK10-700007-50 | SEAL PLATE | 1 | |
| 16 | 0000-000993-00 | SCREW M6×55 | 6 | |
| 17 | CK11-560001-00-00 | INSTRUMENT PANEL (ECO) | 1 | |
| 18 | CK10-520008-00 | INSTRUMENT PANEL WIRE HARNESS (ECO) | 1 | |
| 19 | CK10-520012-00 | BRAKE SWITCH ASSEMBLY | 1 | |
| 20 | CK11-510014-00 | BRAKE SWITCH PLATE | 1 | |
| 21 | 0000-000498-00 | SCREW M6×30 | 3 | |
| 22 | 0000-000056-00 | LOCK WASHER Ø6 | 3 | |
| 23 | 0000-000166-00 | NUT M6 | 3 | |
| 24 | 3020-040000-05 | SCREW M4×12 | 2 | |
| 25 | 0000-000122-00 | LOCK WASHER Ø4 | 2 | |
| 26 | 0000-000702-00 | FLAT WASHER Ø4 | 2 | |
| 27 | CK10-560011-00 | BRAKE SWITCH | 1 | |
| 28 | CK10-700001-60 | WINDSHIELD | 1 | |
| 29 | -- | TRAY ASSEMBLY | 1 | This is an option that will derate the truck. Please contact the factory for information. |
| 30 | 0000-000090-00 | SCREW M6X12 | 2 | |

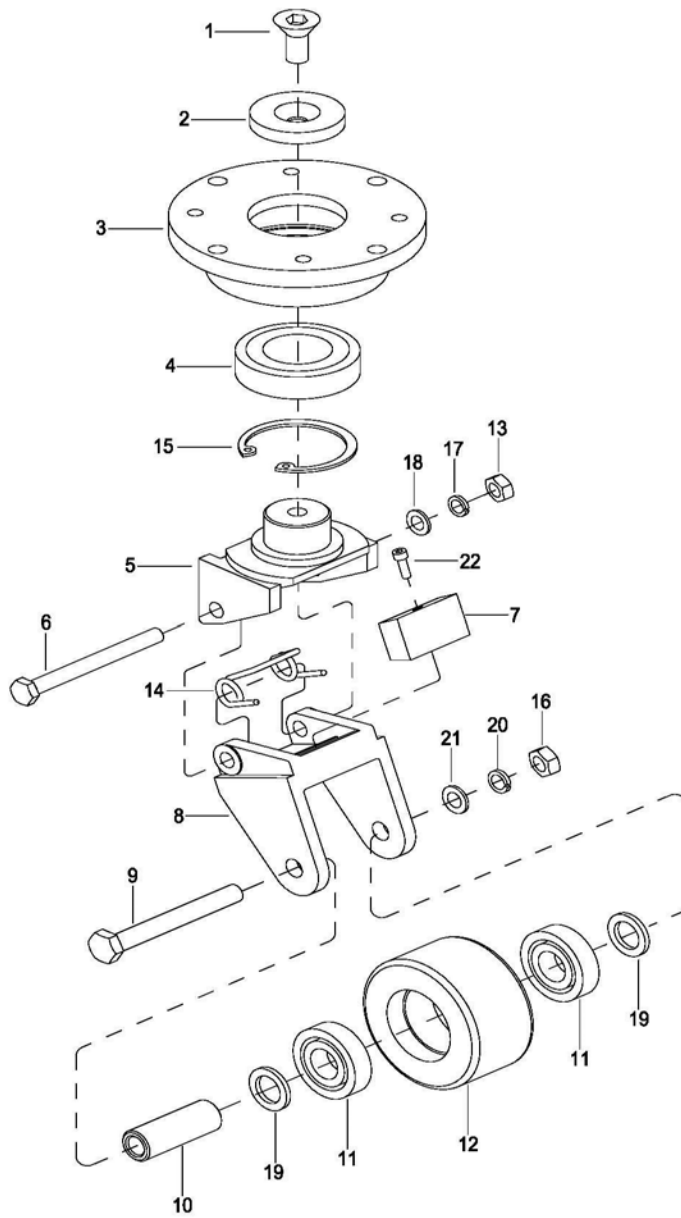

R8160

Figure 11-4 Caster Assembly - Used up to Serial Number 225170105

Caster Assembly - Used up to Serial Number 225170105

| POS. | PART NUMBER | DESCRIPTION | QTY. REQD. | NOTES |
|------|----------------|-----------------|------------|---------------------|
| -- | 1118-140000-00 | CASTER ASSEMBLY | 2 | 2 Casters per truck |
| 1 | 0000-000985-00 | SCREW M10×20 | 1 | |
| 2 | 1118-140003-00 | PLATE | 1 | |
| 3 | 1118-140001-00 | CASTER SUPPORT | 1 | |
| 4 | 0000-000986-00 | BEARING | 1 | |
| 5 | 1118-140002-00 | CASTER SUPPORT | 1 | |
| 6 | 0000-000168-00 | BOLT M10×90 | 1 | |
| 7 | 1120-140003-00 | PU BLOCK | 1 | |
| 8 | 1120-142000-00 | WHEEL BRACKET | 1 | |
| 9 | 0000-000495-00 | BOLT M12×85 | 1 | |
| 10 | 1120-143001-00 | SHAFT | 1 | |
| 11 | 0000-000020-00 | BEARING | 2 | |
| 12 | 1120-143003-00 | CASTER WHEEL | 1 | |
| 13 | 0000-000426-00 | NUT M10 | 1 | |
| 14 | 1120-140004-00 | SPRING | 1 | |
| 15 | 0000-000987-00 | SNAP RING Ø80 | 1 | |
| 16 | 0000-000057-00 | NUT M12 | 1 | |
| 17 | 0000-000063-00 | LOCK WASHER Ø10 | 1 | |
| 18 | 0000-000007-00 | FLAT WASHER Ø10 | 1 | |
| 19 | 0000-000435-00 | FLAT WASHER Ø20 | 2 | |
| 20 | 0000-000060-00 | LOCK WASHER Ø12 | 1 | |
| 21 | 0000-000373-00 | FLAT WASHER Ø12 | 1 | |
| 22 | 0000-000004-00 | SCREW M5×12 | 1 | |

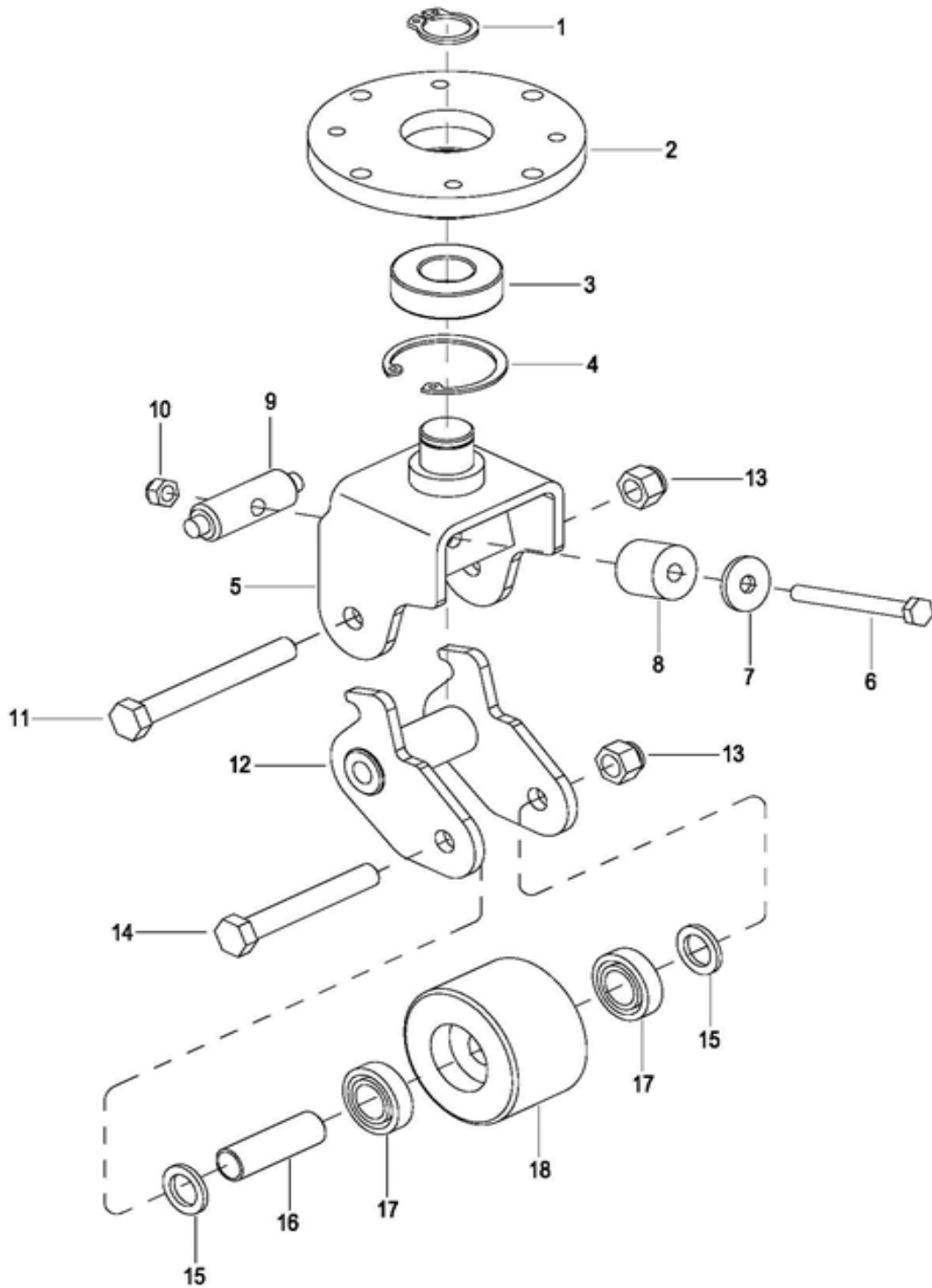

R8263

Figure 11-5 Caster Assembly - Used from Serial Number 225170106

Caster Assembly - Used from Serial Number 225170106

| POS. | PART NUMBER | DESCRIPTION | QTY. REQD. | NOTES |
|------|----------------|--------------------|------------|--|
| -- | CK10-170000-00 | CASTER ASSEMBLY | 2 | 2 Casters per truck |
| 1 | 0000-000294-00 | RETAINER RING Ø25 | 1 | |
| 2 | CK10-171001-00 | CASTER SUPPORT | 1 | |
| 3 | 0000-000100-00 | BEARING | 1 | |
| 4 | 0000-000758-00 | ELASTIC COLLAR Ø52 | 1 | |
| 5 | 1115-032300-A0 | CASTER SUPPORT | 1 | |
| 6 | 0000-000281-00 | BOLT M8×80 | 1 | |
| 7 | 0000-000373-00 | FLATWASHER Ø12 | 1 | |
| 8 | 1115-032002-A0 | BUFFER BLOCK | 1 | Used between Serial Number 225170106 - 226180177 |
| 8a | CK10-171004-00 | BUFFER BLOCK | 1 | Used from Serial Number 226180178 |
| 9 | 1115-032001-A0 | ROD | 1 | |
| 10 | 0000-000740-00 | NUT M8 | 1 | |
| 11 | 0000-001413-00 | BOLT M12×100 | 1 | |
| 12 | 1115-032200-A0 | WHEEL BRACKET | 1 | |
| 13 | 0000-001334-00 | NUT M12 | 2 | |
| 14 | 0000-000495-00 | BOLT M12×85 | 1 | |
| 15 | 0000-000435-00 | FLATWASHER Ø20 | 2 | |
| 16 | 1120-143001-00 | SHAFT | 1 | |
| 17 | 0000-000020-00 | BEARING | 2 | |
| 18 | 1115-172101-H0 | PU WHEEL | 1 | |

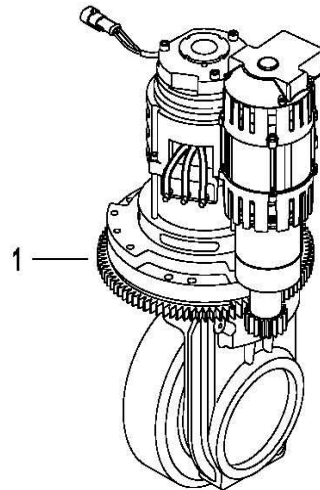
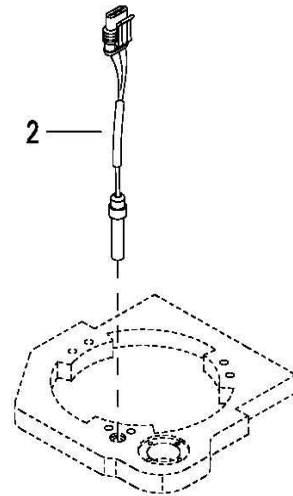
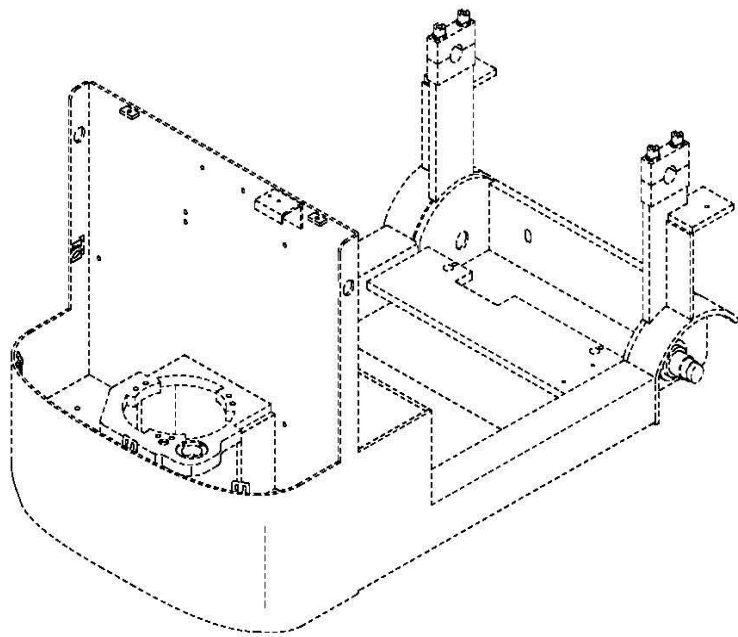

R8162

Figure 11-6 Drive System

Drive System

| POS. | PART NUMBER | DESCRIPTION | QTY. REQD. | NOTES |
|------|-------------------|------------------------|------------|---|
| 1 | CK10-200000-1A | DRIVE ASSEMBLY | 1 | Used up to Serial Number 224190036 - See Transmission and Motor section |
| 1a | CK10-200000-1B | DRIVE ASSEMBLY | 1 | Used from Serial Number 224190037 - See Transmission and Motor section |
| 2 | 1280-520009-10-01 | SWITCH WIRE HARNESS II | 1 | Used up to Serial Number 226170005 |
| 2a | 1280-520009-1A-01 | SWITCH WIRE HARNESS II | 1 | Used from Serial Number 226170006 |

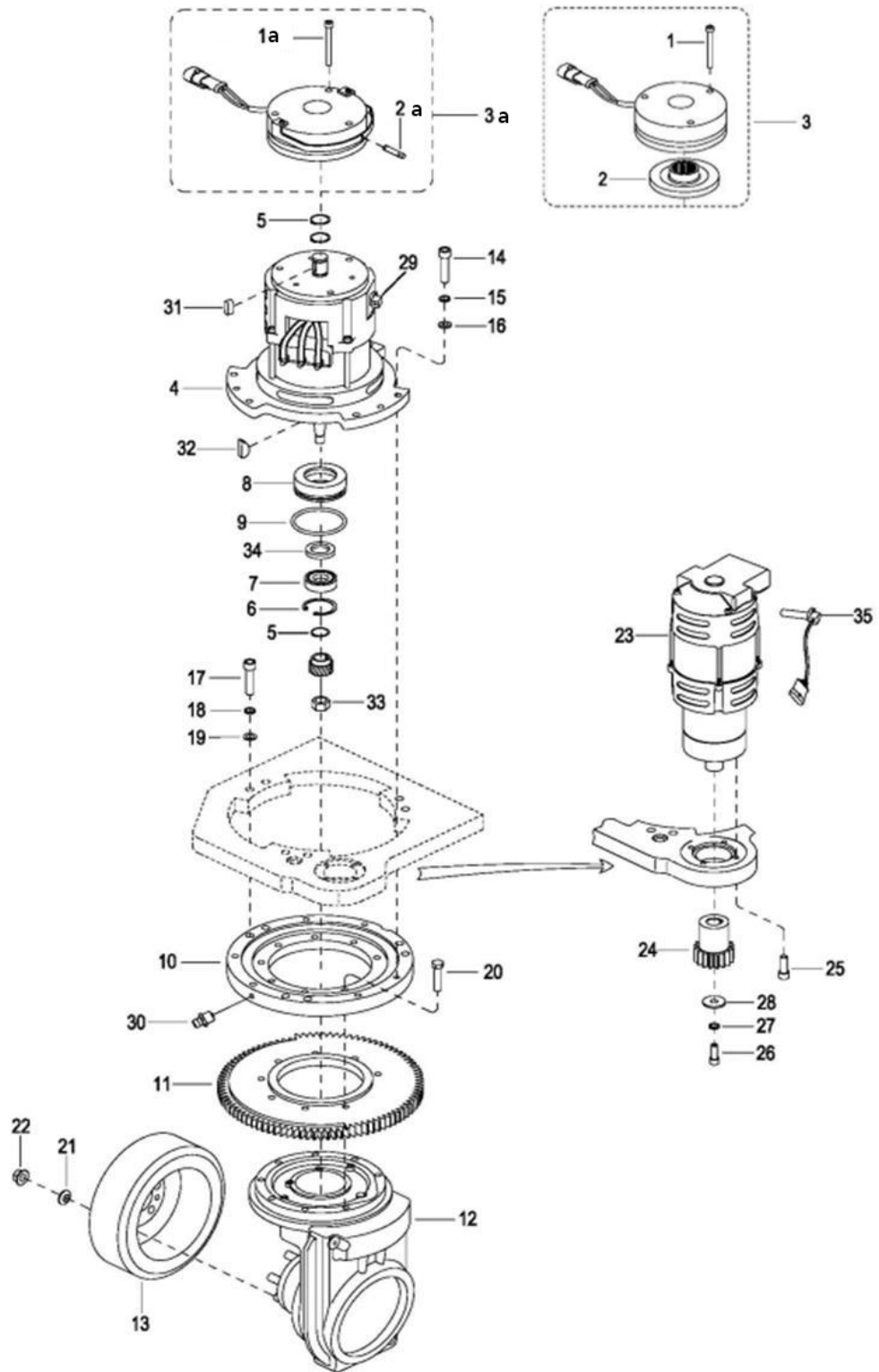

R8161

Figure 11-7 Transmission, Motor & Brake Assembly

Transmission, Motor & Brake Assembly

| POS. | PART NUMBER | DESCRIPTION | QTY. REQD. | NOTES |
|------|----------------|--------------------------|------------|------------------------------------|
| 1 | 0000-001129-10 | SCREW M5×45 | 3 | Used up to Serial Number 224190036 |
| 1a | CK10-250002-20 | SCREW M5×55 | 3 | Used from Serial Number 224190037 |
| 2 | CK10-250001-10 | ROD | 1 | Used up to Serial Number 224190036 |
| 2a | CK10-250003-20 | ROD | 1 | Used from Serial Number 224190037 |
| 3 | CK10-250000-10 | BRAKE | 1 | Used up to Serial Number 224190036 |
| 3a | CK10-250000-20 | BRAKE | 1 | Used from Serial Number 224190037 |
| 4 | CK10-220000-10 | DRIVE MOTOR | 1 | |
| 5 | 0000-000293-00 | RETAINER RING Ø20 | 3 | |
| 6 | 0000-000849-00 | SNAP RING Ø47 | 1 | |
| 7 | CK10-220002-10 | BALL BEARING | 1 | |
| 8 | CK10-220003-10 | HUB FOR ENDSHIELD | 1 | |
| 9 | CK10-220004-10 | O-RING Ø64.5×3.0 | 1 | |
| 10 | 1221-230000-00 | BEARING | 1 | |
| 11 | 1221-200003-00 | GEAR | 1 | |
| 12 | 1120-240000-10 | GEAR CASE ASSEMBLY | 1 | |
| 13 | 1120-200001-00 | DRIVE WHEEL | 1 | |
| 14 | 0000-000154-00 | SCREW M8×35 | 6 | |
| 15 | 0000-000159-00 | LOCK WASHER Ø8 | 6 | |
| 16 | 0000-000176-00 | FLAT WASHER Ø8 | 6 | |
| 17 | 0000-000155-00 | SCREW M10×40 | 6 | |
| 18 | 0000-000063-00 | LOCK WASHER Ø10 | 6 | |
| 19 | 0000-000007-00 | FLAT WASHER Ø10 | 6 | |
| 20 | 0000-000869-00 | BOLT M8×40 | 8 | |
| 21 | 0000-000025-00 | LOCK WASHER Ø12 | 5 | |
| 22 | 0000-001131-10 | NUT M12×1.5 | 5 | |
| 23 | CK10-240000-20 | STEERING MOTOR | 1 | |
| 24 | CK10-200001-10 | GEAR | 1 | |
| 25 | 0000-000321-00 | SCREW M8×20 | 4 | |
| 26 | 0000-000386-00 | SCREW M6×20 | 1 | |
| 27 | 0000-000056-00 | LOCK WASHER Ø6 | 1 | |
| 28 | CK10-200002-10 | WASHER | 1 | |
| 29 | CK10-220005-10 | KB-SENSOR | 1 | |
| 30 | 0000-000013-00 | GREASE FITTING M8 | 1 | |
| 31 | 0000-000226-00 | KEY 6×6×16 | 1 | |
| 32 | 0000-000204-00 | KEY 3×5×13 | 1 | |
| 33 | 0000-000436-00 | NUT M12×1.5 | 1 | |
| 34 | CK10-220001-10 | SHAFT SEAL Ø25×40×7 | 1 | |
| 35 | CK10-240001-20 | KB-SENSOR,STEERING MOTOR | 1 | |

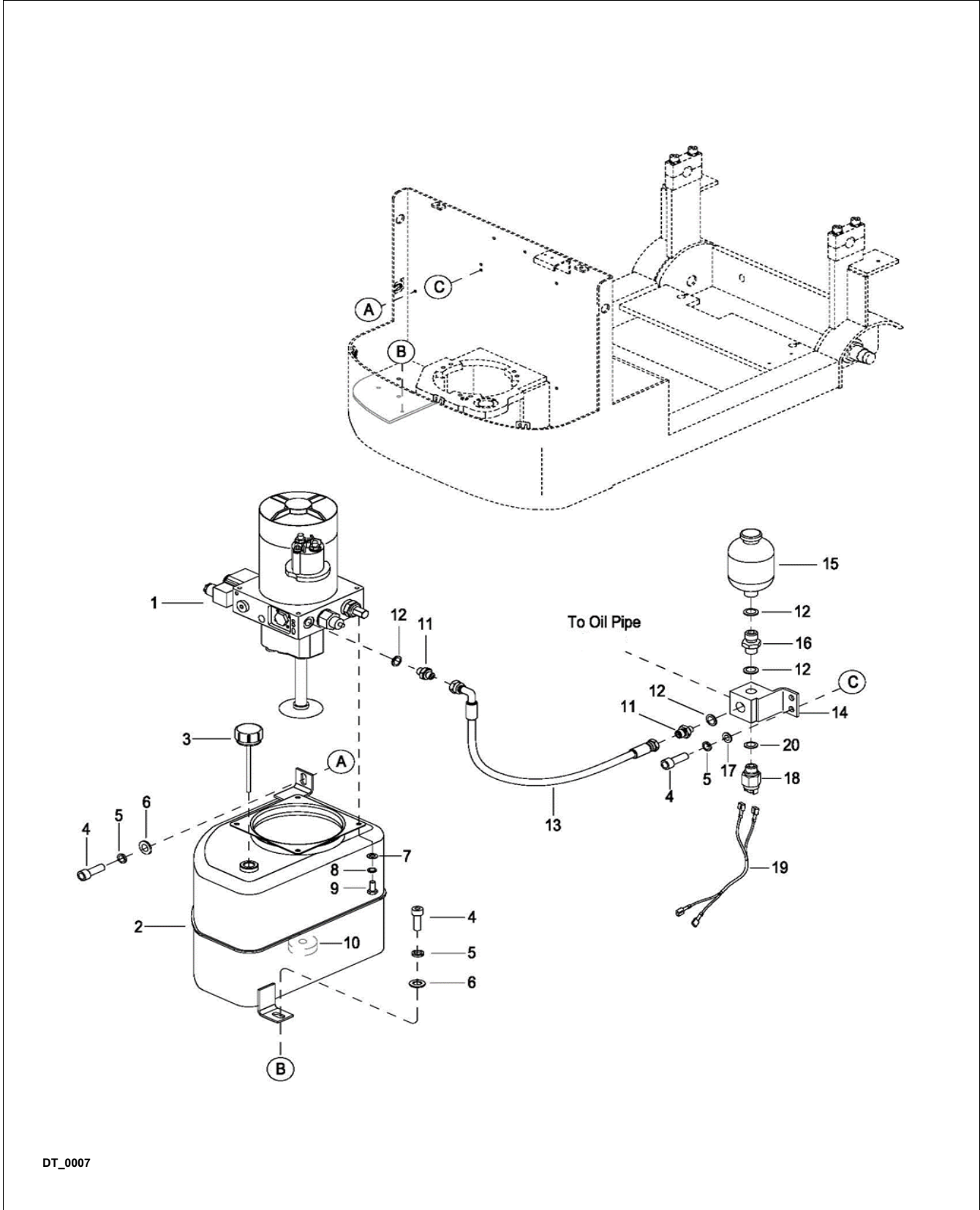

DT_0007

Figure 11-8 Hydraulic System

Hydraulic System

| POS. | PART NUMBER | DESCRIPTION | QTY. REQD. | NOTES |
|------|----------------|---------------------------|------------|------------------------------------|
| 1 | CK10-490000-30 | HYDRAULIC PUMP ASSEMBLY | 1 | |
| 2 | CK11-131000-60 | TANK | 1 | Used up to Serial Number 227160107 |
| 2a | CK11-131000-20 | TANK | 1 | Used from Serial Number 227160108 |
| 3 | CK10-400002-30 | AIR FILTER | 1 | Used up to Serial Number 227180209 |
| 3a | CK10-423000-30 | AIR FILTER | 1 | Used from Serial Number 227180210 |
| 4 | 0000-000433-00 | SCREW M8×12 | 4 | |
| 5 | 0000-000159-00 | LOCK WASHER Ø8 | 4 | |
| 6 | 0000-000194-00 | FLAT WASHER Ø8 | 2 | |
| 7 | 0000-000380-00 | FLAT WASHER Ø6 | 4 | |
| 8 | 0000-000056-00 | LOCK WASHER Ø6 | 4 | |
| 9 | 0000-000620-00 | BOLT M6×16 | 4 | |
| 10 | 2125-420001-00 | MAGNET | 1 | |
| 11 | 2702-141600-00 | CONNECTOR G1/4-M16×1.5 | 2 | |
| 12 | 0000-000044-00 | WASHER Ø14 | 4 | |
| 13 | CK10-480000-30 | OIL PIPE | 1 | |
| 14 | 2112-440000-10 | BLOCK CROSS | 1 | Used up to Serial Number 225180128 |
| 14a | CK10-404000-30 | BLOCK CROSS | 1 | Used from Serial Number 225180129 |
| 15 | CK11-450000-00 | ACCUMULATOR | 1 | |
| 16 | 2701-141400-00 | CONNECTOR M14×1.5-M14×1.5 | 1 | |
| 17 | 0000-000176-00 | FLAT WASHER Ø8 | 2 | |
| 18 | CK10-403000-30 | PRESSURE SWITCH | 1 | |
| 19 | CK10-520021-00 | PRESSURE SWITCH WIRING | 1 | Used from Serial Number 225180129 |
| 20 | 0000-001674-00 | WASHER Ø12 | 1 | |

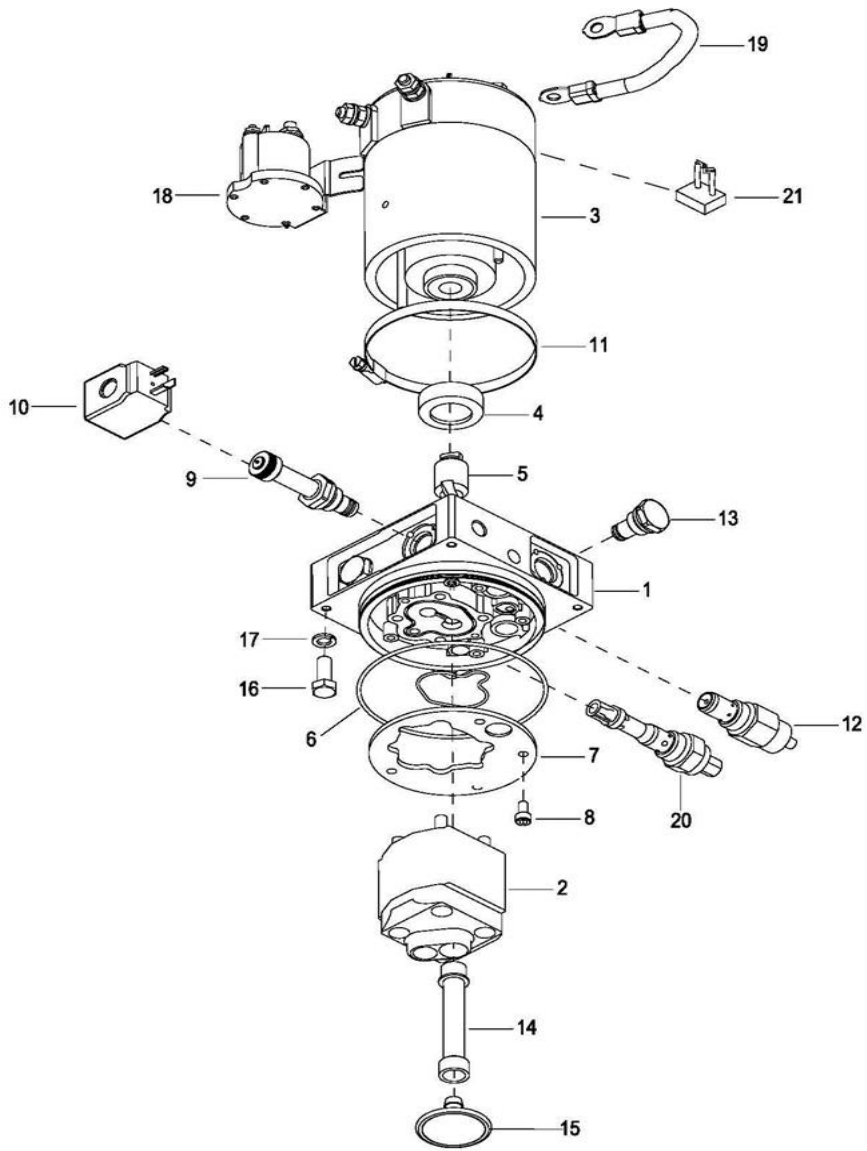

R8166

Figure 11-9 Hydraulic Pump and Motor Assembly

Hydraulic Pump and Motor Assembly

| POS. | PART NUMBER | DESCRIPTION | QTY. REQD. | NOTES |
|------|----------------|-------------------|------------|-------|
| 1 | 2125-430001-00 | ADAPTER | 1 | |
| 2 | CK10-490001-30 | PUMP | 1 | |
| 3 | 2125-430003-00 | MOTOR | 1 | |
| 4 | 2125-430004-00 | BUSHING | 1 | |
| 5 | 2125-430005-00 | COUPLING | 1 | |
| 6 | 2125-430006-00 | SEAL KIT | 1 | |
| 7 | 2125-430007-00 | FILTER SCREEN | 1 | |
| 8 | 0000-000077-00 | SCREW M6×12 | 4 | |
| 9 | CK10-490002-30 | RELEASE VALVE | 1 | |
| 10 | 2125-430010-00 | SOLENOID VALVE | 1 | |
| 11 | 2125-430022-00 | STEEL CLAMP | 1 | |
| 12 | CK10-490003-30 | VALVE | 1 | |
| 13 | 2125-430013-00 | VALVE CAVITY PLUG | 1 | |
| 14 | 2130-430008-0A | PLASTIC TUBE | 2 | |
| 15 | 2130-430009-0A | FILTER | 1 | |
| 16 | 0000-000620-00 | BOLT M6X16 | 4 | |
| 17 | 0000-000056-00 | LOCK WASHER Ø6 | 4 | |
| 18 | 1120-420017-00 | CONTACTOR | 1 | |
| 19 | 2130-430007-0A | CABLE INSULATED | 1 | |
| 20 | CK10-490004-30 | RELIEF VALVE | 1 | |
| 21 | 2125-430023-00 | BRUSH | 2 | |

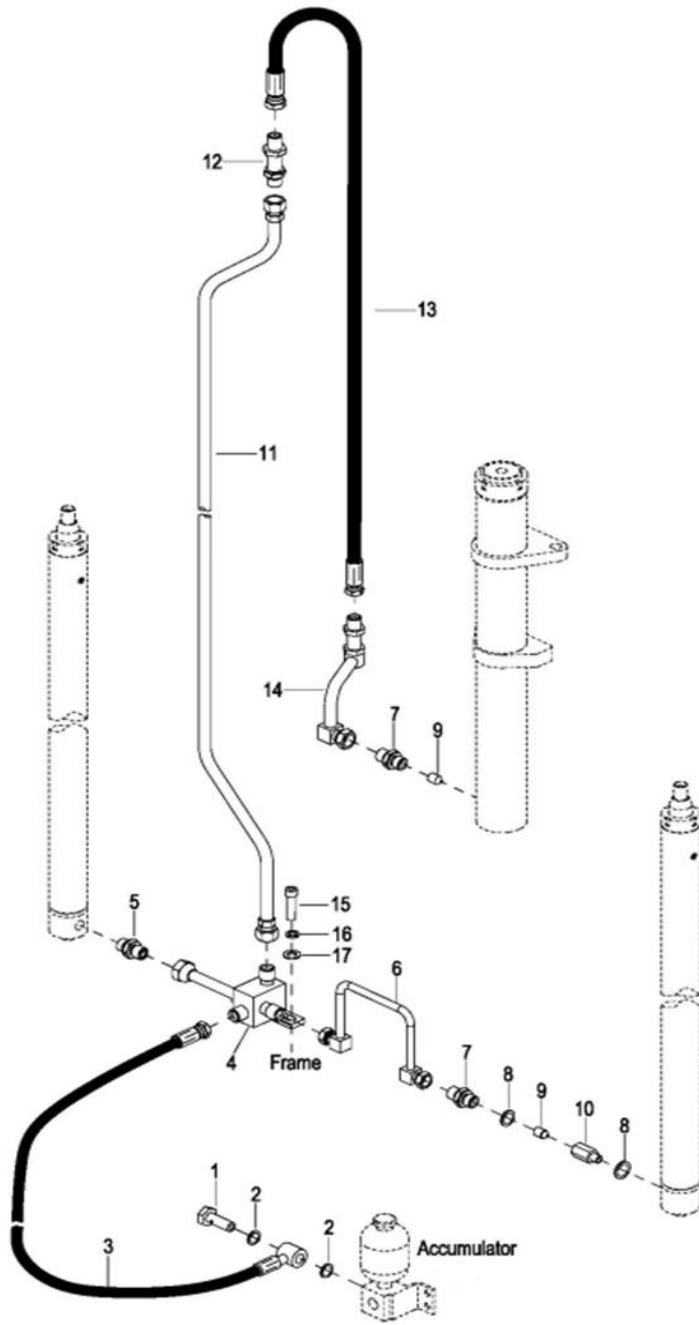

R8176

Figure 11-10 Hydraulic Lines

Hydraulic Lines

| POS. | PART NUMBER | DESCRIPTION | QTY. REQD. | NOTES |
|------|----------------|---------------------------|------------|--|
| 1 | 2402-143500-00 | BOLT G1/4×35 | 1 | |
| 2 | 0000-000044-00 | WASHER Ø14 | 2 | |
| 3 | CK10-436000-60 | OIL PIPE | 1 | |
| 4 | CK10-431000-60 | BLOCK CROSS | 1 | |
| 5 | 2701-161600-00 | CONNECTOR M16×1.5-M16×1.5 | 1 | |
| 6 | CK10-437000-60 | METALLIC OIL PIPE | 1 | |
| 7 | 2702-381600-10 | CONNECTOR G3/8-M16×1.5 | 2 | |
| 8 | 0000-000069-00 | WASHER Ø16 | 2 | |
| 9 | CK10-402000-00 | EXPLOSION RELIEF VALVE | 2 | |
| 10 | CK10-400001-3B | CONNECTOR M16×1.5-G3/8 | 1 | |
| 11 | CK10-433000-60 | METALLIC OIL PIPE II | 1 | |
| 12 | CK10-434000-60 | CONNECTOR M16×1.5-M16×1.5 | 1 | |
| 13 | CK10-435000-60 | HOSE | 1 | |
| 14 | CK10-432000-60 | METALLIC OIL PIPE I | 1 | Used up to Serial number 2281200213 |
| 14a | CK10-432000-6A | METALLIC OIL PIPE I | 1 | Used from Serial number 2281200214 |
| 15 | 0000-000321-00 | SCREW M8×20 | 2 | |
| 16 | 0000-000159-00 | LOCK WASHERLOCK WASHER Ø8 | 2 | |
| 17 | 0000-000176-00 | FLAT WASHER Ø8 | 2 | |

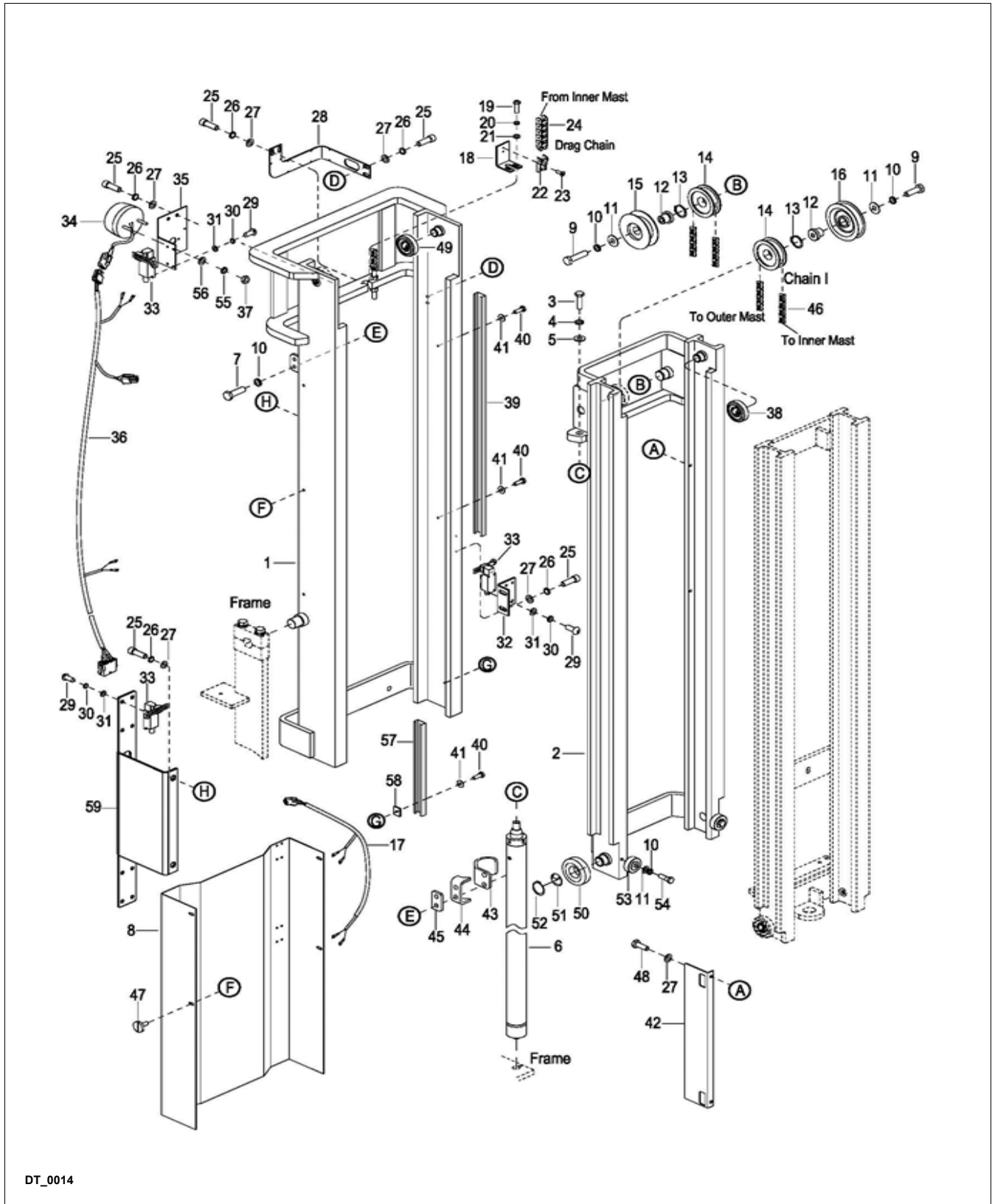

DT_0014

Figure 11-11 Elevation System - Part 1

Elevation System - Part 1

| POS. | PART NUMBER | DESCRIPTION | QTY. REQD. | NOTES |
|------|-------------------|-------------------------------|------------|--|
| 1 | CK10-610000-60 | OUTER MAST | 1 | Used up to Serial number 225180154 |
| 1a | CK10-610000-70 | OUTER MAST | 1 | Used between Serial number 225180155 - 226210149 |
| 1b | CK10-610000-6F | OUTER MAST | 1 | Used from Serial number 226210150 |
| 2 | CK10-620000-60 | MIDDLE MAST | 1 | Used up to Serial number 225180154 |
| 2a | CK10-620000-70 | MIDDLE MAST | 1 | Used from Serial number 225180155 |
| 3 | 0000-000731-00 | BOLT M10×25 | 2 | |
| 4 | 0000-000063-00 | LOCK WASHER Ø10 | 2 | |
| 5 | 0000-000175-00 | FLAT WASHER Ø10 | 2 | |
| 6 | CK10-410000-3A-04 | LIFT CYLINDER | 2 | Used up to Serial # 2281500212 |
| 6a | CK10-410000-3B-04 | LIFT CYLINDER | 2 | Used from Serial # 2281500213 |
| 7 | 0000-000283-00 | BOLT M10×35 | 4 | |
| 8 | CK10-600001-60 | SEAL PLATE | 1 | |
| 9 | 0000-000613-00 | BOLT M12×50 | 2 | |
| 10 | 0000-000060-00 | LOCK WASHER Ø12 | 8 | |
| 11 | 0000-000438-00 | FLAT WASHER Ø12 | 4 | |
| 12 | 2125-600003-30 | BUSHING | 2 | |
| 13 | 0000-000183-00 | RETAINER RING Ø35 | 2 | |
| 14 | 2214-600001-00 | CHAIN ROLLER | 2 | |
| 15 | CK10-600001-30 | NYLON WHEEL I | 1 | Used up to Serial number 226160080 |
| 15a | CK10-600005-3A | NYLON WHEEL I | 1 | Used from Serial number 226160081 |
| 16 | 2125-600002-30 | ROLLER | 1 | Used up to Serial number 226160080 |
| 16a | 2125-600002-3B | ROLLER | 1 | Used from Serial number 226160081 |
| 17 | CK10-520022-60 | SWITCH COMMUNICATION WIRING | 1 | |
| 18 | CK10-500001-60 | DRAG CHAIN MOUNTING PLATE | 1 | Used up to Serial number 226200269 |
| 18a | CK10-500001-6A | DRAG CHAIN MOUNTING PLATE | 1 | Used from Serial number 226200270 |
| 19 | 0000-000618-00 | SCREW M6×12 | 2 | |
| 20 | 0000-000056-00 | LOCK WASHER Ø6 | 2 | |
| 21 | 0000-000380-00 | FLAT WASHER Ø6 | 2 | |
| 22 | CK10-510005-00 | DRAG HEAD II | 1 | |
| 23 | 0000-000416-00 | SCREW M4×8 | 2 | |
| 24 | CK10-510003-00-11 | DRAG CHAIN II | 1 | |
| 25 | 0000-000109-00 | SCREW M8×16 | 8 | |
| 26 | 0000-000159-00 | LOCK WASHER Ø8 | 8 | |
| 27 | 0000-000176-00 | FLAT WASHER Ø8 | 10 | |
| 28 | CK10-600005-60 | BOARD | 1 | |
| 29 | 0000-000381-00 | SCREW M5×10 | 16 | |
| 30 | 0000-000206-00 | LOCK WASHER Ø5 | 16 | |
| 31 | 0000-000390-00 | FLAT WASHER Ø5 | 16 | |
| 32 | CK10-600004-6A | FIXED PLATE I | 1 | |
| 33 | 2125-500003-00 | PROXIMITY SWITCH | 4 | |
| 34 | CK10-520015-00 | WARNING LAMP | 1 | Used up to Serial Number 225170105 |
| 34a | CK10-520015-10 | WARNING LAMP | 1 | Used from Serial Number 225170106 |
| 35 | CK10-600002-60 | BOARD | 1 | |
| 36 | CK10-520016-60 | SWITCH WIRING OF TRIPLEX MAST | 1 | |
| 37 | 0000-000998-00 | SCREW M3×8 | 2 | Used up to Serial Number 225170105 |
| 37a | 0000-000139-00 | NUT M4 | 2 | Used from Serial Number 225170106 |

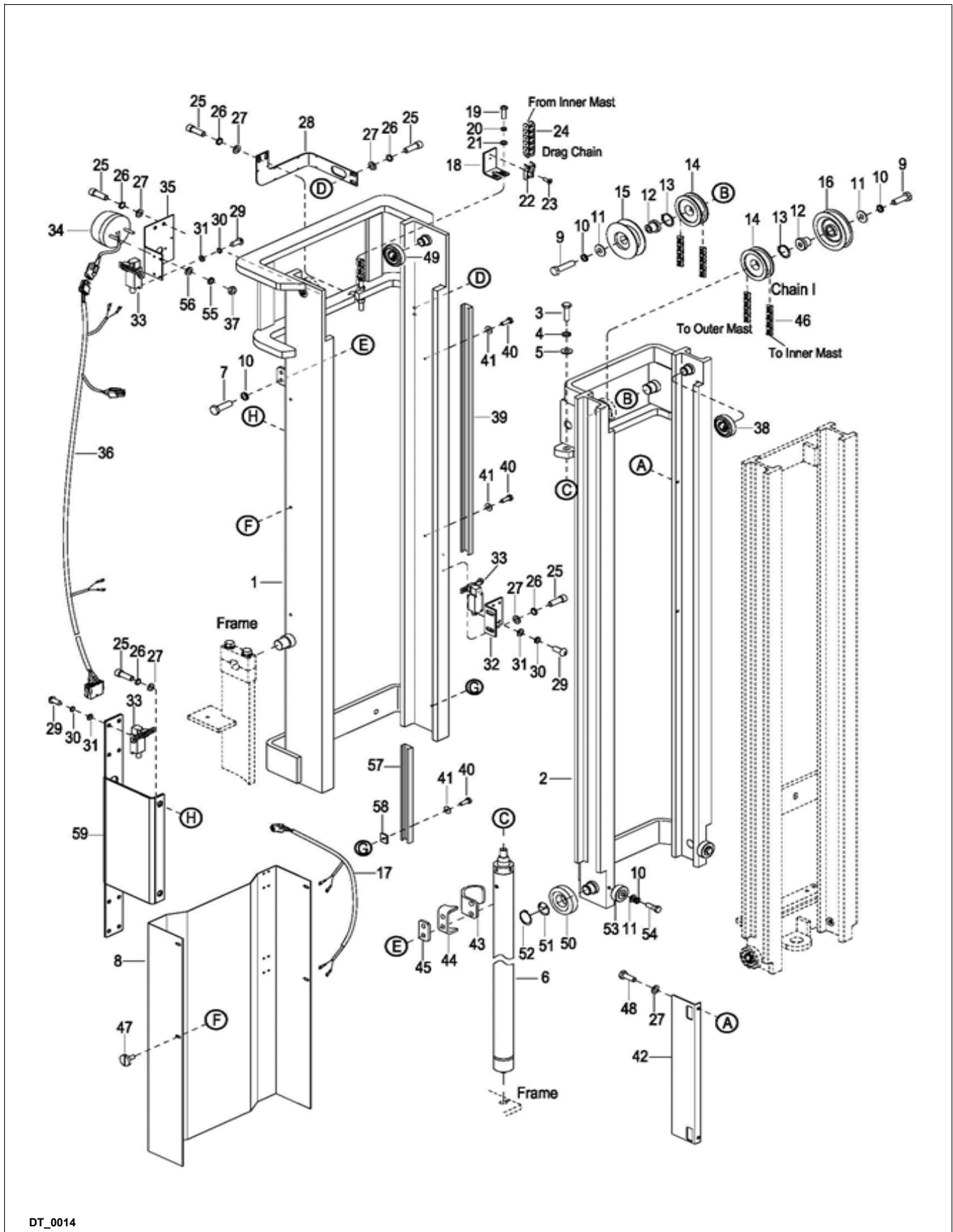
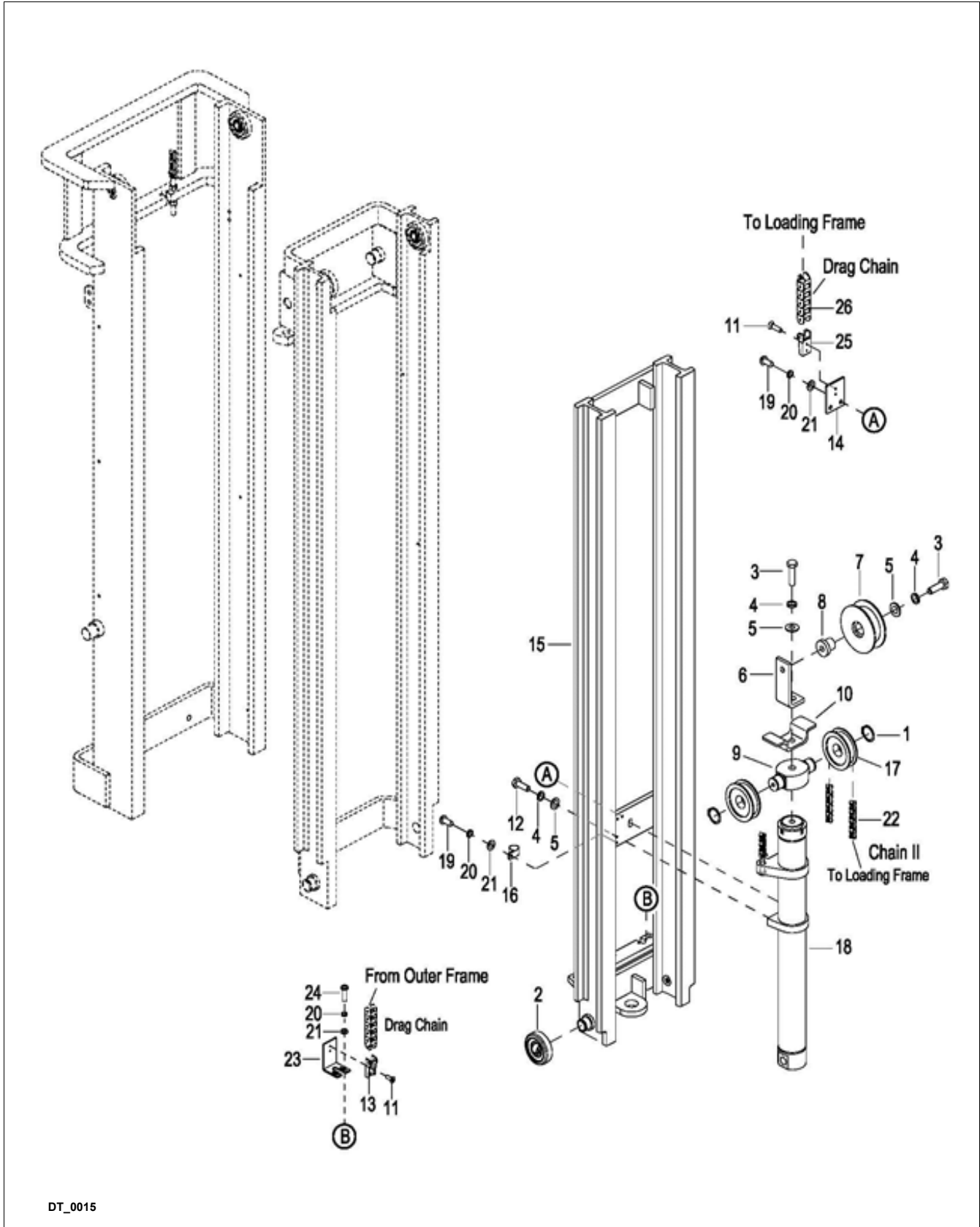

Figure 11-11 Elevation System - Part 1 - Continued

Elevation System - Part 1 - Continued

| POS. | PART NUMBER | DESCRIPTION | QTY. REQD. | NOTES |
|------|-------------------|------------------|------------|--|
| 38 | 2125-612000-00 | ROLLER ASSEMBLY | 2 | Used up to Serial number 225180154 - (78.3-12S) |
| 38a | CK10-613000-00 | ROLLER ASSEMBLY | 2 | Used from Serial number 225180155 - (79.8-1S-00) |
| 39 | CK11-700003-00 | WIRE GROOVE | 1 | |
| 40 | 0000-000275-00 | BOLT M6×30 | 2 | |
| 41 | 0000-000123-00 | FLAT WASHER Ø6 | 2 | |
| 42 | CK10-600003-60 | PLATE | 1 | |
| 43 | CK10-600007-60 | CYLINDER CLIP | 2 | |
| 44 | CK10-600006-60 | CYLINDER SUPPORT | 2 | |
| 45 | 2214-600007-00 | CUSHION BLOCK II | A.R. | As Required |
| 46 | CK10-650000-30-04 | CHAIN I | 2 | Used up to Serial Number 227160164 |
| 46a | CK10-650000-60 | CHAIN I | 2 | Used from Serial Number 227160165 |
| 47 | 0000-000368-00 | SCREW M8×12 | 4 | |
| 48 | 0000-000129-00 | BOLT M8×10 | 2 | |
| 49 | 2125-612000-00 | ROLLER ASSEMBLY | 2 | Used up to Serial number 225180154 - (78.3-12S) |
| 49a | CK10-613000-00 | ROLLER ASSEMBLY | 2 | Used from Serial number 225180155 - (79.8-1S-00) |
| 50 | 2415-612000-10 | ROLLER ASSEMBLY | 2 | Used up to serial number 225100040 - 109.2-2TS |
| 50a | 3315-522001-00 | ROLLER | 2 | Used from serial number 225100041 |
| 51 | 3315-522004-00 | DUST RING | 2 | |
| 52 | 3315-522003-00 | SHAFT RING | 2 | |
| 53 | CK10-640000-60 | ROLLER | 2 | |
| 54 | 0000-000593-00 | BOLT M12×40 | 2 | |
| 55 | 0000-000122-00 | LOCKWASHER Ø4 | 2 | Used from serial number 225170106 |
| 56 | 0000-000702-00 | FLATWASHER Ø4 | 2 | Used from serial number 225170106 |
| 57 | CK10-510034-60 | WIRE GROOVE | 1 | Used from serial number 226210150 |
| 58 | CK10-510035-60 | PLATE | 2 | |
| 59 | CK10-600008-60 | COVER | 2 | Used from serial number 226210148 |



DT_0015

Figure 11-12 Elevation System - Part 2

Elevation System - Part 2

| POS. | PART NUMBER | DESCRIPTION | QTY. REQD. | NOTES |
|------|-------------------|-----------------------------|------------|--|
| 1 | 0000-000183-00 | RETAINER RING Ø35 | 2 | |
| 2 | 2125-612000-00 | ROLLER ASSEMBLY | 2 | Used up to Serial number 225180154 - (78.3-12S) |
| 2a | CK10-613000-00 | ROLLER ASSEMBLY | 2 | Used from Serial number 225180155 - (79.8-1S-00) |
| 3 | 0000-000613-00 | BOLT M12×50 | 2 | |
| 4 | 0000-000060-00 | LOCK WASHER Ø12 | 4 | |
| 5 | 0000-000438-00 | FLAT WASHER Ø12 | 4 | |
| 6 | CK10-600004-30 | FIXED ANGLE | 1 | |
| 7 | CK10-600005-30 | NYLON WHEEL II | 1 | Used up to Serial number 226160080 |
| 7a | CK10-600005-3A | NYLON WHEEL II | 1 | Used from Serial number 226160081 |
| 8 | 2125-600003-30 | BUSHING | 1 | |
| 9 | CK10-600006-30 | ROLLER BRACKET | 1 | |
| 10 | 2125-600007-3B | CHAIN BRACKET | 1 | |
| 11 | 0000-000416-00 | SCREW M4×8 | 4 | |
| 12 | 0000-000285-00 | BOLT M12×35 | 2 | |
| 13 | CK10-510004-00 | DRAG HEAD I | 1 | |
| 14 | CK10-510011-0A | DRAG CHAIN MOUNTING PLATE | 1 | |
| 15 | CK10-630000-60 | INNER MAST | 1 | Used up to Serial number 225180154 |
| 15a | CK10-630000-70 | INNER MAST | 1 | Used from Serial number 225180155 |
| 16 | 0000-001058-00 | HARNESS CLAMP | 2 | |
| 17 | 2214-600001-00 | CHAIN ROLLER | 2 | |
| 18 | CK10-420000-3A-04 | FREE LIFT CYLINDER ASSEMBLY | 1 | Used up to Serial number 2281200213 |
| 18a | CK10-420000-3B-04 | FREE LIFT CYLINDER ASSEMBLY | 1 | Used from Serial number 2281200214 |
| 19 | 0000-000179-00 | SCREW M6×10 | 4 | |
| 20 | 0000-000056-00 | LOCK WASHER Ø6 | 6 | |
| 21 | 0000-000380-00 | FLAT WASHER Ø6 | 6 | |
| 22 | CK10-660000-30-04 | CHAIN ASSEMBLY II | 2 | |
| 23 | CK10-500001-60 | DRAG CHAIN MOUNTING PLATE | 1 | Used up to Serial number 226200269 |
| 23a | CK10-500001-6A | DRAG CHAIN MOUNTING PLATE | 1 | Used from Serial number 226200270 |
| 24 | 0000-000618-00 | SCREW M6×12 | 2 | |
| 25 | CK10-510005-00 | DRAG HEAD II | 1 | |
| 26 | CK10-510003-00-12 | DRAG CHAIN II | 1 | |

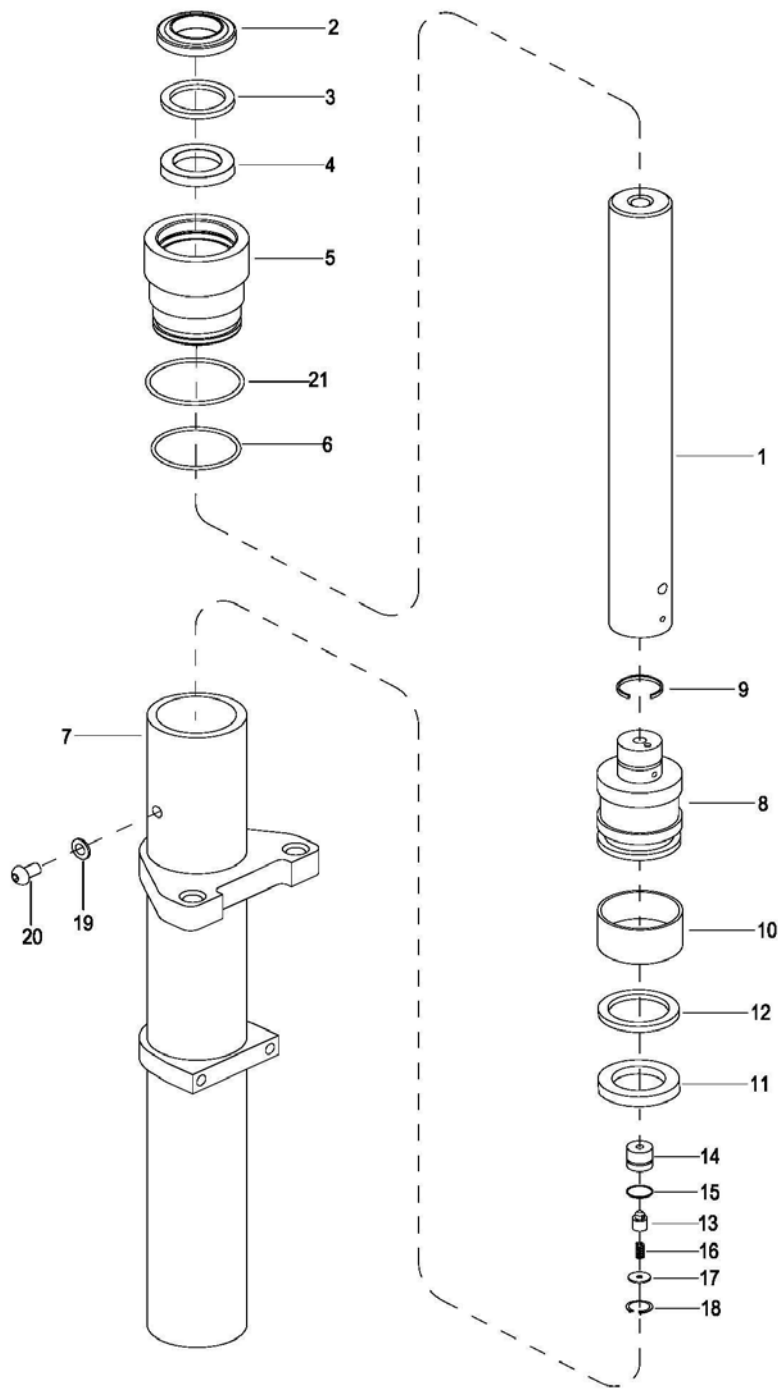

R8177

Figure 11-13 Full Free Lift Cylinder - Used up to Serial number 2281200213

Full Free Lift Cylinder - Used up to Serial number 2281200213

| POS. | PART NUMBER | DESCRIPTION | QTY. REQD. | NOTES |
|------|-------------------|------------------------|------------|-----------------------------|
| -- | CK10-420000-3A-04 | CYLINDER ASSEMBLY | 1 | |
| KIT | CK10-ZZG-3A | SEAL KIT | 1 | Include item 2,4,6,11,15,21 |
| 1 | CK10-420001-3A-04 | PISTON ROD | 1 | |
| 2 | 0000-001087-00 | RING WIPER 50×58×5-6.5 | 1 | |
| 3 | 0000-001088-00 | COLLAR 50×60×2 | 1 | |
| 4 | 0000-001089-00 | ROD PACKING 50×60×6 | 1 | |
| 5 | CK10-420002-3A | CAP | 1 | |
| 6 | 0000-000690-00 | O-RING 60×3.1 | 1 | |
| 7 | CK10-421000-3A-04 | CYLINDER TUBE | 1 | |
| 8 | CK10-420003-3A | PISTON | 1 | |
| 9 | 1280-430004-00 | COLLAR 33×27×3 | 1 | |
| 10 | CK10-420004-3A | RING BACK UP 55×20×2.5 | 1 | |
| 11 | 0000-001091-00 | ROD PACKING 45×55×6 | 1 | |
| 12 | 0000-001090-00 | COLLAR 45×55×2 | 1 | |
| 13 | 3218-420005-30 | RELEASE VALVE | 1 | |
| 14 | 3218-420004-30 | SOLENOID VALVE | 1 | |
| 15 | 0000-000344-00 | O-RING 20×2.4 | 1 | |
| 16 | CK10-420005-3A | SPRING | 1 | |
| 17 | 3218-420006-30 | COLLAR | 1 | |
| 18 | 0000-000607-00 | COLLAR Ø22 | 1 | |
| 19 | 0000-000133-00 | WASHER Ø6 | 1 | |
| 20 | 0000-001137-00 | SCREW M6×5 | 1 | |
| 21 | 0000-000685-00 | O-RING 65×3.1 | 1 | |

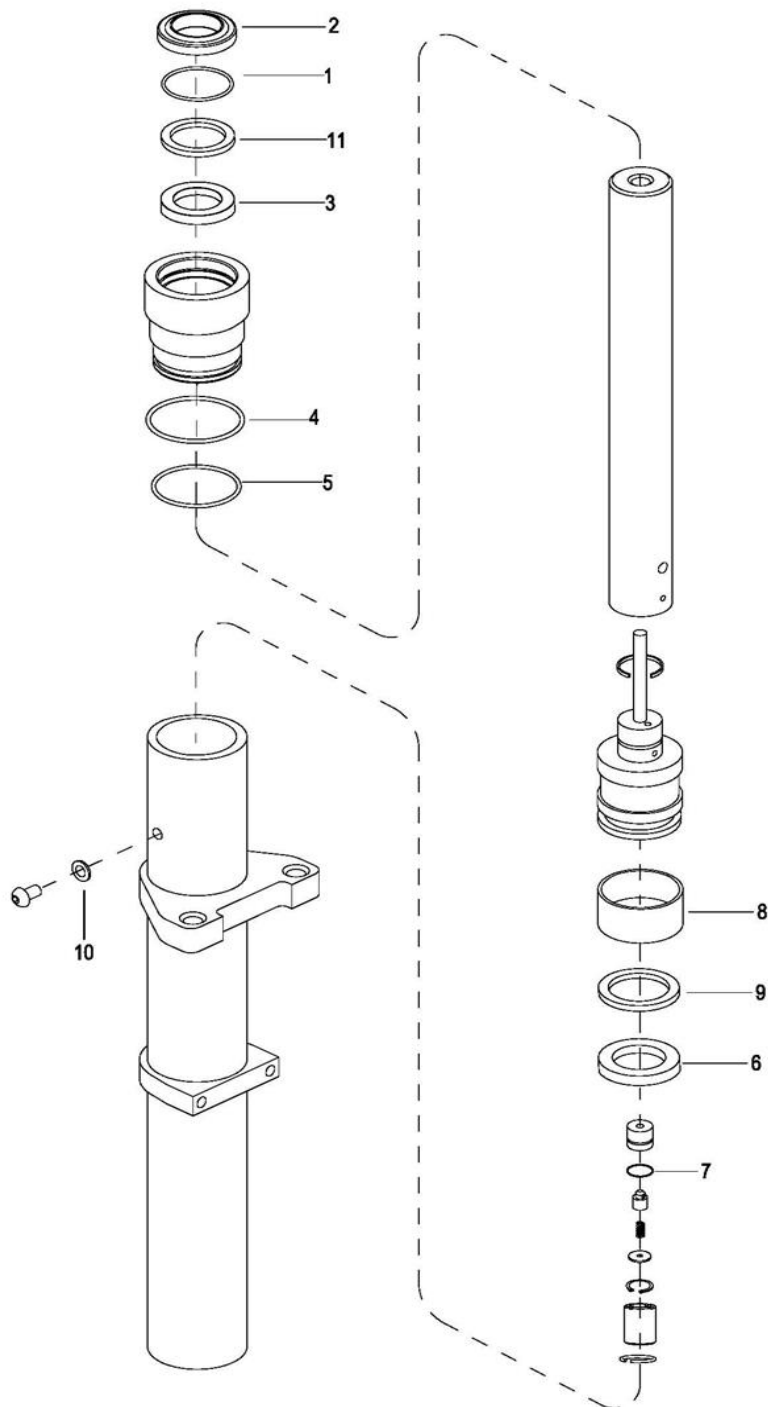

DT_0025

Figure 11-14 Full Free Lift Cylinder - Used from Serial number 2281200214

Full Free Lift Cylinder - Used from Serial number 2281200214

| POS. | PART NUMBER | DESCRIPTION | QTY. REQD. | NOTES |
|------|-------------------|------------------------|------------|--|
| -- | CK10-420000-3B-04 | CYLINDER ASSEMBLY | 1 | |
| KIT | CK10-ZZG-3B | SEAL KIT | 1 | Include items 1,2,3,4,5,6,7,8,9,10,11 |
| 1 | CK10-420001-3A-04 | PISTON ROD | 1 | |
| 2 | 0000-001087-00 | RING WIPER 50×58×5-6.5 | 1 | |
| 3 | 0000-001088-00 | COLLAR 50×60×2 | 1 | |
| 4 | 0000-001089-00 | ROD PACKING 50×60×6 | 1 | |
| 5 | CK10-420002-3A | CAP | 1 | |
| 6 | 0000-000690-00 | O-RING 60×3.1 | 1 | |
| 7 | CK10-421000-3A-04 | CYLINDER TUBE | 1 | |
| 8 | CK10-420003-3A | PISTON | 1 | |
| 9 | 1280-430004-00 | COLLAR 33×27×3 | 1 | |
| 10 | CK10-420004-3A | RING BACK UP 55×20×2.5 | 1 | |
| 11 | 0000-001091-00 | ROD PACKING 45×55×6 | 1 | |
| 12 | 0000-001090-00 | COLLAR 45×55×2 | 1 | |
| 13 | 3218-420005-30 | RELEASE VALVE | 1 | |
| 14 | 3218-420004-30 | SOLENOID VALVE | 1 | |
| 15 | 0000-000344-00 | O-RING 20×2.4 | 1 | |
| 16 | CK10-420005-3A | SPRING | 1 | |
| 17 | 3218-420006-30 | COLLAR | 1 | |
| 18 | 0000-000607-00 | COLLAR Ø22 | 1 | |
| 19 | 0000-000133-00 | WASHER Ø6 | 1 | |
| 20 | 0000-001137-00 | SCREW M6×5 | 1 | |
| 21 | 0000-000685-00 | O-RING 65×3.1 | 1 | |

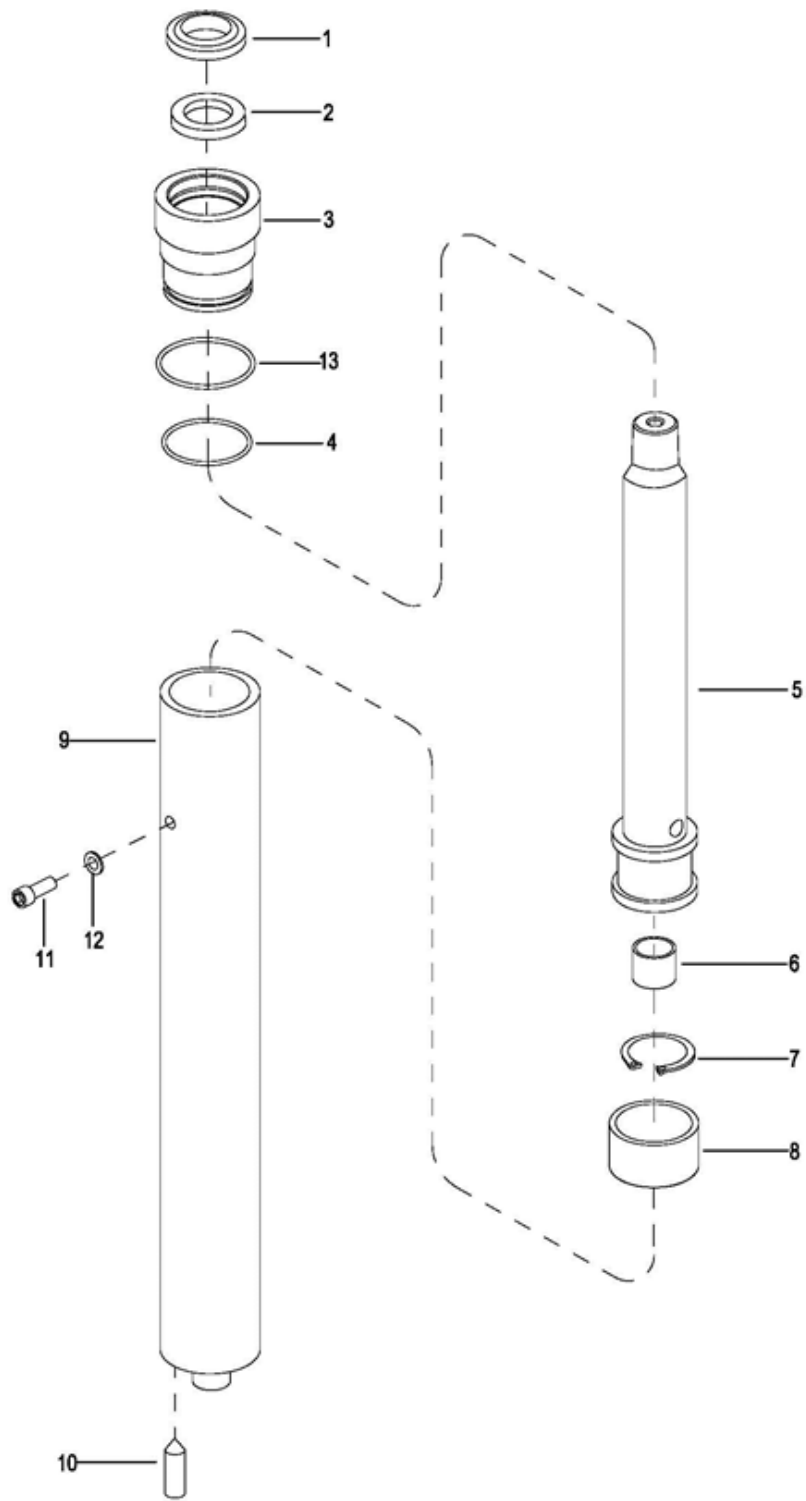

R8179

Figure 11-15 Lift Cylinder (Secondary) - Used up to Serial Number 2281500212

Lift Cylinder (Secondary) - Used up to Serial Number 2281500212

| POS. | PART NUMBER | DESCRIPTION | QTY. REQD. | NOTES |
|------|-------------------|----------------------------|------------|-----------------------------------|
| -- | CK10-410000-3A-04 | CYLINDER ASSEMBLY | 1 | |
| KIT | 2125-ZBG-3A | SEAL KIT FOR LIFT CYLINDER | 1 | Include item1,2,4,13 |
| 1 | 0000-000084-00 | RING WIPER 35×43×5-6.5 | 1 | |
| 2 | 0000-000085-00 | ROD PACKING 35×45×6 | 1 | |
| 3 | 2125-410004-30 | CAP | 1 | |
| 4 | 0000-000519-00 | O-RING 48×3.1 | 1 | |
| 5 | CK10-410001-30-04 | PISTON ROD | 1 | |
| 6 | 2125-410005-3A | BUSHING | 1 | |
| 7 | 0000-000520-00 | COLLAR Ø24 | 1 | |
| 8 | 2125-410002-30 | RING BACK UP | 1 | |
| 9 | CK10-411000-30-04 | CYLINDER | 1 | |
| 10 | 2125-410006-30 | PIN | 1 | Used up to Serial number S2314158 |
| 10a | 3010-020000-16 | BOLT M8×30 | 1 | Used from Serial number S2314159 |
| 11 | 0000-001092-00 | SCREW M6×6 | 1 | |
| 12 | 0000-000133-00 | WASHER Ø6 | 1 | |
| 13 | 0000-000609-00 | O-RING 52.5×3.1 | 1 | |

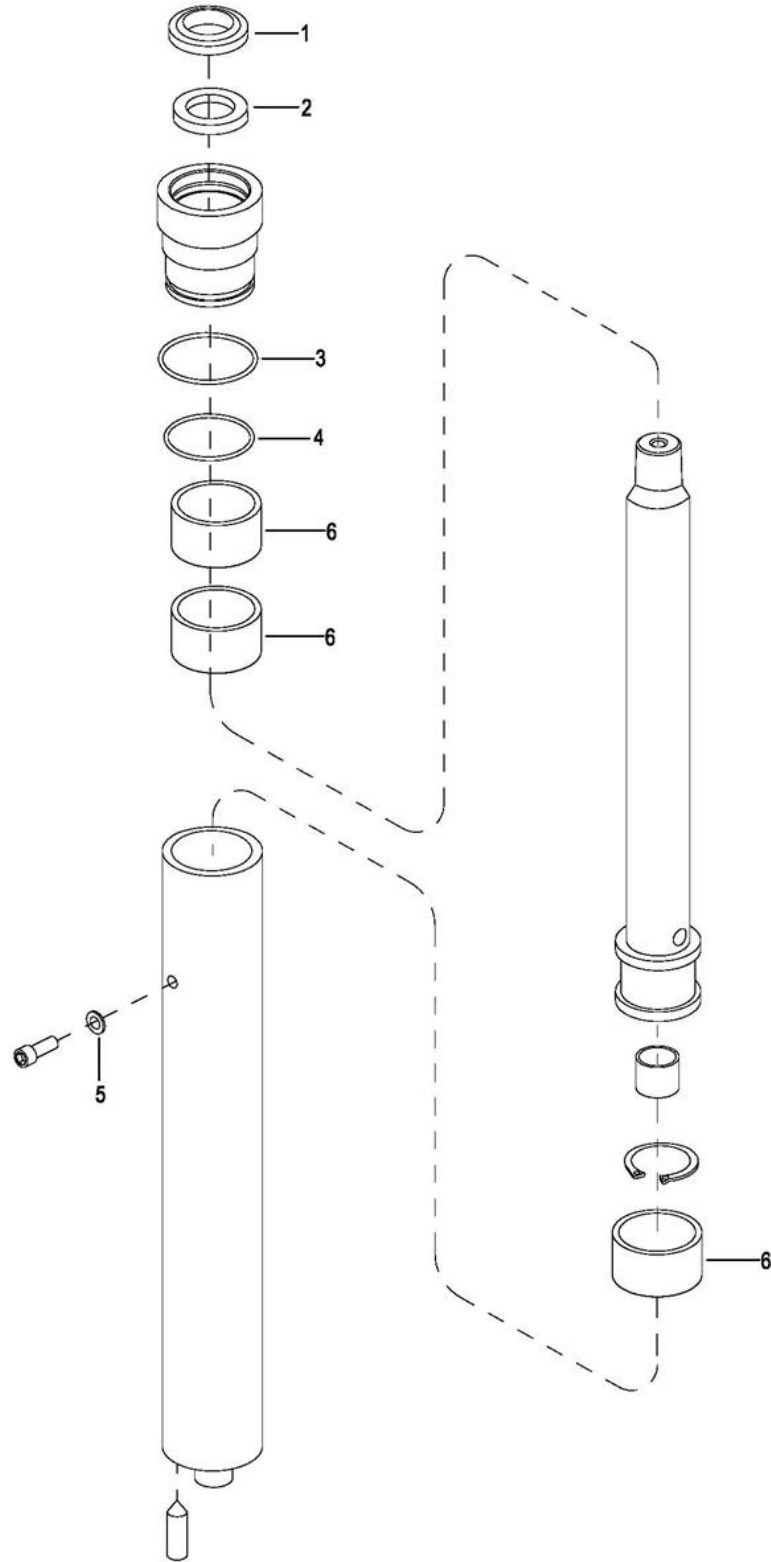

DT_0024

Figure 11-16 Lift Cylinder (Secondary) - Used from Serial Number 2281500213

Lift Cylinder (Secondary) - Used from Serial Number 2281500213

| POS. | PART NUMBER | DESCRIPTION | QTY. REQD. | NOTES |
|------|-------------------|-------------------------------|------------|-------------------------------|
| -- | CK10-410000-3B-01 | LIFT CYLINDER ASSEMBLY | 2 | Used on Lift Height 126" |
| -- | CK10-410000-3B-03 | LIFT CYLINDER ASSEMBLY | 2 | Used on Lift Height 162" |
| 1 | -- | RING WIPER 35×43×5-6.5 | 1 | |
| 2 | -- | ROD PACKING 35×45×6 | 1 | |
| 3 | -- | O-RING 52.5×3.1 | 1 | |
| 4 | -- | O-RING 48×3.1 | 1 | |
| 5 | -- | WASHER Ø6 | 1 | |
| 6 | -- | RING BACK UP | 1 | |
| 7 | CK10-ZBG-3B | SEAL KIT FOR LIFTING CYLINDER | 1 | Includes Item 1, 2, 3,4,5 & 6 |

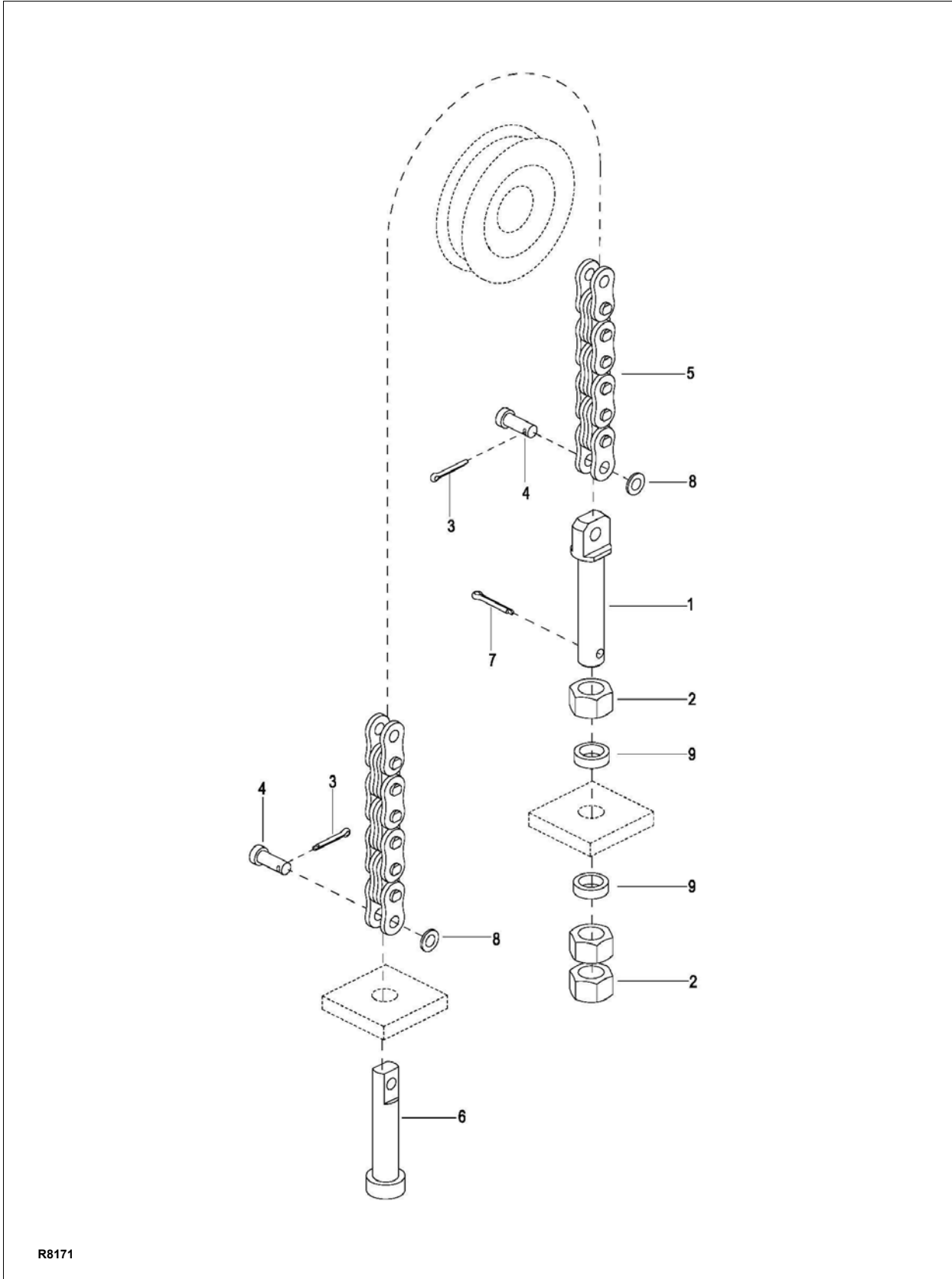

R8171

Figure 11-17 Chain Assembly

Chain Assembly

| POS. | PART NUMBER | DESCRIPTION | QTY. REQD. | NOTES |
|------|-------------------|-----------------------|------------|---|
| 1 | 2125-640001-00 | BOLT | 1 | |
| 2 | 0000-000187-00 | NUT M16×1.5 | 3 | Used up to Serial Number 226170084 |
| 2a | 3030-250000-01 | SPHERICAL NUT M16×1.5 | 2 | Used from Serial Number 226170085 - Only use the two bottom nuts. |
| 3 | 3070-010000-12 | COTTER PIN Ø2.5×30 | 2 | |
| 4 | 2125-640002-00 | PIN | 2 | |
| 5 | CK10-650000-30-04 | LIFT CHAIN I | 1 | Used up to Serial Number 227160164 - For Lifting Mast |
| 5a | CK10-650000-60 | LIFT CHAIN I | 1 | Used from Serial Number 227160165 - For Lifting Mast |
| 5b | CK10-660000-30-04 | LIFT CHAIN II | 1 | For platform |
| 6 | 2125-640003-00 | CHAIN ANCHOR | 1 | Used up to Serial Number 227160164 - For Lifting Mast |
| 6a | 2125-640004-00 | CHAIN ANCHOR | 1 | Used from Serial Number 227160165 - For Lifting Mast |
| 6b | 2125-640003-00 | CHAIN ANCHOR | 1 | For platform |
| 7 | 3070-010000-03 | COTTER PIN Ø3.2×40 | 1 | |
| 8 | 0000-000176-00 | FLAT WASHER Ø8 | 2 | |
| 9 | CK10-600007-00 | WASHER | A.R. | As Required |

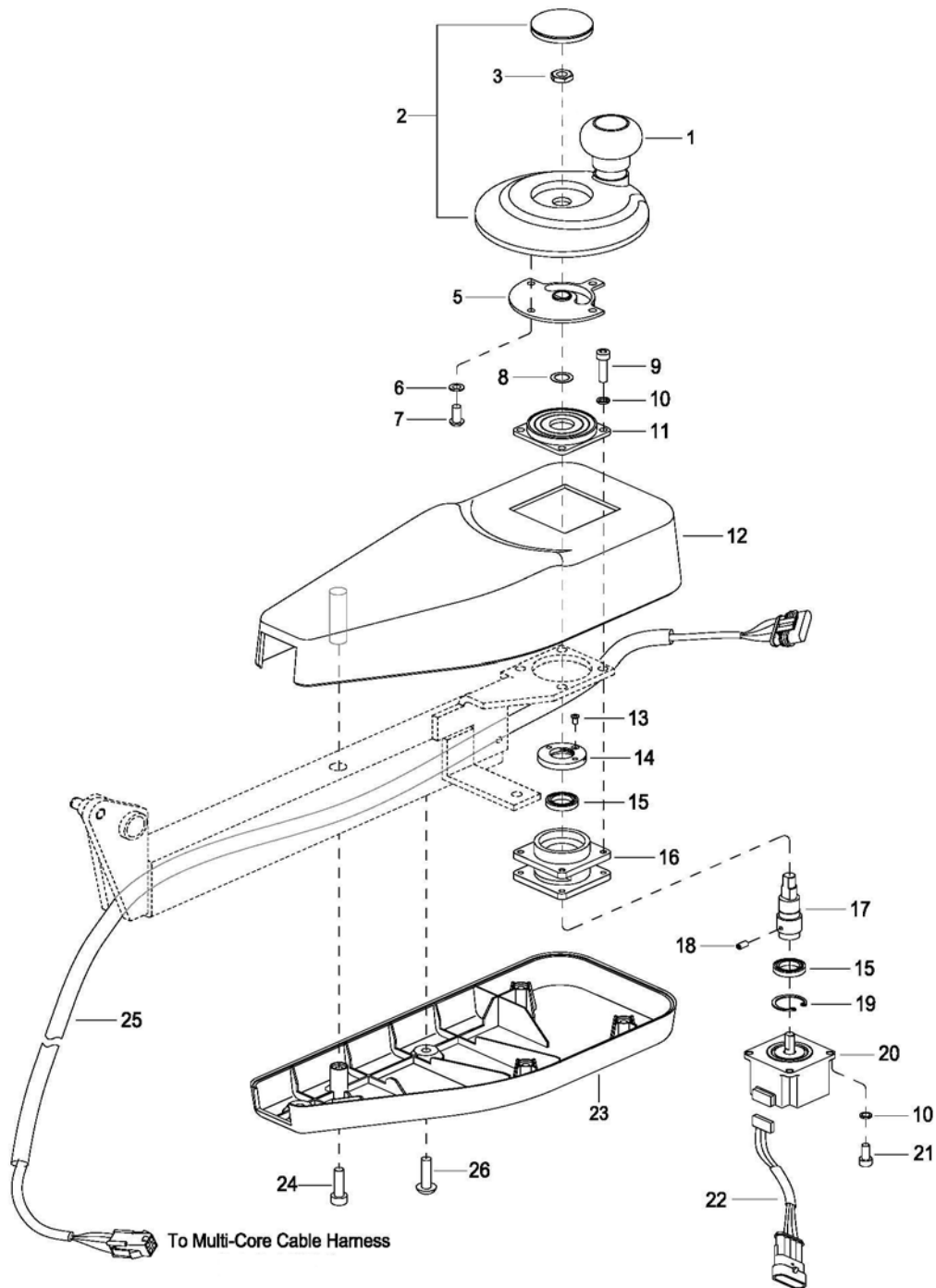

R8163

Figure 11-18 Control Arm (Left)

Control Arm (Left)

| POS. | PART NUMBER | DESCRIPTION | QTY. REQD. | NOTES |
|------|----------------|------------------------------------|------------|-------------|
| 1 | CK11-311000-00 | HANDLE BALL | 1 | |
| 2 | CK11-310002-00 | STEERING WHEEL | 1 | |
| 3 | 0000-000951-00 | NUT M10×1.5 | 1 | |
| 5 | 3316-311202-00 | ROUND BOTTOM | 1 | |
| 6 | 0000-000702-00 | FLAT WASHER Ø4 | 4 | |
| 7 | 0000-000646-00 | SCREW M4×10 | 4 | |
| 8 | 3316-311204-00 | WASHER | A.R. | As Required |
| 9 | 0000-000035-00 | BOLT M5×20 | 4 | |
| 10 | 0000-000206-00 | LOCK WASHER Ø5 | 8 | |
| 11 | 3316-311203-00 | DAMPING STEERING BOX | 1 | |
| 12 | CK11-310003-00 | UPPER COVER OF LEFT ARMREST | 1 | |
| 13 | 0000-000939-00 | SCREW M3×6 | 1 | |
| 14 | 3316-311205-00 | NUT | 1 | |
| 15 | 0000-000937-00 | BEARING | 2 | |
| 16 | 3316-311206-00 | BEARING BLOCK | 1 | |
| 17 | 3316-311201-00 | AXLE | 1 | |
| 18 | 3020-050000-17 | SCREW M5×8 | 1 | |
| 19 | 0000-000941-00 | SNAP RING Ø26 | 1 | |
| 20 | CK11-560002-00 | STEPPING MOTOR | 1 | |
| 21 | 0000-000004-00 | SCREW M5×12 | 4 | |
| 22 | CK11-520007-00 | STEPPING MOTOR WIRE HARNESS | 1 | |
| 23 | CK11-310004-00 | LOWER COVER OF LEFT ARMREST | 1 | |
| 24 | 0000-000661-00 | SCREW M5×20 | 4 | |
| 25 | CK11-520002-00 | WIRE HARNESS OF OPERATION PANEL(L) | 1 | |
| 26 | 0000-000001-00 | SCREW M6×20 | 2 | |

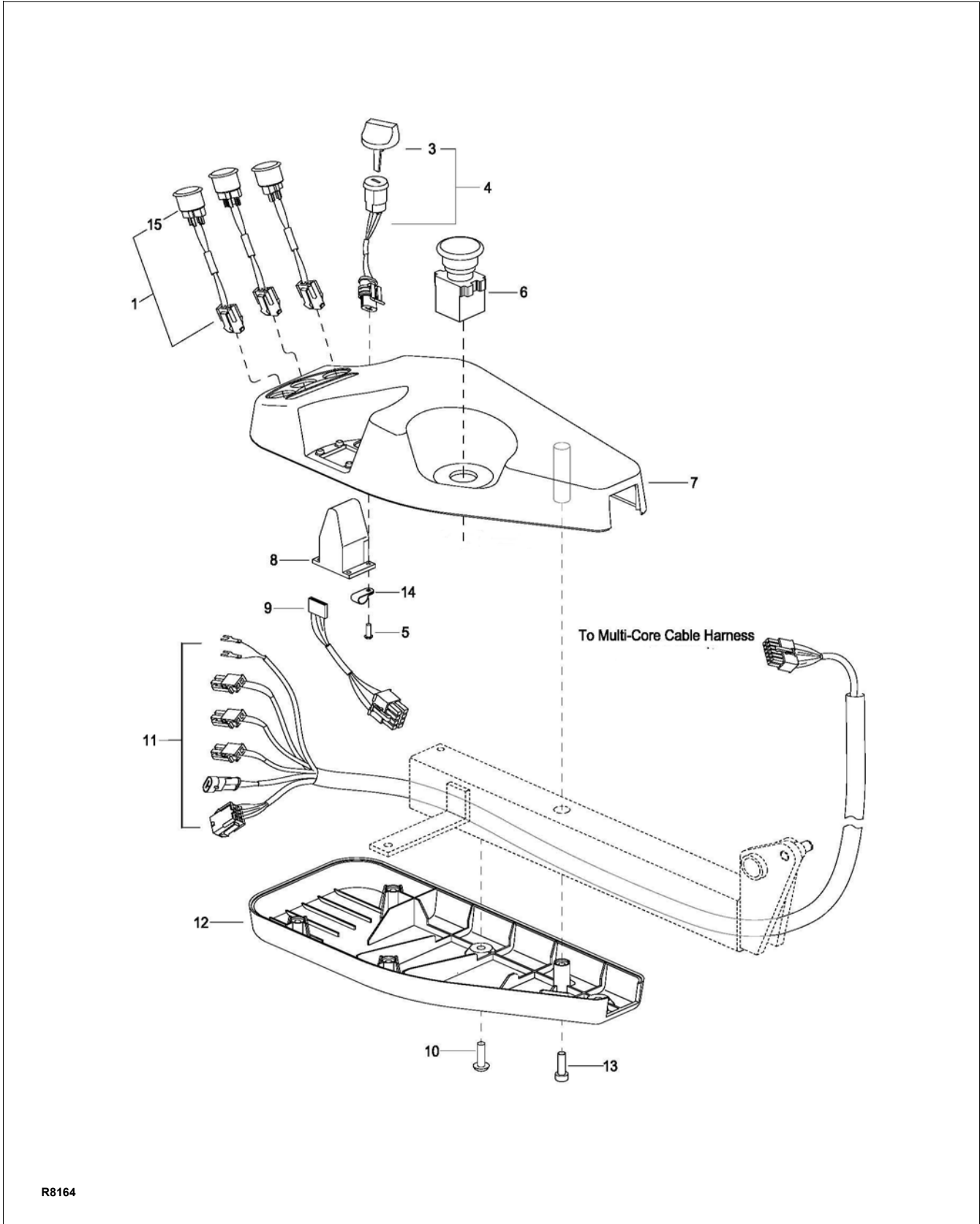

R8164

Figure 11-19 Control Arm (Right)

Control Arm (Right)

| POS. | PART NUMBER | DESCRIPTION | QTY. REQD. | NOTES |
|------|-------------------|------------------------------------|------------|--|
| -- | CK11-320000-00 | CONTROL ARM RIGHT ASSEMBLY | 1 | |
| 1 | CK11-520012-00 | BUTTON ASSEMBLY | 3 | |
| 3 | 1115-500016-00 | 2 WAY SWITCH KEY | 2 | |
| 4 | CK11-520009-00 | POWER SWITCH ASSEMBLY | 1 | |
| 5 | 0000-000998-00 | SCREW M3×8 | 4 | |
| 6 | 3218-604000-00 | EMERGENCY STOP SWITCH | 1 | |
| 7 | CK11-320001-00 | UPPER COVER OF RIGHT ARMREST | 1 | |
| 8 | CK11-560003-00 | JC100 SWITCH | 1 | Used up to Serial Number 227210207 |
| 8a | CK11-560003-00-10 | JC100 SWITCH - WITH WIRE HARNESS | 1 | Used from Serial Number 227210208 |
| 9 | CK11-520008-00 | FWD. / REV. SWITCH WIRE HARNESS | 1 | Used up to 05-08-2013 |
| 9a | CK11-520008-0A | FWD. / REV. SWITCH WIRE HARNESS | 1 | Used between 05-09-2013 and Serial # 227210207 |
| 10 | 0000-000001-00 | SCREW M6×20 | 2 | |
| 11 | CK10-520003-00 | WIRE HARNESS OF OPERATION PANEL(R) | 1 | |
| 12 | CK11-320002-00 | LOWER COVER OF RIGHT ARMREST | 1 | |
| 13 | 0000-000661-00 | SCREW M5×20 | 4 | |
| 14 | 0000-000490-00 | HARNESS CLAMP | 1 | |
| 15 | 1280-560004-00 | BUTTON | 3 | |

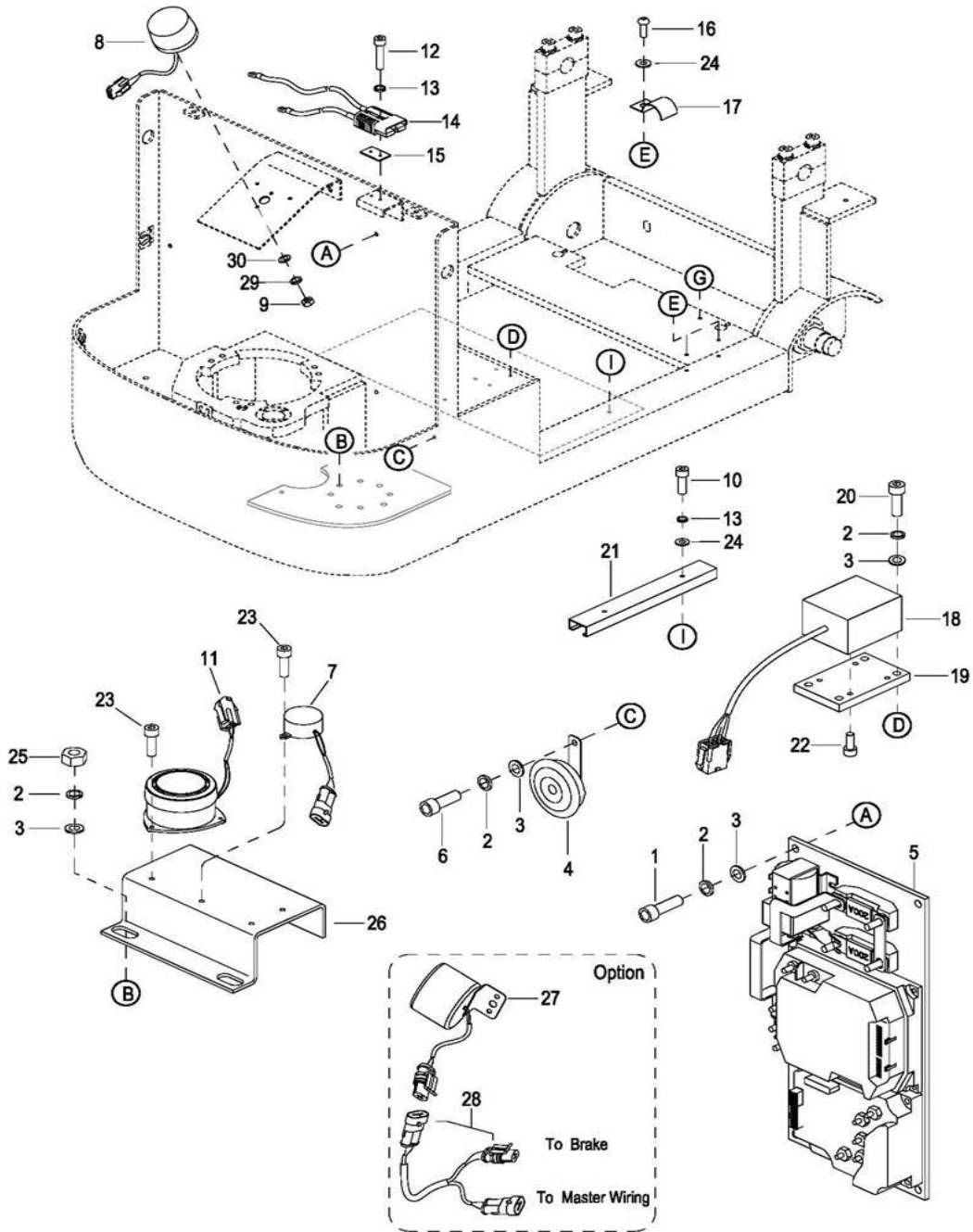

R8167

Figure 11-20 Electrical System

Electrical System

| POS. | PART NUMBER | DESCRIPTION | QTY. REQD. | NOTES |
|------|----------------|----------------------------|------------|--|
| 1 | 0000-000321-00 | SCREW M8×20 | 4 | |
| 2 | 0000-000159-00 | LOCK WASHER Ø8 | 9 | |
| 3 | 0000-000194-00 | FLAT WASHER Ø8 | 9 | |
| 4 | 1120-500003-00 | HORN | 1 | |
| 5 | -- | CONTROLLER BOARD ASSEMBLY | 1 | See Control Panel section |
| 6 | 0000-000118-00 | SCREW M8×10 | 1 | |
| 7 | CK11-520011-00 | BUZZER (LOWERING) | 1 | |
| 8 | CK10-520015-00 | WARNING LAMP | 1 | Used up to Serial # 225170105. Order CK10-520015-10 Flashing Light and add 2 x 0000-000139-00 Nut, 2 x 0000-000122-00 Lock Washer, 2 x 0000-000702-00 Flat Washer. |
| 8a | CK10-520015-10 | WARNING LAMP | 1 | Used from Serial Number 225170106 |
| 9 | 0000-000998-00 | SCREW M3×8 | 2 | |
| 9a | 0000-000139-00 | NUT M4 | 2 | |
| 10 | 0000-000384-00 | SCREW M6×40 | 2 | |
| 11 | CK10-520011-00 | BUZZER (LEVEL SENSOR) | 1 | |
| 12 | 0000-000430-00 | SCREW M6×50 | 2 | |
| 13 | 0000-000056-00 | LOCK WASHER Ø6 | 4 | |
| 14 | CK10-531100-00 | CONNECTOR BATTERY ASSEMBLY | 1 | |
| 15 | 1120-112008-00 | PLATE | A.R. | As Required |
| 16 | 0000-000179-00 | SCREW M6×10 | 2 | |
| 17 | CK10-510033-00 | HARNESS CLAMP | 2 | |
| 18 | CK10-520009-00 | LEVEL SENSOR | 1 | |
| 19 | CK10-510016-00 | LEVEL SENSOR PLATE | 1 | |
| 20 | 0000-000321-00 | SCREW M8×20 | 4 | |
| 21 | CK10-510032-00 | WIRE GROOVE | 1 | Used up to Serial Number 226210149 |
| 21a | CK10-510032-0A | WIRE GROOVE | 1 | Used from Serial Number 226210150 |
| 22 | 0000-000009-00 | SCREW M4×12 | 4 | |
| 23 | 0000-000009-00 | SCREW M4×12 | 2 | |
| 24 | 0000-000123-00 | FLAT WASHER Ø6 | 4 | |
| 25 | 0000-000550-00 | NUT M8 | 1 | |
| 26 | CK10-510030-40 | BUZZER PLATE | 1 | |
| 27 | 3712-405000-00 | ALARM BUZZER | 1 | Option |
| 28 | CK10-520020-00 | ALARM BUZZER WIRING | 1 | Option |
| 29 | 0000-000122-00 | LOCK WASHER Ø4 | 2 | Used from Serial Number 225170106 |
| 30 | 0000-000702-00 | FLAT WASHER Ø4 | 2 | Used from Serial Number 225170106 |

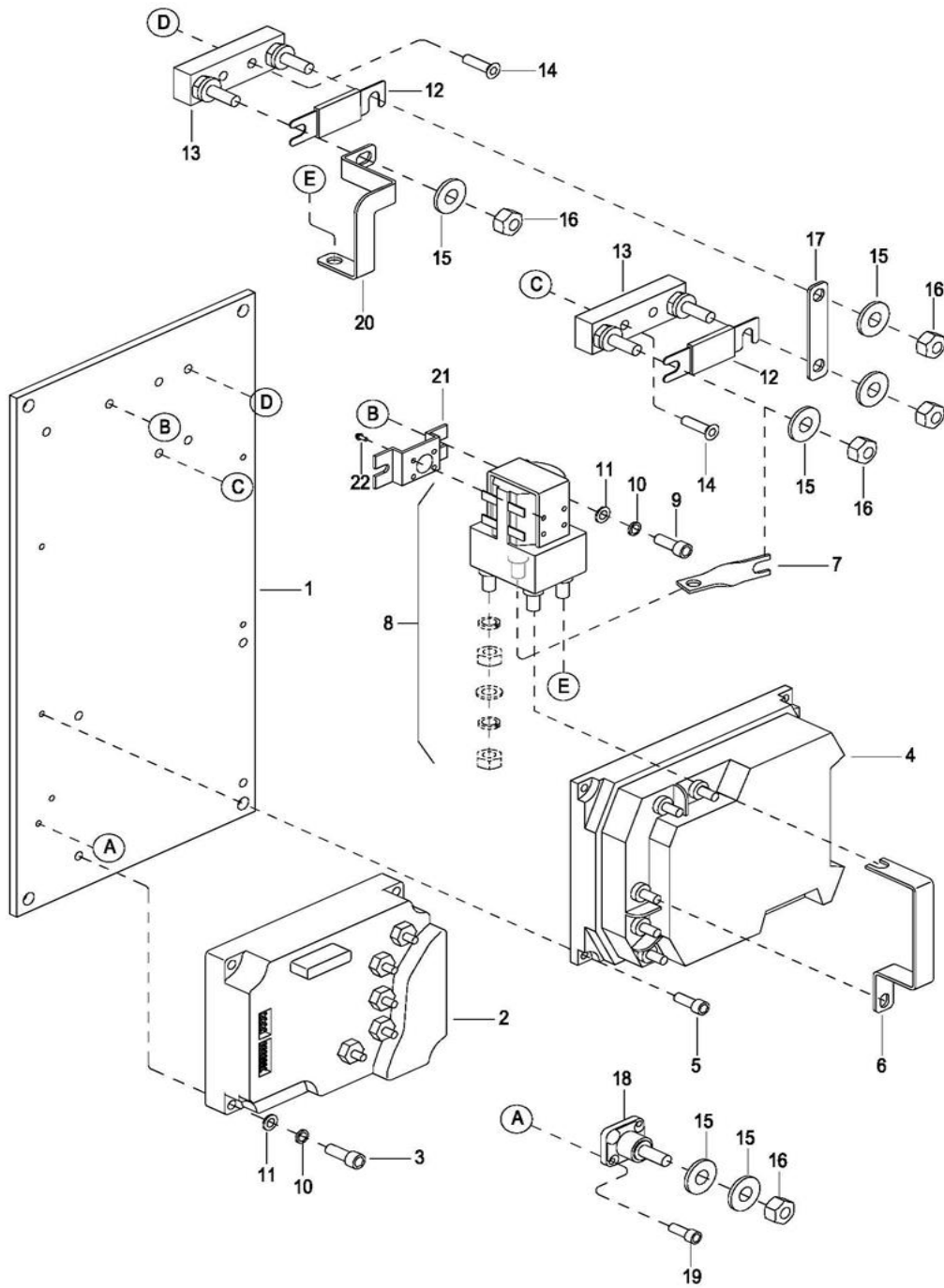

R8168

Figure 11-21 Control Panel

Control Panel

| POS. | PART NUMBER | DESCRIPTION | QTY. REQD. | NOTES |
|------|-------------------|------------------------|------------|--|
| 1 | CK10-510001-00 | BOARD | 1 | |
| 2 | 1280-560002-00-00 | EPS CONTROLLER | 1 | |
| 3 | 0000-000032-00 | SCREW M6×25 | 4 | |
| 4 | SERIAL # REQUIRED | CONTROLLER ACO-SSL150A | 1 | Please contact Big Lift with a Serial # of the truck so that the correct part # can be quoted. |
| 5 | 0000-000004-00 | SCREW M5×12 | 4 | |
| 6 | CK11-510002-00 | AC0 COPPER CONDUCTOR | 1 | |
| 7 | 1120-530006-00 | COPPER CONDUCTOR | 1 | |
| 8 | CK10-560001-00 | CONTACTOR | 1 | |
| 9 | 0000-000077-00 | SCREW M6×12 | 2 | |
| 10 | 0000-000056-00 | LOCK WASHER Ø6 | 6 | |
| 11 | 0000-000380-00 | FLAT WASHER Ø6 | 6 | |
| 12 | 1120-540002-00 | FUSE 200A | 2 | |
| 13 | 1120-540001-00-B | STAND | 2 | |
| 14 | 0000-000074-00 | SCREW M6×20 | 4 | |
| 15 | 0000-000210-00 | FLAT WASHER Ø8 | 6 | |
| 16 | 0000-000196-00 | NUT M8 | 5 | |
| 17 | 2322-510003-00 | COPPER CONDUCTOR | 1 | |
| 18 | 1220-500005-00 | TERMINAL | 1 | |
| 19 | 0000-000088-00 | SCREW M4×8 | 2 | |
| 20 | CK10-510002-00 | COPPER CONDUCTOR | 1 | |
| 21 | CK10-560002-00 | CONTACTOR BRACKET | 1 | Used from Serial # 2281000299 |
| 22 | 3020-270000-01 | SCREW | 2 | Used from Serial # 2281000299 |

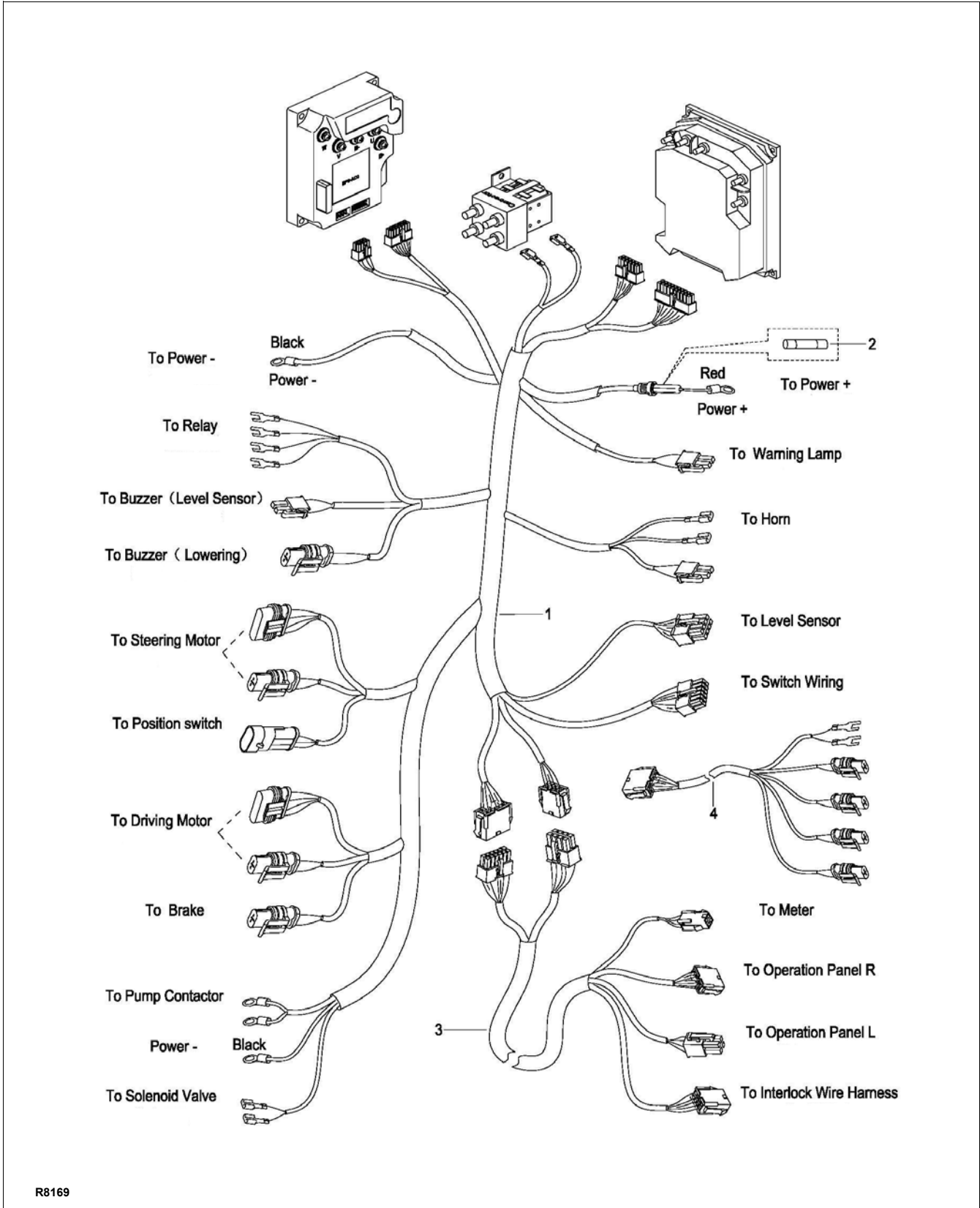

R8169

Figure 11-22 Wiring Harness

Wiring Harness

| POS. | PART NUMBER | DESCRIPTION | QTY. REQD. | NOTES |
|-------------|--------------------|--------------------------|-----------------------|--------------|
| 1 | CK10-520001-0A | MASTER WIRING HARNESS | 1 | |
| 2 | 1120-500010-00 | FUSE 10A | 1 | |
| 3 | CK10-520010-00-05 | MULTI-CORE CABLE HARNESS | 1 | |
| 4 | CK10-520017-00 | COMMUNICATION WIRING | 1 | |

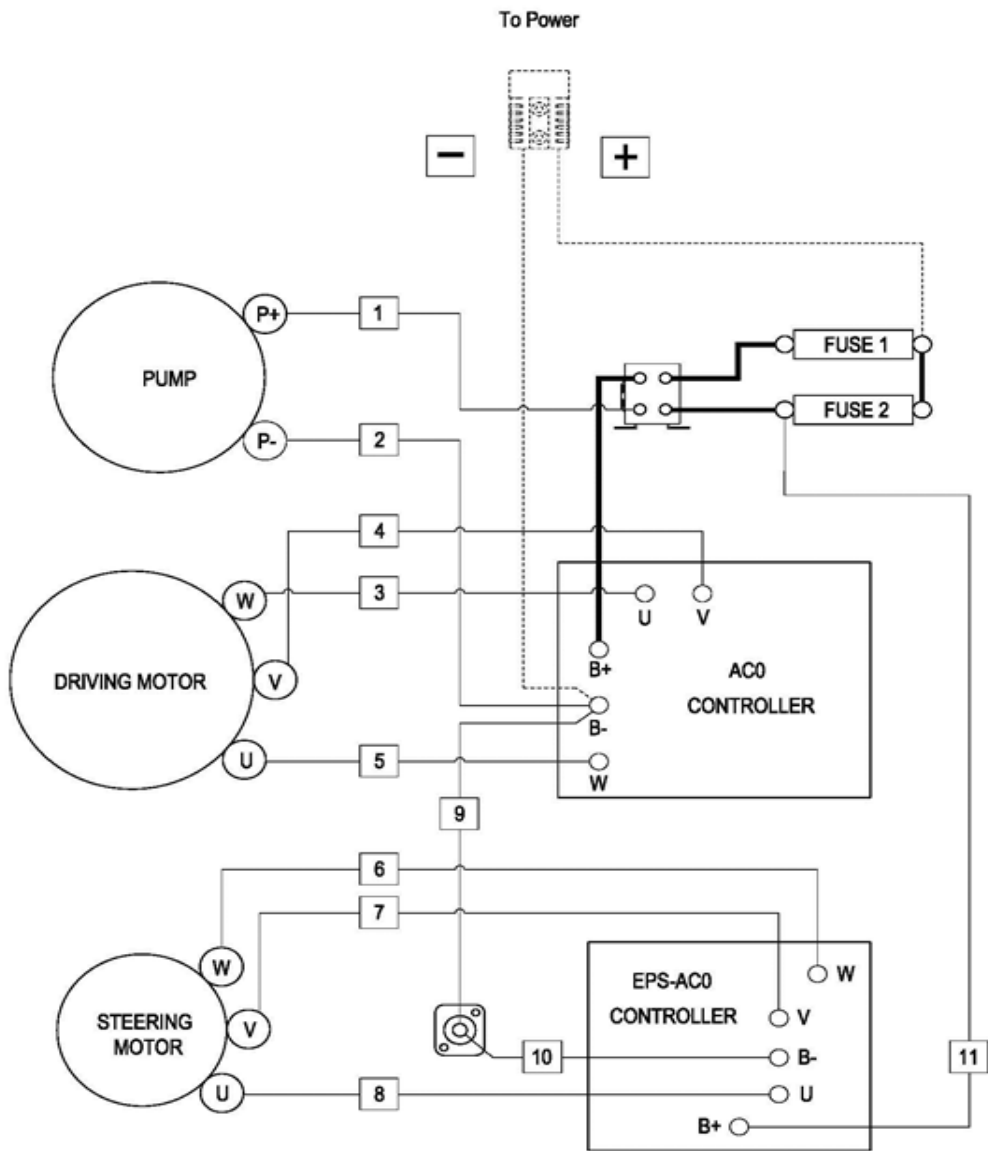

R8170

Figure 11-23 Wiring Cables

Wiring Cables

| POS. | PART NUMBER | DESCRIPTION | QTY. REQD. | NOTES |
|------|----------------|------------------------|------------|-------|
| 1 | CK10-531009-00 | PUMP POWER CABLE PA | 1 | |
| 2 | CK10-531010-00 | PUMP POWER CABLE PA | 1 | |
| 3 | CK10-531001-00 | DRIVE MOTOR CABLE U | 1 | |
| 4 | CK10-531002-00 | DRIVE MOTOR CABLE V | 1 | |
| 5 | CK10-531003-00 | DRIVE MOTOR CABLE W | 1 | |
| 6 | CK10-531006-10 | STEERING MOTOR CABLE W | 1 | |
| 7 | CK10-531005-10 | STEERING MOTOR CABLE V | 1 | |
| 8 | CK10-531004-10 | STEERING MOTOR CABLE U | 1 | |
| 9 | CK10-531013-00 | (D-AC0) CABLE | 1 | |
| 10 | CK10-531007-00 | (D-EPS-AC0) CABLE | 1 | |
| 11 | CK10-531008-00 | (EPS-AC0) CABLE | 1 | |



Big Lift LLC