

Timber/Stanchion Trailers



Pan-European competency.

For 150 years, Schwarz Müller has been making commercial vehicles for specific demands. Our customers benefit from this experience by the value added to their purchases.

Schwarz Müller Group is a family-owned enterprise based in Austria yet active internationally. Considered one of today's leading European commercial vehicle suppliers the Group centres its currently 21 sites in Central and Eastern Europe.

Schwarz Müller provides not only a broad range of vehicles but also optimised solutions for almost any industry. More than once, the premium manufacturer and innovation leader has set the pace regarding payload and handling and is thus decidedly adding value to everyday applications.

Another factor that has been speaking in Schwarz Müller's favour for decades is the Group's extensive service offering covering the entire product lifecycle: Significantly extends for vehicle's useful life. Services include everything from maintenance and OEM spare parts availability to rentals and leasing.

Schwarz Müller Group produces at four sites: Special-purpose vehicles are made at its Upper Austrian headquarters. Standard and near-stand-

ard vehicles are made in the Czech Republic and Hungary, whereas skip container vehicles are made in Neustadt/Dosse. Our annual production output amounts to about 11,000 vehicles. Over 350 service centres located along the major European transport routes ensure that your vehicles will remain available for everyday use.

Since 1871, Schwarz Müller has been working to win and retain industrial innovation and technology leadership based on the competency and know-how of its employees. Lightweight design and its benchmarks set by Schwarz Müller for over 25 years is but one example.

Other areas include construction, metal structures or welding where Schwarz Müller periodically kicks off new developments or often is the first supplier using new vehicle manufacturing technologies. This is how turn innovation into mass production. Thus, if you are looking for smart vehicle solutions, special requirements or top quality, try Schwarz Müller to find an ideal partner.



Smart visionary vehicles.

A Schwarz Müller vehicle must successfully face various challenges. This is why construction makes the first difference.

Compared to towing vehicles, the role of commercial trailers will further gain in importance because, owing to current traffic densities as well as infrastructural and legal constraints, the number of towing vehicles will grow but slowly. The performance of both trailers and bodies therefore needs to increase. Schwarz Müller is driving this development with smart designs: Bodies and trailers provide many improvement options from payloads, longer useful lives and simplified handling to cost reductions.

A competent and innovative team of over 2,150 development, design and manufacturing personnel share Schwarz Müller's vision and turn it into smart vehicle. Latest innovations such as the POWER LINE semitrailer, the first walking floor weighing less than seven tons or the thermo-tipper trailer for transporting temperature-controlled asphalt are impressive examples of this spirit of innovation.

And quality is not an accidental feature of Schwarz Müller either: 3D design down to the

smallest detail and highly efficient quality assurance methods ensure that the vehicles are powerful performers in everyday practice.

A typical characteristic of Schwarz Müller is the specialised handling of steel and aluminium in production. It is one of fundamentals of the premium quality that Schwarz Müller vehicles are distinguished by.

The vehicles of the two Schwarz Müller and Hüf-fermann brands roll out to the construction sec-

tor, infrastructure companies, raw materials and reusables industries and short-distance & long haul forwarders. The enterprise is the only full-range supplier at premium level to make eight groups including a total of 150 different types of vehicles. Our more than 1,000 model variants satisfy almost any specific wish a customer may have. All of these vehicles share top-level quality, sturdiness, toughness and an optimised payload.

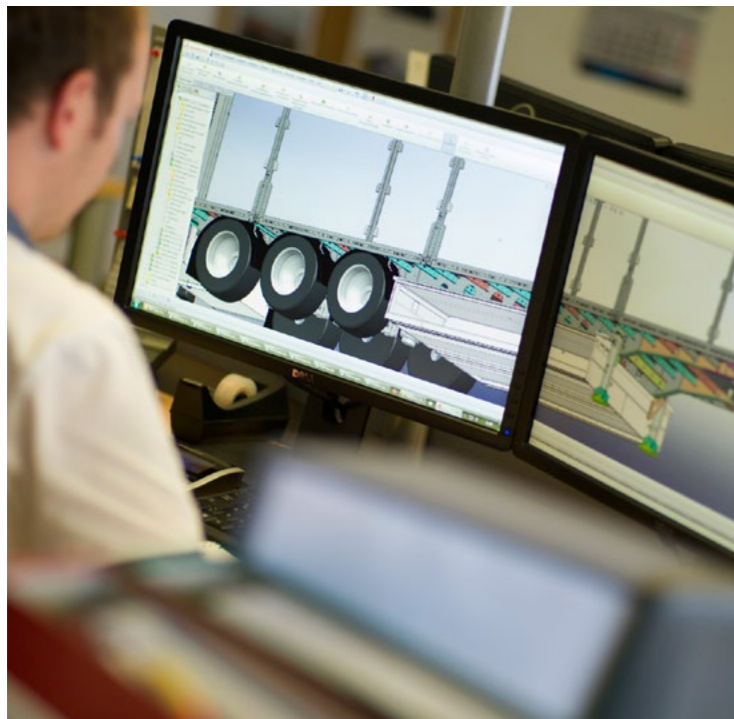

Intelligent Solutions for All Requirements.

Timber/stanchion trailers from Schwarz Müller combine lightweight construction with extreme robustness. They are tailored perfectly to the demands of the timber industry and show their quality on any terrain.

Requirements for use in forests vary greatly from region to region. The narrow mountain roads of the Alpine region pose challenges for transportation vehicles which are quite different from those of the heavily wooded areas of Eastern Europe. With its various vehicle models, Schwarz Müller offers the required flexibility to be optimally prepared for any scenario.

The drawbar trailers with twin tyres for optimum stability are ideal for steep and narrow forest roads or poorly developed roads. A version platform loading surface is available for the secure transportation of timber.

Austria's premium manufacturer proves its innovative edge with its latest, highly-robust semi-trailer. Thanks to the typical Schwarz Müller lightweight construction and a net weight from 4.9 tonnes, this model enables a significantly greater payload. The risk of overloading when off-road is reduced considerably too.

A short central-axle stanchion trailer, particularly impressive when it comes to manoeuvring, rounds up the product portfolio.



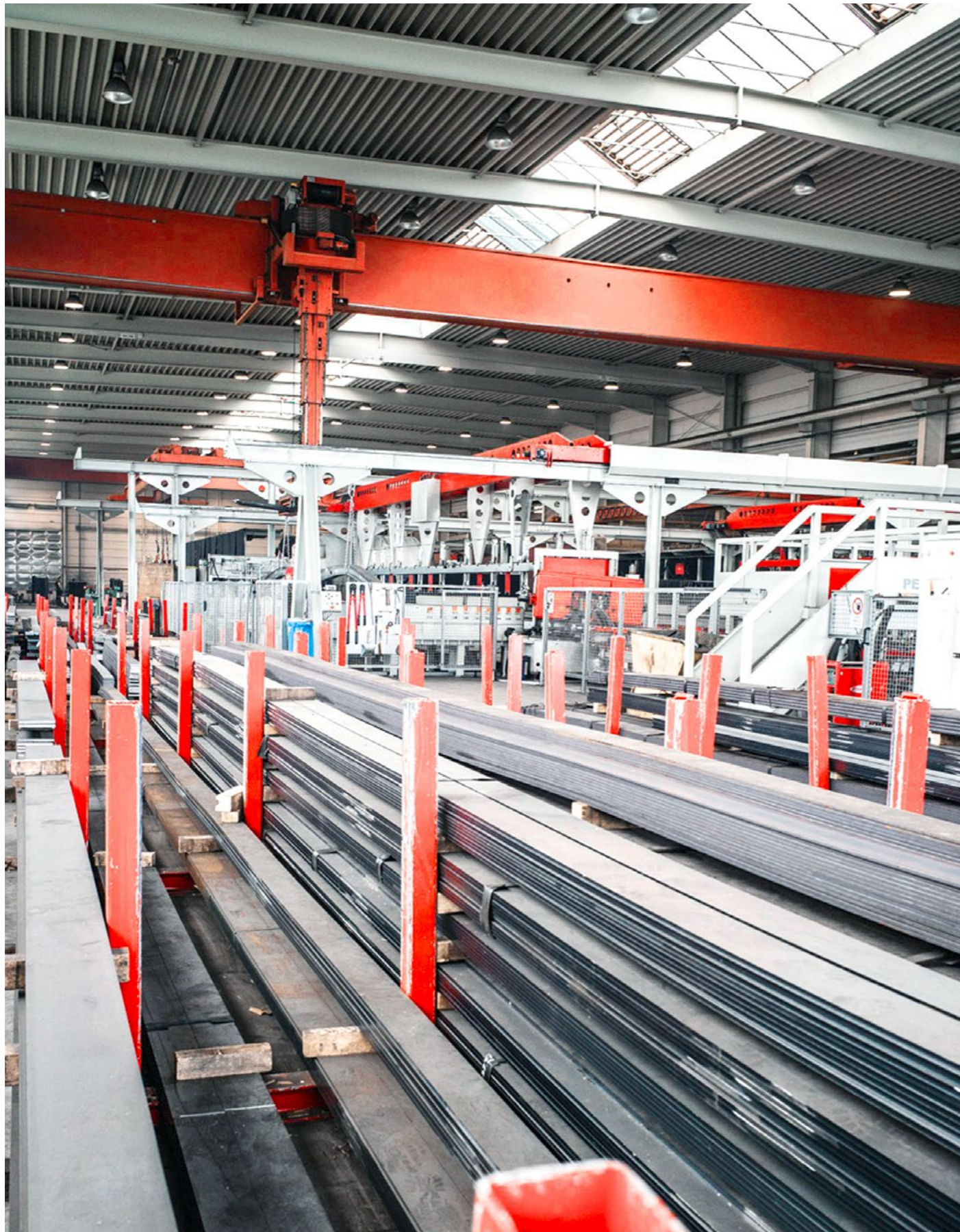

Outstanding Quality for the Timber Industry.

All timber/stanchion trailers from Schwarzmüller are characterised by their ultra low weight but extreme robustness and superior stability. The innovative lightweight Schwarzmüller design and the

use of robust Naxtra steel produce torsionally flexible vehicles of outstanding quality. Only high quality raw materials and components such as ExTe stanchion posts and axles from renowned manufacturers are installed.

Semi-trailer



Drawbar trailer



Central-axle trailer



	Stanchion semi-trailer		Central-axle stanchion trailer	Drawbar stanchion trailer	
	2-axle	3-axle	2-axle	2-axle	3-axle
Technical axle loads	2 x 9 t / 2 x 10 t	3 x 9 t	2 x 9 t / 2 x 10 t	2 x 9 t / 2 x 10 t	3 x 9 t
Imposed load	18 t	12 t			
Technical total weight	36 t / 38 t	39 t	19 / 21 t	18 t / 20 t	27 t
Net weight	from 4.1 t	from 4.9 t	from 2.5 t	from 2.9 t	from 3.7 t
Tyres	single / twin	single	single / twin	single / twin	single / twin
Stanchion posts	6 / 8 / 10	6 / 8 / 10	2 / 4	2 / 4	2 / 4 / 6

Standard Equipment.

Schwarz Müller timber/stanchion trailers set benchmarks in terms of payload, handling and service life - even in the standard version. Even in the standard configuration, these offer countless solutions which guarantee a superior performance from these vehicles on a daily basis. The symbols indicate which configuration detail corresponds to which feature.

LEGEND

- ⊖ Efficiency
- ⊙ Stability
- ⚠ Driver safety
- ⊙ Load safety
- ⊕ Added value



1 **Mounted fitted timber-stad**
These are attached to the vehicle by clamp fastening and therefore horizontally-adjustable as required. They serve to ensure secure transportation of the cargo (logs).



2 **Clamshell protection plates**
Clamshell protection plates on the side members prevent the clamshell from causing damage during unloading.



3 **Aluminium underride guard**
This ensures that the trailer or semi-trailer cannot be underridden, improving safety for other road users. Also available in steel or stainless steel.

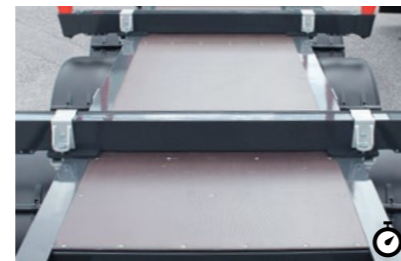



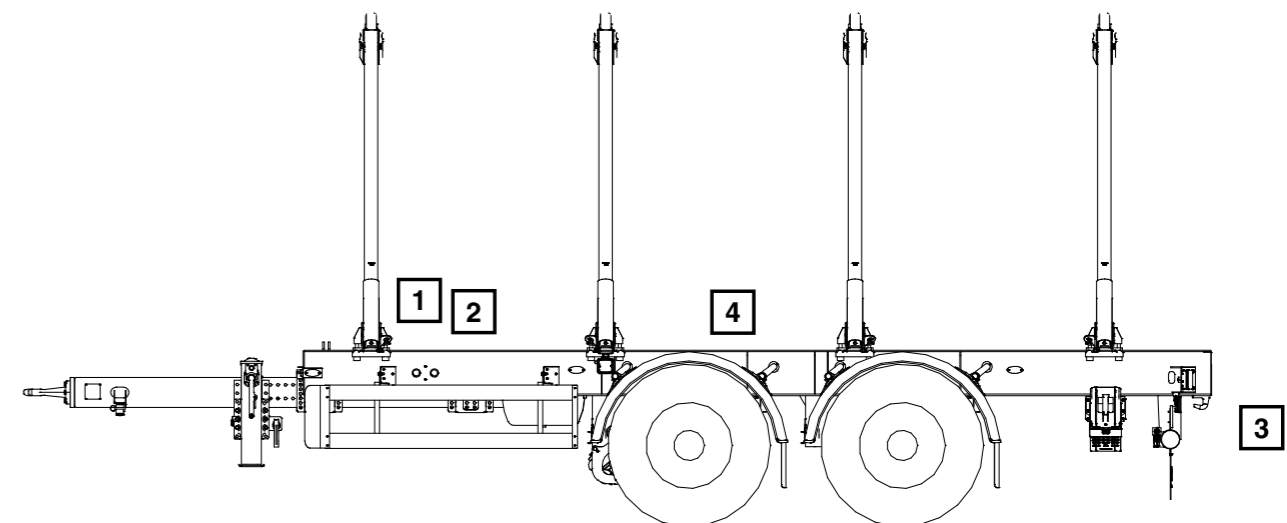
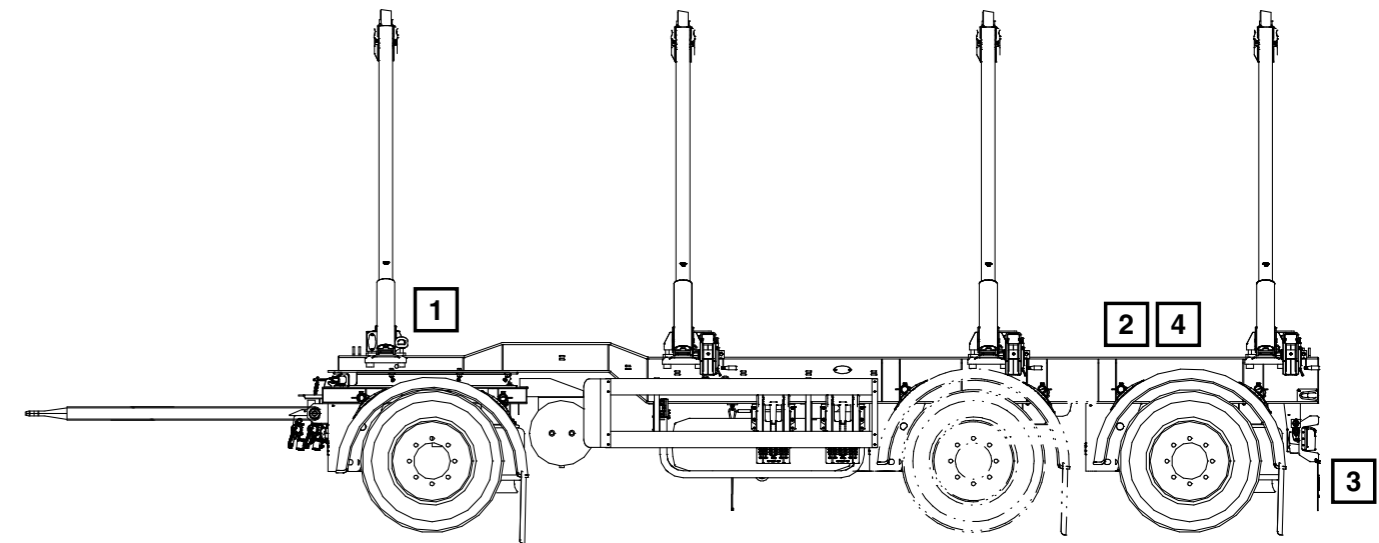
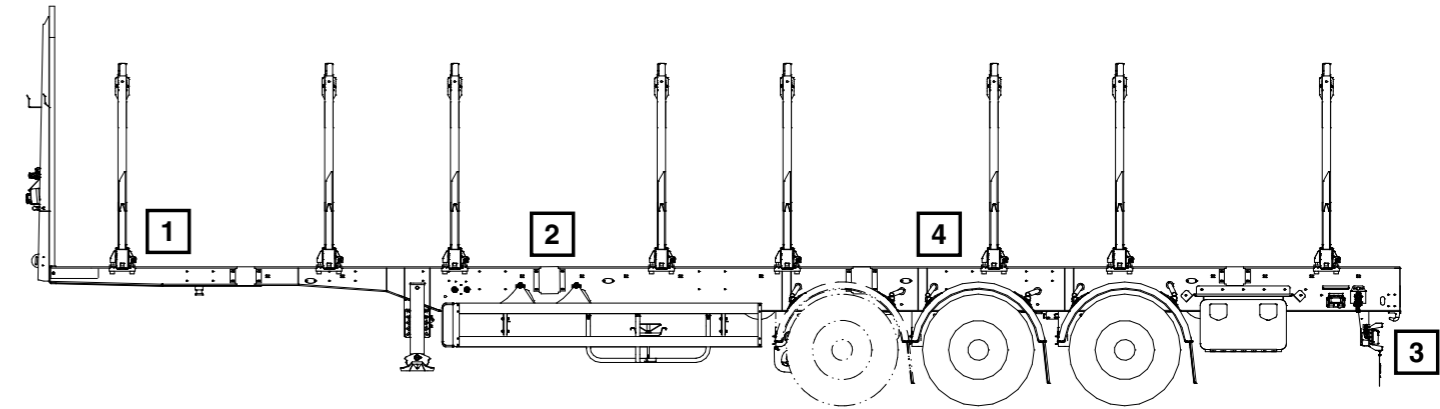





4 **plywood trailer flooring**
The cover between the side members protects the components underneath, such as valves. Optionally as a grooved plate cover in aluminium or steel.

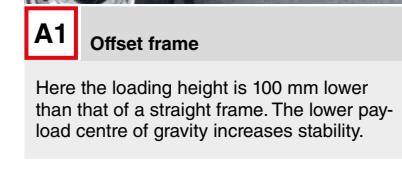

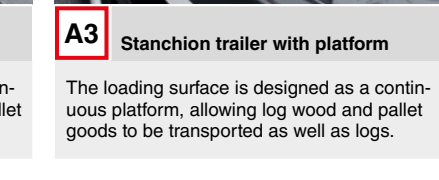
Optional Equipment.

Schwarz Müller timber/stanchion trailers are constructed in line with individual customer specification. Optional configuration details improve the performance of the vehicle considerably. The symbols indicate which configuration detail corresponds to which feature.

 <p>A1 Offset frame</p> <p>Here the loading height is 100 mm lower than that of a straight frame. The lower payload centre of gravity increases stability.</p>	 <p>A2 Stanchion trailer with platform</p> <p>The loading surface is designed as a continuous platform, allowing sawn timber and pallet goods to be transported as well as logs.</p>	 <p>A3 Stanchion trailer with platform</p> <p>The loading surface is designed as a continuous platform, allowing log wood and pallet goods to be transported as well as logs.</p>
 <p>A4 Extendible frame</p> <p>The frame is extendible, therefore the length of the loading surface is adjustable. An optional feature in the drawbar trailer model.</p>	 <p>B Perforated outer frame (with the platform option)</p> <p>For securing loads during the transportation of log wood or pallet goods.</p>	 <p>C Tailgates (with the platform option)</p> <p>For securing loads during the transportation of sawn timber or pallet goods.</p>
 <p>D1 Contracted tow bar</p> <p>The contracted tow bar prevents drawbar damage.</p>	 <p>D2 Extendible tow bar</p> <p>An extendible tow bar protects the drawbar from any damage. It is length-adjustable.</p>	 <p>E Front wall (aluminium or steel)</p> <p>The front wall is an extra partition between the driver's cabin and the cargo which increases safety for the driver and cargo.</p>

 <p>F Stanchions</p> <p>Schwarz Müller only uses stanchion posts from reputable manufacturers. They serve to ensure secure transportation of the cargo (logs).</p>	 <p>G Welded stanchion sockets</p> <p>The welded timberjunks are permanently fixed to the vehicle.</p>	 <p>H Transverse support</p> <p>Like the clamshell protection plates, the transverse support prevents the clam from causing damage during unloading.</p>
 <p>I Double ball steering turntable</p> <p>The double ball steering turntable increases the permissible load on the turntable.</p>	 <p>J Central lubrication bar</p> <p>The lubrication points of the ball steering turntable can be reached from a central lubrication bar, thus simplifying the lubrication process and saving time.</p>	 <p>K Removable mudguards</p> <p>The mudguards may be removed in order to make it easier to fit the snow chains.</p>
 <p>L Rope or chains for trailer manoeuvring</p> <p>Ropes or chains on the trailer allow the manoeuvring of its position by crane.</p>	 <p>M Autonordic load winch</p> <p>This special reel device for the lashing strap serves as a means of load securing.</p>	 <p>N Lifting and lowering device</p> <p>The trailer or semi-trailer can be lifted or lowered via a special air valve.</p>
 <p>O Tool box</p> <p>There is the option of installing a tool box.</p>	 <p>P1 Snow chain bracket</p> <p>Ideal for carrying snow chains.</p>	 <p>P2 Spare wheel holder</p> <p>This is an easy way to transport a replacement wheel en-route.</p>

 <p>P3 Stanchion holder</p> <p>At the front wall there is the option of including an extra sockets for storing stanchions.</p>	 <p>P4 Shovel and broom holder</p> <p>Ideal for carrying equipment.</p>	 <p>Q Work lights</p> <p>Work lights provide extra lighting during the loading and unloading process.</p>
 <p>R Extendible long vehicle plate</p> <p>To ensure the safe transportation of long goods, the extendible long vehicle plate must be used where the cargo is overhanging the trailer.</p>	 <p>S Towing device</p> <p>Towing hooks ensure secure attachment of the trailer.</p>	 <p>T Dirt baffle plates</p> <p>Plates on the mudguards prevent the deposit of Wood waste.</p>
 <p>U Underride guard (steel or stainless steel)</p> <p>This ensures that the trailer or semi-trailer cannot be underridden, improving safety for other road users.</p>	 <p>V Weighing system (load weight)</p> <p>The weighing system monitors for any potential overloading.</p>	 <p>W Information system</p> <p>This control unit for trailers offers data and control functions such as tyre pressure monitoring, brake wear indicator, lifting axle control etc.</p>
 <p>X Grooved plate cover (aluminium or steel)</p> <p>The cover between the side members protects the components underneath, such as valves, from damage.</p>	 <p>Y Lifting axles</p> <p>Reduce tyre wear by means of automatic axle raising during empty runs.</p>	 <p>Z1 Steering axle</p> <p>For increased trailer manoeuvrability, also reduces tyre wear.</p>

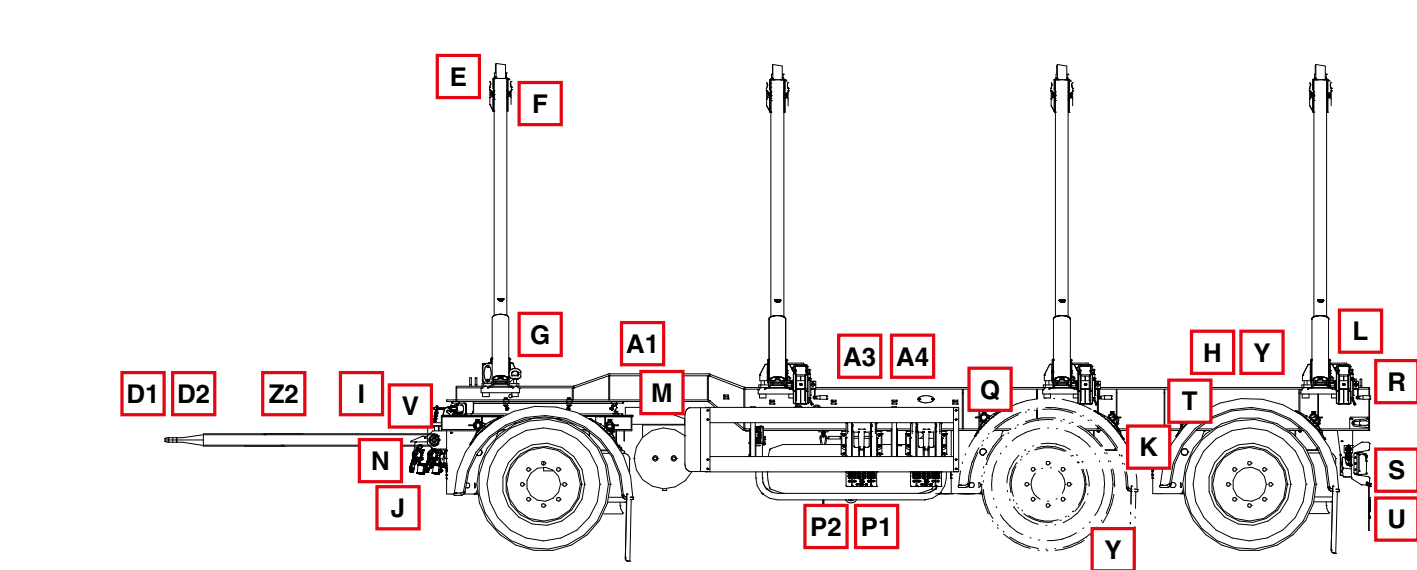
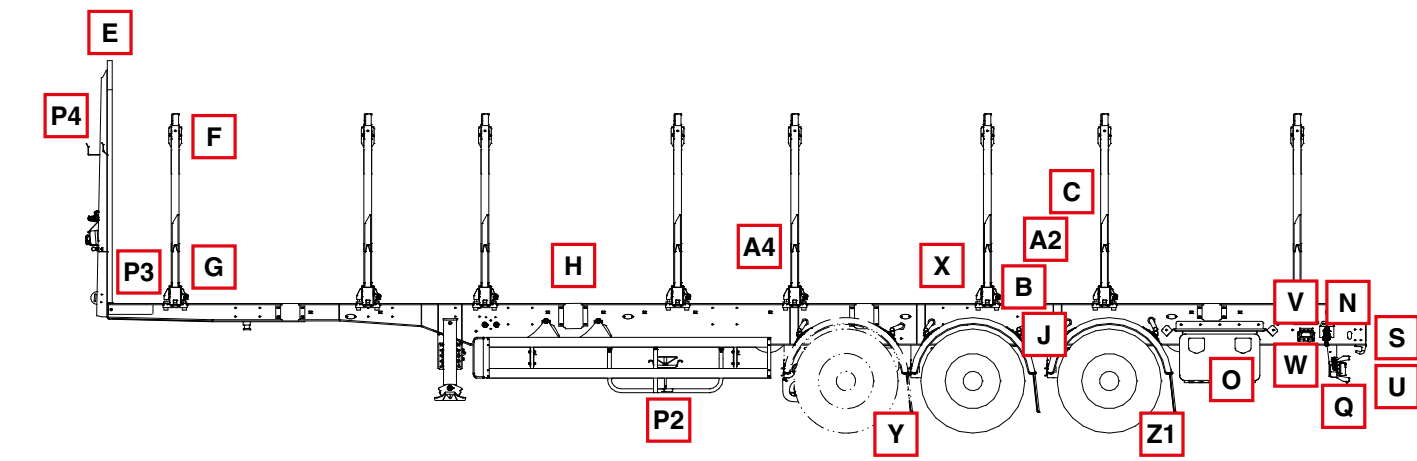

LEGEND

- ⊖ Efficiency
- ⊕ Stability
- ⚠ Driver safety
- ⊙ Load safety
- ⊕ Added value

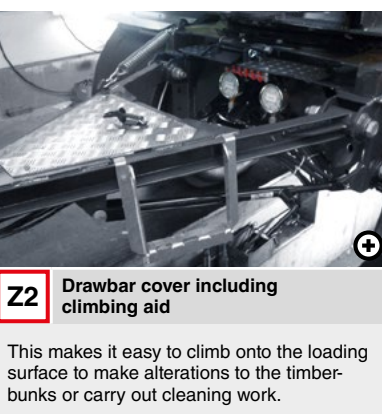

Z2 Drawbar cover including climbing aid

This makes it easy to climb onto the loading surface to make alterations to the timberjunks or carry out cleaning work.

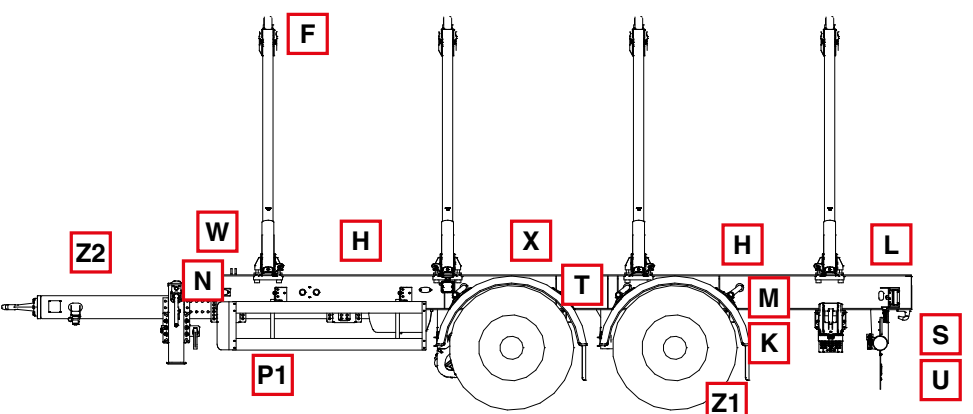

Best-in-class customer service.

Single source for solutions matching any Schwarz Müller vehicle requirement.

Schwarz Müller benefits its customers not only with an extensive product portfolio but also with a complete system services offering. Customers can rely on pinpoint solutions throughout their vehicles' entire lifecycle - in currently 21 countries.

Our own network of garages plus 350 further service partners ensure that your Schwarz Müller will always be and remain a Schwarz Müller. Our experts know exactly how to best maintain and service a Schwarz Müller vehicle. An international logistics

network allows permanently available OEM spares to be supplied rapidly.

Schwarz Müller runs one of Europe's largest fleet of hired standard and special-purpose vehicles. It helps you buffer peak demands without having to do without premium quality. Also ask for Schwarz Müller's tailored leasing opportunities. Schwarz Müller's own Financial Service or an external partner's service with or without a service agreement: It is always up to the customer to opt for the perfect answer to their needs.



Close to our customers in 21 countries.

Schwarz Müller Group and our sales partners currently run own sites (production, sales and service) in 21 Central and Eastern European countries. This international network and its about 2,150 employees are the basis of suc-

cessful relations with customers of many industries requiring challenging transport solutions. It allows Schwarz Müller to penetrate the entire market region with new vehicles and a portfolio of services throughout the entire lifecycle of its products.

- **MANUFACTURING SITES**
Dunaharaszti (Hungary),
Freinberg (Austria),
Neustadt/Dosse (Germany),
Žebrák (Czech Republic)
- **SALES COUNTRIES**
Austria, Belgium, Bosnia,
Bulgaria, Croatia, Czech Republic,
Germany, Hungary, Italy, Latvia,
Lithuania, Luxemburg, Netherlands,
Poland, Romania, Russia, Switzerland,
Serbia, Slovakia, Slovenia, Ukraine

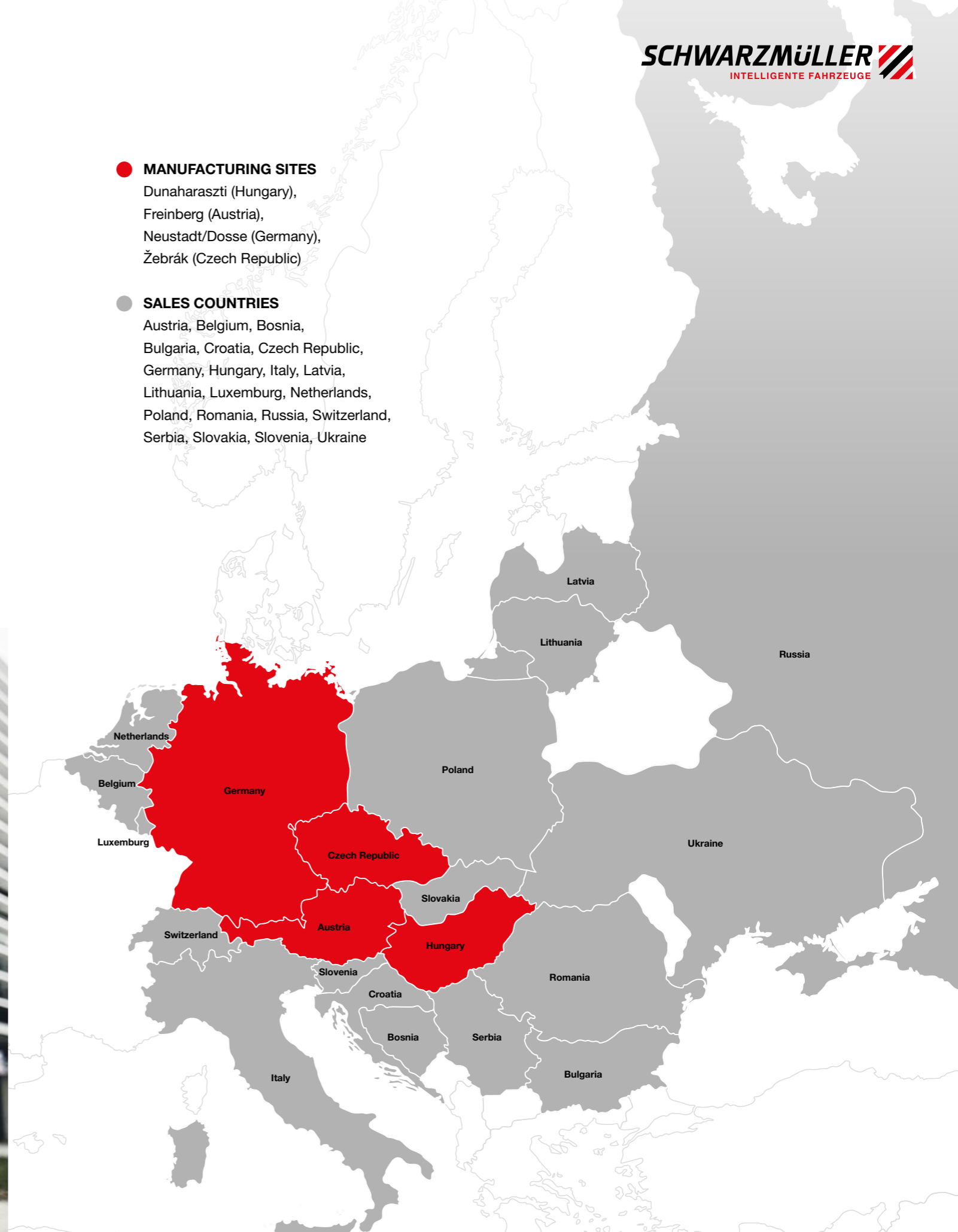

Intelligent full-range portfolio.

Schwarz Müller vehicles satisfy almost any transport need. From aluminium tank semi-trailer to centre-axle tipper trailers.

Schwarz Müller is proud of being able to supply its customers with smart vehicle for practically every application. Our eight product groups cover over 150 types of vehicles with more than one thousand model variants. All types of vehicles benefit from the know-how, core com-

petence and innovative power of the entire Group. They provide the perfect answer to the transport needs of the industries served. All Schwarz Müller vehicles stand for uncompromising premium quality to create real added value in everyday use.



Timber/stanchion vehicles

Timber



Tipper vehicles

Construction industry, agriculture, waste management



Body building vehicles

Construction industry, shipping/long haul transport, waste management



Platform vehicles

Shipping/long haul transport, construction industry



Walking-floor vehicles

Shipping/long haul transport, timber, waste management



Tank vehicles

Mineral oil



Low-loader vehicles

Construction industry



Container transport vehicles

Waste management



Schwarz Müller Group

Hanzing 11 · 4785 Freinberg · Austria

Phone: +43 7713 800-0

office@schwarzmueller.com

www.schwarzmueller.com/en

SCHWARZMÜLLER

Art.-Nr. 119950EN