

Lifetime Support Solutions.

Through our Lifetime Support Solutions, we ensure a seamless and hassle-free experience from the time you consider buying an Eicher vehicle to the time you think of selling. Our continuously improving and holistic services will ensure higher uptime and productivity for your BSVI vehicles.

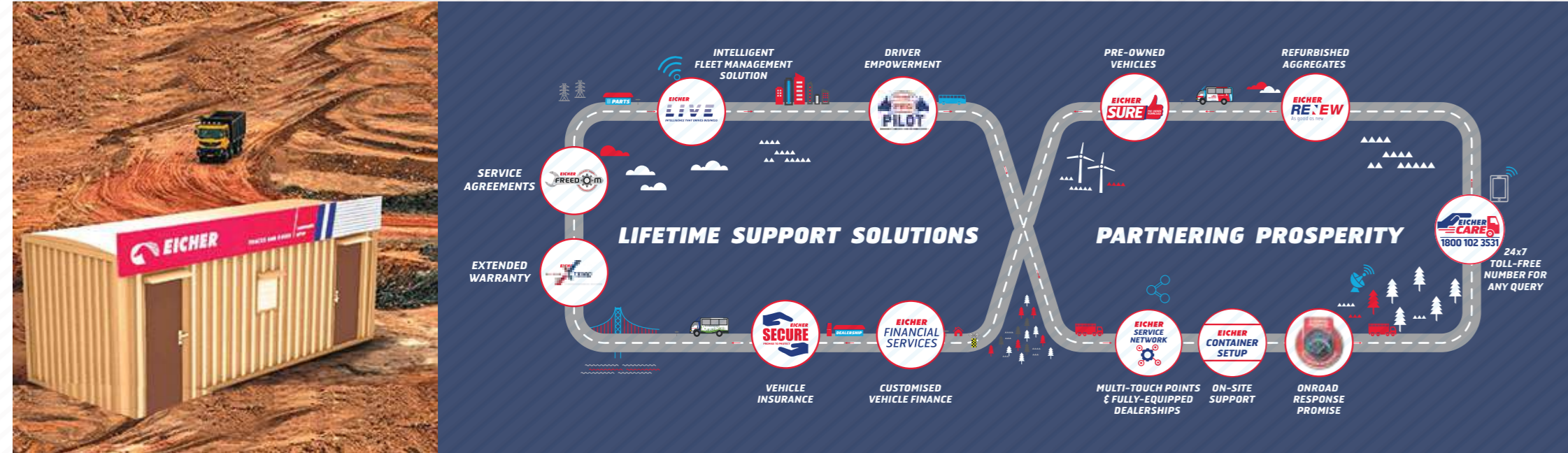

Eicher has taken a step towards achieving Superior Uptime, with a responsive attitude, that will set us apart and create a differentiated experience for our customers. With our new UPTIME CENTER and UPTIME CERTIFIED WORKSHOPS, we are now geared up with a proactive support system for diagnostic assistance through advanced diagnostic tools.



At Uptime Certified Workshops only
*T&C Apply

Model Eicher Pro 6028TM

GVW (kg)	28000					
Engine	VEDX5, BS-VI					
Max. Power	210 hp @ 2200					
Max. Torque	825 Nm @ 1200-1600 rpm					
Clutch (mm)	395 mm, Push Type, Single Dry Plate					
Gearbox	ET90S6					
Front Axle	Forged I-beam reverse elliot type axle with stabilizer bar					
Rear Axle	Heavy duty single reduction tandem axle					
Rear Axle Ratio	5.83					
Differential lock	Inter-axle					
Chassis Dimensions (mm)	300x76x7 with 5 mm full length inner liner					
Service brake	S-cam Dual line with ABS					
Parking brake	Pneumatically operated hand control valve					
Front Suspension	Parabolic					
Cabin	Day cabin					
Steering	Tilt and telescopic power steering					
Tyres	295/95D20, 11x20 (Nylon)					
Wheel Rims & Tyres	7.5x20					
Fuel Tank (Litres)	220					
DEF Tank (Litres)	33					
Battery	24 V: 120 Ah					
Turning Circle Diameter (m)	15.1 (4250 mm)/ 15.2 (4285 mm)					
Gradeability (%)	25 in 1 st Gear					
Ground Clearance (mm)	245/ 255					
Drum Size (Cum)	6	7	8			
Wheelbase (mm)	4250	4285	4250	4285	4250	4285
Rear Suspension	Slipper	Bogie	Slipper	Bogie	Slipper	Bogie
Drive	EPTO & Slave	EPTO & Slave	EPTO & Slave	EPTO & Slave	EPTO	EPTO & Slave
Standard Features	Eicher Live, Fuel Coaching, Cruise Control, M Booster+					

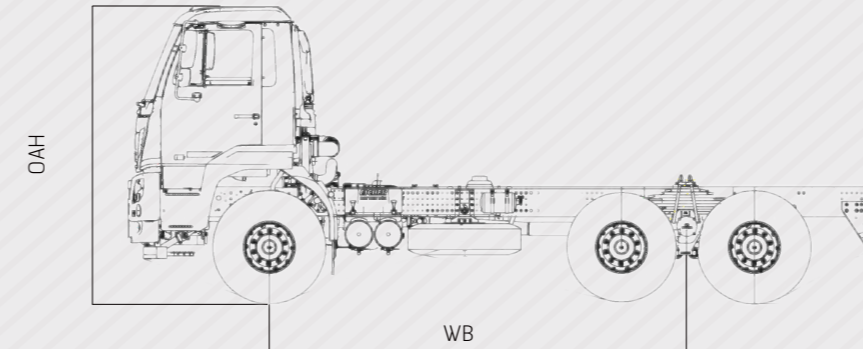
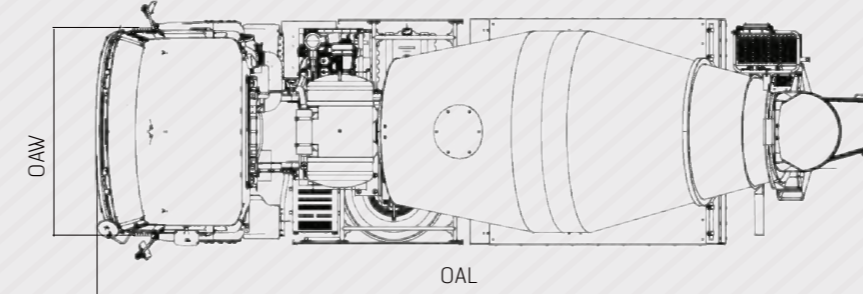

Vehicle Model	Wheelbase (mm)	Overall Length (OAL) mm	Overall Width (DAW) mm	Overall Height (DAH) mm
Pro 6028TM (CBC)	4250	7630	2496	2960
Pro 6028TM (CBC)	4285	7677	2496	2960
Pro 6028TM (8 C.u.M Drum) SLVE	4285	8870	2580	3800



VE COMMERCIAL VEHICLES
A VOLVO GROUP AND EICHER MOTORS JOINT VENTURE
eichertrucksandbuses.com, Eicher Care: 1800 102 3531

VE COMMERCIAL VEHICLES LTD.
Registered Address – 3rd Floor Select Citywalk,
A-3 District Centre, Saket, New Delhi 110017, India.
CIN – U74900DL2008PLC175032

CORPORATE ADDRESS
Eicher Trucks & Buses
#96, Sector – 32, Gurgaon
122001, Haryana, India.

Caution: *Do not weld or drill on chassis frame. *Accessories, colours and features shown in pictures or elsewhere may not constitute standard fitment. *Weight mentioned is for standard configuration with standard body sizes and will change due to optional fitments. *As a result of continuous research and innovation carried out, specifications are merely indicative and are subject to change without notice.

TRUCKS AND BUSES



DO MORE.

Eicher Pro 6028TM

The 28 Ton GVW Transit Mixer



EUTECH 6

EUTECH 6

Eicher is creating a new benchmark in the Indian commercial vehicle industry, through a revolutionary BSVI solution that combines global technology with innovative support services. This solution doesn't just make your vehicle BSVI compliant but ensures higher productivity of the truck and profitability for your business.



Euro VI Expertise for 6 Years

VECV has been manufacturing and supplying base engines to the Volvo Group since 2013. Over 1,00,000 Euro VI base engines supplied, operating in 41 countries. First to roll-out BSVI CV range in India, incorporating expertise of Euro VI technology.



Efficient EATS and Engine Technology

Best fluid economy: Lower fuel consumption + DEF consumption combined. Reliable EATS + engine technology tested for over 56,00,000 km. Vanadium based SCR for high reliability & low maintenance.



Enhanced UPTIME

Eicher Uptime Centre for 24x7 support by specialists. GPS enabled service vans just a phone call away. Remote diagnostics for quick repair of BSVI vehicles.



COMPACT BOX TYPE EATS FOR EFFICIENT THERMAL MANAGEMENT



The new Eicher Pro 6028TM, India's 1st 4 cylinder 6x4 transit mixer, is built on DO MORE philosophy to deliver best-in-class productivity and uptime through its versatile offering and benefit of higher payload, lower TCD, body friendly chassis, powerful engine PTO, low maintenance suspension and advance Telematics ensuring that construction projects stay on schedule.



More Tonnes Per Litre.

The all new Eicher Pro 6028TM is built to deliver best-in-class fuel efficiency thereby **reducing the operational costs**. The proven **VEDXS** engine clubbed with Volvo Group's EMS delivers **high peak torque over a wide range of RPM**, ensuring Pro 6028TM makes the most out of every drop of the fuel.

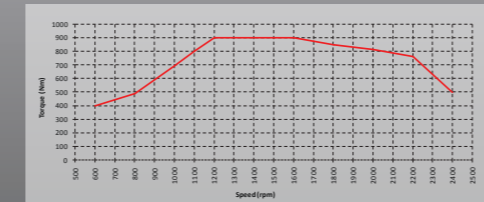

FIE System

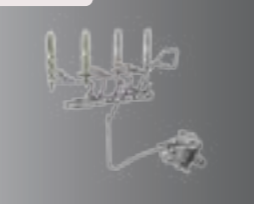

Volvo Group's EMS



ESS Compressor



- » Next-gen VEDXS common rail engine.
- » Optimum engine design with wider flat torque curve (1200 -1600 rpm).
- » Higher-power of 210HP @ lower 2200 rpm.
- » Aerodynamic cabin to reduce air drag.
- » First in Industry **Fuel Coaching** for improved driver performance.

More Trips. Faster Turnaround.

The Pro 6028TM is made with a robust and optimized driveline which delivers **high torque at wheels-5.83 FDR** to carry higher loads in the toughest of terrain. Higher power to **weight ratio provide higher** pulling power and superior gradeability leading to **faster turnaround and more trips**.

- » High peak torque of 825 Nm.
- » High gradeability -25% (1st Gear) and low TCD - 15.1 m
- » High torque at wheels with 5.83 FDR.
- » Heavy duty slipper & bogie suspension.
- » Ergonomically designed cabin for driver productivity.

Slipper Suspension



Bogie Suspension



Maximum Gradeability 25%



Superior Uptime.

To ensure that construction projects stay on schedule, concrete must reach its destination quickly and be processed in good time. Hence **Uptime is key** and Pro 6028TM is designed to **deliver superior Uptime to ensure that operations never stop**. So you can maximize your asset.



On-board Diagnostics



ET90 6-speed Gearbox

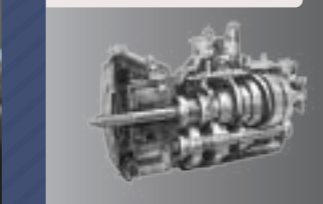

Bigger Crown Wheel



- » Reliable VEDXS engine with longer L10 Life.
- » Reliable and robust aggregates for higher uptime.
- » High strength DOMEX Chassis.
- » Slipper suspension for superior uptime.
- » Engine Protection System.
- » On-Board Diagnostics & **EICHER LIVE**.
- » Synchronized Service Intervals for lesser visits to workshops.

More Comfort. Enhanced Safety.

Pro 6028TM Cabin has been designed keeping in mind long driving hours and difficult conditions. The **global cabin** provides a **comfortable workspace** that ensures they are not only comfortable, but alert for longer hours.

- » All round mirrors for better visibility.
- » Improved front parabolic suspension.
- » Tilt and telescopic power steering.
- » 6-way adjustable driver seat.
- » Intelligent Driver Information System (IDIS) & Cruise Control.
- » Easy to shift gearbox

