

INTRODUCTION

This manual has been prepared with the assistance of service and engineering specialists to provide you, Daewoo heavy commercial vehicle mechanics, with the information on the electrical equipment of Daewoo heavy duty trucks. We like to assure you that you will be acquainted with more suitable maintenance techniques. It contains a variety of illustrations and diagrams for the electrical equipment to help you easily understand.

Utilizing adequately this manual for you maintenance operations will not only greatly relieve you from unnecessary effort but also enhance maintenance reliability.

Should you have any questions or doubt as to the contents of this manual, do not hesitate to contact us.

Finally, we like to advise you that the specifications and other details on our Daewoo heavy commercial vehicles and are subject to change without prior notice for the purpose of product upgrading, and also we hope that this manual would be of a great help to you in your maintenance operations.

2003. 12

DAEWOO COMMERCIAL VEHICLE CO, LTD

CONTENTS

- DE / DV -

SECTION 1.

GENERAL DESCRIPTIONS	5
----------------------------	---

SECTION 2.

CIRCUIT DIAGRAM BY SYSTEMS	24
----------------------------------	----

SECTION 1

GENERAL DESCRIPTIONS

1. ELECTRIC CIRCUIT DIAGRAM	6
1-1. HOW TO USE CIRCUIT DIAGRAM	
1-2. POWER SUPPLY NUMBER	
1-3. COLOR SYMBOLS FOR WIRING	
1-4. HOW TO KNOW CONNECTOR PIN NUMBER	
2. LOCATIONS OF ELECTRICAL HARNESES	8
2-1. ROOF / DASH / DOOR HARNESS	
2-2. FRAME HARNESS (DE/DV)	
2-3. CONNECTOR CONDITION	
2-4. LOCATIONS OF GROUND CONNECTIONS	
2-5. FUSE AND RELAY LAYOUT	
2-6. AUXILIARY FUSE AND RELAY BOX	

1. ELECTRIC CIRCUIT DIAGRAM

1-1. HOW TO USE CIRCUIT DIAGRAM

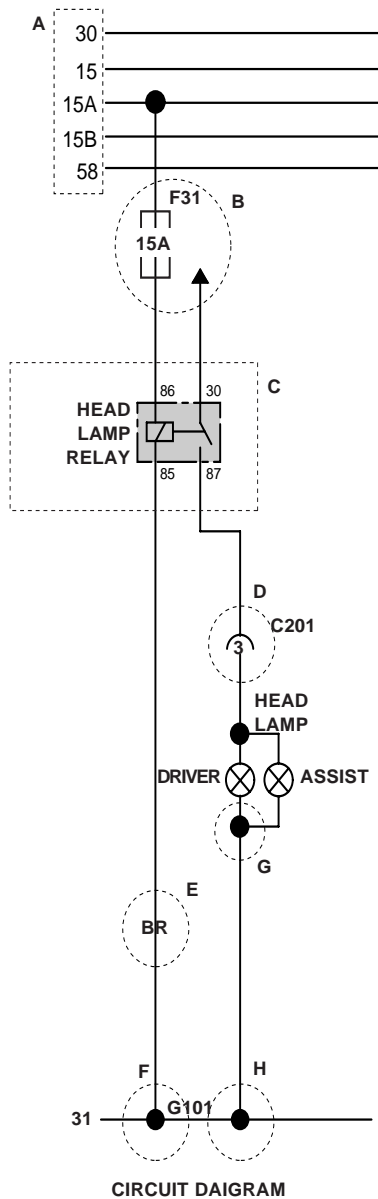

LOCATION	CONTENTS
A	<ul style="list-style-type: none"> The power supply line on the circuitry are found in the upper space of the circuit diagram. Power supply lines are #30, 15, 15a,15b, 58
B	<ul style="list-style-type: none"> F31 : Fuse number, 15A : Electric capacity.
C	<ul style="list-style-type: none"> This section shows the parts name and the pin number.
D	<ul style="list-style-type: none"> This section represents the connector where different wirings are connected to each other. C201 indicates the kind of connector, while the #3 means that it is the third terminal of the connector.
E	<ul style="list-style-type: none"> This section shows the color of the applicable wire. - BR - : Red stripes on black ground.
F	<ul style="list-style-type: none"> This section indicates the location of ground Connection. The bottom line is a battery(-) line or ground(#31). (G : ground)
G	<ul style="list-style-type: none"> There are a number of cross lines. A crossing having a dot as in " $\overset{A}{\cdot}$ " means that the lines A and B are connected to each other. On the other hand, a crossing having no dot indicates that the lines A and B are separate lines.
H	<ul style="list-style-type: none"> This section indicates the body ground Connection. so, there is no wire ground like Gxxx.

1-2. POWER SUPPLY NUMBER

NUMBER	CONTENTS
30	<ul style="list-style-type: none"> The battery(+) line.
15	<ul style="list-style-type: none"> Electric power is supplied when the starter switch is turned to the "ON" position before the engine starts.
15A	<ul style="list-style-type: none"> Electric power is supplied when the starter switch is turned to the "ACC" position.
15B	<ul style="list-style-type: none"> Electric power is supplied from the starter switch "ON" relay #87.
58	<ul style="list-style-type: none"> #58 is switched ON when the head lamp switch is ON.

1-3. COLOR SYMBOLS FOR WIRING

- To make it easy to read the circuit diagram, each wiring is given a unique color on the circuit diagram.

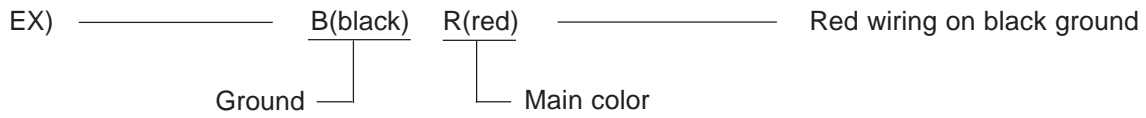

SYMBOL	COLOR	SYMBOL	COLOR	SYMBOL	COLOR
R	Red	Y	Yellow	L	Blue
B	Black	Lg	Yellowish green	V	Vilocet
Br	Brown	Gr	Gray	O	Orange
W	White	G	Green	P	Pink

1-4. HOW TO KNOW CONNECTOR PIN NUMBER

1) CONNECTOR PIN FIGURE

Connector pin figure is the total hole number of the connector

2) CONNECTOR PIN NUMBER

EX) NO.4 of the 6 pin connector

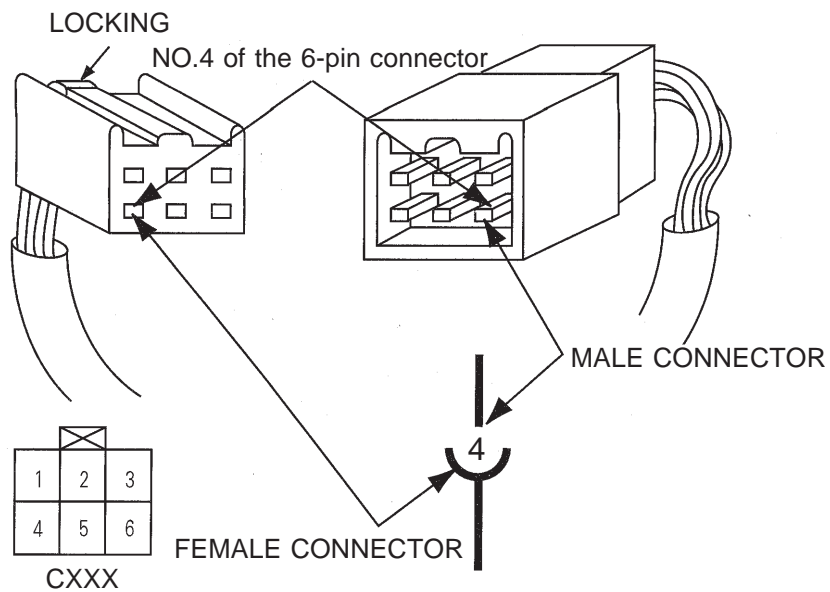

2. LOCATIONS OF ELECTRICAL HARNESSSES

2-1. ROOF HARNESS/ DASH HARNESS/ DOOR HARNESS

2-1-a. ROOF HARNESS

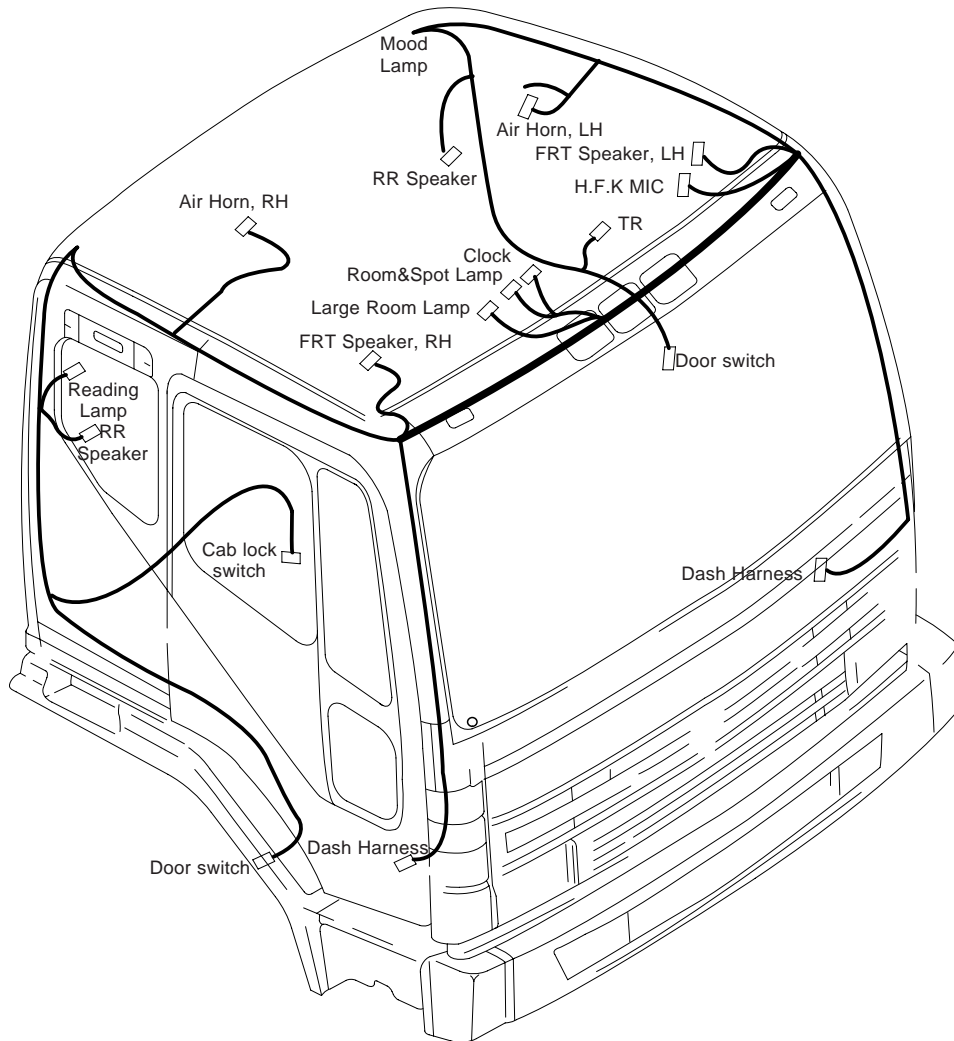

EL001

2-1-b. DASH HARNESS (DE/DV)

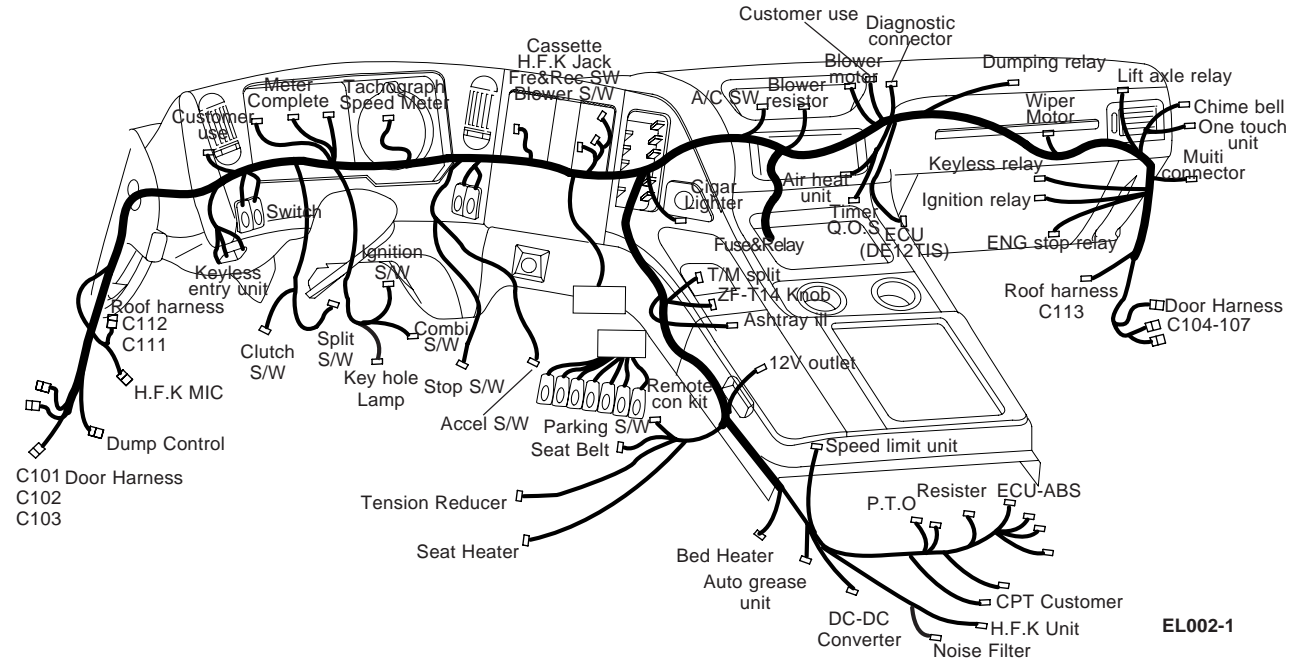

ALLISON (AUTO T/M)

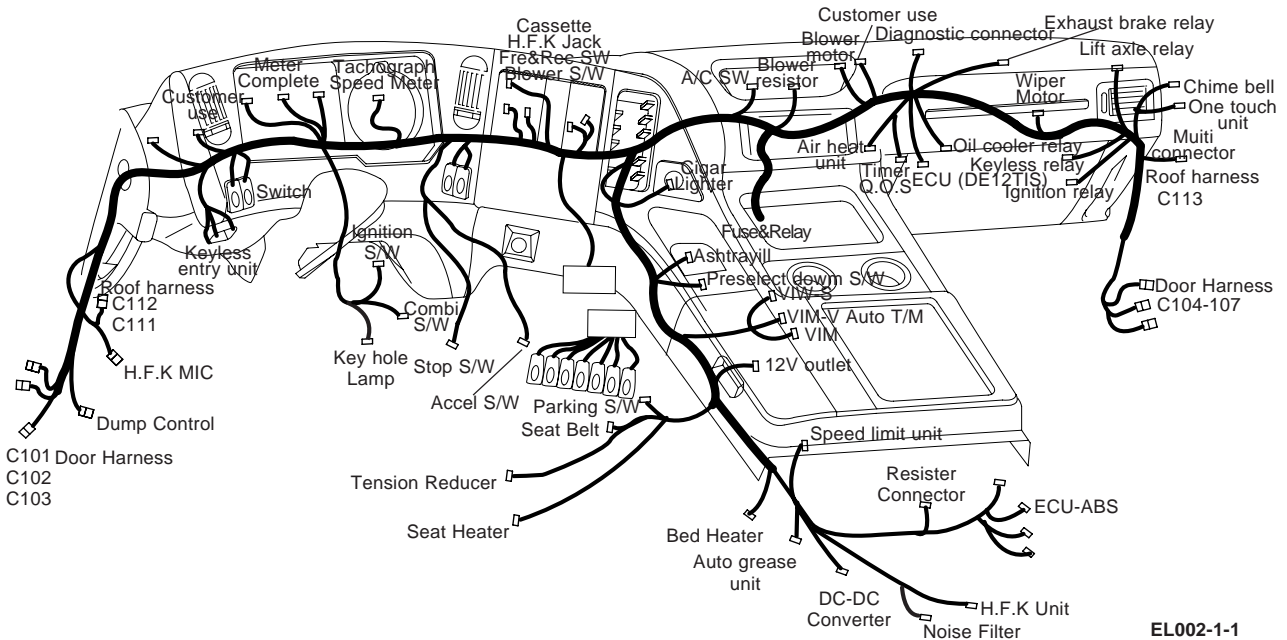

1. GENERAL DESCRIPTIONS

2-1-c. DOOR HARNESS

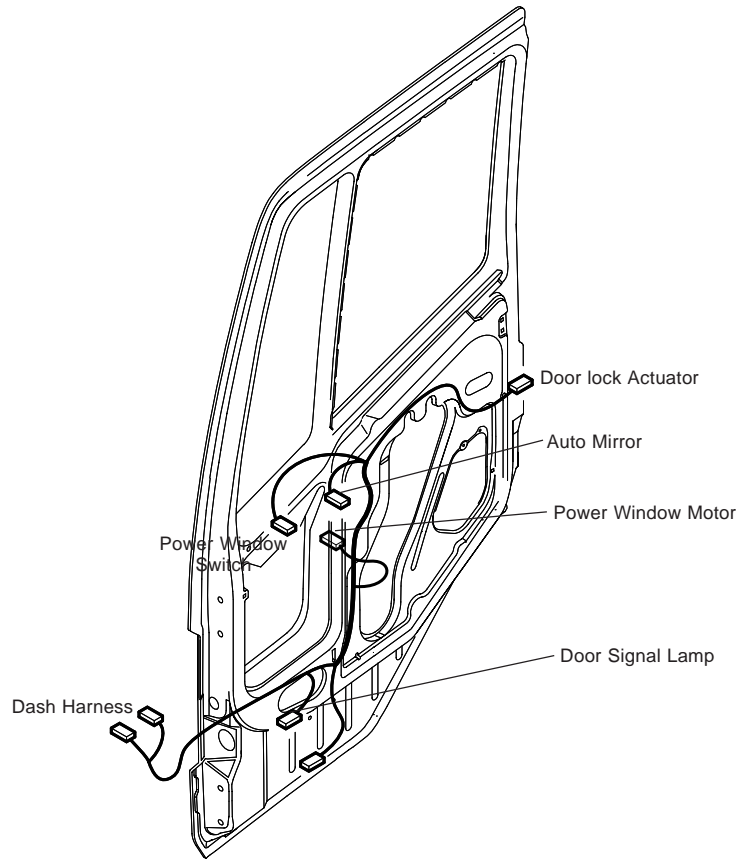

EL002-4

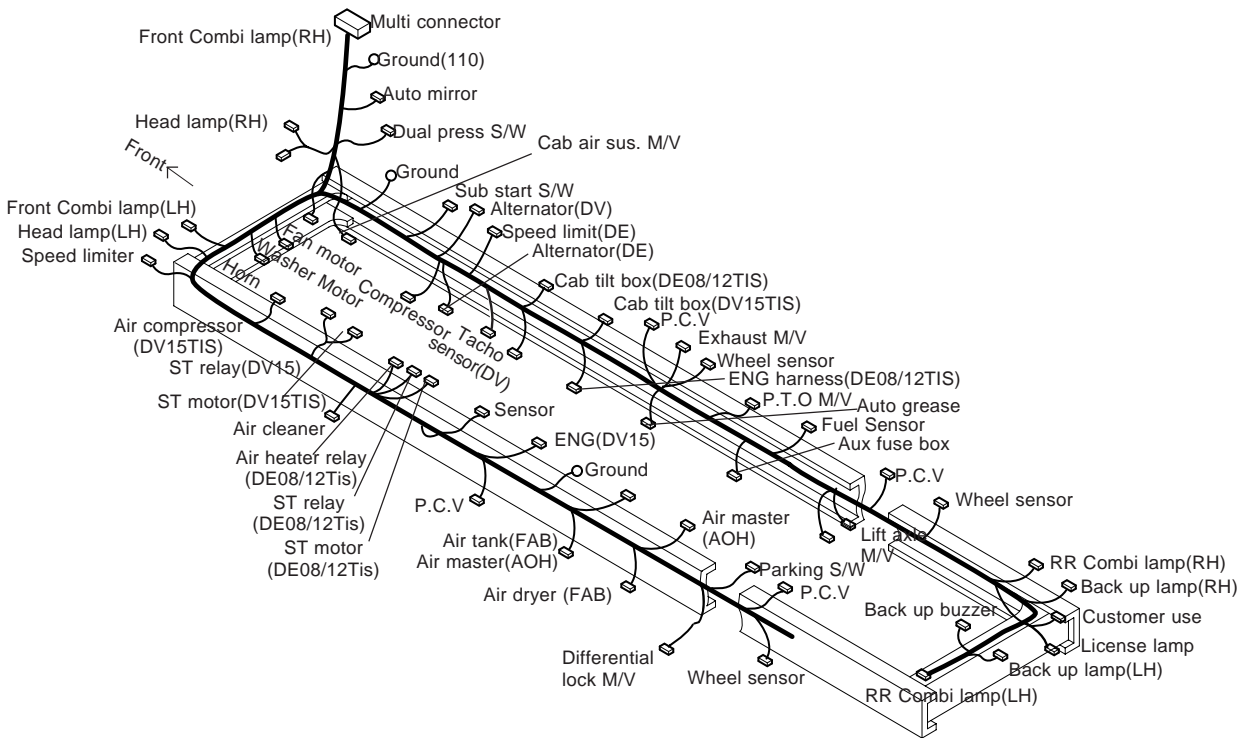

2-2. FRAME HARNESS (DE/DV)





EL005-1

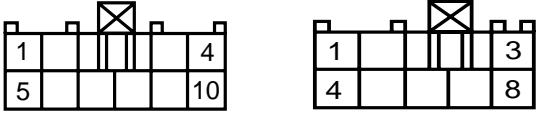
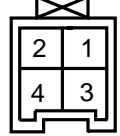

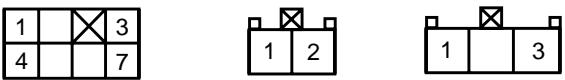
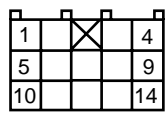
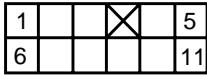
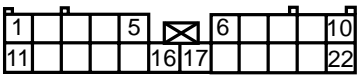

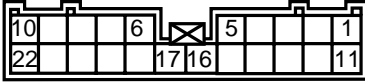
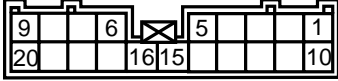
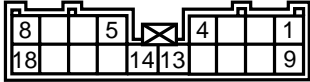

* The location of harness is different by the vehicle type.

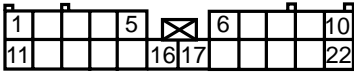
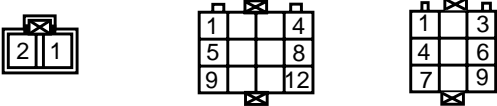
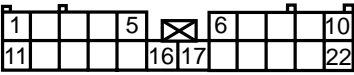
2-3. CONNECTOR CONDITION

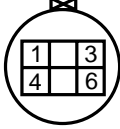
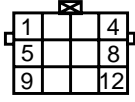
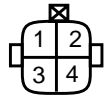
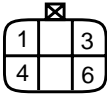
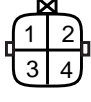
<p>Connector for dash harness and driver's seat door harness</p>  <p>C101(10pin) C102(8pin)</p> <p>Based on dash harness</p>	<p>Connector for dash harness and driver's seat door harness</p>  <p>C103(4pin)</p> <p>Based on dash harness</p>
<p>Connector for dash harness and assist seat door harness</p>  <p>C104(8pin) C105(4pin)</p> <p>Based on dash harness</p>	<p>Connector for dash harness and assist seat door harness</p>  <p>C106(4pin) C107(2pin)</p> <p>Based on dash harness</p>
<p>Connector for dash harness and driver's seat roof harness</p>  <p>C111(7pin) C112(2pin) C114 H.F.K MIC</p> <p>Based on dash harness</p>	<p>Connector for dash harness and assist seat roof harness</p>  <p>C113(14pin)</p> <p>Based on dash harness</p>
<p>Connector for dash harness and tachograph harness</p>  <p>C121(11pin)</p> <p>Based on dash harness</p>	<p>Connector for dash harness and switch harness</p>  <p>C131(22pin)</p> <p>Based on dash harness</p>

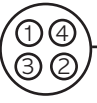
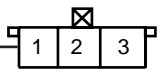
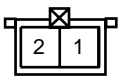
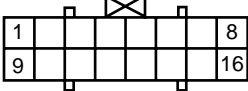
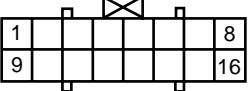
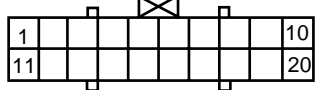
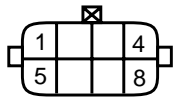



1. GENERAL DESCRIPTIONS

<p>Connector for dash harness and frame harness</p>  <p>C201(22pin) Based on dash harness</p>	<p>Connector for dash harness and frame harness</p>  <p>C202(20pin) Based on dash harness</p>
<p>Connector for dash harness and frame harness</p>  <p>C203(18pin) Based on dash harness</p>	<p>Connector for dash harness and frame harness</p>  <p>C204(12pin) C205(4pin) Speed sensor Based on dash harness</p>
<p>Connector for dash harness and frame harness</p>  <p>C206(4pin) C207(2pin) C208(1pin) Based on dash harness</p>	<p>Connector for dash harness and frame harness</p>  <p>C209(22pin) ECM(ABS) Based on dash harness</p>
<p>Connector for dash harness and frame harness</p>  <p>C210(2pin) ABS for trailer C211(12pin) C212(9pin) Based on dash harness</p>	<p>Connector for dash harness and frame harness</p>  <p>C213(22pin) ECM(ABS/ASR) Based on dash harness</p>

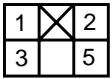
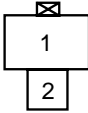
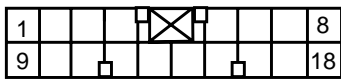
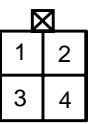
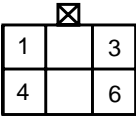
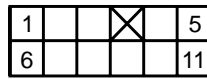
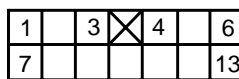
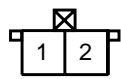
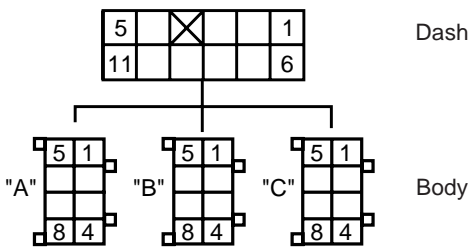
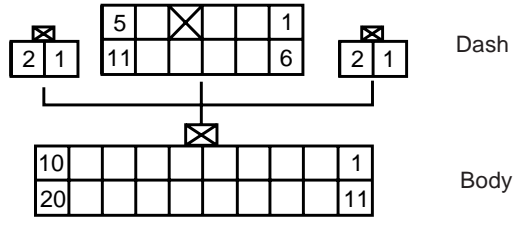
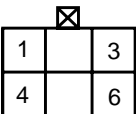
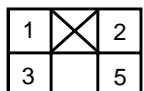
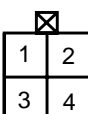
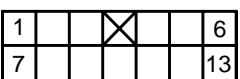
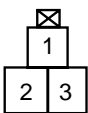

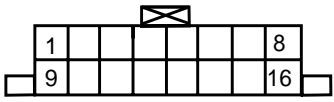
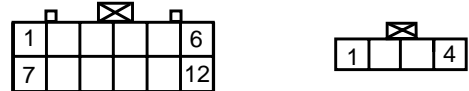

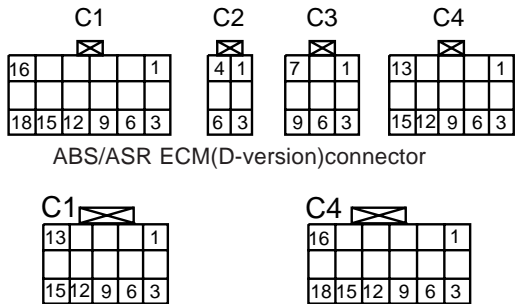
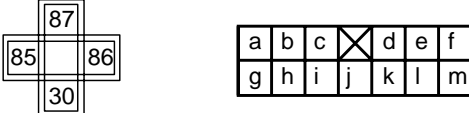

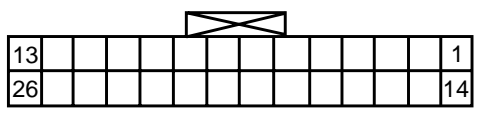
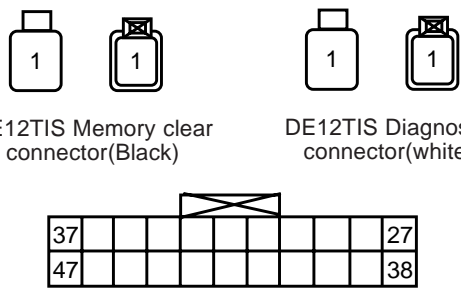
<p>Connector for engine harness and frame harness</p>	<p>Connector for frame harness and engine harness</p>
<div style="text-align: center;">  <p>C302(6pin) Split</p> <p>Based on frame harness</p> </div>	<div style="display: flex; justify-content: space-around; align-items: center;"> <div style="text-align: center;">  <p>C311(12pin)</p> </div> <div style="text-align: center;">  <p>C312(4pin) Speed sensor</p> </div> </div> <p style="text-align: center;">Based on frame harness</p>
<p>Connector for frame harness and trailer harness</p>	<p>Connector for frame harness and trailer harness</p>
<div style="text-align: center;">  <p>C401(6pin)</p> <p>Based on frame harness</p> </div>	<div style="display: flex; justify-content: space-around; align-items: center;"> <div style="text-align: center;">  <p>C402(4pin) ABS</p> </div> <div style="text-align: center;">  <p>C403(1pin) ABS</p> </div> <div style="text-align: center;">  <p>C404(1pin) ABS</p> </div> </div> <p style="text-align: center;">Based on frame harness</p>
<p>Connector for frame harness and ABS PCV harness</p>	<p>Connector for dash harness and instrument harness</p>
<div style="display: flex; justify-content: space-around; align-items: center;"> <div style="text-align: center;">  <p>P.C.V</p> </div> <div style="text-align: center;">  <p>C501~504</p> </div> <div style="text-align: center;">  <p>Wheel Speed sensor</p> </div> </div> <p style="text-align: center;">Based on frame harness</p>	<div style="display: flex; justify-content: space-around; align-items: center;"> <div style="text-align: center;">  <p>A(White)</p> </div> <div style="text-align: center;">  <p>B(Black)</p> </div> </div> <div style="text-align: center; margin-top: 20px;">  <p>C(White)</p> <p>Based on dash harness</p> </div>
<p>Connector for frame harness and auxiliary fuse box harness</p>	<p>Connector for frame harness and auxiliary fuse box harness</p>
<div style="display: flex; justify-content: space-around; align-items: center;"> <div style="text-align: center;">  <p>C601(8pin)</p> </div> <div style="text-align: center;">  <p>C602(2pin)</p> </div> </div> <p style="text-align: center;">Based on frame harness</p>	<div style="display: flex; justify-content: space-around; align-items: center;"> <div style="text-align: center;">  <p>C603(1pin) KEY ON Power : Green</p> </div> <div style="text-align: center;">  <p>C604(1pin) B+ Power</p> </div> <div style="text-align: center;">  <p>C605(1pin) Trailer ABS Power (tractor/Pull Cargo) : Blue</p> </div> </div> <p style="text-align: center;">Based on frame harness</p>



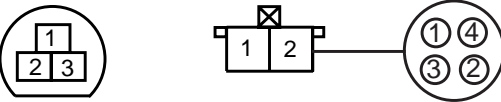

1. GENERAL DESCRIPTIONS

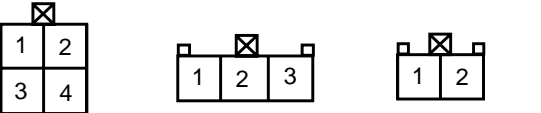
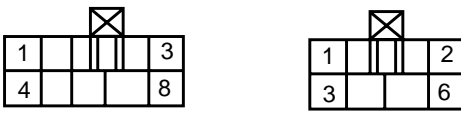
 <p>Facia Switch Connector</p>  <p>Customer service/Clutch/ Stop SW/Cigar lighter /Seat connector</p> <p>Based on dash harness</p>	 <p>Keyless unit connector</p> <p>Based on dash harness</p>
 <p>Ignition switch (Engine stop motor)</p>  <p>Ignition switch (Sub starter)</p> <p>Based on dash harness</p>	 <p>Combination wiper S/W (RH)</p>  <p>Combination light S/W (LH)</p>  <p>Key hole lamp</p> <p>Based on dash harness</p>
 <p>Dash</p> <p>Body</p> <p>VDO Tachograph connector (behind instrument)</p>	 <p>Dash</p> <p>Body</p> <p>CASPO Digital tachograph connector (behind instrument)</p>
 <p>Blower switch</p>  <p>Fre&Rec switch</p>  <p>Blower resistor switch</p> <p>Based on dash harness</p>	 <p>One touch unit</p>  <p>DC-DC converter/ ZF-T14 knob/ T/M Splitter connector</p> <p>Based on dash harness</p>



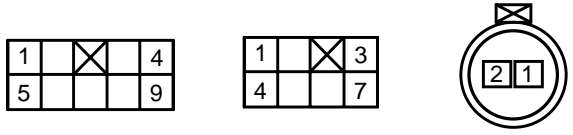
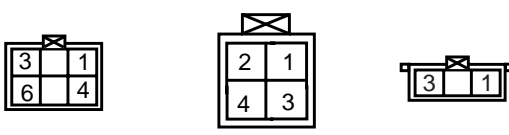
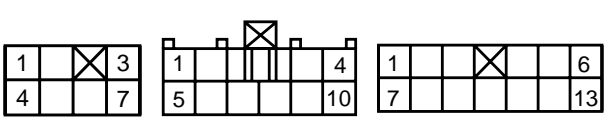



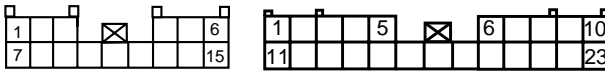

 <p>Diagnostic connector</p> <p>Based on dash harness</p>	 <p>H.F.K unit H.F.K jack</p> <p>Based on dash harness</p>
 <p>Air heat unit Timer Q.O.S unit</p> <p>Based on dash harness</p>	 <p>C1 C2 C3 C4</p> <p>ABS/ASR ECM(D-version)connector</p> <p>C1 C4</p> <p>ABS/ASR ECM(E-Version, D-version basic)connector</p> <p>Based on dash harness</p>
 <p>Starter switch "ON"/Keyless relay connector (Inside groove box) Chime bell connector</p> <p>Based on dash harness</p>	 <p>Wiper motor connector Bed-heater</p> <p>Based on dash harness</p>
 <p>DE12TIS ECM Frame harness(connector)</p> <p>Based on dash harness</p>	 <p>DE12TIS Memory clear connector(Black) DE12TIS Diagnostic connector(white)</p> <p>DE12TIS ECM dash harness(connector)</p> <p>Based on dash harness</p>

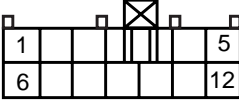
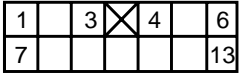
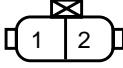

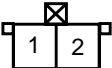

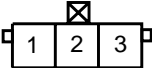
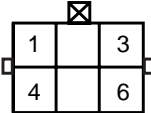
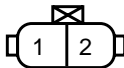
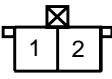
1. GENERAL DESCRIPTIONS

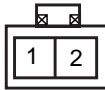
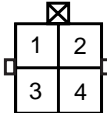
 <p>Wiper intermittent/ Door lock/ mirror heater unit</p> <p>Key hole lamp unit</p> <p>Fuse relay box</p>	 <p>FRT/RR combination lamp</p> <p>Head lamp connector</p> <p>Based on frame harness</p>
 <p>Engine stop motor connector</p> <p>ASR valve connector</p> <p>Based on frame harness</p>	 <p>ABS pressure control valve connector</p> <p>Air dryer connector</p> <p>Based on frame harness</p>
 <p>Clock connector</p> <p>Room/Spot connector</p> <p>Large room lamp connector</p> <p>Based on roof harness</p>	 <p>Auto mirror switch connector</p> <p>Mirror heater/ mirror motor connector</p> <p>Based on door harness</p>
 <p>Air horn</p> <p>Cab lock S/W</p> <p>Based on roof harness</p>	 <p>Seat belt tension reducer /Speaker connector</p> <p>Reading/Mood lamp connector</p> <p>Based on roof harness</p>

 <p>Driver seat power window switch Assist seat power window switch Power window motor connector</p> <p>Based on door harness</p>	 <p>Prestroke actuator & sensor Rack sensor NE(Pick-up) sensor</p> <p>DE12TIS Engine Based on Frame harness</p>
 <p>VIW-S VIW-V VIM</p> <p>Based on dash harness(Auto T/M)</p>	 <p>Exhaust brake relay T/M oil cooler relay</p> <p>Based on dash harness</p>
 <p>Auto grease / Pump connector Dual pressure S/W Temperature S/W</p> <p>Based on frame harness</p>	 <p>Cab tilt motor Chime bell Cab tilt PBS switch</p> <p>Cab tilt box Based on frame harness</p>
 <p>Exhaust brake/Preselect down switch Auto grease unit</p> <p>Based on dash harness</p>	 <p>PTO Actuator PTO Controller</p> <p>Based on dash harness</p>

1. GENERAL DESCRIPTIONS

 <p>Speed limit unit</p>  <p>Cassette</p> <p>Based on dash harness</p>	 <p>Resistor 120 ohm</p> <p>Based on dash harness</p>
 <p>ZF</p>  <p>T14</p> <p>T/M Split high switch</p> <p>Based on engine harness</p>	 <p>Neutral/ Back up lamp</p>  <p>Air heater relay</p> <p>Based on engine harness</p>
 <p>Limit switch</p>  <p>Step motor</p> <p>ESCS actuator connector</p> <p>Based on frame harness</p>	 <p>Back up/Keyless buzzer connector</p>  <p>Back up lamp/ License lamp</p> <p>Based on frame harness</p>
 <p>Water pump relay</p>  <p>Preheater relay</p> <p>Based on frame harness</p>	 <p>A</p>  <p>B</p>  <p>C</p> <p>Switch box</p> <p>Based on frame harness</p>

<div style="display: flex; justify-content: space-around; align-items: center;"> <div style="text-align: center;">  <p>T/M oil temp switch</p> </div> <div style="text-align: center;">  <p>T/M oil cooler</p> </div> </div> <p style="text-align: center; margin-top: 20px;">Based on frame harness</p>	<div style="display: flex; justify-content: space-around; align-items: center;"> <div style="text-align: center;">  <p>Door lock actuator</p> </div> <div style="text-align: center;">  <p>Door turn signal lamp</p> </div> </div> <p style="text-align: center; margin-top: 20px;">Based on door harness</p>

2-4. LOCATIONS OF GROUND CONNECTIONS

2-4-a. DASH HARNESS

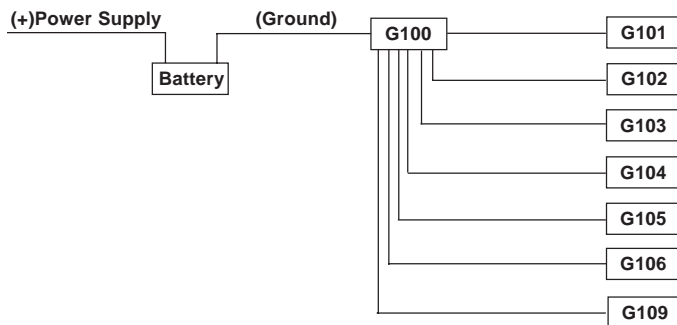
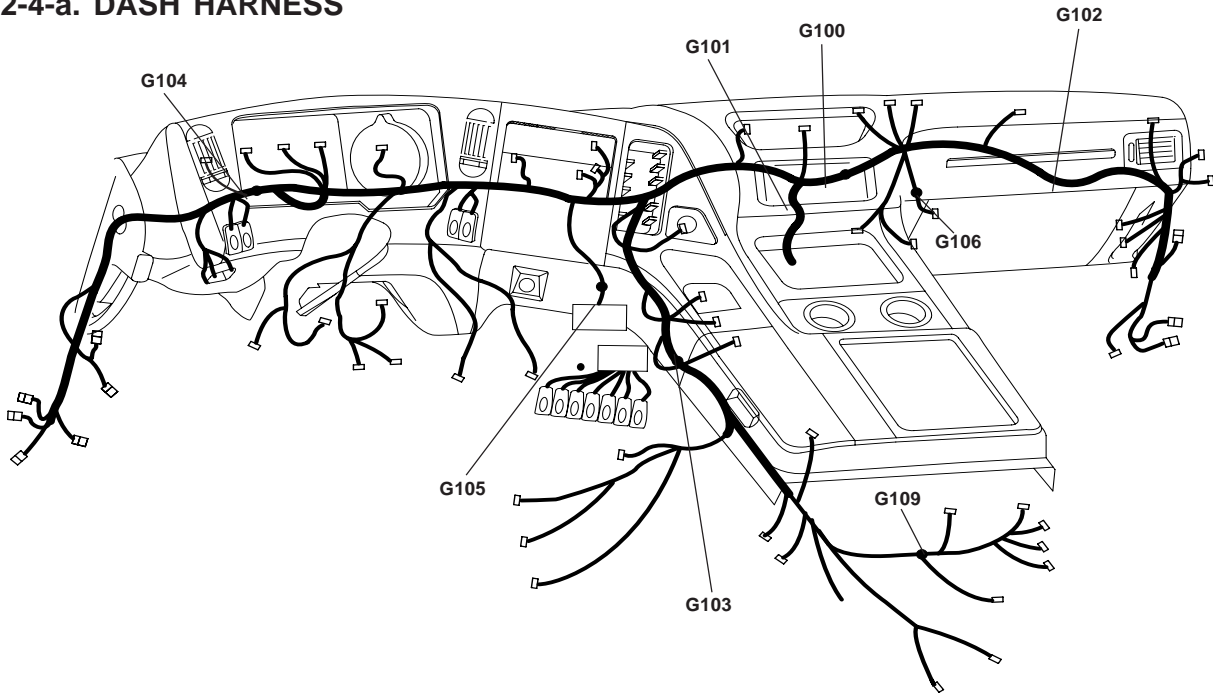

EL002-2

Ground No	Location of the ground earth connector wiring
G100	Near the blower motor
G101	Near the blower motor
G102	Near the wiper motor on passenger's side
G103	Near the bed heater behind the passenger seat
G104	Near the clutch pedal switch
G105	Near the switch connector wiring at the right side of the driver's seat
G106	Near the ECU (DE12TIS)
G109	Near the PTO unit

2-4-b. FRAME HARNESS**CAB GROUND**

This is located at the right, upper end of the front lid.

It is fastened firmly to the wiper motor housing cover.

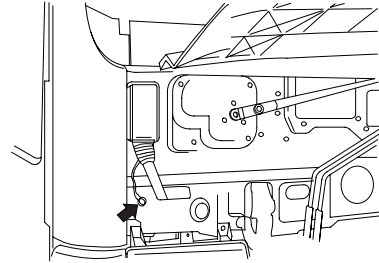
**FRAME GROUND (DRIVER'S SEAT)**

This is located inward the left frame .

It is fasted to the inner frame of the battery

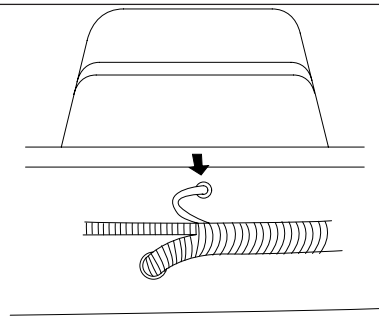
**FRAME GROUND (ASSIST SEAT)**

This is located inward the right frame :

It is fstened to the inner frame of the receiver dryer

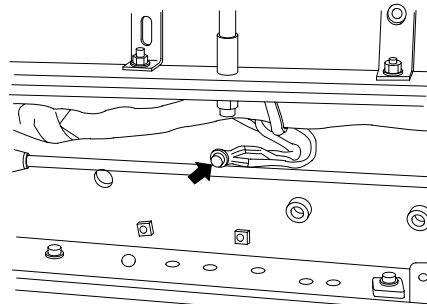
**AUX. FUSE BOX GROUND**

This is located outward the aux fuse box frame.

It is fastened to the outer frame of the aux fuse box.

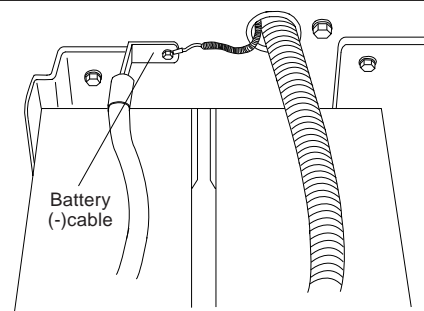

2-5. FUSE AND RELAY LAYOUT

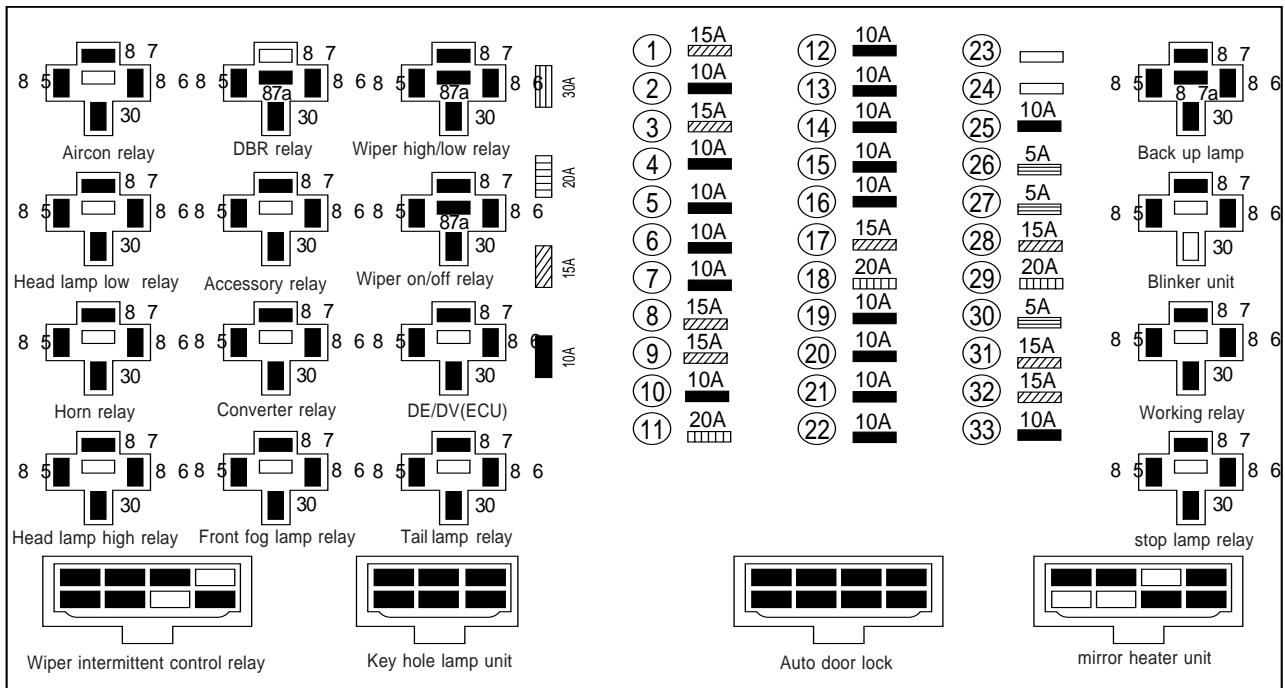

Fuse No	Capacity	Description	Fuse No	Capacity	Description
F1	15A	Ignition switch, Meter, Tachograph	F18	20A	Air con, Blower motor, Fre & Rec SW
F2	10A	Large Room lamp, Door step lamp, Keyhole unit, Diagnosis	F19	10A	Cab tilt, Cab lock SW
F3	15A	DC-DC converter	F20	10A	Preheater U, Key hole lamp, Seat belt
F4	10A	Clock(B+),Cassette(B+),Noise Fitter	F21	10A	Cassette, clock, Hands free kit unit
F5	10A	Engine stop motor, Key box	F22	10A	Bed heater, Cigar, Seat heater
F6	15A	ABS C1-8(ABS/ASR:10A, ABS:15A)	F23		T/M oil cooler(Auto T/M), Customer service
F7	10A	ABS C1-9	F24		Customer service
F8	15A	Blinker unit	F25	10A	Auto grease unit
F9	15A	Door lock,Horn,Keyless,Keyhole lamp,Auto T/M(E-module)	F26	5A	ABS C1-7, DBR Relay
F10	10A	Fog lamp relay	F27	5A	Trailer ABS(IGN+)
F11	20A	Dual one touch unit	F28	15A	Wiper system, Combi SW
F12	10A	Power window switch, Mirror heater unit/switch	F29	20A	DE12TIS Power R #30
F13	10A	PTO, Diff lock(L/R), Split, Dump control, Lift axle, ELM	F30	5A	ECM memory clear C, Prest R, ECM Power R #85 Air heater R(DE12TIS)
F14	15A	Differential lock(F/R), ZF-T14 Knob, Lock brake SW, Buzzer unit	F31	15A	Head lamp high R #30/85
F15	10A	Stop lamp, Auxiliary fuse box	F32	15A	Head lamp low R #30/85
F16	10A	Reverse R/S, Water pump switch	F33	10A	Tail lamp R #30/85
F17	15A	Working lamp switch/relay			

2-6. AUXILIARY FUSE AND RELAY BOX

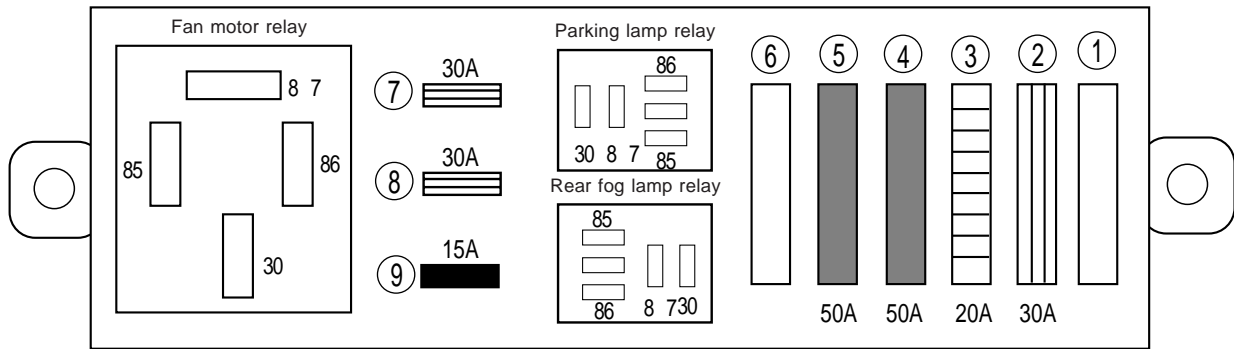

Fuse No	Capacity	Description	Fuse No	Capacity	Description
1			6		
2	30(A)	The room fuse #31 - #33 B+(light)	7	30(A)	Cab tilt box B+
3	20(A)	Trailer ABS B+	8	30(A)	Mixer switch box B+
4	50(A)	Starter switch "IG" relay #30	9	15(A)	Condenser fan motor relay #30
5	50(A)	The room fuse #1 - #11,23,24 B+ Accessory Relay #30			

2-7. THE OTHERS RELAY

1. IG relay
2. Keyless relay
3. Engine stop relay
4. Lift axle relay
5. Dumping relay

SECTION 2

CIRCUIT DIAGRAMS BY SYSTEMS

1.	STARTER MOTOR AND STARTER SWITCH " ACC" CIRCUIT DIAGRAM.....	26
2.	CHARGING AND STARTER SWITCH " ON" /ENGINE STOP MOTOR CIRCUIT DIAGRAM.....	28
3.	LIGHT CIRCUIT DIAGRAM	30
4.	HEATING SYSTEM CIRCUIT DIAGRAM	32
5.	12V CONVERTER, CIGAR LIGHTER, BED HEATER, SEAT HEATER CIRCUIT DIAGRAM	34
6.	BACK UP LAMP CIRCUIT DIAGRAM	36
7.	CAB TILT (MECHANIC), CHIME BELL CIRCUIT DIAGRAM	38
8.	CAB TILT (HYDRAULIC), CHIME BELL CIRCUIT DIAGRAM	40
9.	P.T.O, FOG LAMP CIRCUIT DIAGRAM	42
10.	STOP LAMP, TRAILER STOP LAMP CIRCUIT DIAGRAM	44
11.	CLEARANCE, LICENSE PLATE, ASHTRAY, AIR HORN LAMP CIRCUIT DIAGRAM	46
12.	PARKING LAMP CIRCUIT DIAGRAM	48
13.	SEAT BELT TENSION REDUCER, STEP LAMP, LARGE ROOM LAMP, READING/ MOOD LAMP CIRCUIT DIAGRAM	50
14.	KEY HOLE ILLUMINATION LAMP, ROOM & SPOT LAMP CIRCUIT DIAGRAM	52
15.	TURN SIGNAL LAMP, HAZARD WARNING LAMP CIRCUIT DIAGRAM.....	54
16.	CORNERING LAMP, AUTO GREASE CIRCUIT DIAGRAM	56
17.	CASSETTE, DIGITAL CLOCK CIRCUIT DIAGRAM	58
18.	DOOR LOCKING DEVICE, HORN CIRCUIT DIAGRAM.....	60
19.	KEYLESS ENTRY SYSTEM CIRCUIT DIAGRAM	62
20.	EXHAUST BRAKE, DBR CIRCUIT DIAGRAM	64
21.	SPLIT SYSTEM(ZF T/M, T-14 T/M) CIRCUIT DIAGRAM.....	66
22.	POWER WINDOW CIRCUIT DIAGRAM	68
23.	WIPER CIRCUIT DIAGRAM	70
24.	AUTO MIRROR AND MIRROR HEATER CIRCUIT DIAGRAM	72
25.	TACHOGRAPH CIRCUIT DIAGRAM (VDO, CASPO).....	74
26.	HEATER, AIR CONDITIONER CIRCUIT DIAGRAM	76
27.	SPEED LIMITER CIRCUIT DIAGRAM.....	78
28.	LOCK BRAKE, DIFFERENTIAL LOCK CIRCUIT DIAGRAM (EXCEPT HUB REDUCTION)	80
29.	DIFFERENTIAL LOCK(HUB REDUCTION) CIRCUIT DIAGRAM	82

30. WATER PUMP-MIXER DRUM CIRCUIT DIAGRAM.....	84
31. WORKING LAMP, AIR DRYER HEATER CIRCUIT DIAGRAM.....	86
32. TRAILER CONNECTOR CIRCUIT DIAGRAM	88
33. LIFT AXLE CIRCUIT DIAGRAM	90
34. ABS/ASR ELECTRIC CIRCUIT DIAGRAM(D-VERSION)	92
34-1. ABS/ASR PRESSURE CONTROL VALVE, WHEEL SPEED SENSOR CIRCUIT DIAGRAM (4 SENSOR / 4 CHANNEL).....	94
34-2. ABS/ASR PRESSURE CONTROL VALVE, WHEEL SPEED SENSOR CIRCUIT DIAGRAM (4 SENSOR / 3 CHANNEL).....	96
35. ABS ELECTRIC CIRCUIT DIAGRAM(D-VERSION BASIC)	98
35-1. ABS PRESSURE CONTROL VALVE, WHEEL SPEED SENSOR CIRCUIT DIAGRAM .	100
36. TRAILER ABS CIRCUIT DIAGRAM	102
37. ABS BLINKCODE DESCRIPTION	104
38. SERVICE ELECTRIC EQUIPMENTS FOR USER CIRCUIT DIAGRAM	110
39. DE12TIS ECM POWER, RACK SENSOR, RPM SENSOR CIRCUIT DIAGRAM	112
40. DE12TIS DIAGNOSTIC, PREST SENSOR AND ACTUATOR CIRCUIT DIAGRAM	114
41. INSTRUMENT SYSTEM CIRCUIT DIAGRAM	116
41-1. INSTRUMENT SYSTEM FOR DE ENGINE CIRCUIT DIAGRAM.....	116
41-2. INSTRUMENT SYSTEM FOR DV ENGINE CIRCUIT DIAGRAM.....	118
41-3. INDICATOR LAMP OF INSTRUMENT CIRCUIT DIAGRAM (PREHEAT, LIFT AXLE, CAB TILT ETC).....	120
41-4. INDICATOR LAMP OF INSTRUMENT CIRCUIT DIAGRAM (PTO LAMP, DIFFERENTIAL LOCK LAMP ETC)	122
41-5. SWITCH AND WARNING LAMP CIRCUIT DIAGRAM	123
41-5-1. SWITCH AND WARNING LAMP CIRCUIT DIAGRAM(FOR A.O.H).....	124
41-5-2. SWITCH AND WARNING LAMP CIRCUIT DIAGRAM(FOR F.A.B)	125
41-5-3. SWITCH AND WARNING LAMP CIRCUIT DIAGRAM	126
42. HANDS FREE KIT CIRCUIT DIAGRAM.....	128
43. ENGINE SPEED CONTROL SYSTEM (ESCS).....	130
43-1. ENGINE SPEED CONTROL SYSTEM(ESCS)	132
44. OIL COOLER CIRCUIT DIAGRAM(ALLISON AUTO TRANSMISSION)	134
44-1. AUTO TRANSMISSION OIL COOLER CIRCUIT DIAGRAM	134
44-2. AUTO TRANSMISSION OIL COOLER CIRCUIT DIAGRAM	136

1. STARTER MOTOR AND STARTER SWITCH "ACC" CIRCUIT DIAGRAM

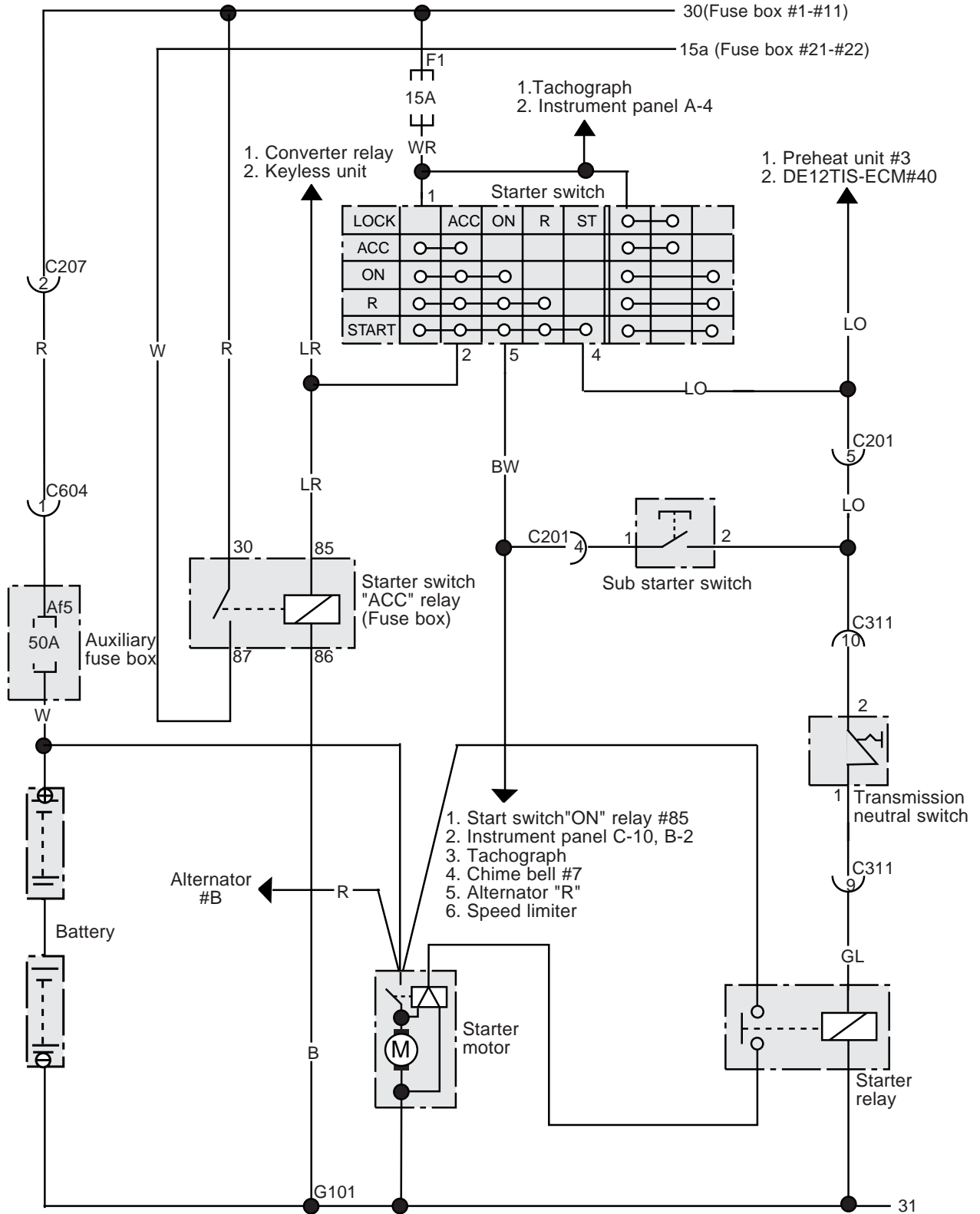

1) CONNECTOR AND PIN NUMBER

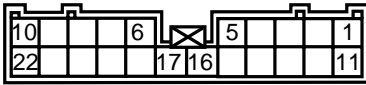

C201, 22pin

Dash - Frame harness
(Based on dash harness)



C207, 2pin

Dash - Frame harness
(Based on dash harness)

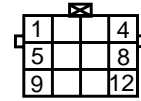

C311, 12pin

Frame - Engine harness
(Based on frame harness)



C604, 1pin

Frame - Aux fuse box
(Based on frame harness)

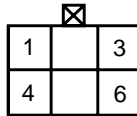

Starter switch
(Based on dash harness)

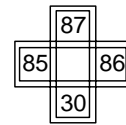

"ACC" Relay
(Fuse relay box)

2. CHARGING AND STARTER SWITCH " ON" / ENGINE STOP MOTOR CIRCUIT DIAGRAM

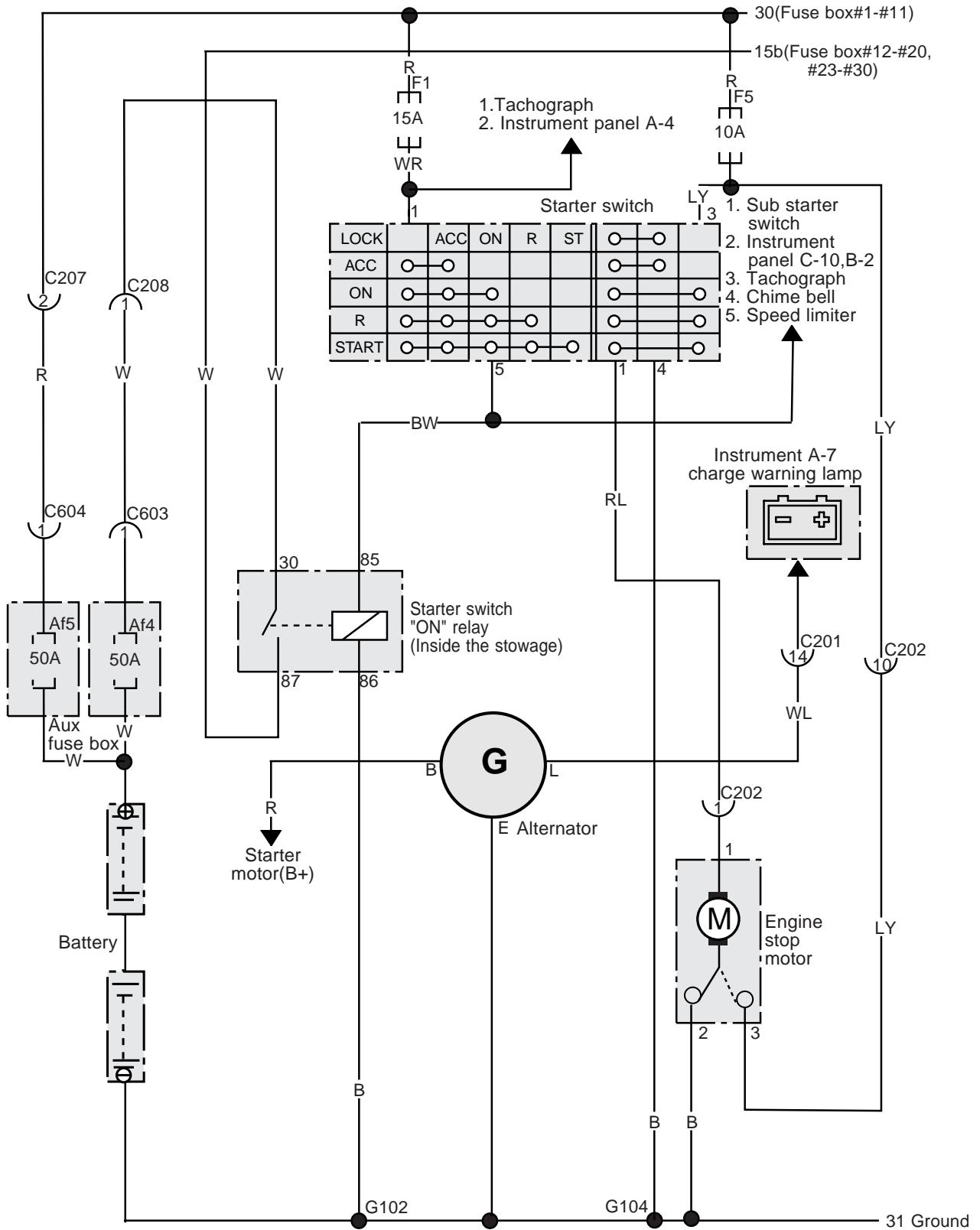

1) CONNECTOR AND PIN NUMBER

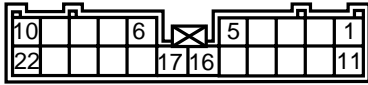

C201, 22pin

Dash - Frame harness
(Based on dash harness)

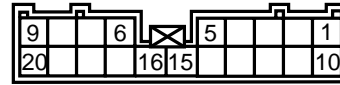

C202, 20pin

Dash - Frame harness
(Based on dash harness)



C207, 2pin

Dash - Frame harness
(Based on dash harness)



C208, 1pin

Dash - Frame harness
(Based on dash harness)



C603, 1pin

Frame - Aux fuse box
(Based on frame harness)



C604, 1pin

Frame - Aux fuse box
(Based on frame harness)

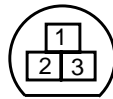

Engine stop motor
(Based on frame harness)

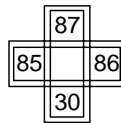

Starter S/W
"ON" relay
(Inside the stowage)

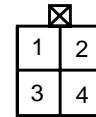

Starter switch
(Based on dash harness)

3. LIGHT CIRCUIT DIAGRAM

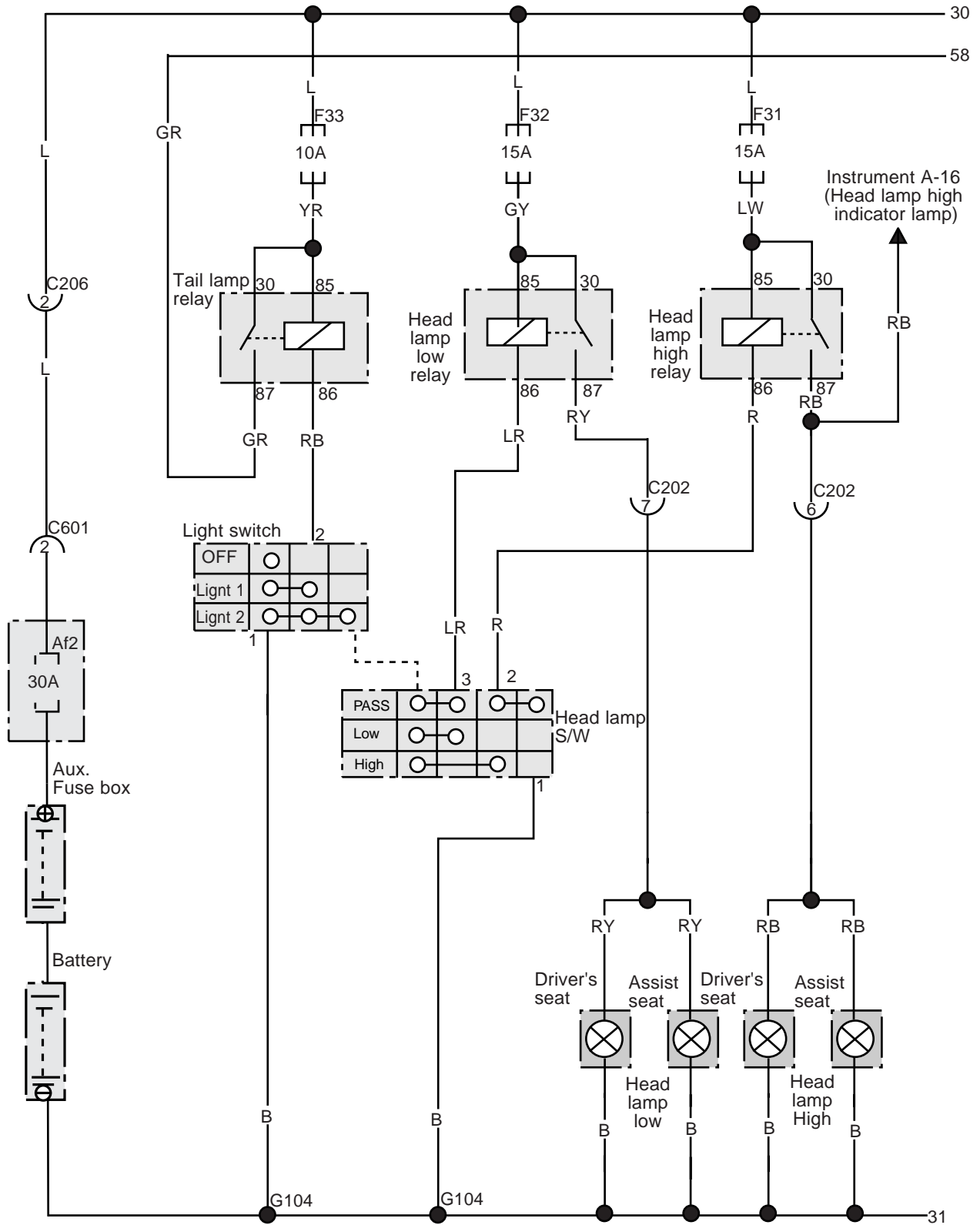

1) CONNECTOR AND PIN NUMBER

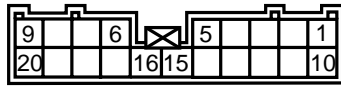

C202, 20pin

Dash - Frame harness
(Based on dash harness)

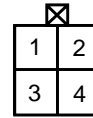

C206, 4pin

Dash - Frame harness
(Based on frame harness)

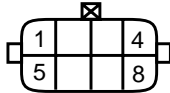

C601, 8pin

Frame - Aux fuse box harness
(Based on frame harness)

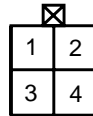

Head-Lamp high/low
(Based on frame harness)

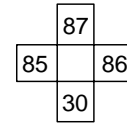

Tail lamp relay
Head lamp high
/low relay
(Fuse relay box)

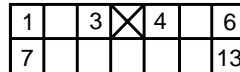
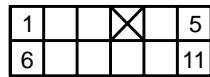

Light/head lamp combi S/W
(Based on dash harness)

4. HEATING SYSTEM CIRCUIT DIAGRAM

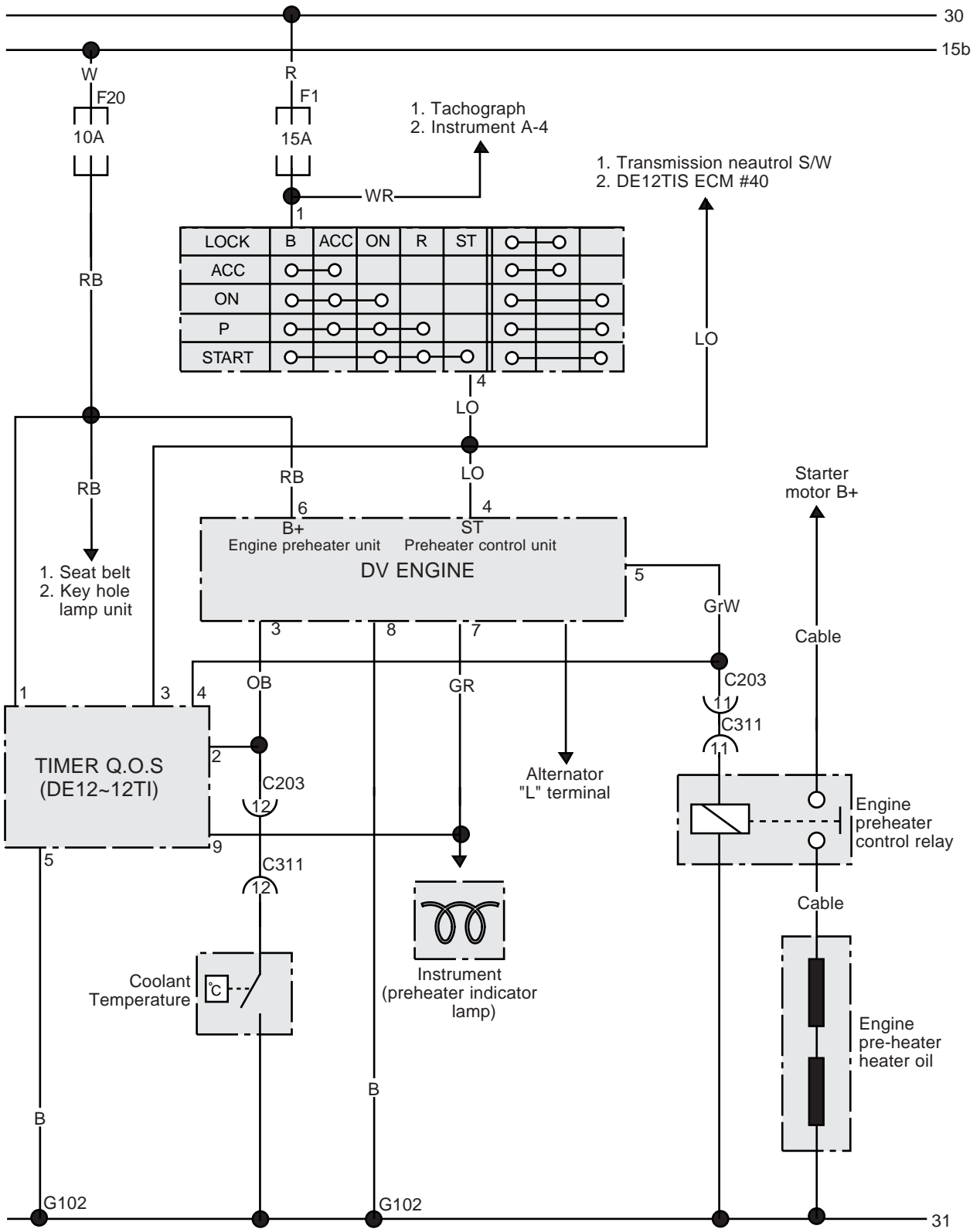

1) CONNECTOR AND PIN NUMBER

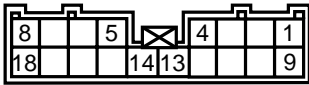

C203, 18pin
Dash - Frame harness
(Based on dash harness)

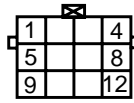

C311, 12pin
Frame - Engine harness
(Based on engine harness)



Air heater relay
(Based on engine harness)

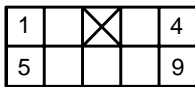

Timer Q.O.S unit
(Based on dash harness)

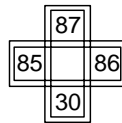

IG switch "ON" relay
(Based on dash harness)

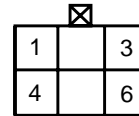

Ignition S/W
(Based on dash harness)

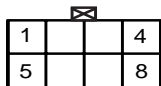

Engine preheater unit
(Based on dash harness)

**5. 12V CONVERTER, CIGAR LIGHTER, BED HEATER, SEAT HEATER
CIRCUIT DIAGRAM**

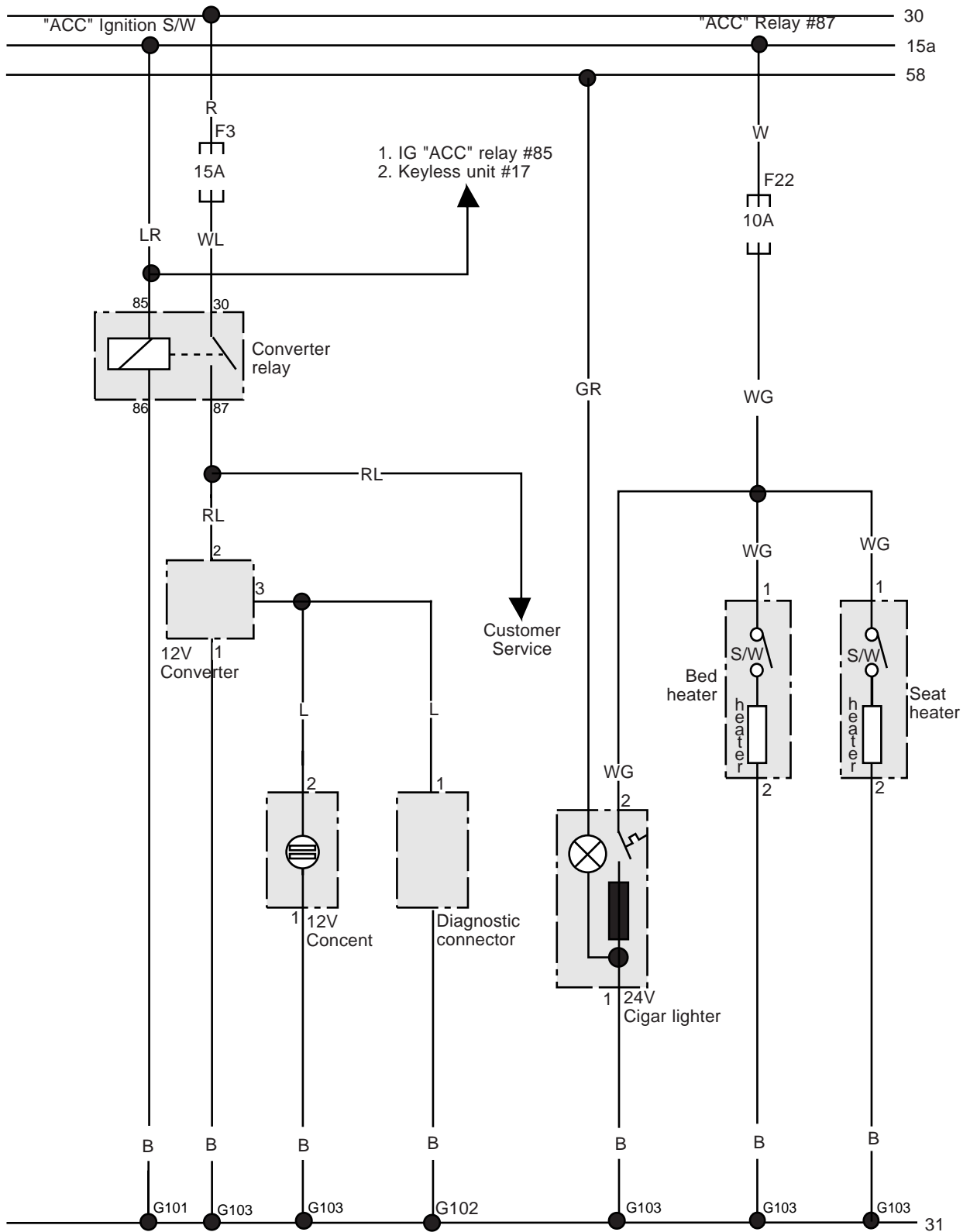

1) CONNECTOR AND PIN NUMBER

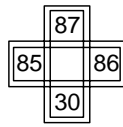

Converter relay
(fuse box)



Bed heater
(Based on dash harness)

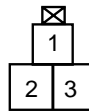

12V converter
(Based on dash harness)

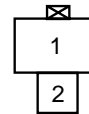

12V Concent, cigar lighter, seat heater
(Based on dash harness)

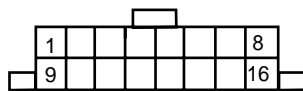

ABS Diagnostic connector
(Based on dash harness)

6. BACK UP LAMP CIRCUIT DIAGRAM

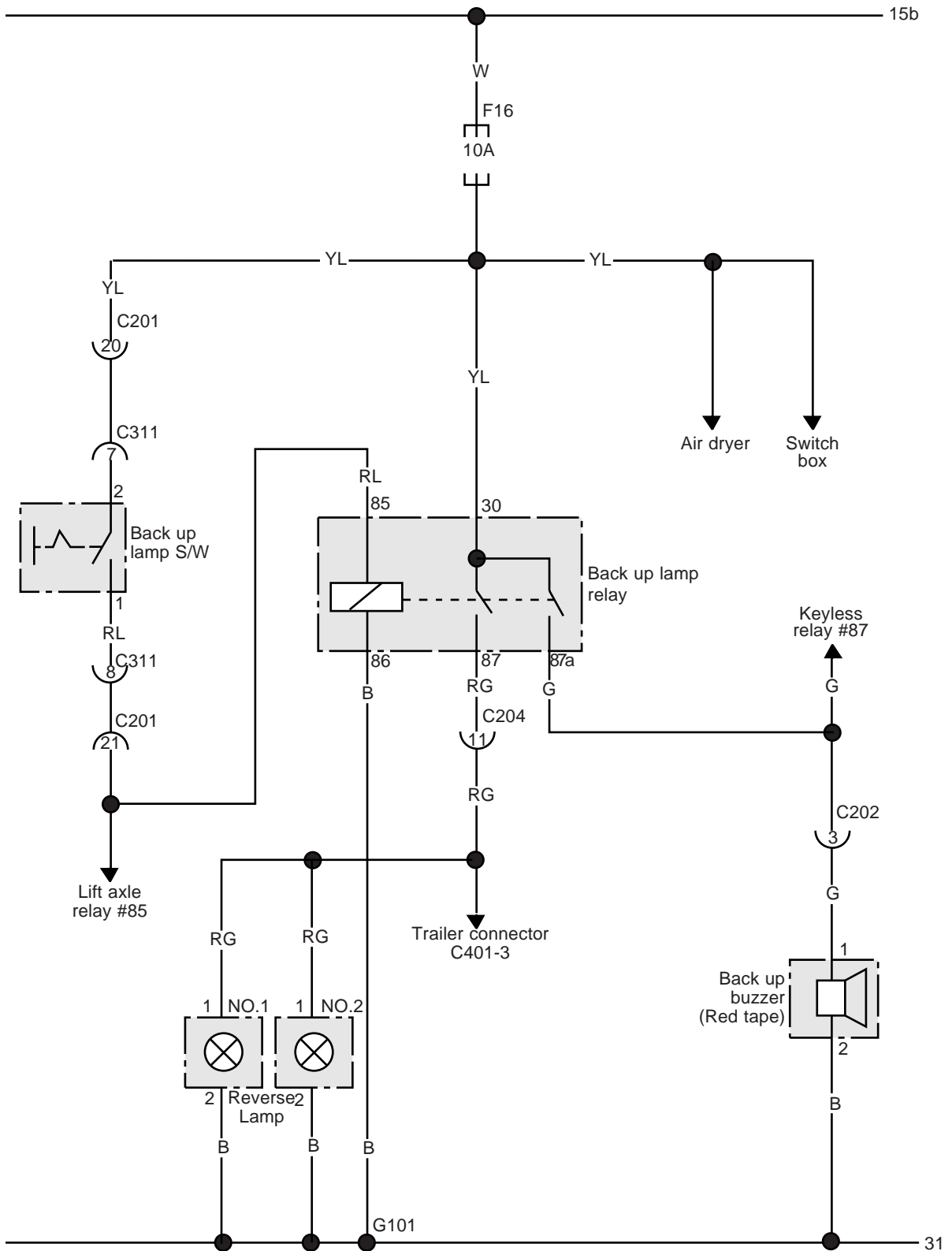

1) CONNECTOR AND PIN NUMBER

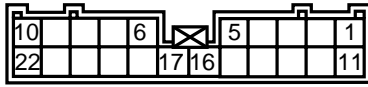

C201, 22pin

Dash - Frame harness
(Based on dash harness)

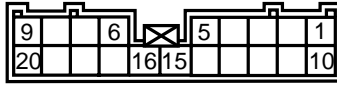

C202, 20pin

Dash - Frame harness
(Based on dash harness)

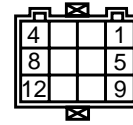

C204, 12pin

Dash - Frame harness
(Based on dash harness)

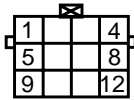

C311, 12pin

Frame - Engine harness
(Based on frame harness)

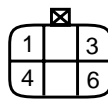

C401, 6pin

Frame - Trailer harness
(Based on frame harness)

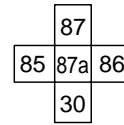

Back up lamp relay
(Fuse relay box)



Back up buzzer
(Based on frame harness)



Back up S/W
(Based on engine harness)

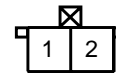

Back up lamp
(Based on frame harness)

2) LOCATION OF PARTS

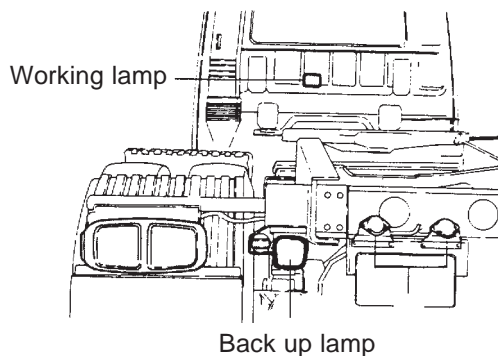

Tractor back up lamp

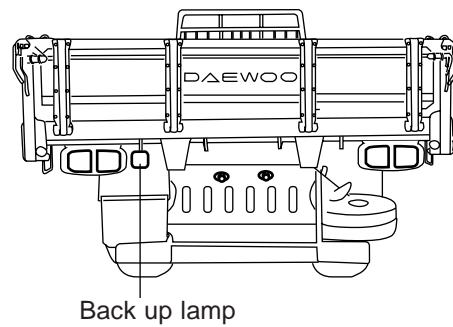

Cargo back up lamp

7. CAB TILT(MECHANIC TYPE), CHIME BELL CIRCUIT DIAGRAM

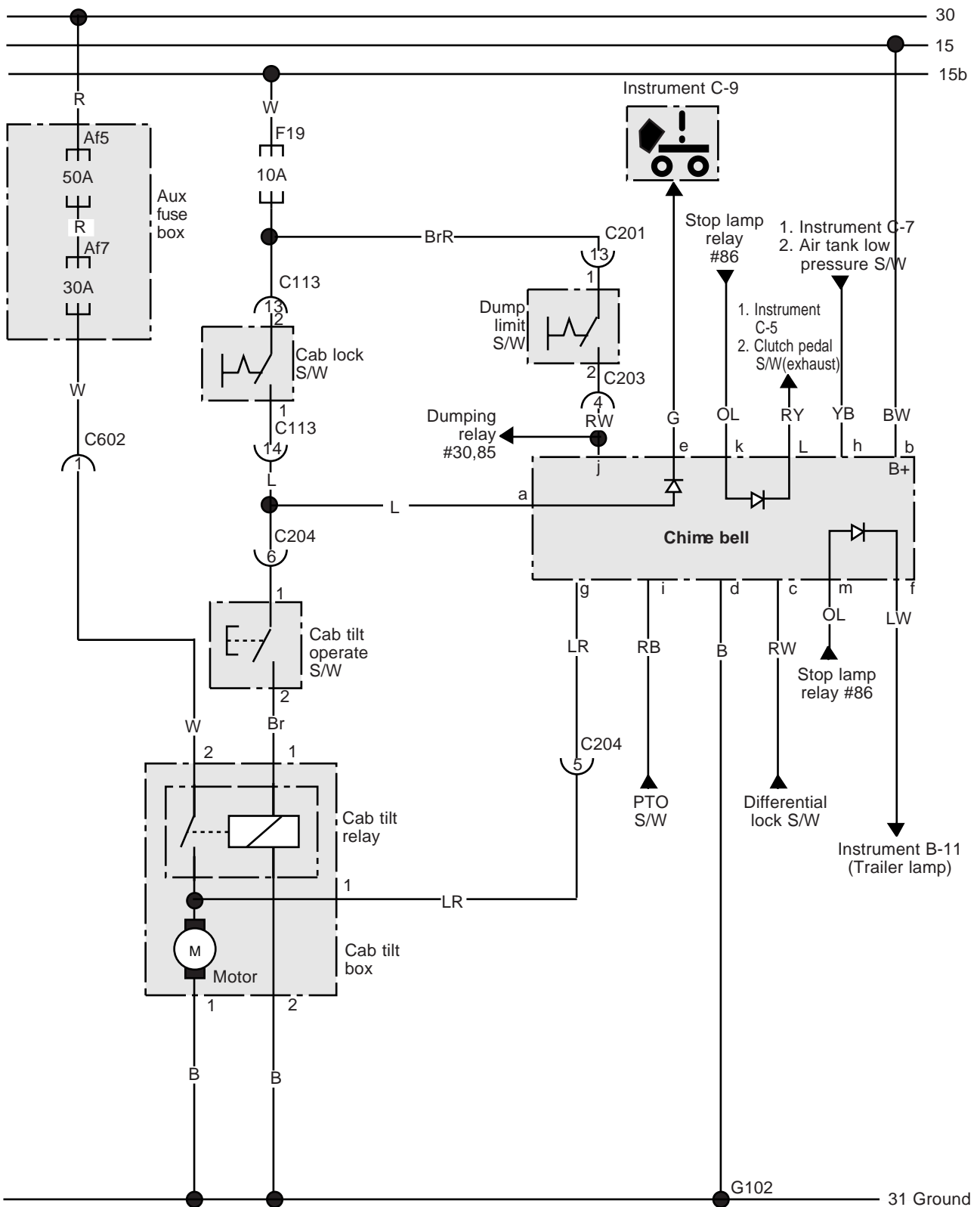

1) CONNECTOR AND PIN NUMBER

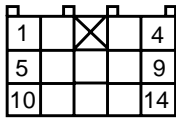

C113, 14pin

Dash - Roof harness
(Based on dash harness)

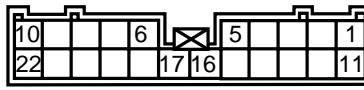

C201, 22pin

Dash - Frame harness
(Based on dash harness)

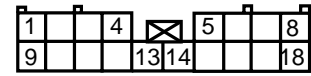

C203, 18pin

Dash - Frame harness
(Based on frame harness)

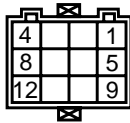

C204, 12pin

Dash - Frame harness
(Based on dash harness)



C602, 2pin

Aux fuse box - Frame harness
(Based on frame harness)

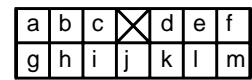

Chime bell connector
(Based on dash harness)



Cab lock S/W
(Based on roof harness)

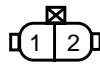

Cab tilt operate S/W
Dump limit S/W
(Based on frame harness)



Cab tilt motor



Chime bell
Cab tilt box
(Based on frame harness)

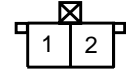

Cab tilt PBS SW

2) LOCATION OF PARTS

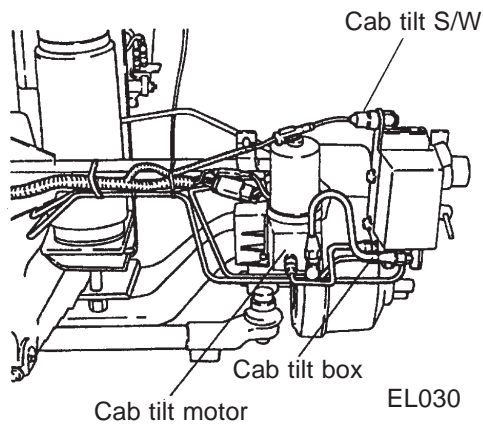

Cab tilt box

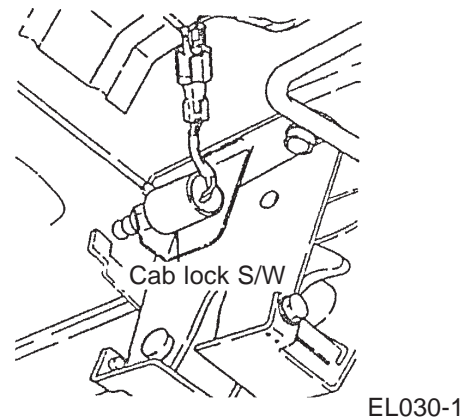

Cab lock S/W-Near the rear cab

8. CAB TILT (HYDRAULIC TYPE), CHIME BELL CIRCUIT DIAGRAM

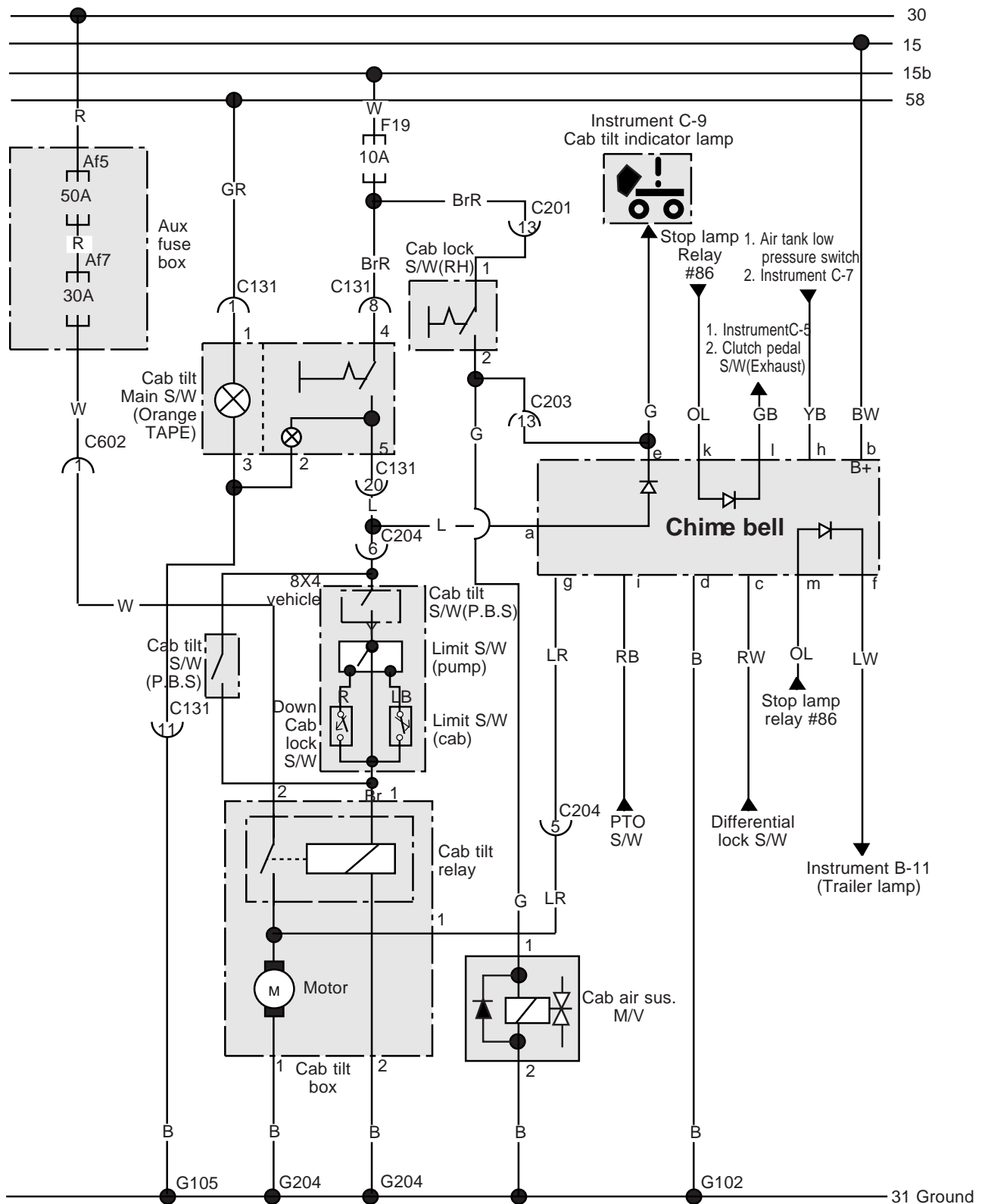

1) CONNECTOR AND PIN NUMBER

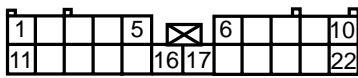

C131, 22pin

Dash - Roof harness
(Based on dash harness)

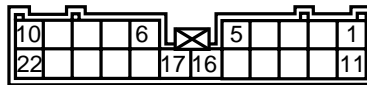

C201, 22pin

Dash - Frame harness
(Based on dash harness)

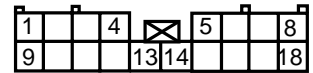

C203, 18pin

Dash - Frame harness
(Based on frame harness)

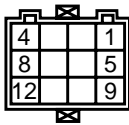

C204, 12pin

Dash - Frame harness
(Based on dash harness)



C602, 2pin

Aux fuse box - Frame harness
(Based on frame harness)

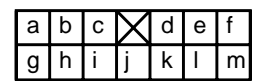

Chime bell connector
(Based on dash harness)

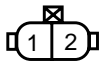

Cab air sus. M/V
(Based on frame harness)

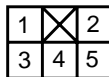

Cab tilt main S/W
(Based on dash harness)



Cab tilt motor



Chime bell

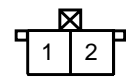

Cab tilt PBS SW

Cab tilt box
(Based on frame harness)

2) LOCATION OF PARTS

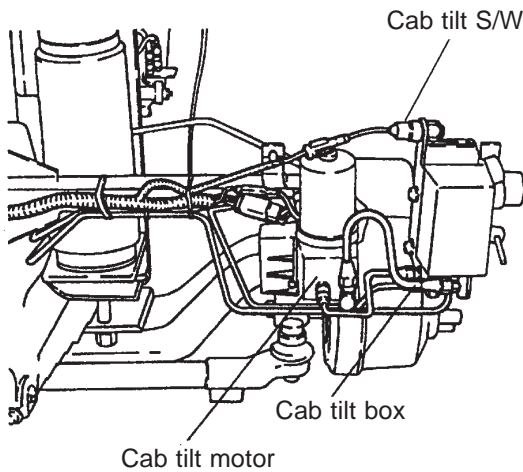

Cab tilt box

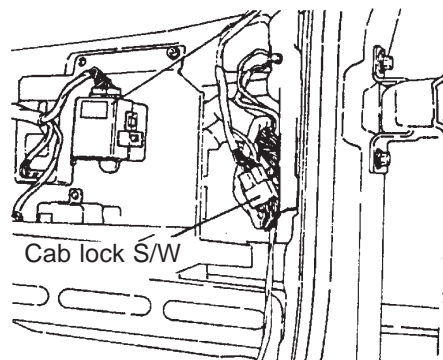

Cab lock s/w - near the rear cab

EL030

Ground

9. P.T.O, FOG LAMP CIRCUIT DIAGRAM

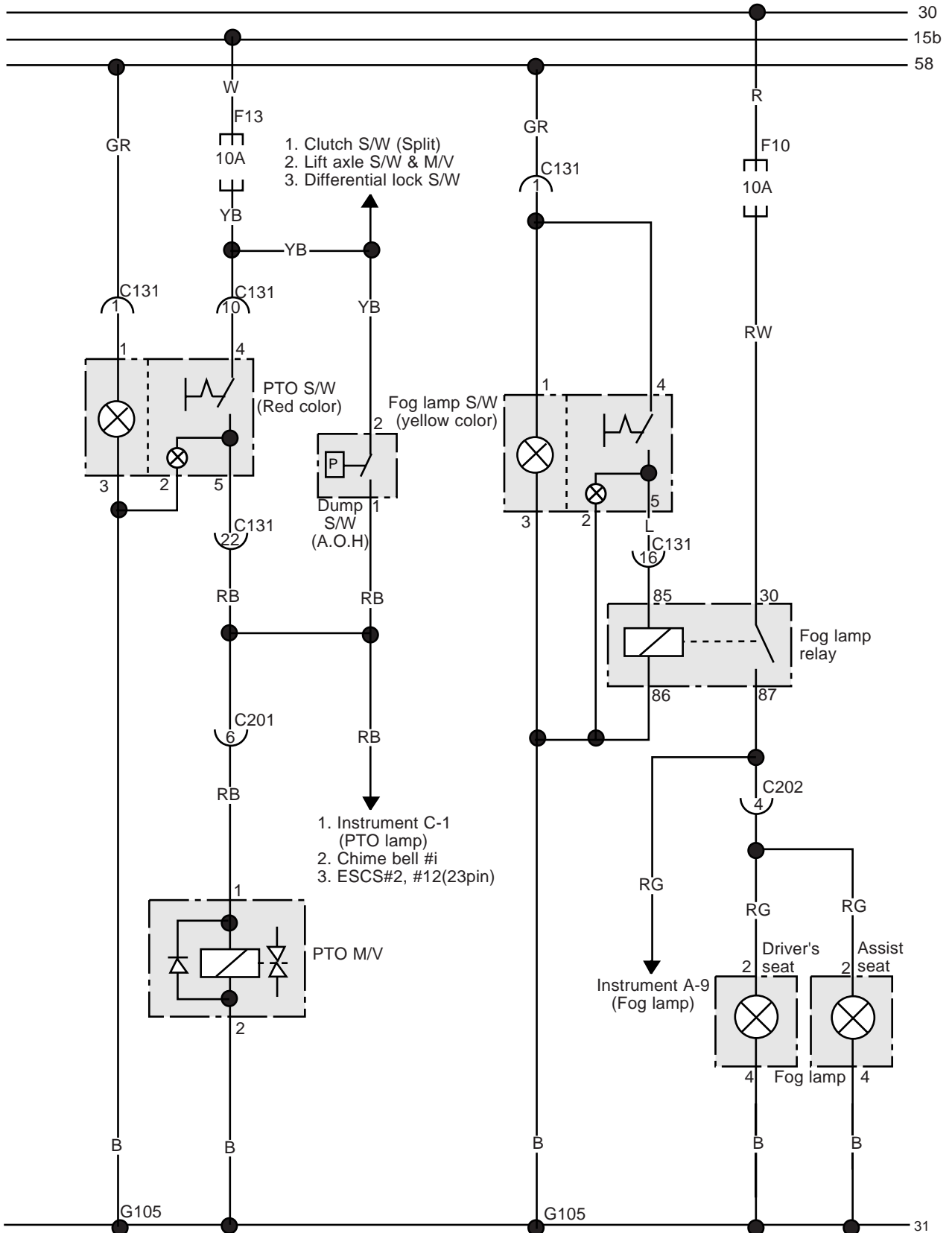

1) CONNECTOR AND PIN NUMBER

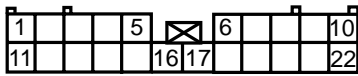

C131, 22pin

Dash - Switch harness
(Based on dash harness)

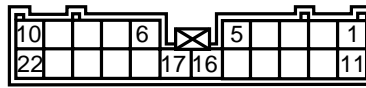

C201, 22pin

Dash - Frame harness
(Based on dash harness)

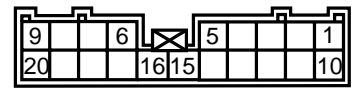

C202, 20pin

Dash - Frame harness
(Based on dash harness)

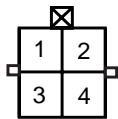

Head lamp
(Based on frame harness)

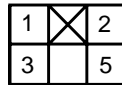

PTO/Fog lamp S/W
(Based on dash harness)

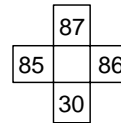

Fog lamp relay
(Fuse box)

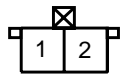

PTO M/V
(Based on frame harness)

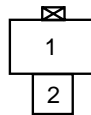

Dump control lever
(Based on dash harness)

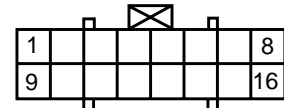

Instrument A
(Based on dash harness)

2) LOCATION OF PARTS

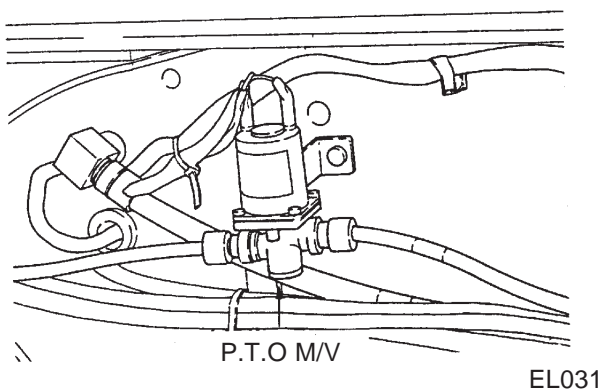

P.T.O M/V - Inside the Frame

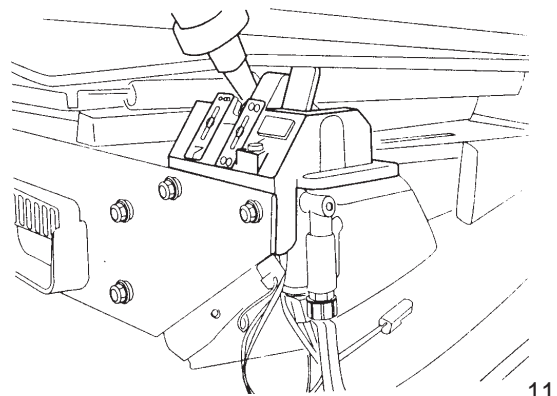

Dump control lever-Near the driver's seat

10. STOP LAMP, TRAILER STOP LAMP CIRCUIT DIAGRAM

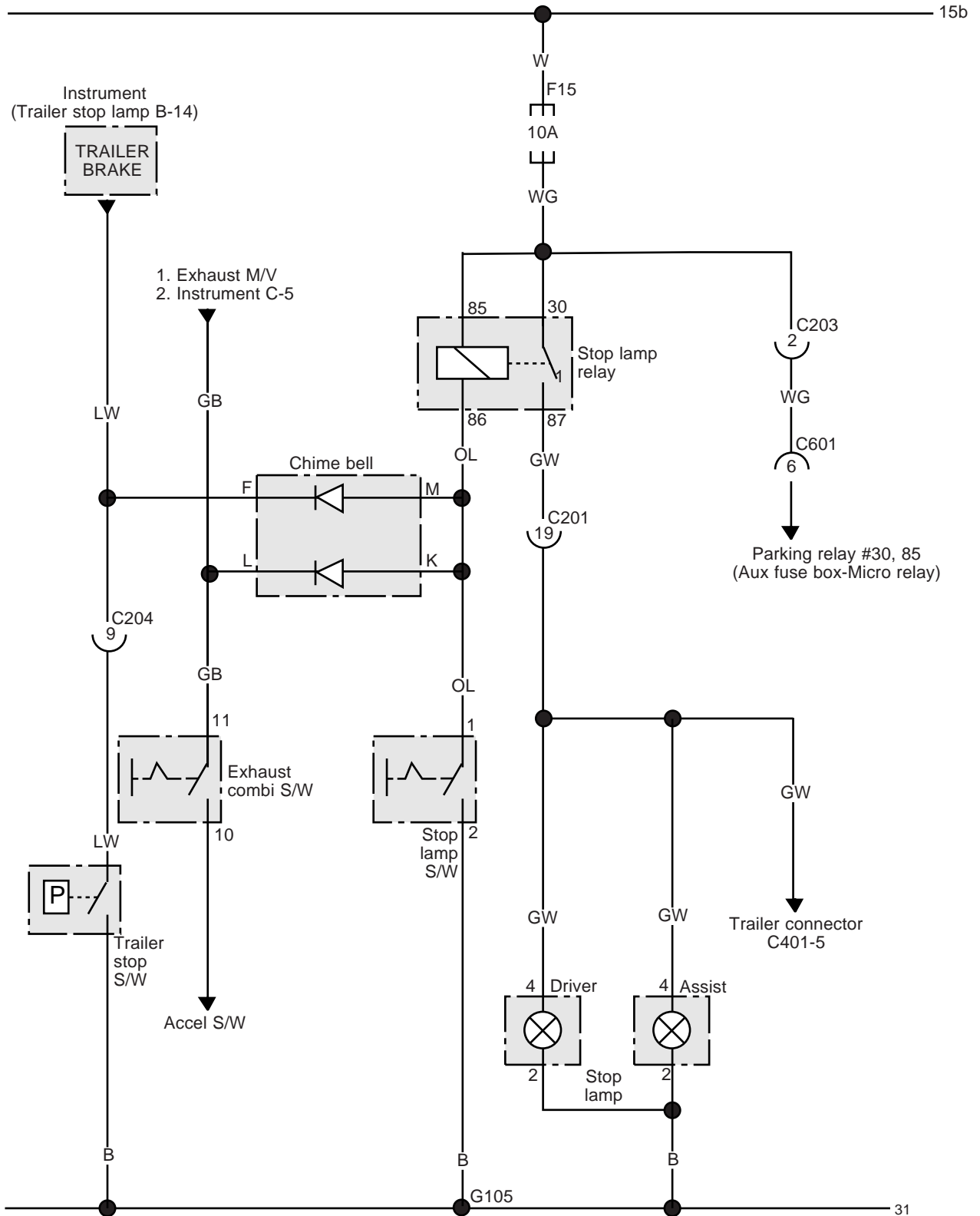

1) CONNECTOR AND PIN NUMBER

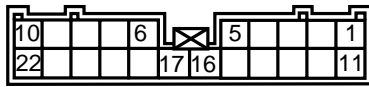

C201, 22pin

Dash - Frame harness
(Based on dash harness)

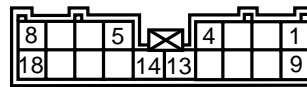

C203, 18pin

Dash - Frame harness
(Based on dash harness)

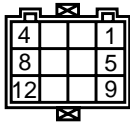

C204, 12pin

Dash - Frame harness
(Based on dash harness)

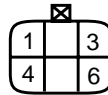

C401, 6pin

Frame - Trailer harness
(Based on frame harness)

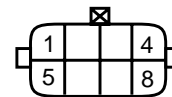

C601, 8pin

Frame - Aux fuse box harness
(Based on frame harness)

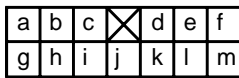

Chime bell unit
(Based on dash harness)

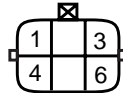

RR combi lamp(stop lamp)
(Based on frame harness)

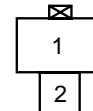

Stop lamp S/W
(Based on dash harness)

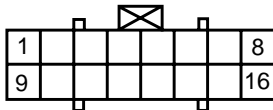

Instrument B
(Based on dash harness)

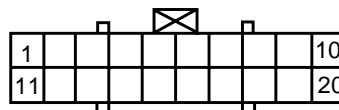

Instrument C
(Based on dash harness)

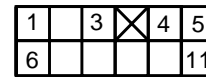

Exhaust combi S/W
(Based on dash harness)

2) LOCATION OF PARTS

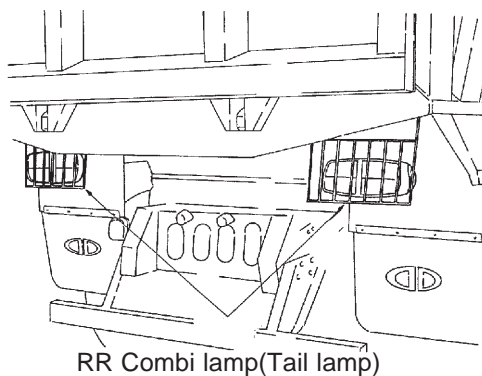

RR Combi lamp

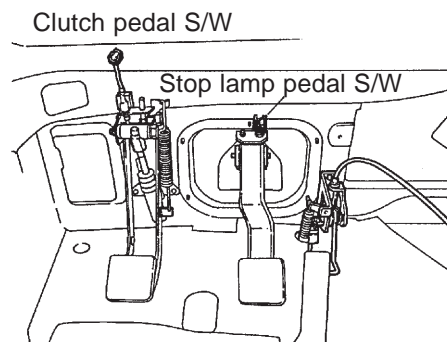

Stop lamp S/W - Upper brake pedal

EL032

11. CLEARANCE LAMP, LICENSE LAMP, ASHTRAY LAMP CIRCUIT DIAGRAM

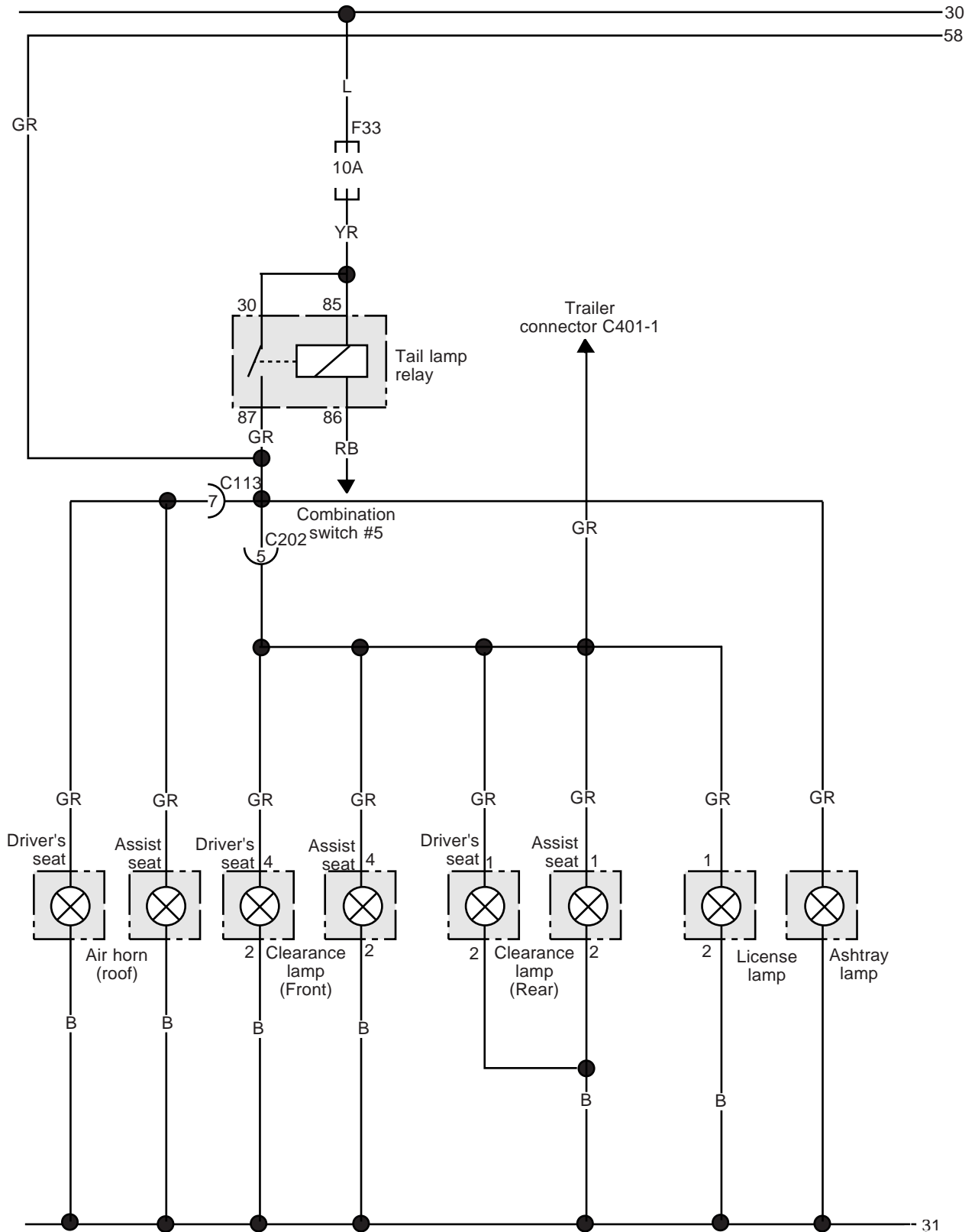

1) CONNECTOR AND PIN NUMBER

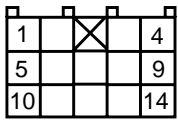

C113, 14pin

Dash - Roof harness
(Based on dash harness)

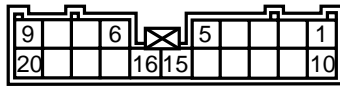

C202, 20pin

Dash - Frame harness
(Based on dash harness)

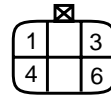

C401, 6pin

Frame - Trailer harness
(Based on frame harness)

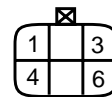

FRT/RR combi lamp
(Based on frame harness)

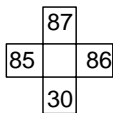

Tail lamp relay
(Fuse box)



Combination S/W
(Based on dash harness)



License lamp
(Based on frame harness)

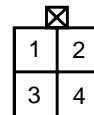

Air horn
(Based on roof harness)

2) LOCATION OF PARTS

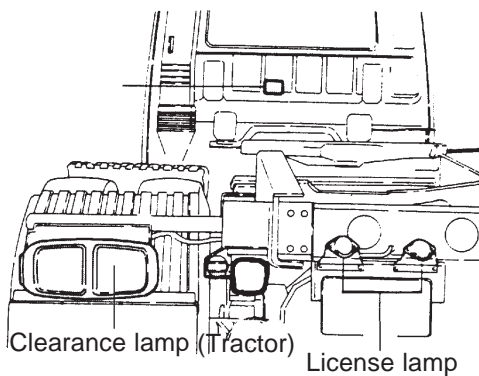
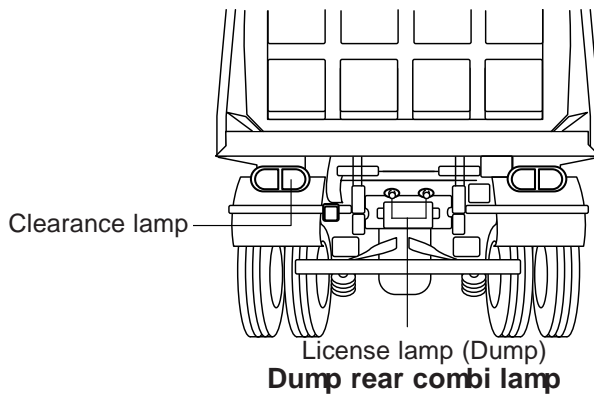

Tractor rear combi lamp

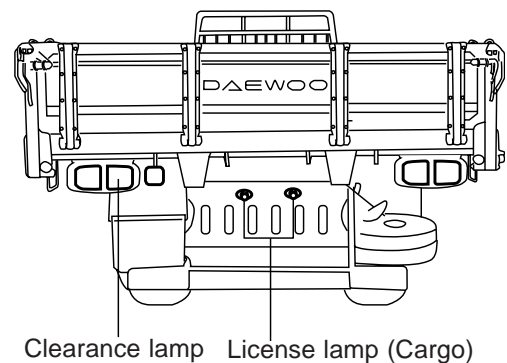

Cargo rear combi lamp

EL033

12. PARKING LAMP CIRCUIT DIAGRAM

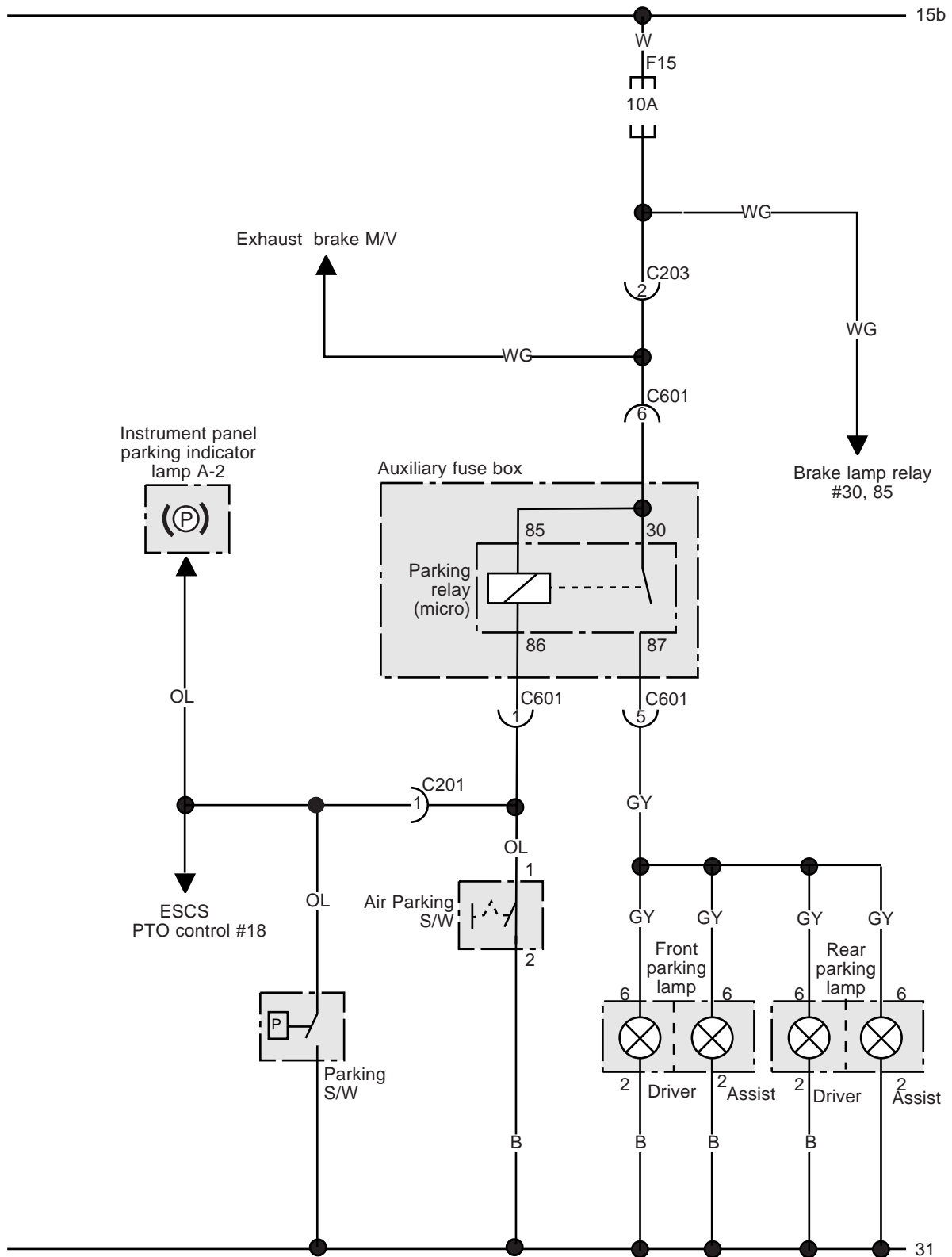

1) CONNECTOR AND PIN NUMBER

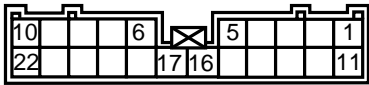

C201, 22pin

Dash - Frame harness
(Based on dash harness)

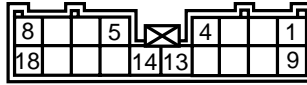

C203, 18pin

Dash - Frame harness
(Based on dash harness)

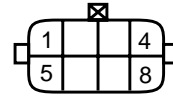

C601, 8pin

Frame - Aux fuse box harness
(Based on frame harness)

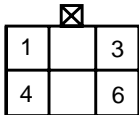

Combi lamp
(Based on frame harness)

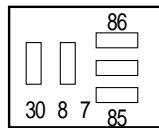

Parking lamp relay
(Aux. fuse box)

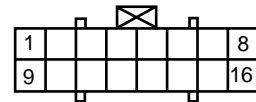

Instrument panel A
(Based on dash harness)

2) LOCATION OF PARTS

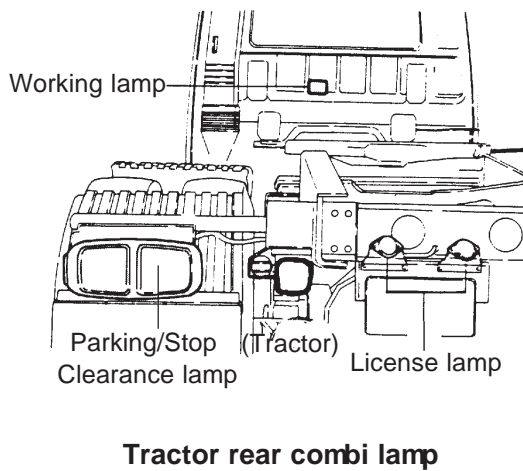
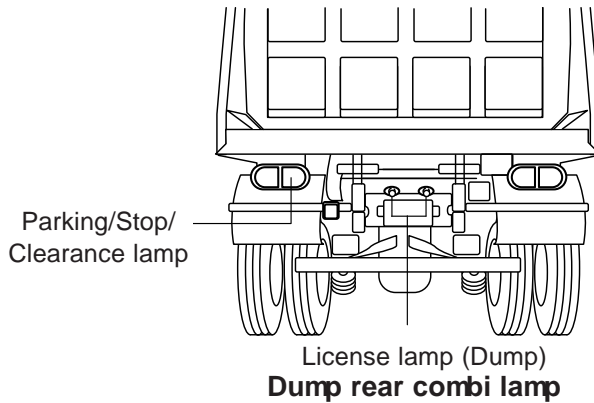

Tractor rear combi lamp

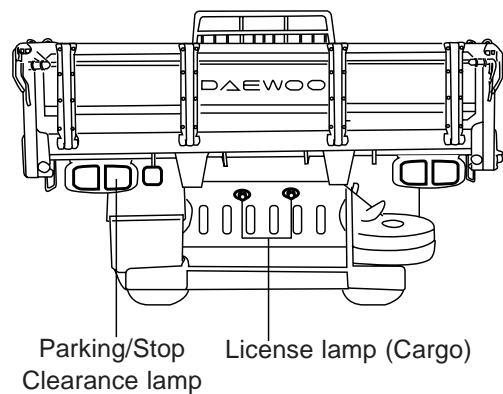

Cargo rear combi lamp

13. SEAT BELT TENSION REDUCER, STEP LAMP, LARGE ROOM LAMP, READING LAMP, MOOD LAMP, STOWAGE LAMP CIRCUIT DIAGRAM

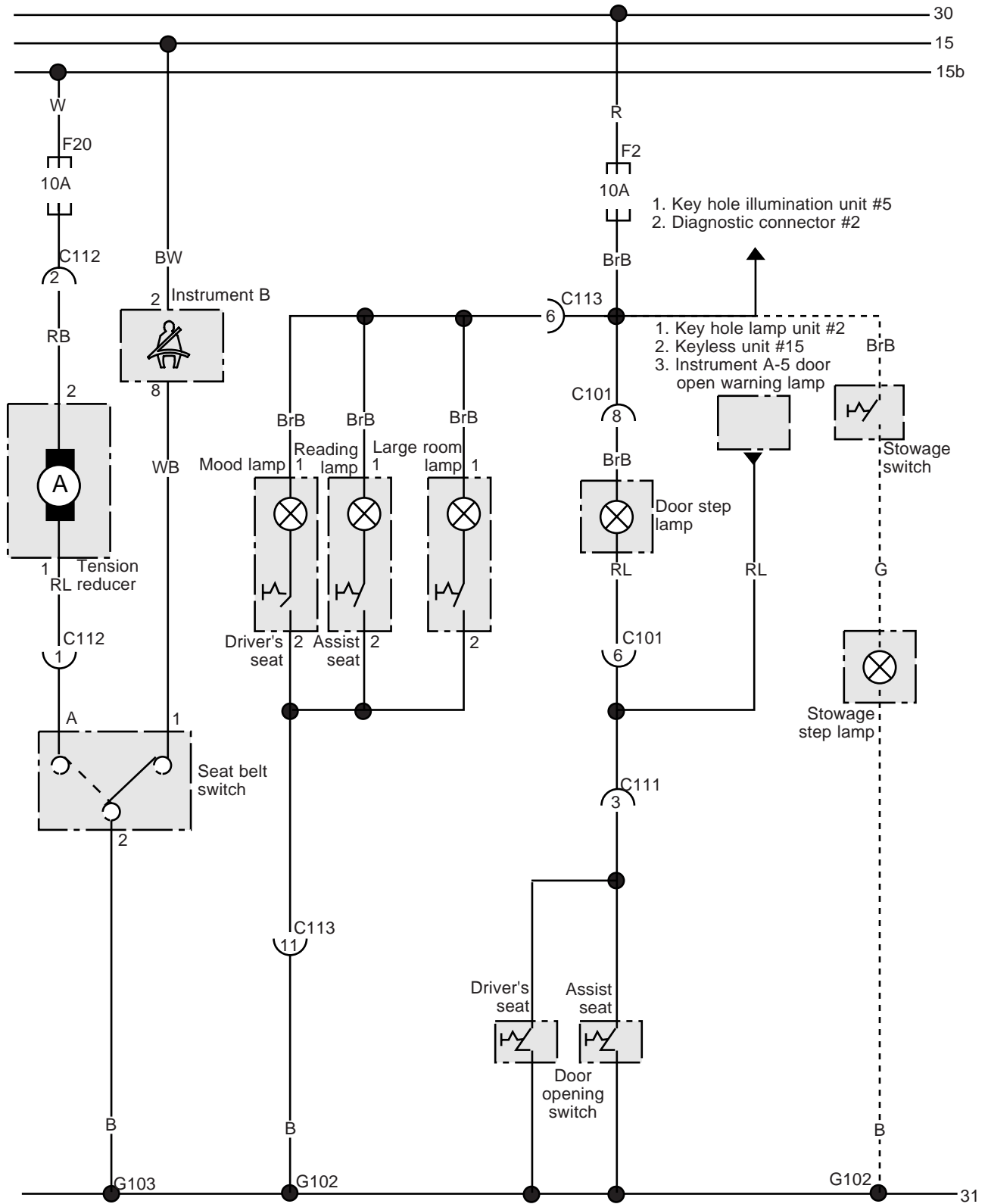

1) CONNECTOR AND PIN NUMBER

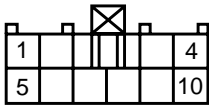

C101, 10pin

Dash - Door harness
(Based on dash harness)

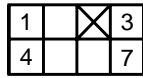

C111, 7pin

Dash - Roof harness
(Based on dash harness)



C112, 2pin

Dash - Roof harness
(Based on dash harness)

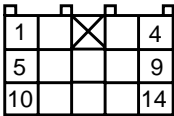

C113, 14pin

Dash - Roof harness
(Based on dash harness)

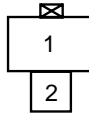

Tension reducer
(Based on roof harness)

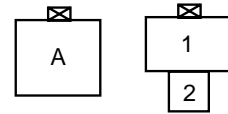

Set belt S/W
(based on dash harness)

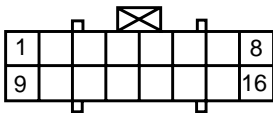

Instrument panel A
(Based on dash harness)



Large room lamp
(based on roof harness)



Mood/Reading lamp
(based on roof harness)

2) LOCATION OF PARTS

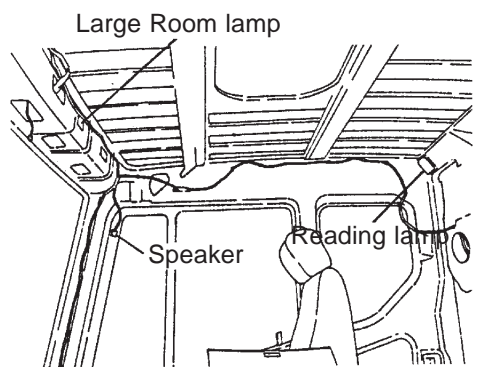

EL035

Large Room lamp / Reading lamp - Upper Cab

14. KEY HOLE ILLUMINATION LAMP, ROOM & SPOT LAMP CIRCUIT DIAGRAM

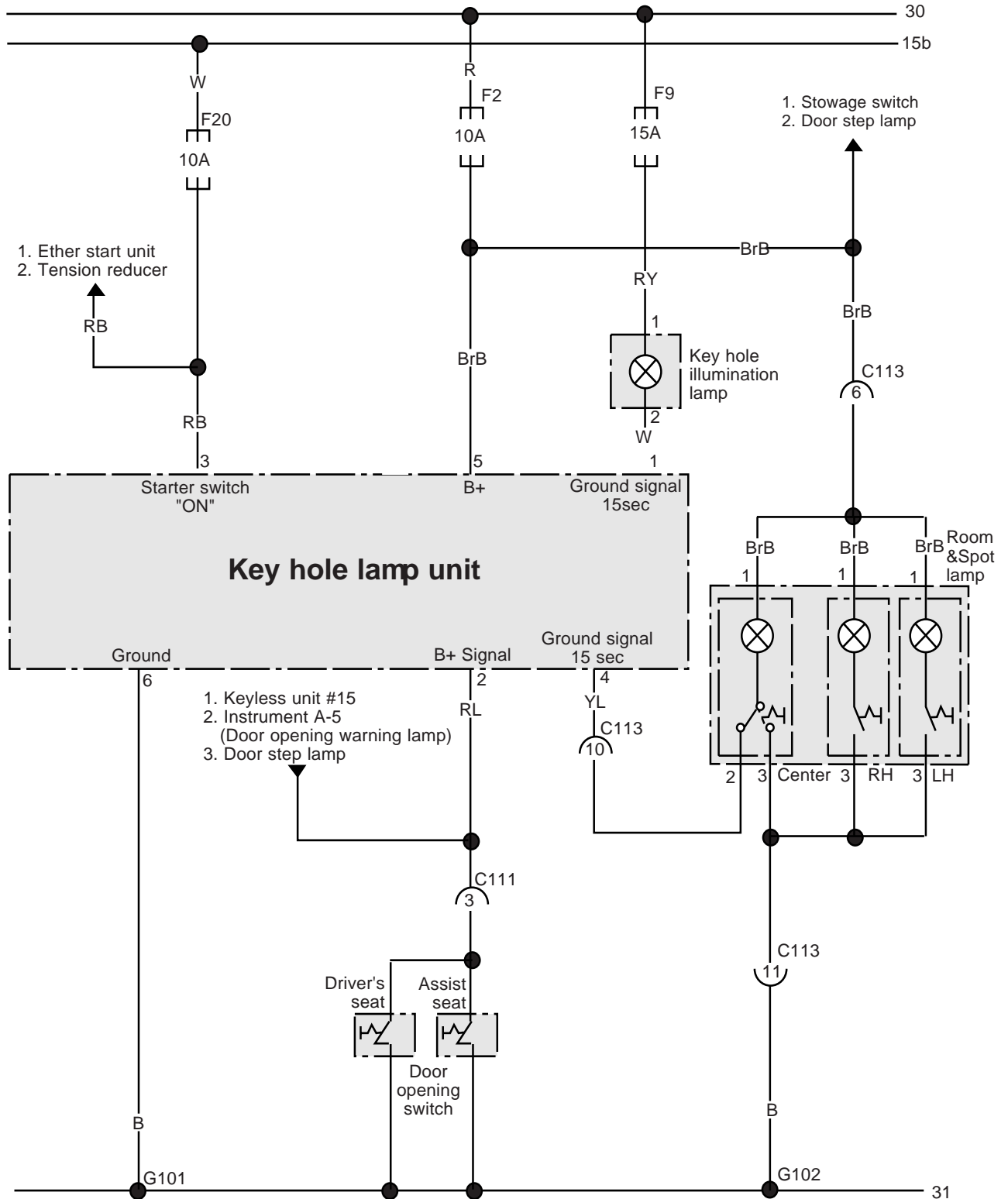

1) CONNECTOR AND PIN NUMBER

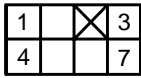

C111, 7pin

Dash - Roof harness
(Based on dash harness)

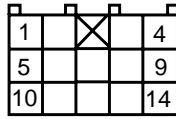

C113, 14pin

Dash - Roof harness
(Based on dash harness)

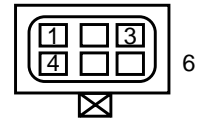

Key hole illumination lamp unit
(Fuse box)

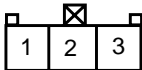

Room & spot lamp connector
(based on roof harness)



Key hole lamp
(Based on dash harness)

15. TURN SIGNAL LAMP, HAZARD WARNING LAMP CIRCUIT DIAGRAM

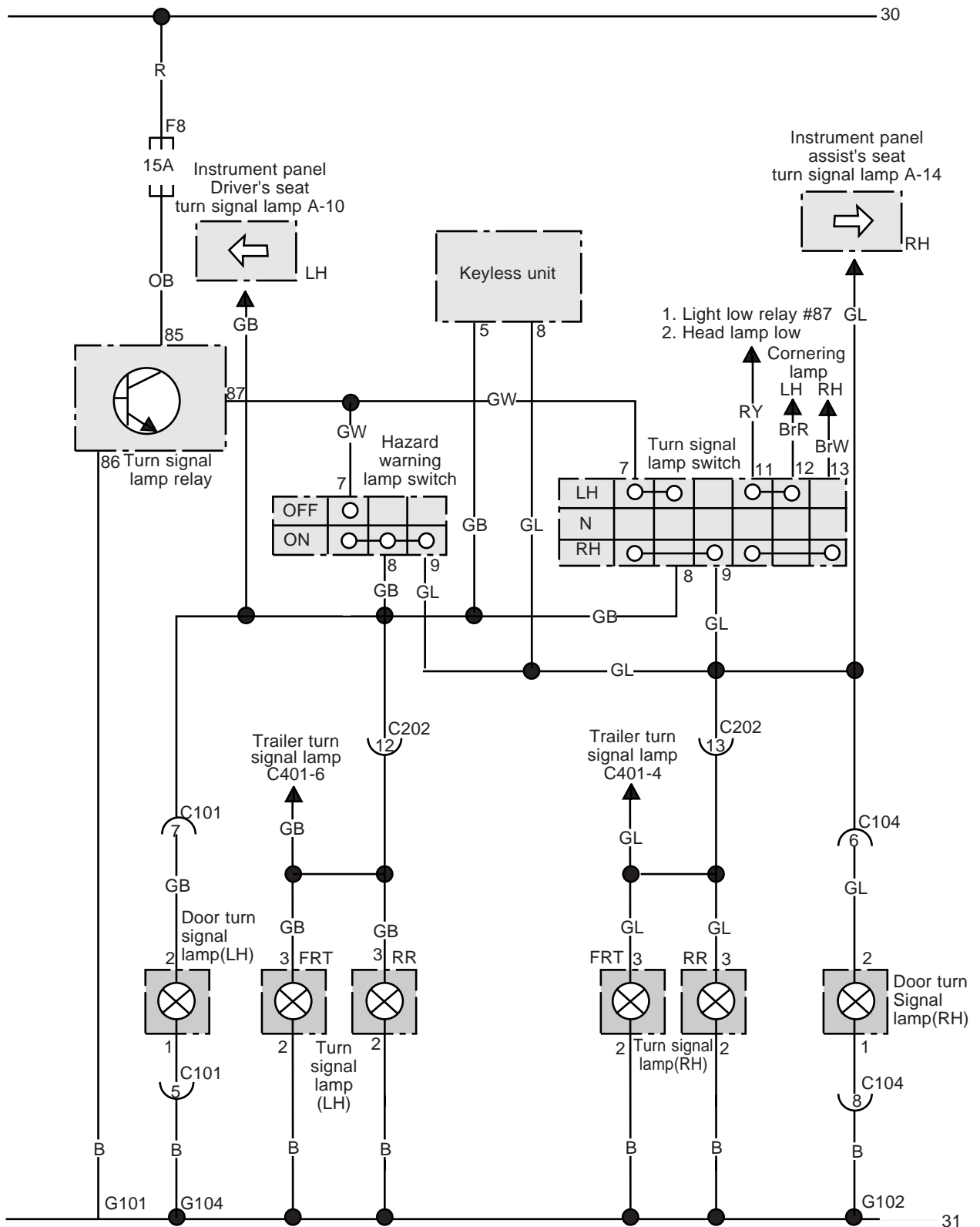

1) CONNECTOR AND PIN NUMBER

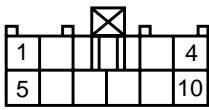

C101, 10pin

Dash - Driver's seat Door harness
(Based on dash harness)

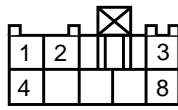

C104, 8pin

Dash - Assist seat Door harness
(Based on dash harness)

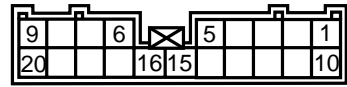

C202, 20pin

Dash - Frame harness
(Based on dash harness)

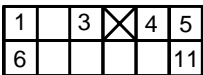

Wiper, hazard warning lamp

Combination S/W connector

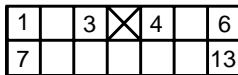

Light, turn signal lamp

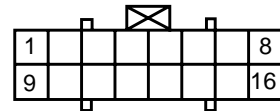

Instrument panel A
(Based on dash harness)

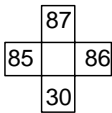

Turn signal lamp relay
(Fuse relay box)

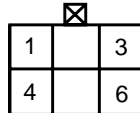

Combination (turn signal)connector
Trailer turn signal connector
(Based on frame harness)

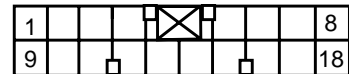

Keyless unit connector
(Based on dash harness)

2) LOCATION OF PARTS

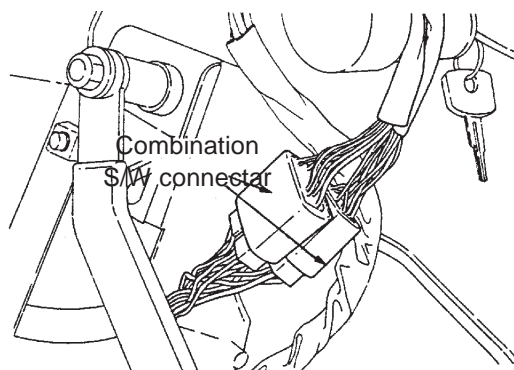

EL036

Combination S/W - Under the starter switch

16. CORNERING LAMP, AUTO GREASE CIRCUIT DIAGRAM

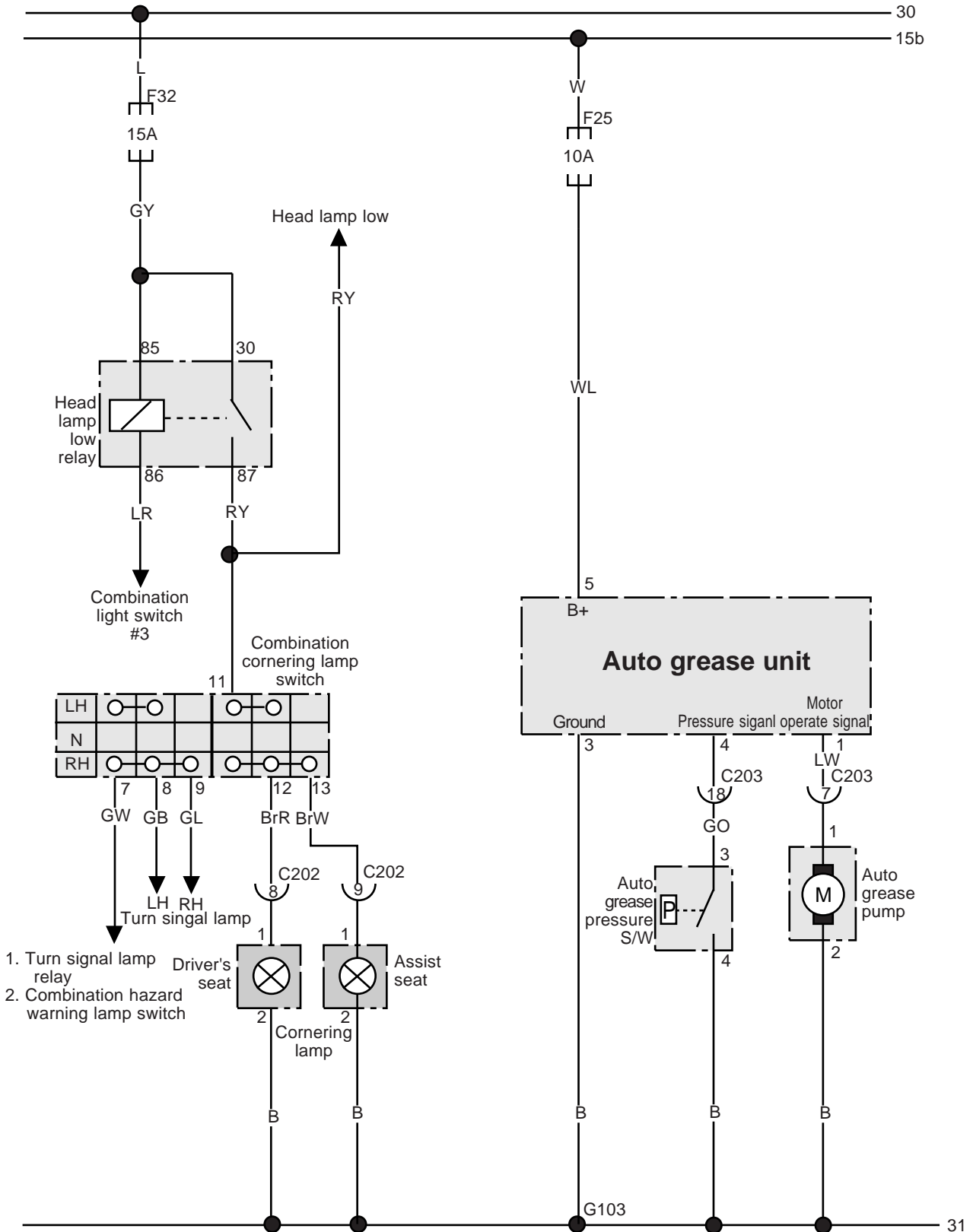

1) CONNECTOR AND PIN NUMBER

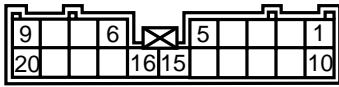

C202, 20pin

Dash - Frame harness
(Based on dash harness)

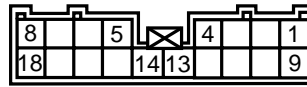

C203, 18pin

Dash - Frame harness
(Based on dash harness)

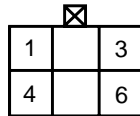

Auto grease unit
(Based on dash harness)

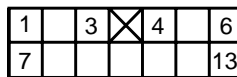

Cornering combination S/W
(Based on dash harness)



Auto grease S/W & pump connector
(Based on frame harness)

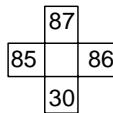

Head lamp low relay
(Fuse relay box)

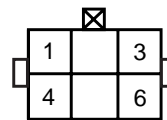

Combination cornering lamp
(based on frame harness)

17. CASSETTE, DIGITAL CLOCK CIRCUIT DIAGRAM

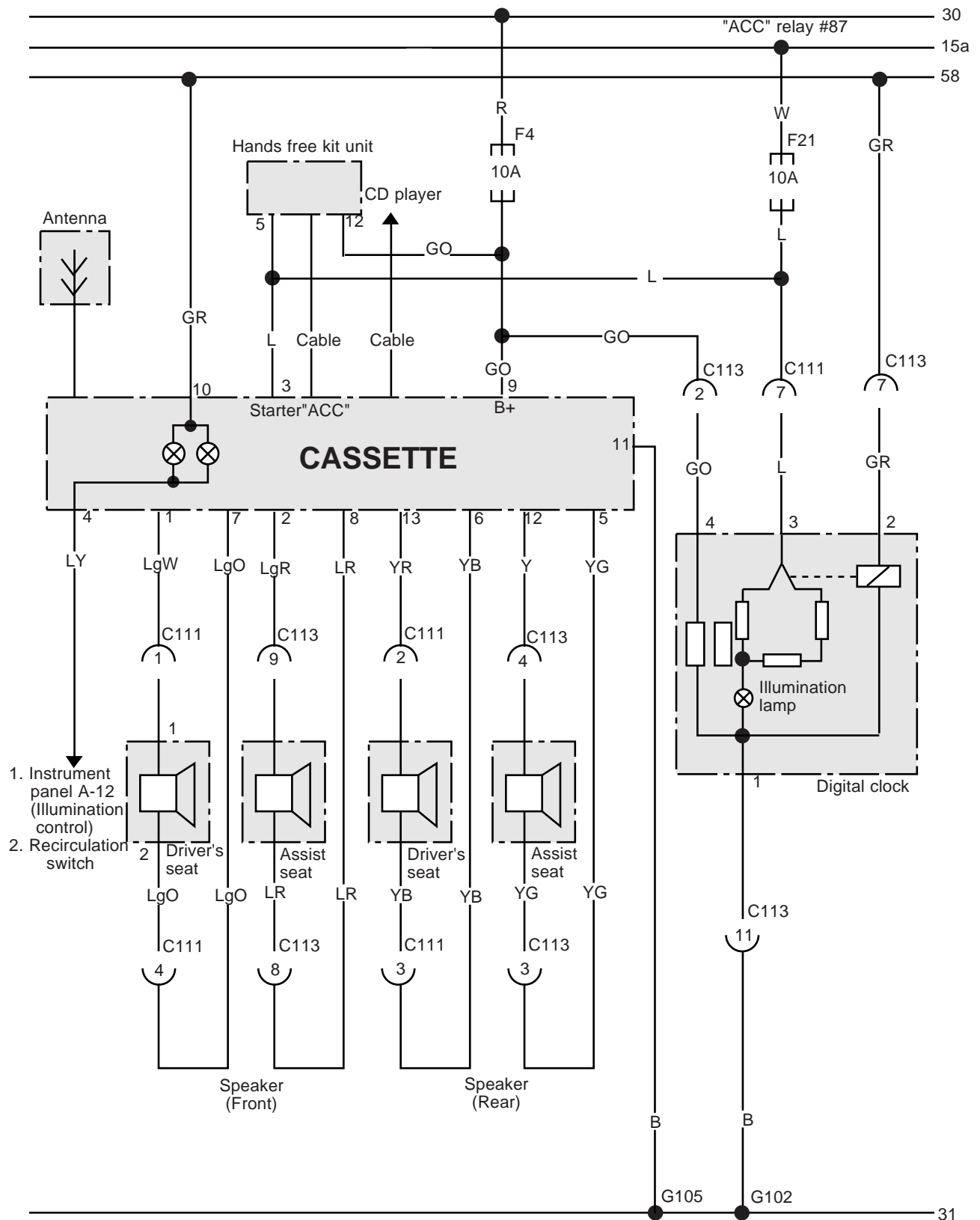

1. Instrument panel A-12 (Illumination control)
2. Recirculation switch

1) CONNECTOR AND PIN NUMBER

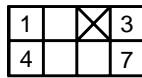

C111, 7pin

Dash - Roof harness
(Based on dash harness)

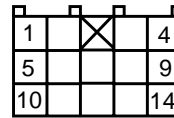

C113, 14pin

Dash - Roof harness
(Based on dash harness)

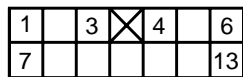

Cassette connector
(Based on dash harness)

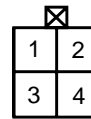

Digital clock connector
(Based on roof harness)

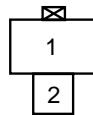

Speaker connector
(Based on roof harness)

18. DOOR LOCKING DEVICE, HORN CIRCUIT DIAGRAM

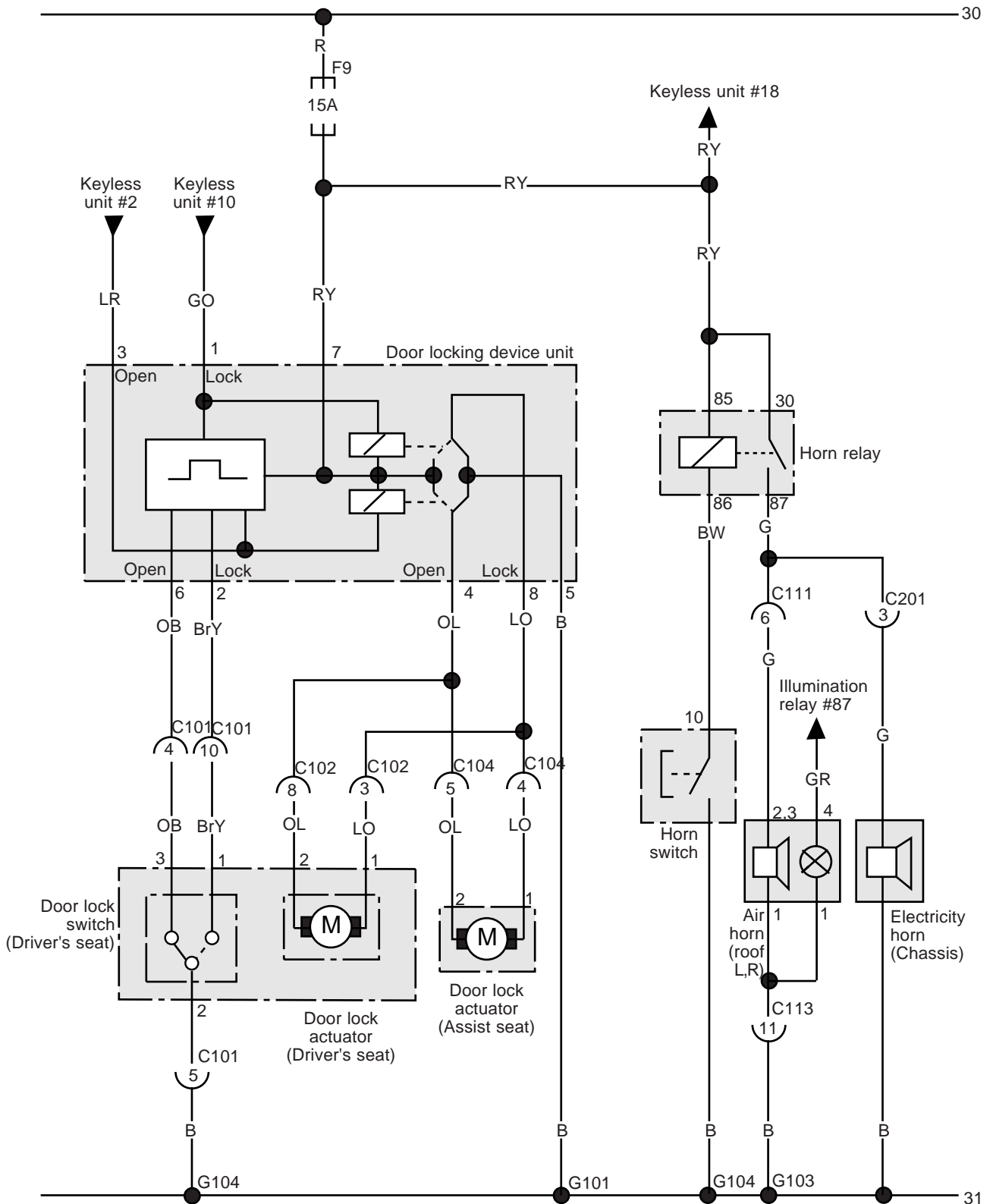

1) CONNECTOR AND PIN NUMBER

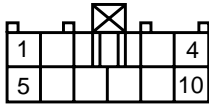

C101, 10pin

Dash - Driver's seat door harness
(Based on dash harness)

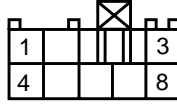

C102, 8pin

Dash - Driver's seat door harness
(Based on dash harness)

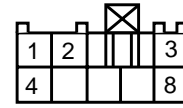

C104, 8pin

Dash - Assist seat Door harness
(Based on dash harness)

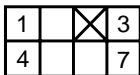

C111, 7pin

Dash - Roof harness
(Based on dash harness)

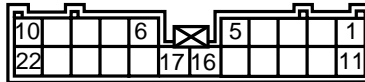

C201, 22pin

Dash - Frame harness
(Based on dash harness)

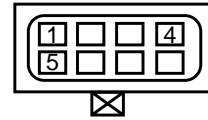

8

Door lock connector
(Fuse relay box)

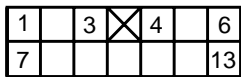

Combination horn S/W
(Based on dash harness)

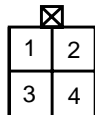

Air horn
(Based on roof harness)



Door lock switch
(Based on door harness)

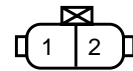

Door lock motor
(Based on door harness)

19. KEYLESS ENTRY SYSTEM

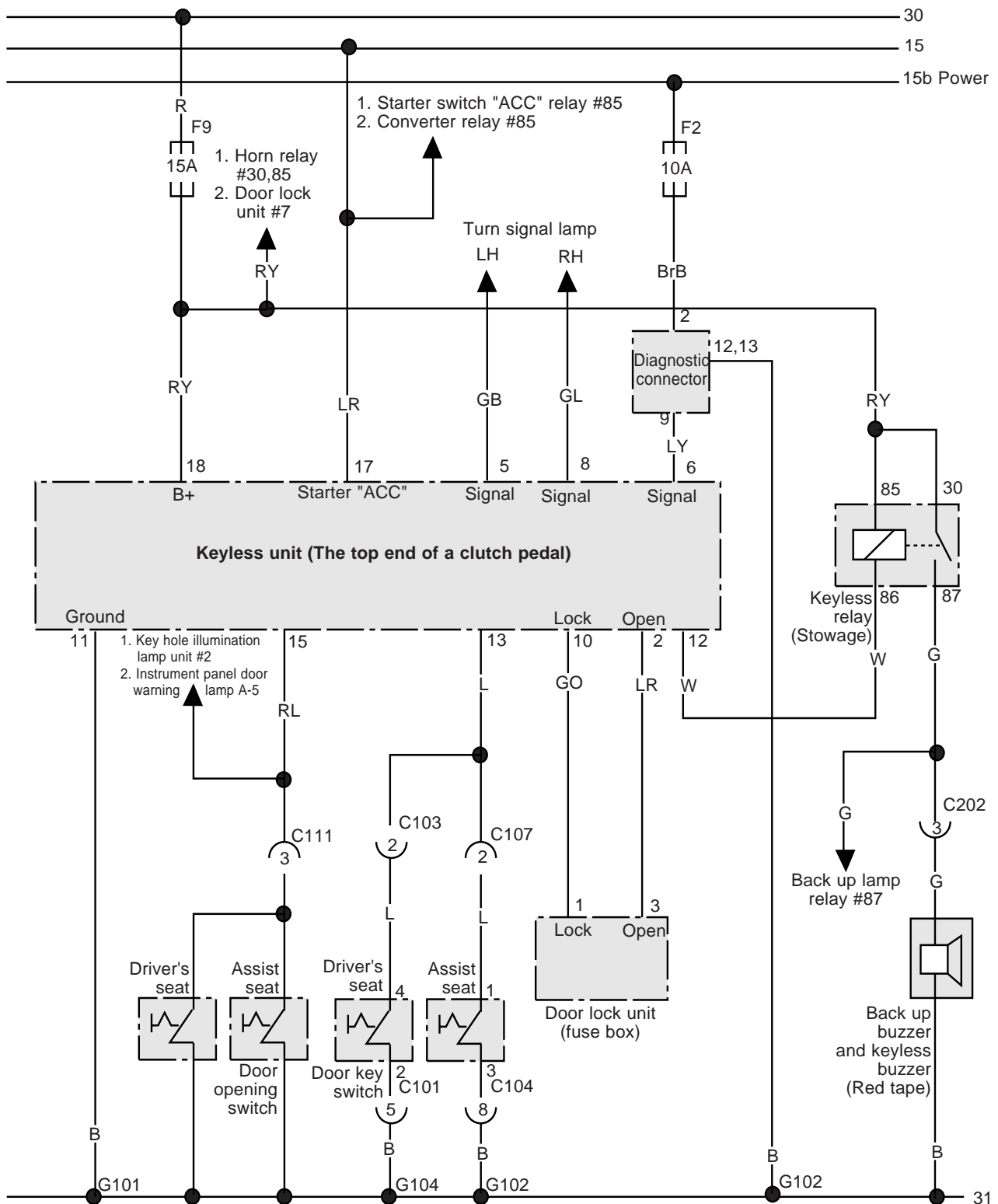

1) CONNECTOR AND PIN NUMBER

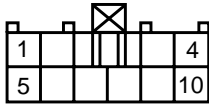

C101, 10pin

Dash - Door harness
(Based on dash harness)

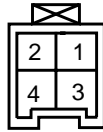

C103, 4pin

Dash - Door harness
(Based on dash harness)

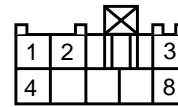

C104, 8pin

Dash - Door harness
(Based on dash harness)

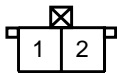

C107, 2pin

Dash - Door harness
(Based on dash harness)

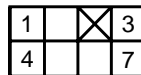

C111, 7pin

Dash - Roof harness
(Based on dash harness)

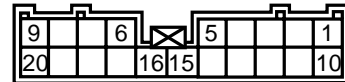

C202, 20pin

Dash - Frame harness
(Based on dash harness)

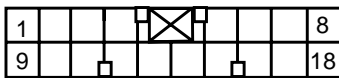

Keyless unit
(Based on dash harness)

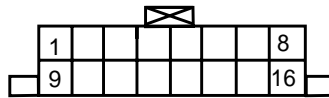

Diagnostic connector
(Based on dash harness)

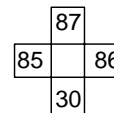

Keyless relay
(Based on dash harness)

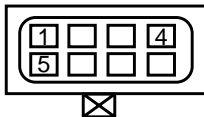

Door lock unit
(Fuse box)

8

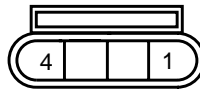

Door lock switch
(Based on door harness)

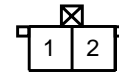

Keyless buzzer
(Based on frame harness)

20. EXHAUST BRAKE, DBR CIRCUIT DIAGRAM

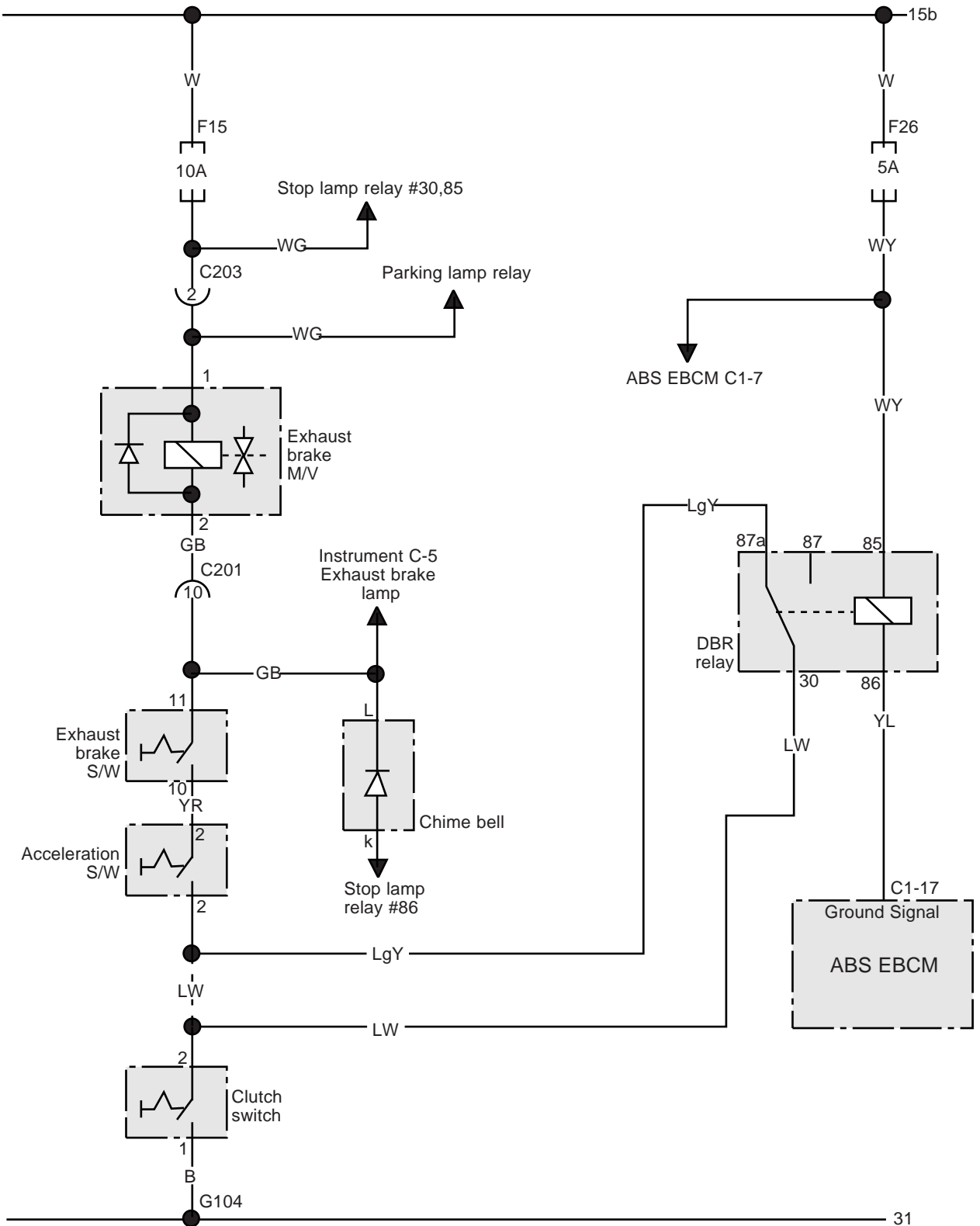

1) CONNECTOR AND PIN NUMBER

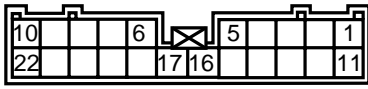

C201, 22pin

Dash - Frame harness
(Based on dash harness)

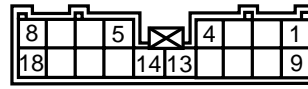

C203, 18pin

Dash - Frame harness
(Based on dash harness)

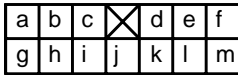

Chime bell unit
(Based on dash harness)

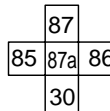

DBR relay
(Fuse relay box)

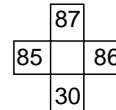

Stop lamp relay
(Fuse relay box)

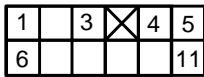

Exhaust combination S/W
(Based on dash harness)



Exhaust brake M/V
(Based on frame harness)

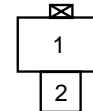

Acceleration S/W
Clutch S/W
(Based on dash harness)

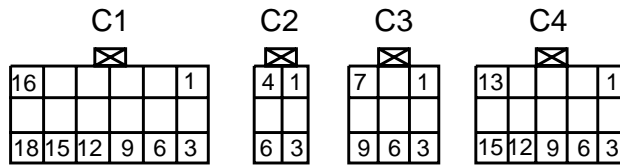

ABS/ASR ECM Connector

21. SPLIT SYSTEM (ZF, T14 TRANSMISSION)

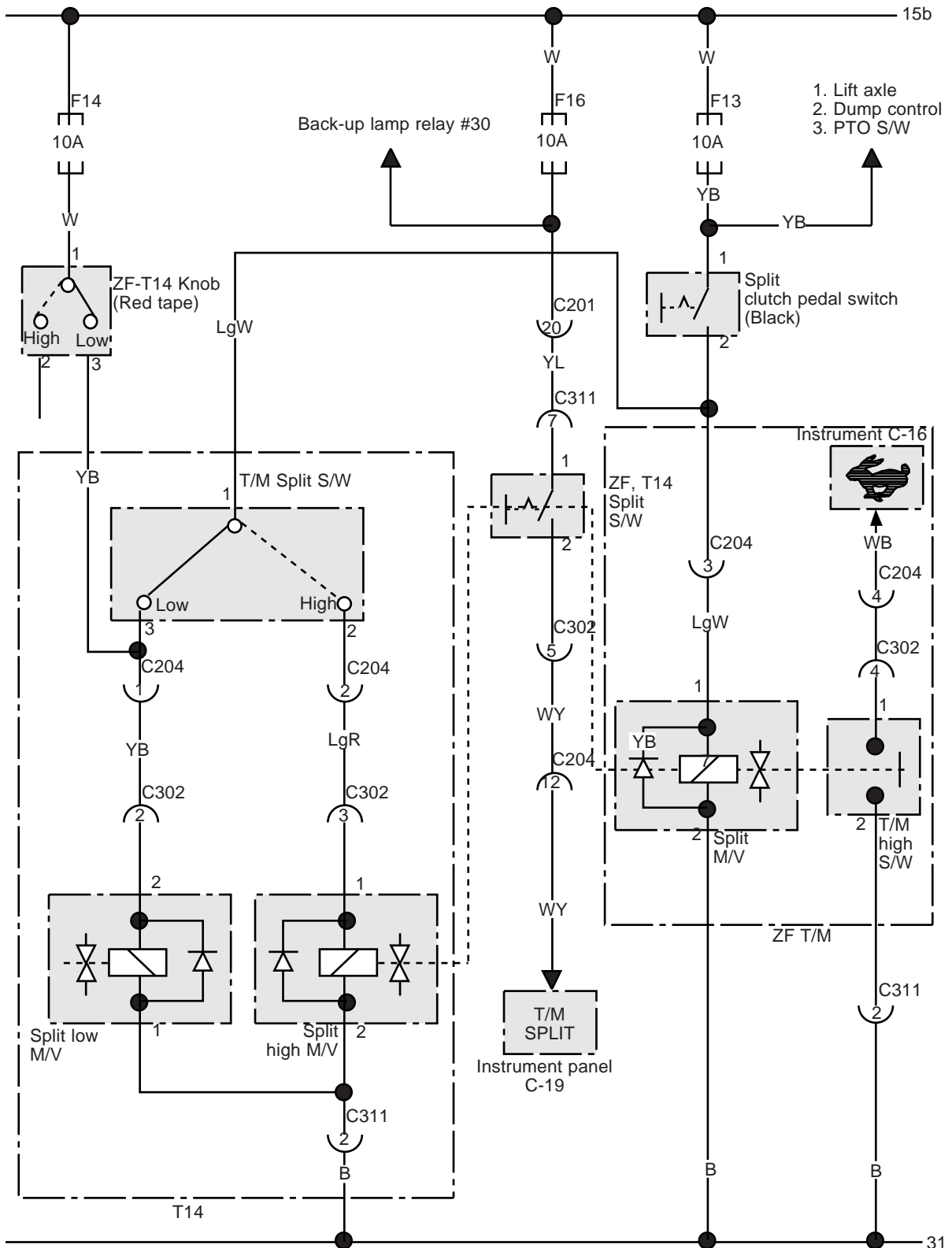

1) CONNECTOR AND PIN NUMBER

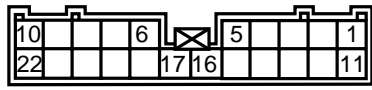

C201, 22pin

Dash - Frame harness
(Based on dash harness)

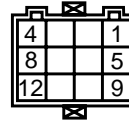

C204, 12pin

Dash - Frame harness
(Based on dash harness)

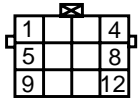

C311, 12pin

Frame - Engine harness
(Based on frame harness)

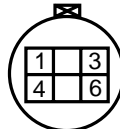

C302, 6pin

Frame - Engine harness
(Based on frame harness)

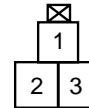

ZF-T14 Knob connector
(Based on dash harness)

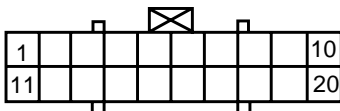

Instrument panel C
(Based on dash harness)



Split low M/V
(Based on engine harness)



Splitter high M/V
(Based on engine harness)



Split M/V
(Based on frame harness)

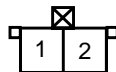

T14



ZF

T/M Splitter S/W
(Based on engine harness)

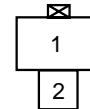

Splitter(Black) S/W
(Based on dash harness)

2) LOCATION OF PARTS

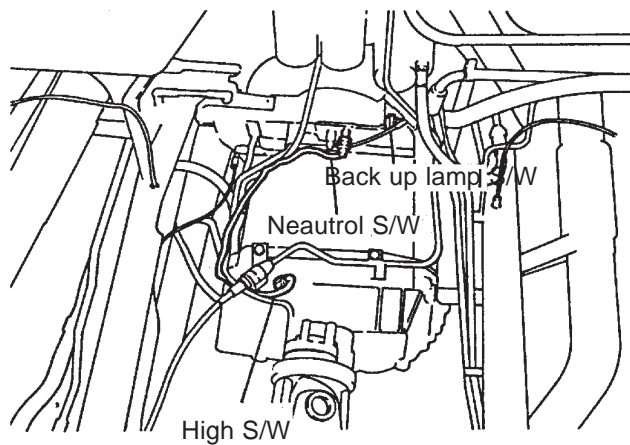

EL040

ZF transmission inside frame

22. POWER WINDOW CIRCUIT DIAGRAM

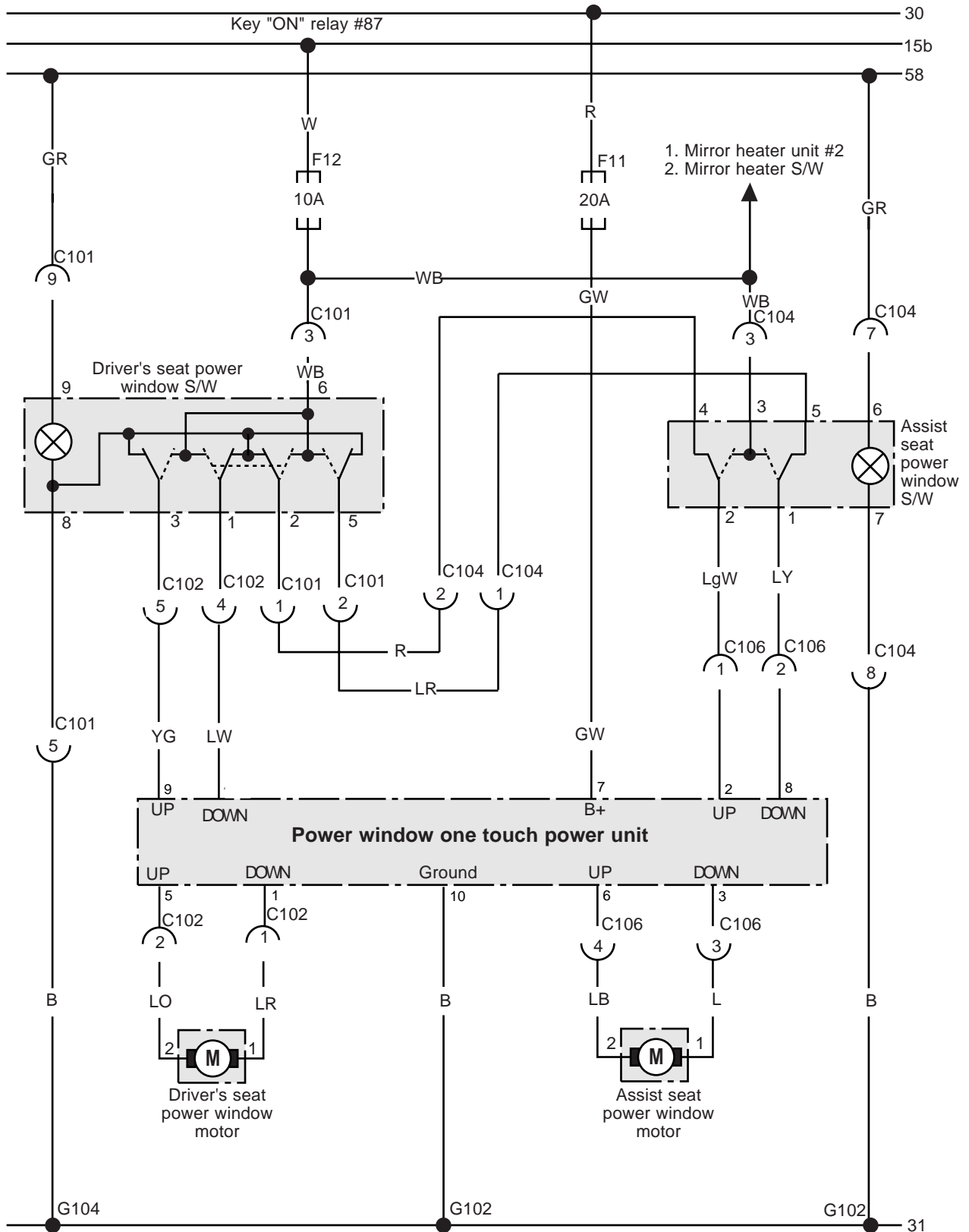

1) CONNECTOR AND PIN NUMBER

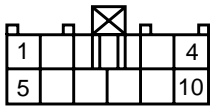

C101, 10pin

Dash - Driver's seat door harness
(Based on dash harness)

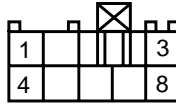

C102, 8pin

Dash - Driver's seat door harness
(Based on dash harness)

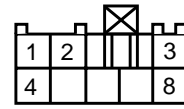

C104, 8pin

Dash - Assist seat Door harness
(Based on dash harness)

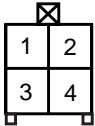

C106, 4pin

Dash - Assist seat Door harness
(Based on dash harness)

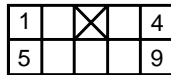

Driver's seat power window S/W connector
(Based on door harness)

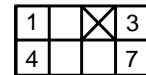

Assist seat power window S/W connector
(Based on door harness)



Power window motor
(Based on door harness)

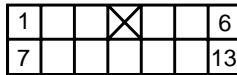

Power window one touch unit
(Based on dash harness)

2) LOCATION OF PARTS

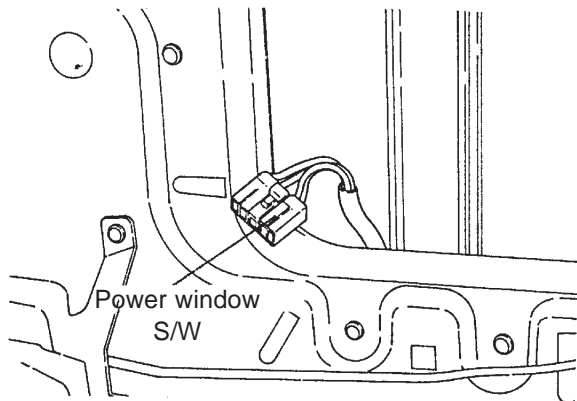

Power window S/W-Inside the door

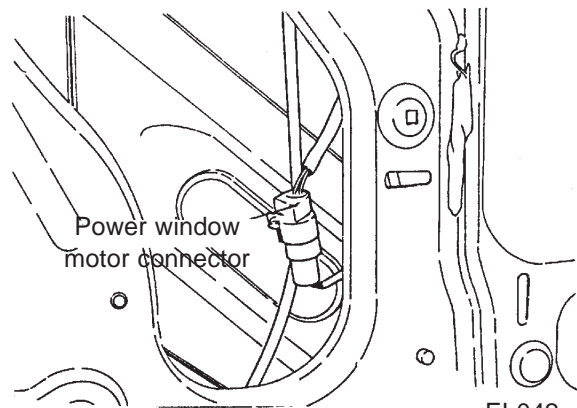

Power window motor - inside the door

EL042

23. WIPER CIRCUIT DIAGRAM

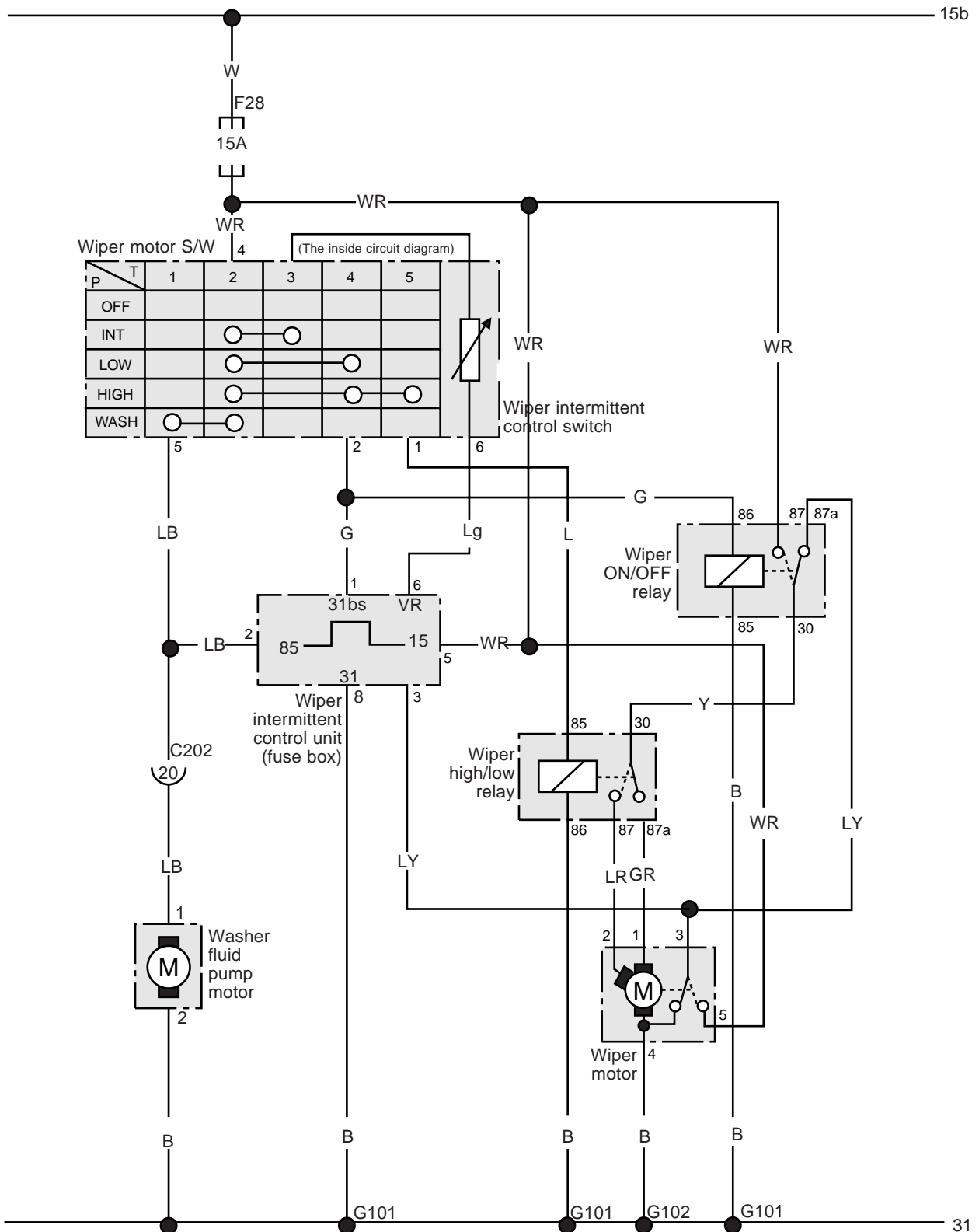

1) CONNECTOR AND PIN NUMBER

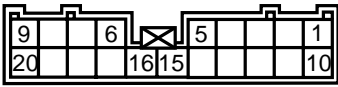

C202, 20pin

Dash - Frame harness
(Based on dash harness)

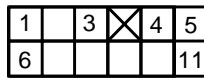

Wiper combination switch
(Based on dash harness)

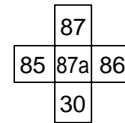

Wiper high/low relay
wiper ON/OFF relay
(fuse box)

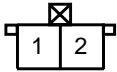

Washer fluid motor
(Based on frame harness)

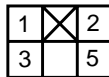

Wiper motor connector
(Based on dash harness)

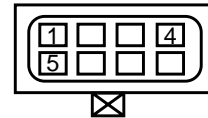

Wiper intermittent
control unit
(fuse box)

8

24. AUTO MIRROR AND MIRROR HEATER CIRCUIT DIAGRAM

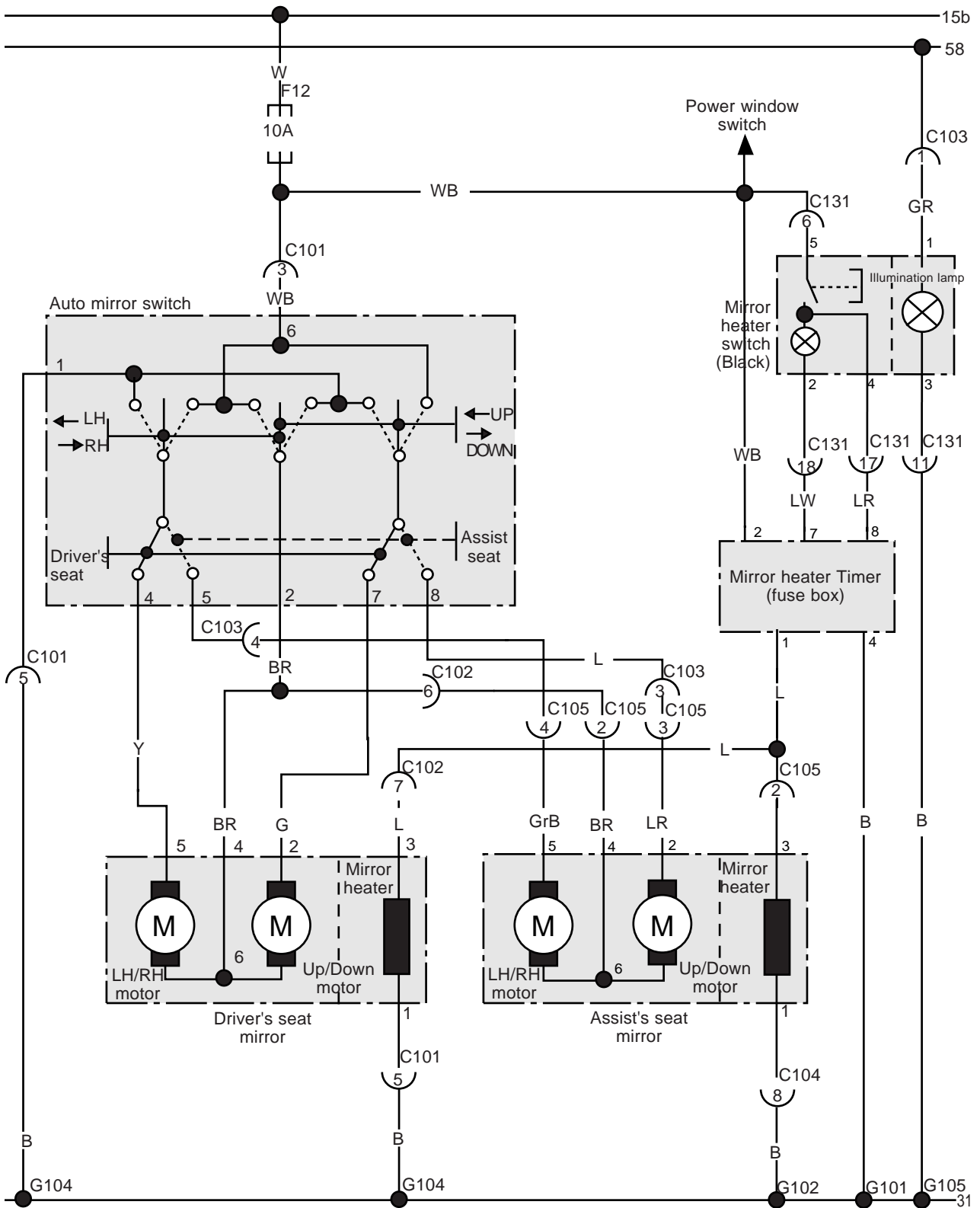

1) CONNECTOR AND PIN NUMBER

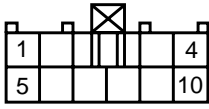

C101, 10pin

Dash - Door harness
(Based on dash harness)

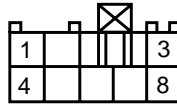

C102, 8pin

Dash - Door harness
(Based on dash harness)

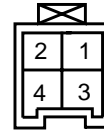

C103, 22pin

Dash - Door harness
(Based on dash harness)

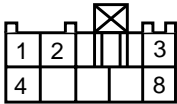

C104, 8pin

Dash - Door harness
(Based on dash harness)

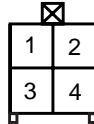

C105, 4pin

Dash - Door harness
(Based on door harness)

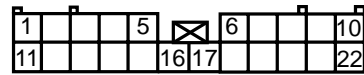

C131, 22pin

Dash - Switch harness
(Based on dash harness)

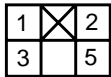

Mirror heater switch
(Based on dash harness)

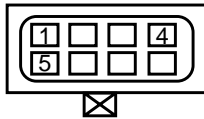

Mirror heater unit
(Fuse box)

8

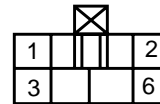

Mirror heater/Mirror motor
(Based on door harness)

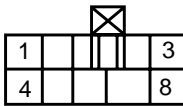

Auto mirror switch
(Based on door harness)

25. TACHOGRAPH CIRCUIT DIAGRAM (VDO, CASPO)

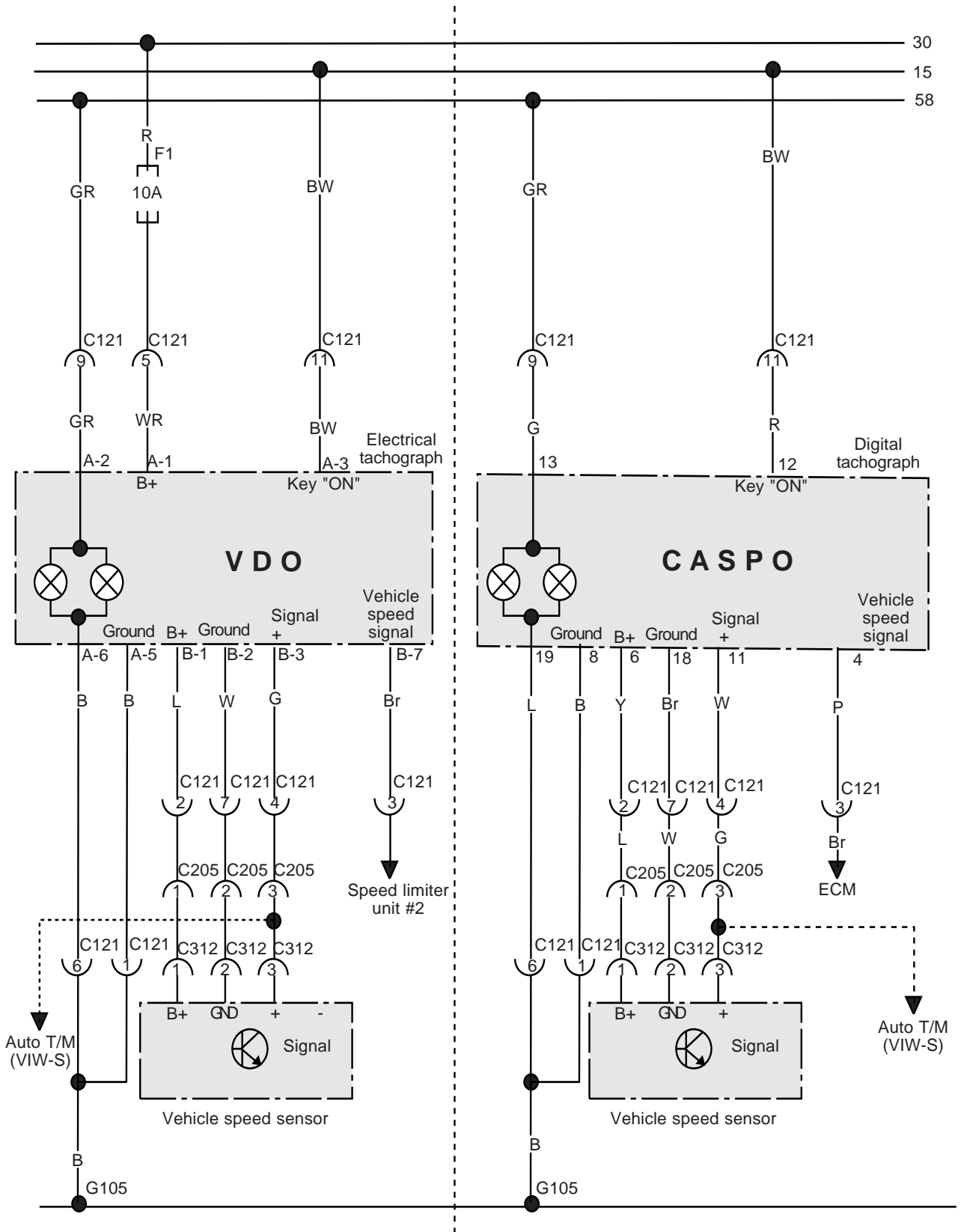

1) CONNECTOR AND PIN NUMBER

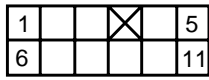

C121, 11pin

Dash - Tachograph harness
(Based on dash harness)

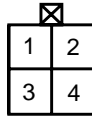

C205, 4pin

Dash - Frame harness
(Based on dash harness)

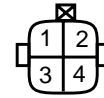

C312, 4pin

Frame - Engine harness
(Based on frame harness)

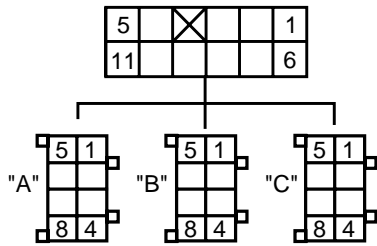

VDO electrical tachograph

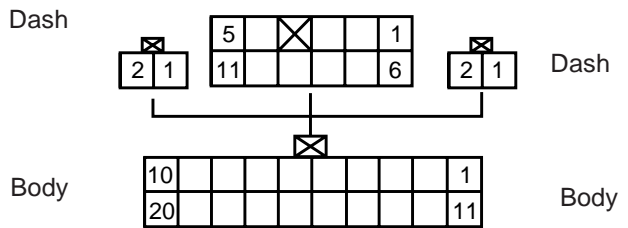

CASPO Digital Tachograph

26. HEATER AND AIR CONDITIONER CIRCUIT DIAGRAM

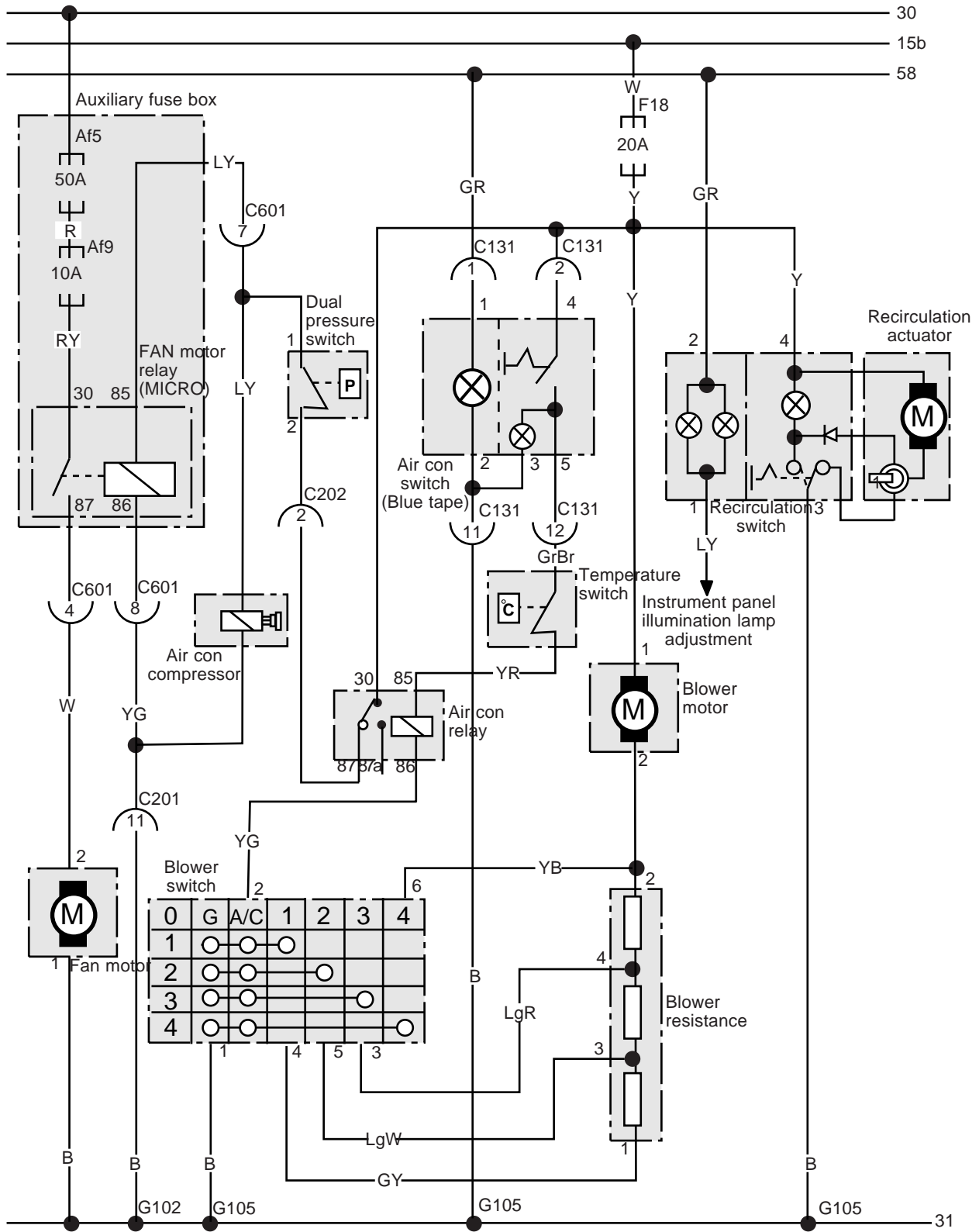

1) CONNECTOR AND PIN NUMBER

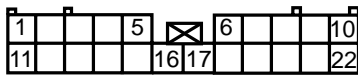

C131, 22pin

Dash - Switch harness
(Based on dash harness)

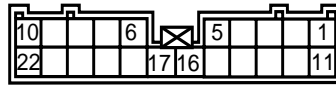

C201, 22pin

Dash - Frame harness
(Based on dash harness)

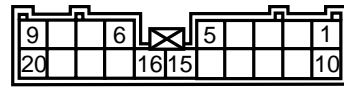

C202, 20pin

Dash - Frame harness
(Based on dash harness)

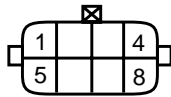

C601, 8pin

Frame - Aux fuse box harness
(Based on frame harness)

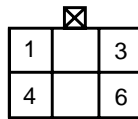

Blower switch
(Based on dash harness)

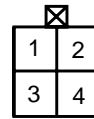

Blower resistance
(Based on dash harness)

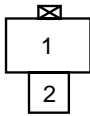

Blower motor
(Based on dash harness)

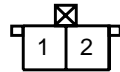

Fan motor
(Based on frame harness)



Dual pressure switch
(Based on frame harness)

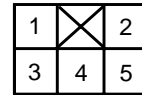

Aircon/recirculation switch
(Based on dash harness)

2) LOCATION OF PARTS

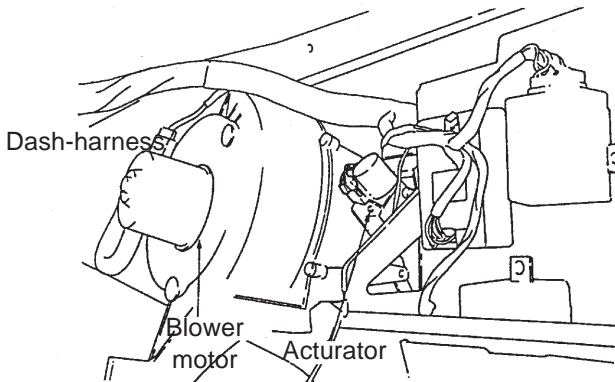

Blower motor - inside IP

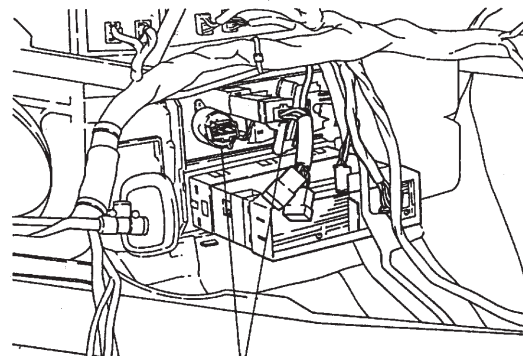

Aircon switch - inside IP

EL050

27. SPEED LIMITER CIRCUIT DIAGRAM(ELECTRICAL TACHOGRAPH)

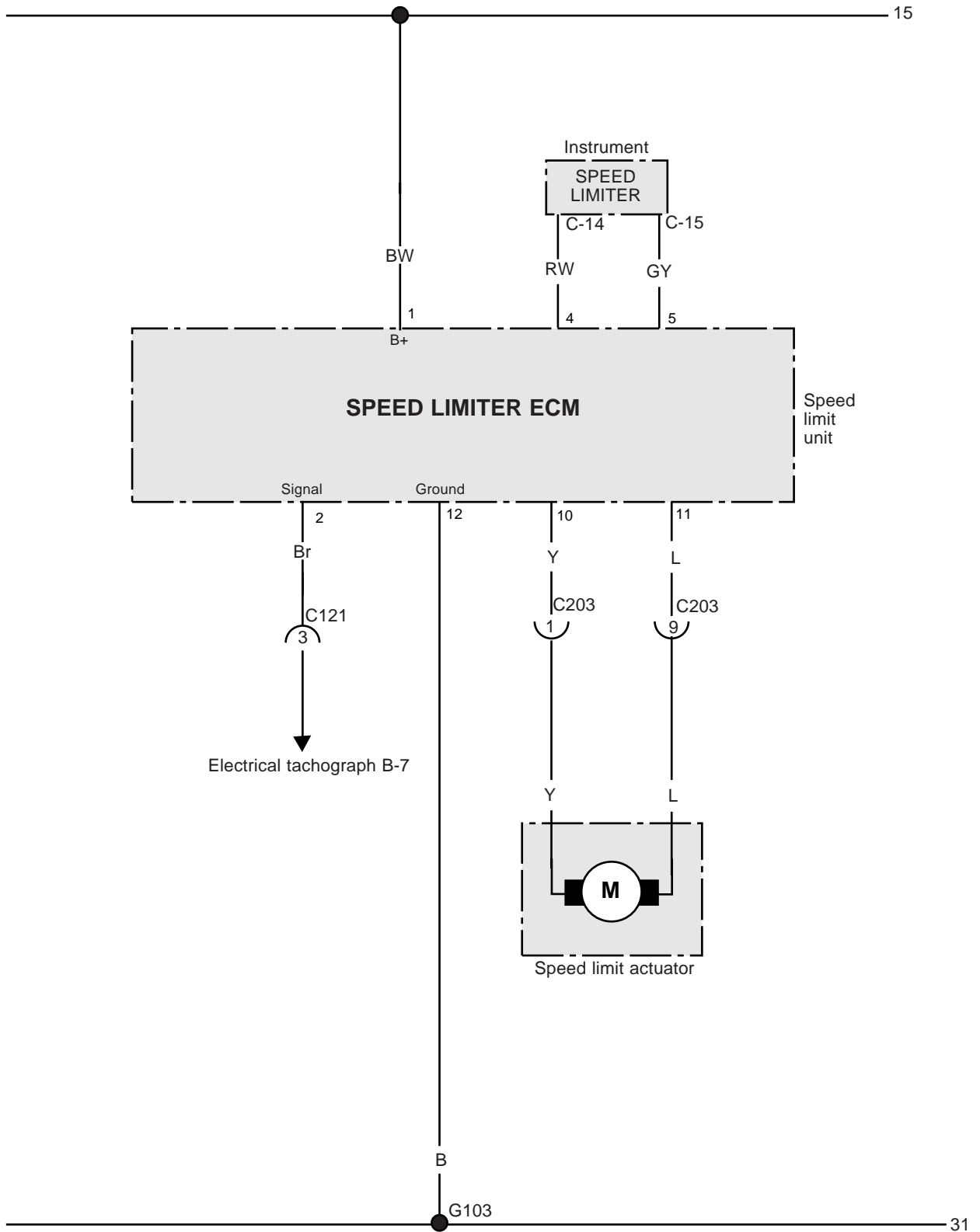

1) CONNECTOR AND PIN NUMBER

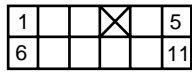

C121, 11pin

Dash - Tachograph harness
(Based on dash harness)

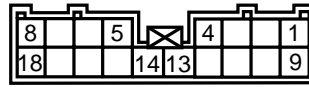

C203, 18pin

Dash - Frame harness
(Based on dash harness)

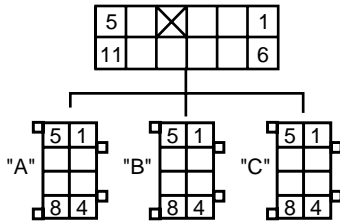

VDO electrical tachograph

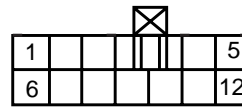

Speed limiter unit

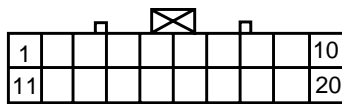

Instrument C
(Based on dash harness)

2) LOCATION OF PARTS

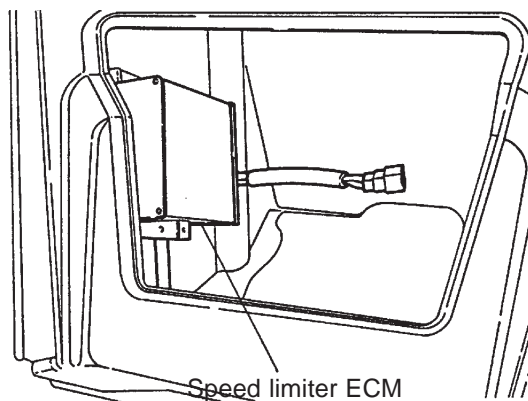

EL051

Speed limiter ECM - Inside the assist seat

28. LOCK BRAKE, DIFFERENTIAL LOCK BRAKE(EXCEPT HUB REDUCTION) CIRCUIT DIAGRAM.

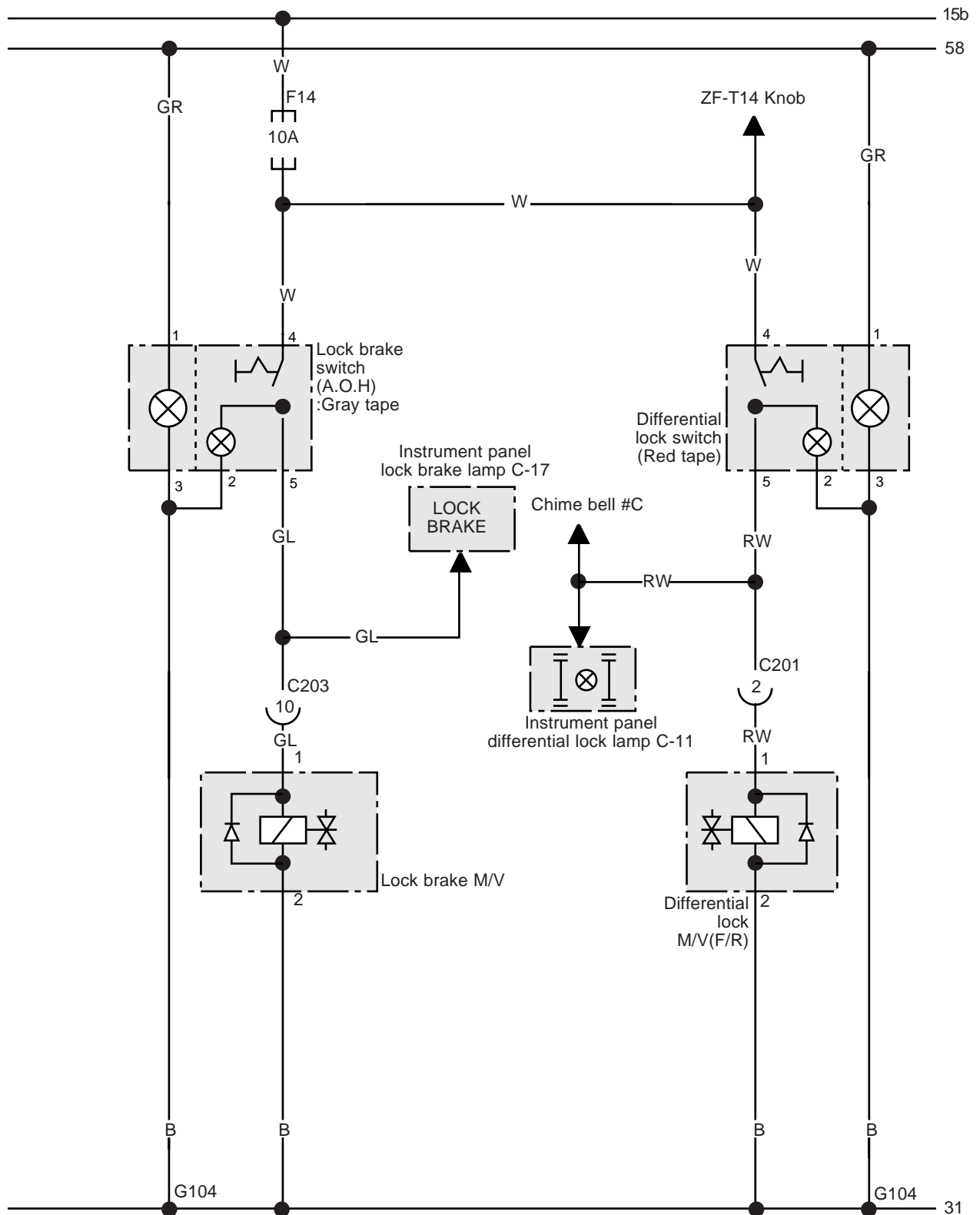

1) CONNECTOR AND PIN NUMBER

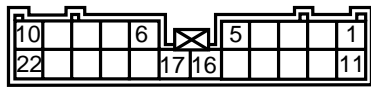

C201, 22pin

Dash - Frame harness
(Based on dash harness)

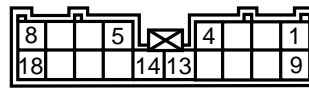

C203, 18pin

Dash - Frame harness
(Based on dash harness)

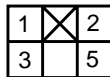

Differential lock/lock brake switch
(Based on dash harness)

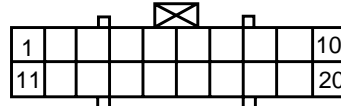

Instrument panel C
(Based on dash harness)

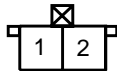

Differential lock/lock brake M/V
(Based on frame harness)

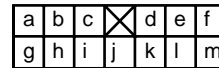

Chime bell unit
(Based on dash harness)

2) LOCATION OF PARTS

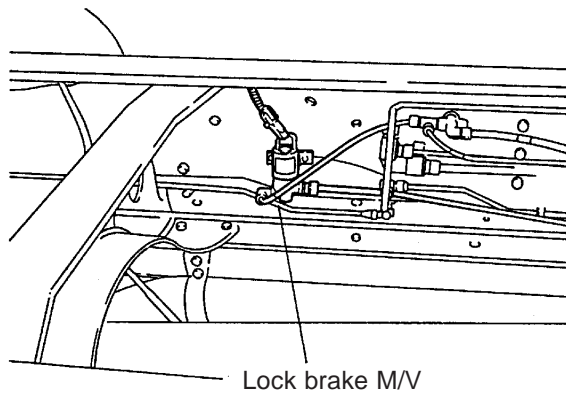

EL054

Lock brake/Differential lock M/V - Inside frame

29. DIFFERENTIAL LOCK (HUB REDUCTION) CIRCUIT DIAGRAM

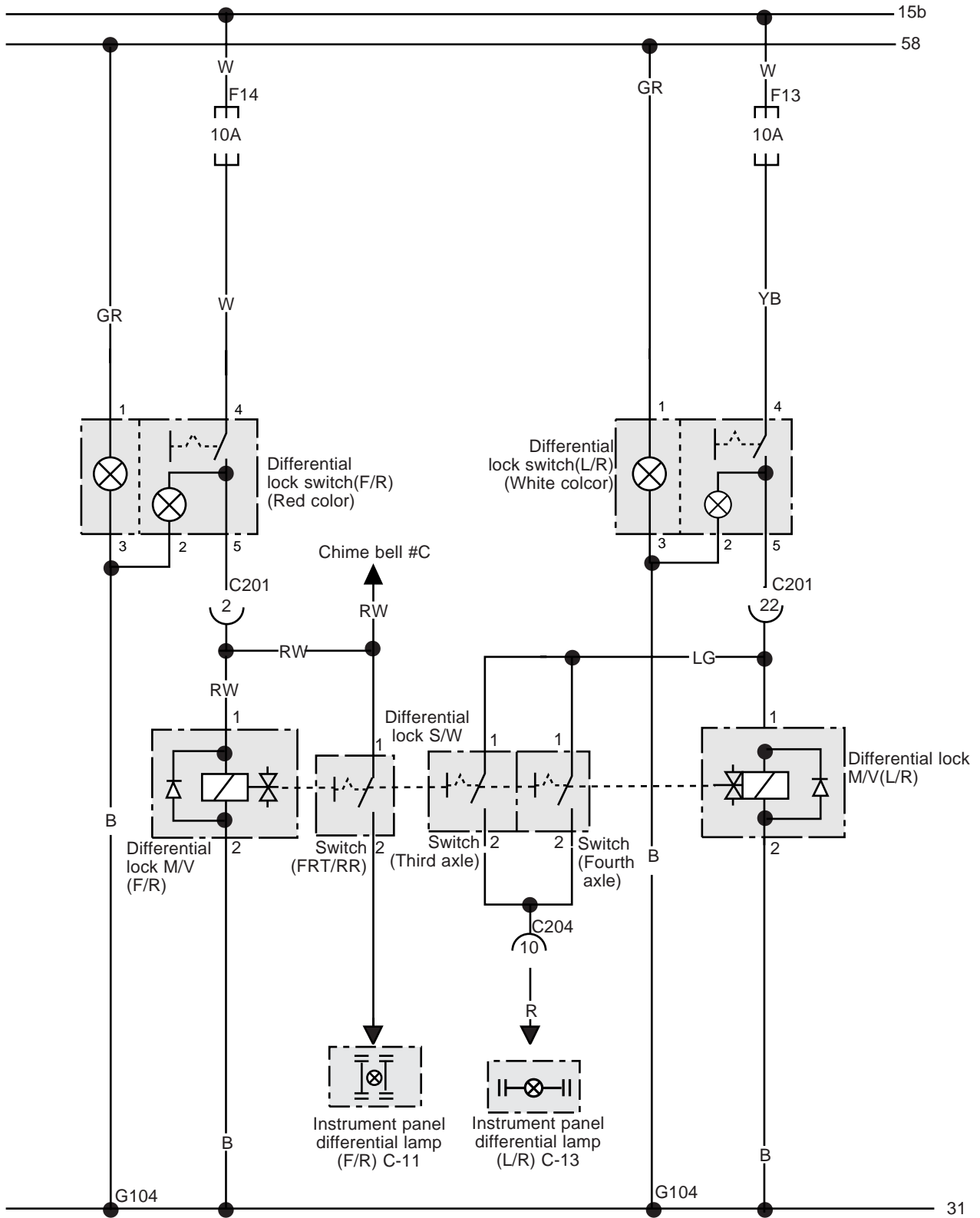

1) CONNECTOR AND PIN NUMBER

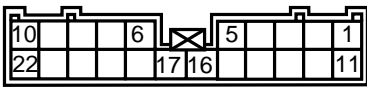

C201, 22pin

Dash - Frame harness
(Based on dash harness)

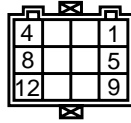

C204, 12pin

Dash-Frame harness
(Based on frame harness)

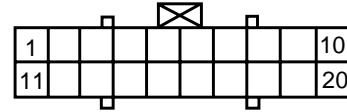

Instrument panel C
(Based on dash harness)

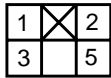

Differential lock switch
(Based on dash harness)



Differential lock M/V
(Based on frame harness)

2) LOCATION OF PARTS

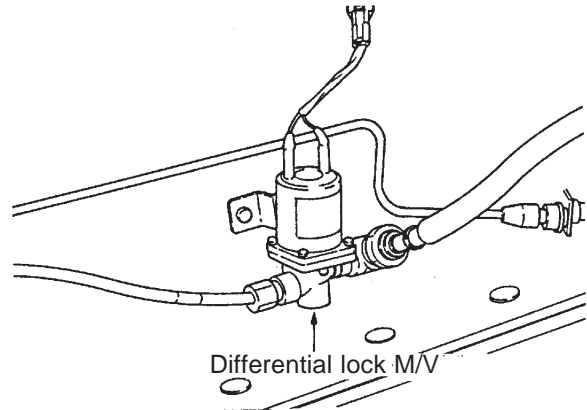
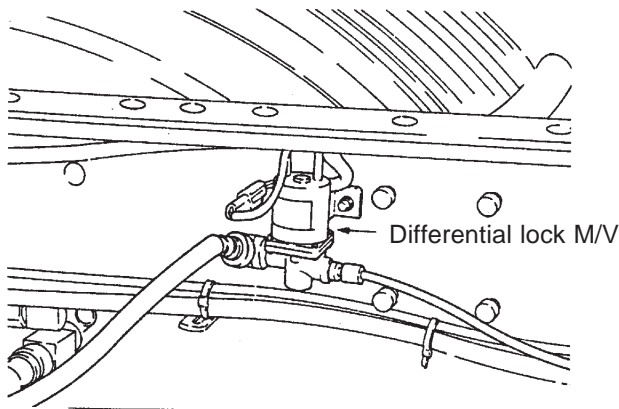

EL056

Differential lock M/V - inside frame

30. WATER PUMP - MIXER DRUM CIRCUIT DIAGRAM

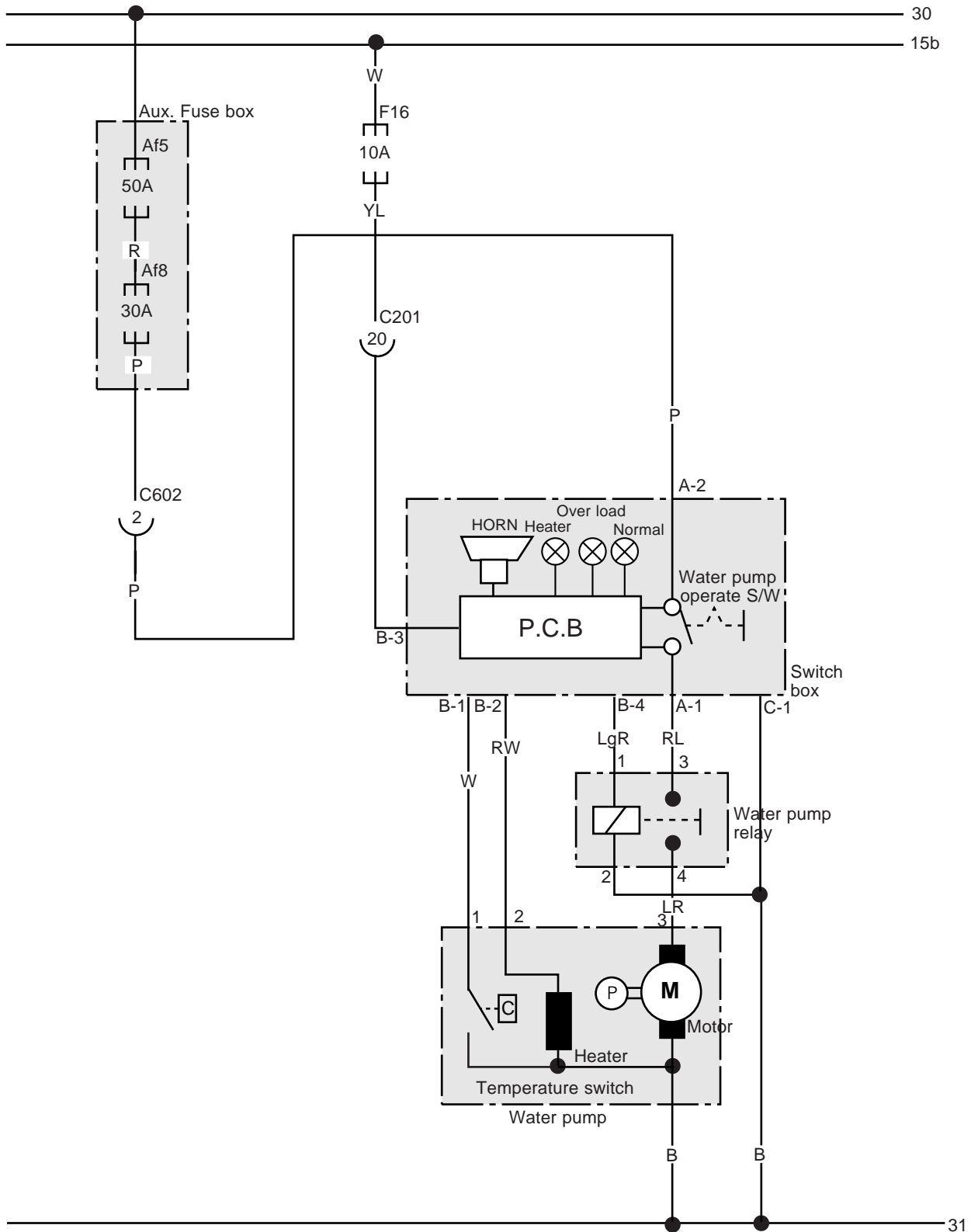

1) CONNECTOR AND PIN NUMBER

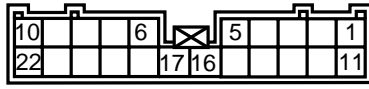

C201, 22pin

Dash - Frame harness
(Based on dash harness)



C602, 2pin

Frame - Aux fuse box harness
(Based on frame harness)

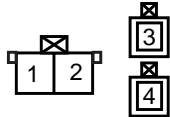

Water pump relay
(Based on frame harness)

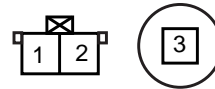

Water pump
(Based on frame harness)

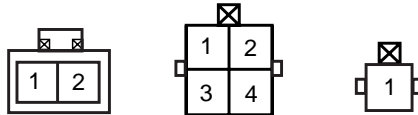

A B C

Switch box
(Based on frame harness)

31. WORKING LAMP, AIR DRYER HEATER CIRCUIT DIAGRAM

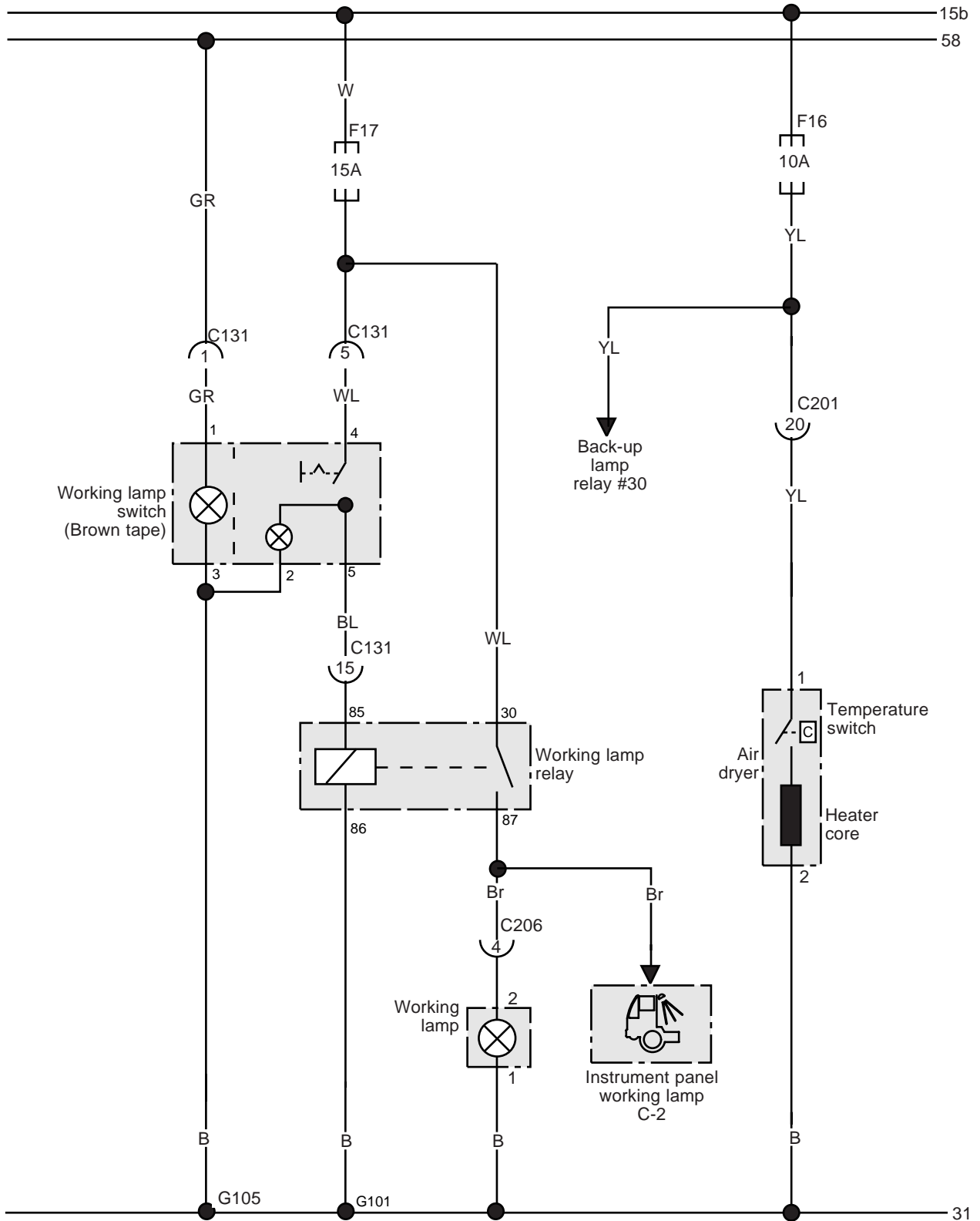

1) CONNECTOR AND PIN NUMBER

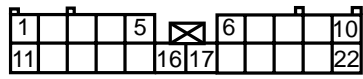

C131, 22pin

Dash - Switch harness
(Based on dash harness)

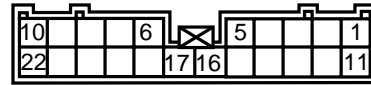

C201, 22pin

Dash - Frame harness
(Based on dash harness)

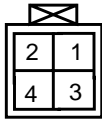

C206, 4pin

Dash - Frame harness
(Based on dash harness)

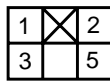

Working lamp switch
(Based on dash harness)

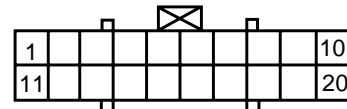

Instrument panel C
(Based on dash harness)

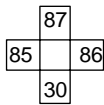

Working lamp relay
(Fuse relay box)

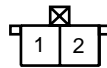

Working lamp
(Based on frame harness)

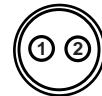

Air dryer
(Based on frame harness)

2) LOCATION OF PARTS

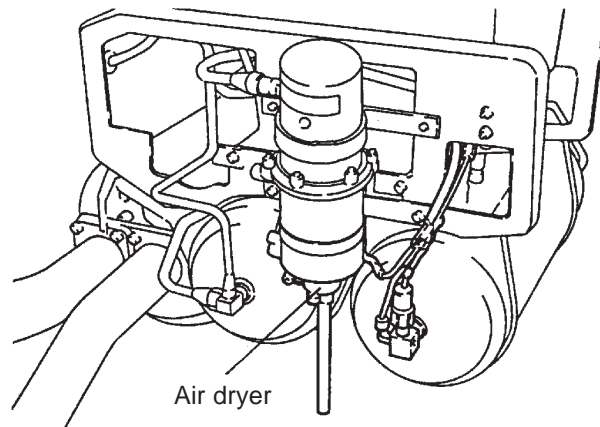

Air dryer

EL058

32. TRAILER CONNECTOR CIRCUIT DIAGRAM

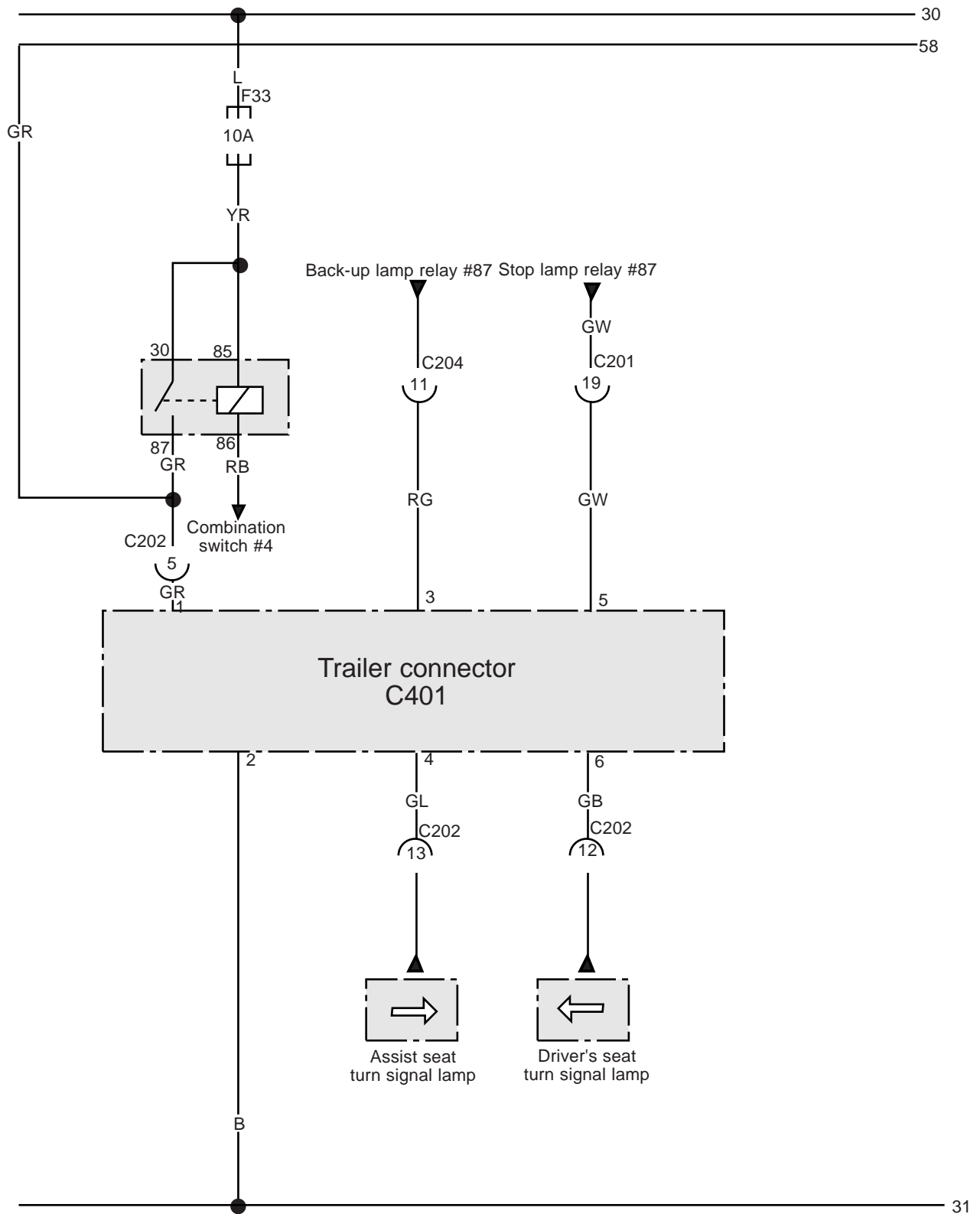

1) CONNECTOR AND PIN NUMBER

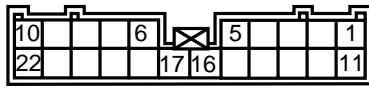

C201, 22pin

Dash - Frame harness
(Based on dash harness)

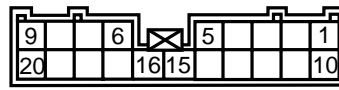

C202, 20pin

Dash - Frame harness
(Based on dash harness)

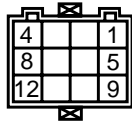

C204, 12pin

Dash - Frame harness
(Based on dash harness)

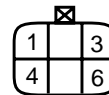

C401, 6pin

Frame - Trailer harness
(Based on frame harness)

33. LIFT AXLE CIRCUIT DIAGRAM

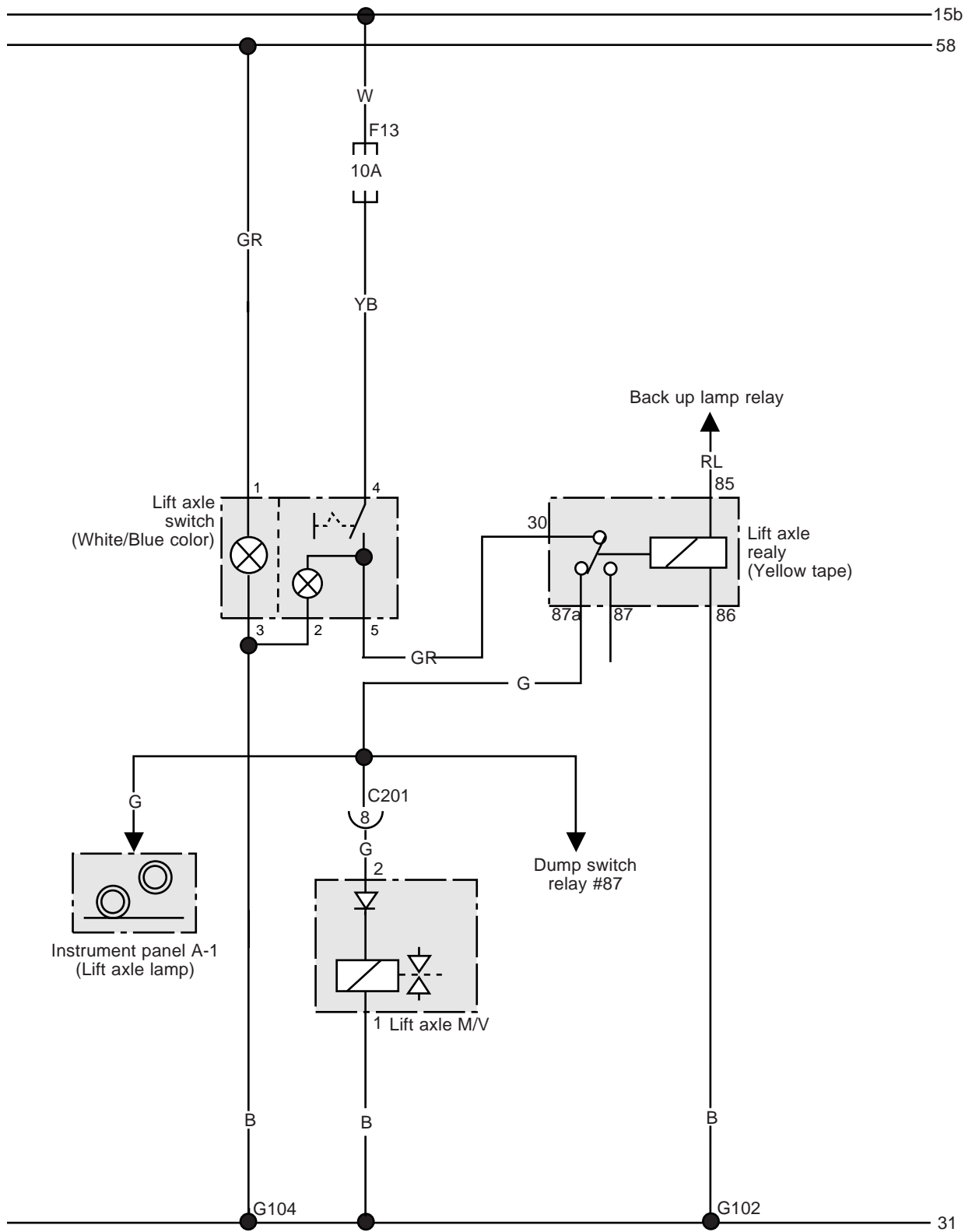

1) CONNECTOR AND PIN NUMBER

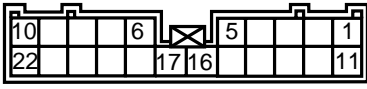

C201, 22pin

Dash - Frame harness
(Based on dash harness)

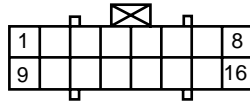

Instrument panel A
(Based on dash harness)

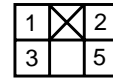

Lift axle S/W
(Based on dash harness)

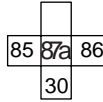

Lift axle relay
(Based on dash harness)

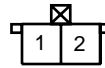

Lift axle M/V
(Based on frame harness)

34. ABS/ASR ELECTRIC CIRCUIT DIAGRAM (D-VERSION)

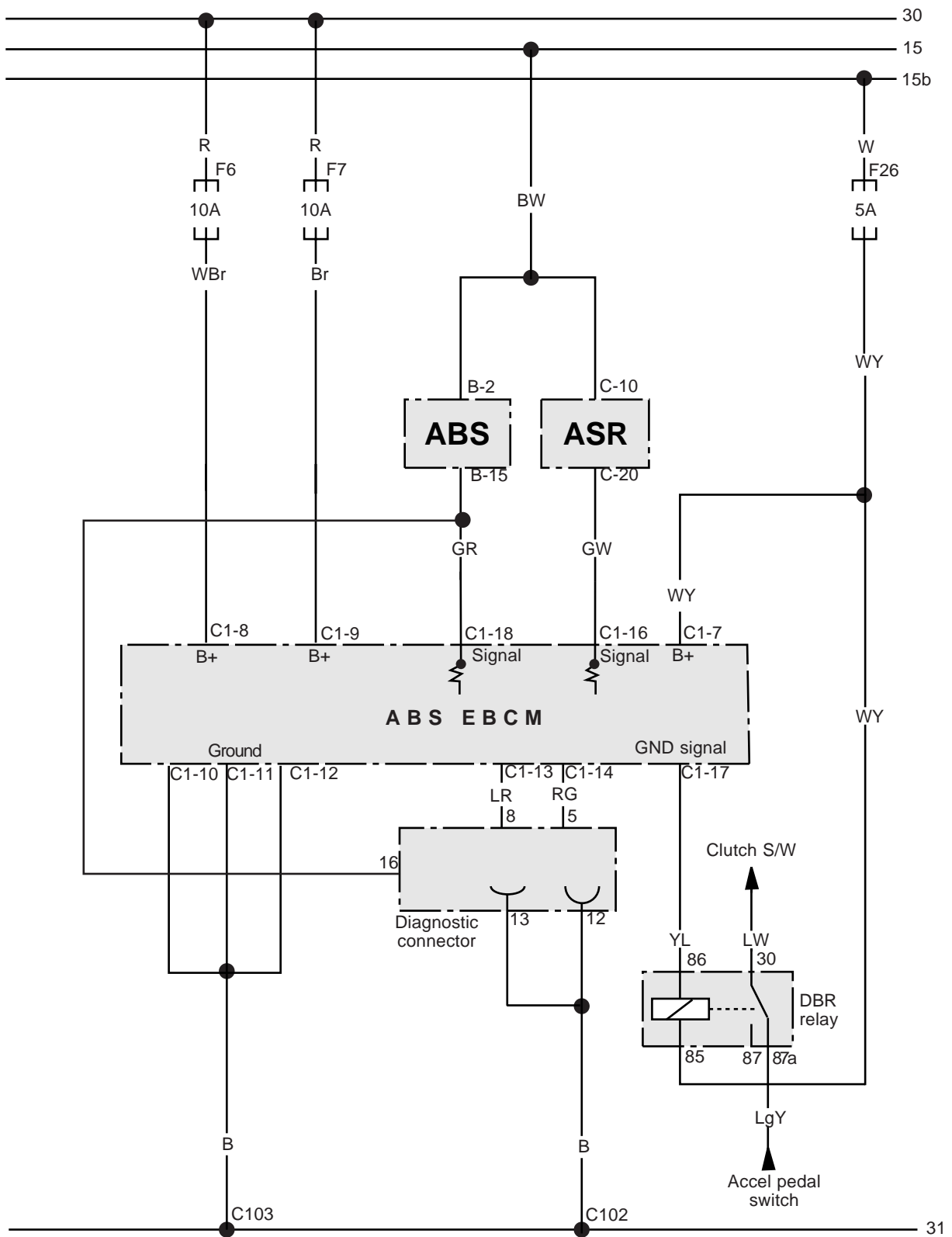

1) CONNECTOR AND PIN NUMBER

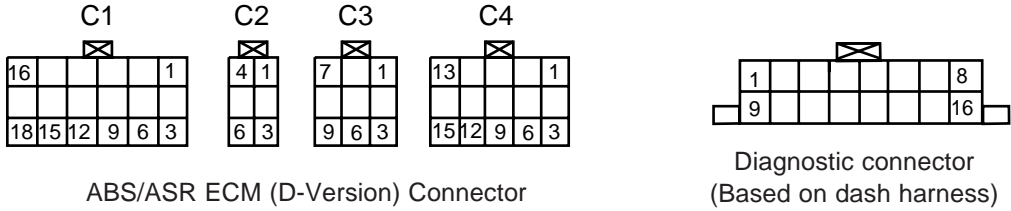

ABS/ASR ECM (D-Version) Connector

Diagnostic connector (Based on dash harness)

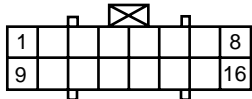

Instrument panel B (Black) (Based on dash harness)

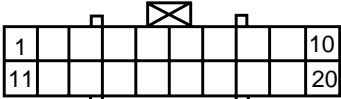

Instrument panel C (Based on dash harness)

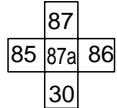

DBR relay (Fuse relay box)

2) LOCATION OF PARTS

(NO.4 Sensor / NO.4 Channel D-version)

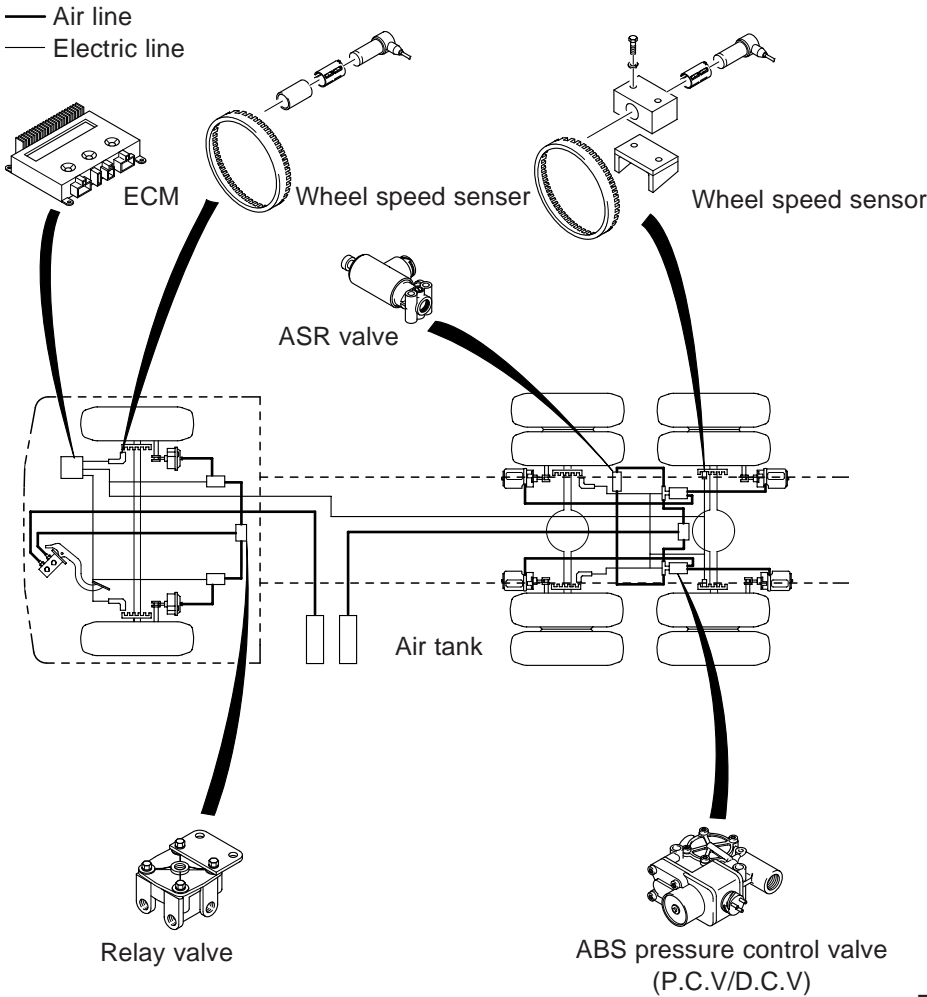

EL062-1

34-1. ABS/ASR PRESSURE CONTROL VALVE, WHEEL SPEED SENSOR CIRCUIT DIAGRAM (NO.4 SENSOR / NO.4 CHANNEL)

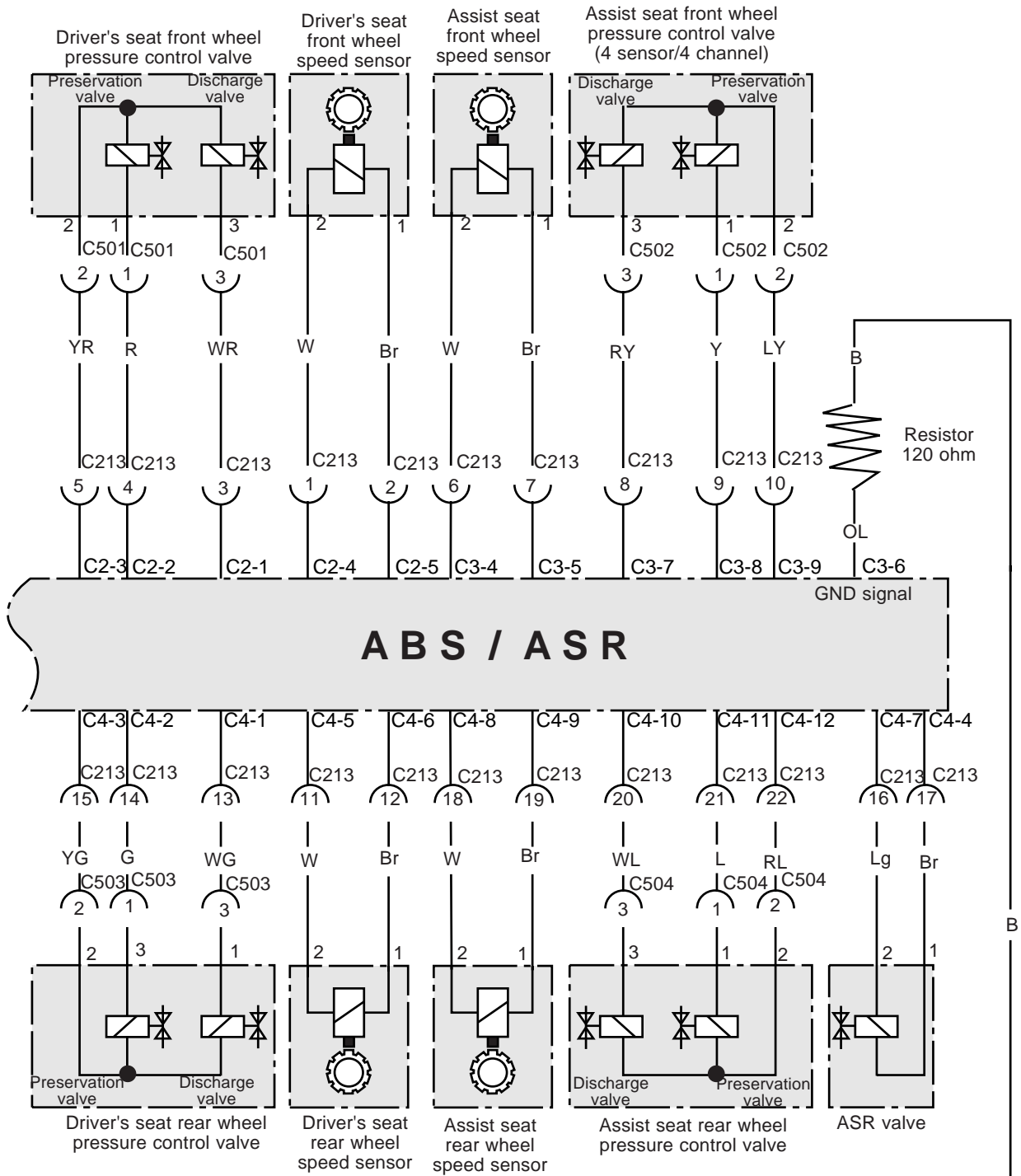

G103 31

1) CONNECTOR AND PIN NUMBER

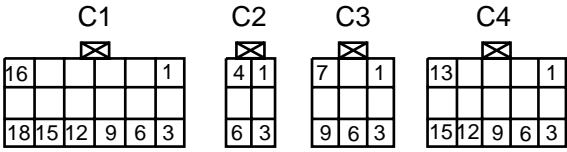

ABS/ASR ECM (D-Version)

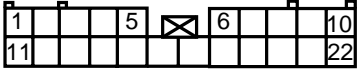

C213, 22pin

ABS/ACR ECM
(Based on dash harness)

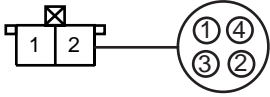

Sub-connector
(Based on frame harness)

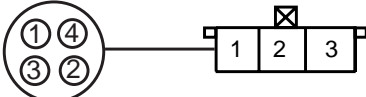

P.C.V
C501-504
(Based on frame harness)

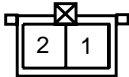

Wheel speed sensor
(Based on frame harness)

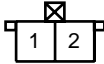

Resistor 120 ohm
(Based on dash harness)

34-2. ABS/ASR PRESSURE CONTROL VALVE, WHEEL SPEED SENSOR CIRCUIT DIAGRAM (AOH: NO.4 SENSOR/NO.3 CHANNEL)

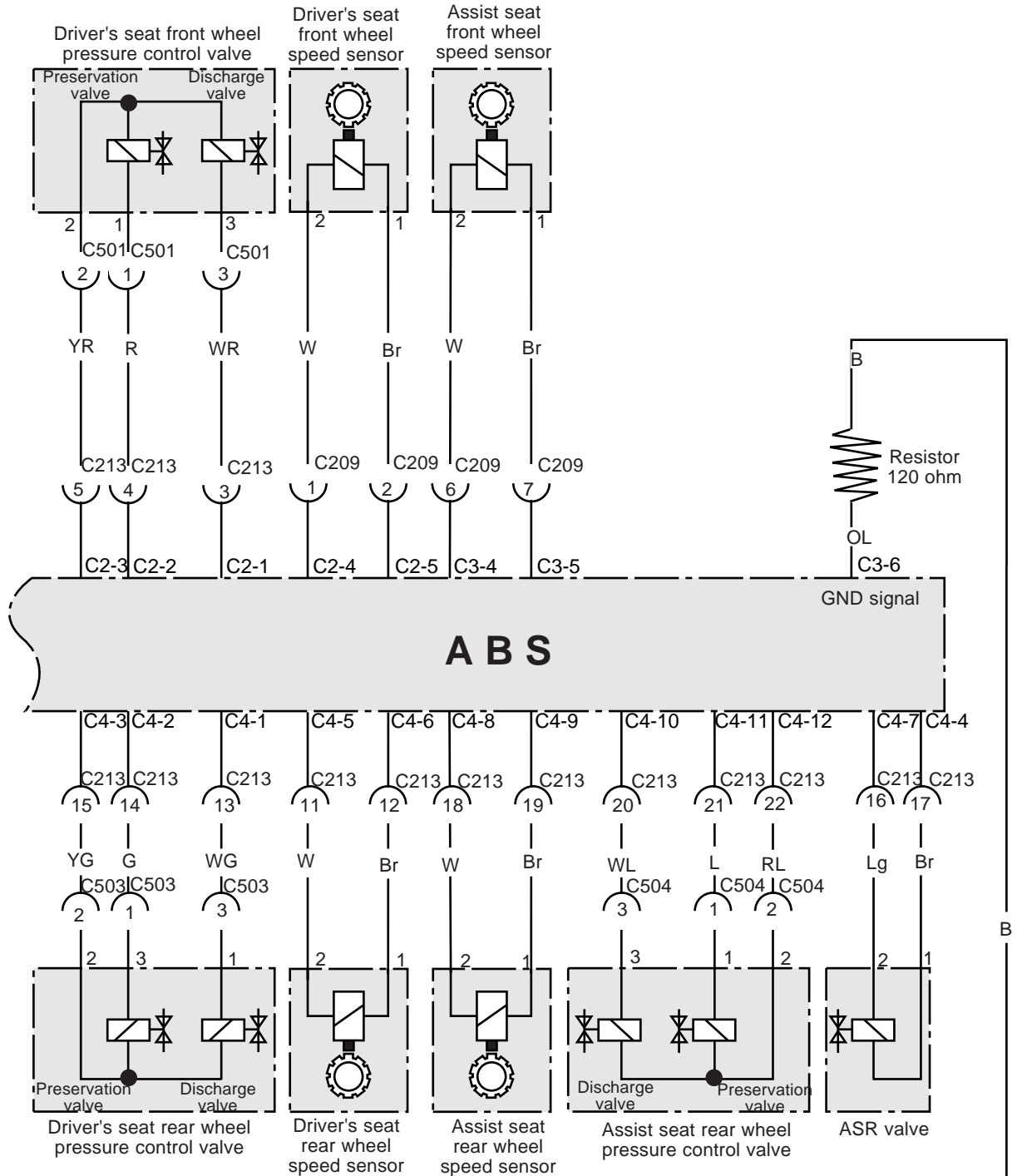

1) CONNECTOR AND PIN NUMBER

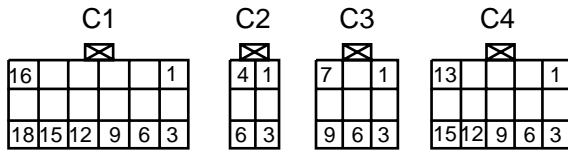

ABS/ASR ECM (D-Version)

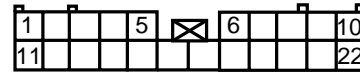

C213, 22pin

ABS/ASR ECM
(Based on dash harness)

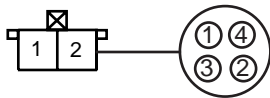

Sub-connector
ASR valve
(Based on frame harness)

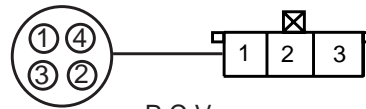

P.C.V
C501-504
(Based on frame harness)

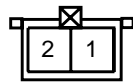

Wheel speed sensor
(Based on frame harness)

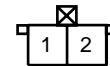

Resistor 120 ohm
(Based on dash harness)

35. ABS ELECTRIC CIRCUIT DIAGRAM (D-VERSION BASIC)

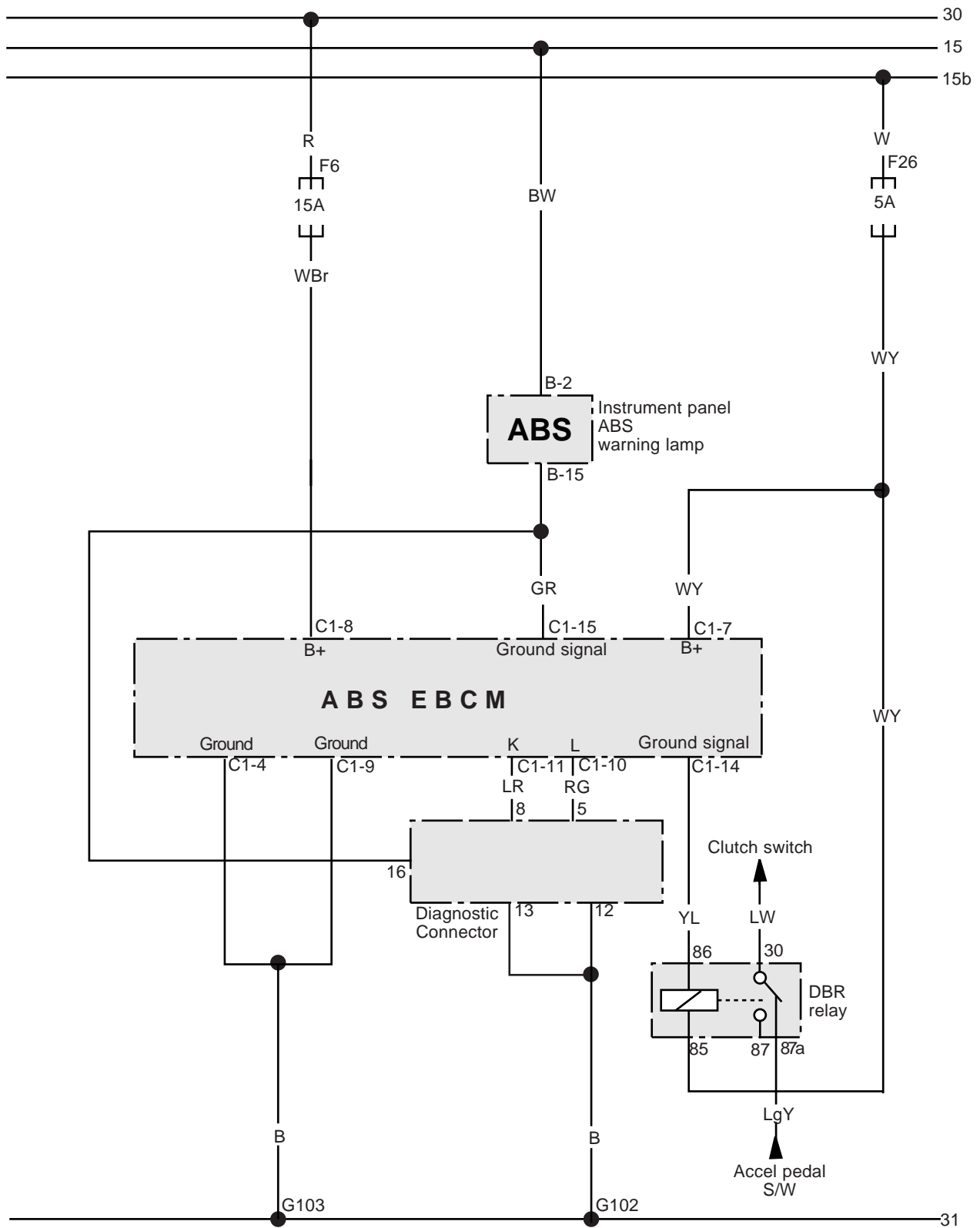

1) CONNECTOR AND PIN NUMBER

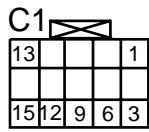

ABS/ASR ECM (D-Version Basic) Connector

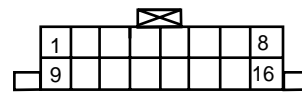
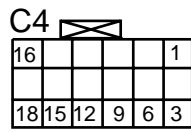

Diagnostic connector
(Based on dash harness)

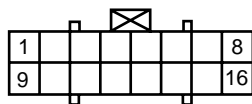

Instrument B
(Based on dash harness)

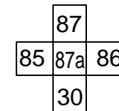

DBR relay
(Fuse relay box)

35-1. ABS PRESSURE CONTROL VALVE, WHEEL SPEED SENSOR CIRCUIT DIAGRAM (D-VERSION)

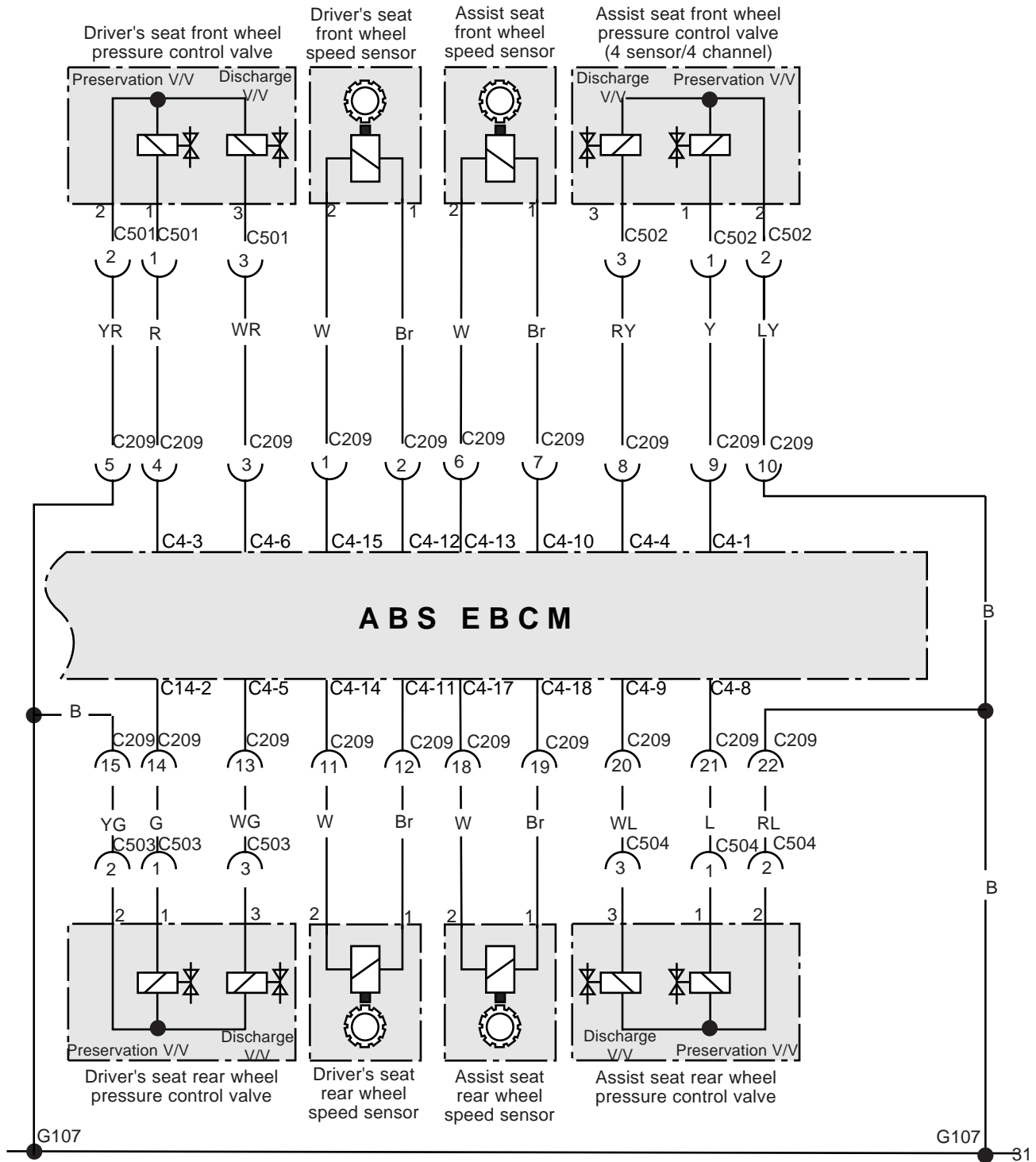

1) CONNECTOR AND PIN NUMBER

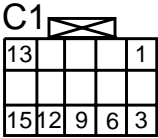

ABS/ASR ECM (D-Version) Connector

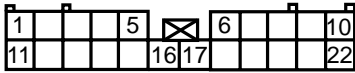
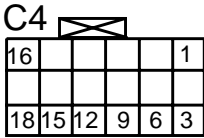

C209, 22pin
Dash - Frame harness
(Based on dash harness)

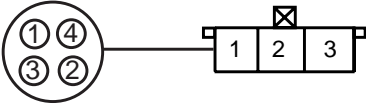

P.C.V
C501-504
(Based on frame harness)

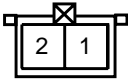

Wheel speed sensor
(Based on frame harness)

36. TRAILER ABS CIRCUIT DIAGRAM (FOR TRACTOR)

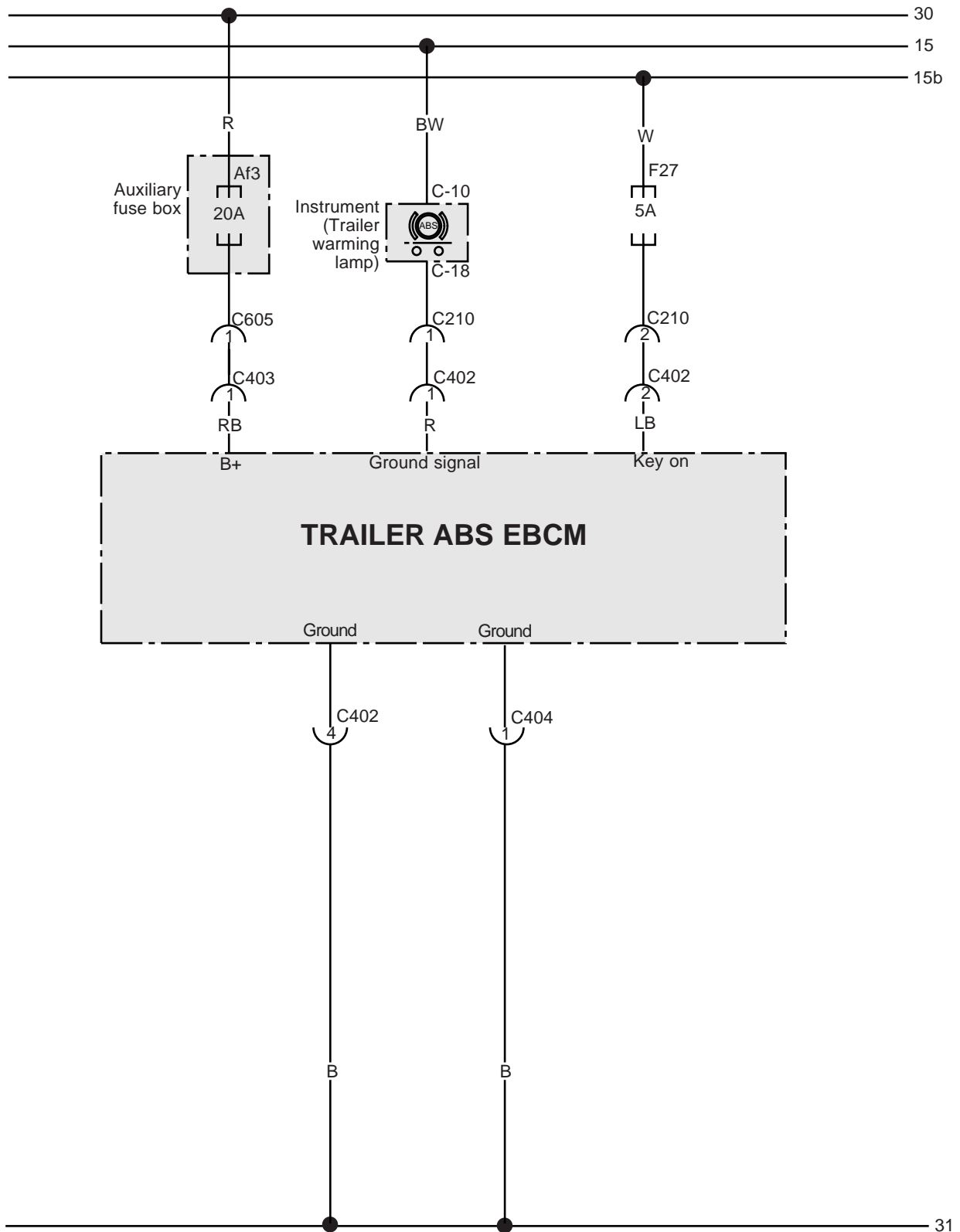

1) CONNECTOR AND PIN NUMBER



C210, 2pin

Dash-frame harness
(Based on dash harness)



C402, 4pin

Frame-trailer harness
(Based on frame harness)



C403, 1pin

Frame-trailer harness
(Based on frame harness)



C404, 1pin

Frame-trailer harness
(Based on frame harness)



C605, 1pin

Frame-Aux fuse box harness
(Based on frame harness)

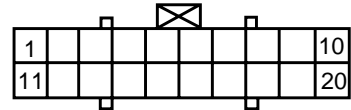

Instrument C (White)
(Based on dash harness)

37. BLINKCODE DESCRIPTION

For blinkcode activation warning lamp respectively the ASR-L has to be grounded for a given time by a push button switch. Which signal lamp has to be used depends on ECU type respectively its parametersetting. The duration defines the mode. After release of the switch the signal light will be on for further 0.5 sec. to confirm that the grounding was detected and accepted by the Electronic Control Unit, ECU.

If a fault occurs or signal lamp is grounded for longer than 6.3 sec. blinkcode will be terminated. If grounding is detected for more than 15 sec., fault detection of warning lamp open circuit can be detected and stored in ECU EEPROM (non-volatile memory). Blinkcode activation on ASR-lamp do not cause fault memorizing because open circuit is not detected.

Dashboard signal lamp check devices which grounds the lamp in the described way activates the related mode.

1) DIAGNOSTIC MODE

For diagnostic mode activation signal lamp has to be grounded for 0.5 sec. to 3.0 sec.

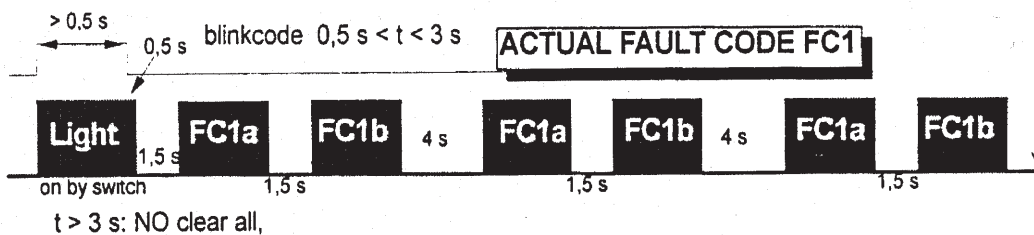

FC : Faultcode // 1 to 8 // a: first part ; b: second part see Blinkcode List
 FC1 repeated because fault is actual

If one fault was detected during current "IGNITION ON" (actual fault) the ECU blinks out that fault. If more faults were detected during that period blinkcode shows just the latest detected fault. For termination ignition must be switched off/on or vehicle has to move (measured speed of more than one axle).

If there is no actual fault, the last fault will be blinked out fist. Further fault numbers may not represent the sequence of occurrence. The stored fault blink mode is self terminating.

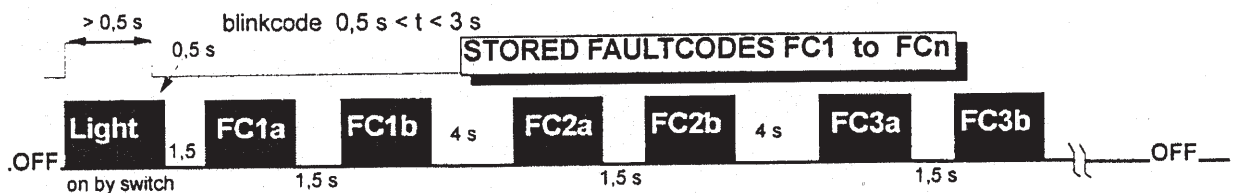

FC : Faultcode // 1 to 8 // a: first part ; b:second part see Blinkcode List

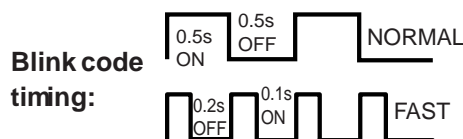

2) SYSTEM MODE, CLEAR

ALL MEMORIZED FAULTS:

System mode is activated if the signal lamp is grounded for a time of 3 to 6.3 sec. All stored faults are erased, if no fault is actual.

For termination ignition has to be switched off / on or vehicle has to move (measured speed of more than one axle).

System code (one number) represents the expected system and should be used to check correct ECU type. After activating system mode ASR(ATC) is disabled for dyno tests. With WL blinkcode ECU's ASR(ATC) lamp is permanently on indicating ASR(ATC) disabling.

Two seconds after system mode activation further functions are available:

1. ASR (ATC) engine control function can be tested by two times extra grounding of a time of >0.5 sec (ASR(ATC) commands idle torque for 10 sec.)
2. ASR(ATC) respectively Retardercontrol system can be reconfigured by three times extra grounding of a time of > 0.5 sec (missing components can be confirmed).
Reconfiguration is confirmed by four short flashes

Without actual fault : CLEARS ALL MEMORIZED FAULTS

CLEAR ALL is accepted and confirmed by 8 short flashes followed by the system code.



Without actual fault

Identical to no actual fault condition but CLEAR ALL is not accepted.

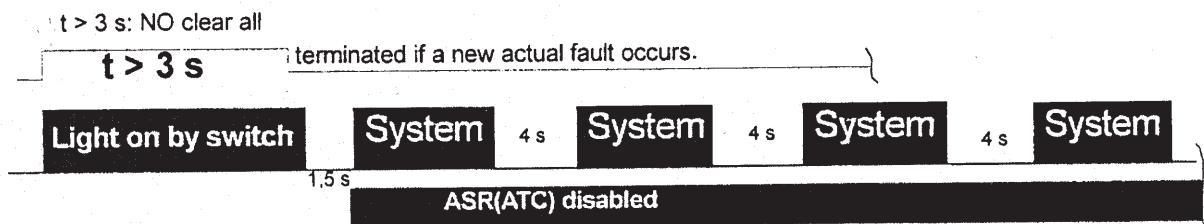

System :	2 x 4S/4M	6 x 4S/3M (VAR rear)
	3 x 4S/3M (MAR/VAR front)	7 x 4S/2M (VAR both)

3) ENGINE CONTROL FUNCTION TEST:

For testing engine control function a 10 sec idle torque can be commanded if the signal lamp is additionally two times grounded. The duration of grounding has to be longer than 0.5 sec. and time between the two grounding has to be less than 3 sec.

The 10 sec. time starts 3 sec. after last grounding. Parallel to the engine control function test the system blinkout continues.

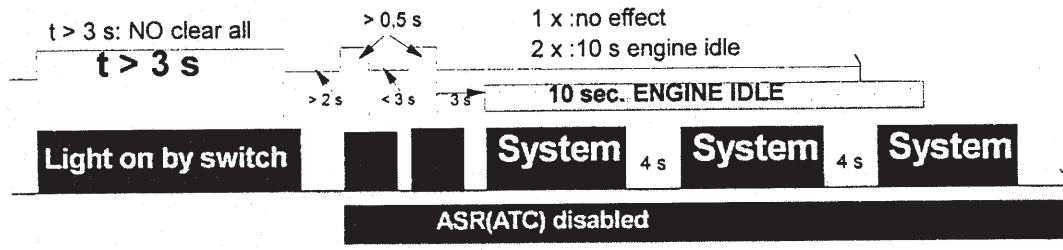

4) RECONFIGURATION:

- The ECU modifies its default system (without ASR/ATC) to ASR/ATC if a differential brake valve and one of the engine control interfaces are connected.
- Connected SAE J1939 (SAE J 1922) without a differential brake valve cause an extension of the supervised ABS components.
- Connected endurance brake relay (DBR output) or received retarder messages on data link (SAE J1922 resp. SAE J1939) stores and extends the ABS components too.

Without reconfiguration such ECU'S could not be used in vehicles without those components. Additional to diagnostic tools this reconfiguration can be done by the means of blinkcode.

To avoid unintentional reconfiguration this function has to be confirmed by three times grounding of the signal lamp in the way described above for engine control function test. Before system code continues 4 short flashes confirm the modification of parameters.

The ASR/ATC lamp bulbtest duration shows whether ASR/ATC is configured or not. Without ASR/ATC: 1,5 sec. ; with ASR/ATC 3 sec. (as Warning Lamp).

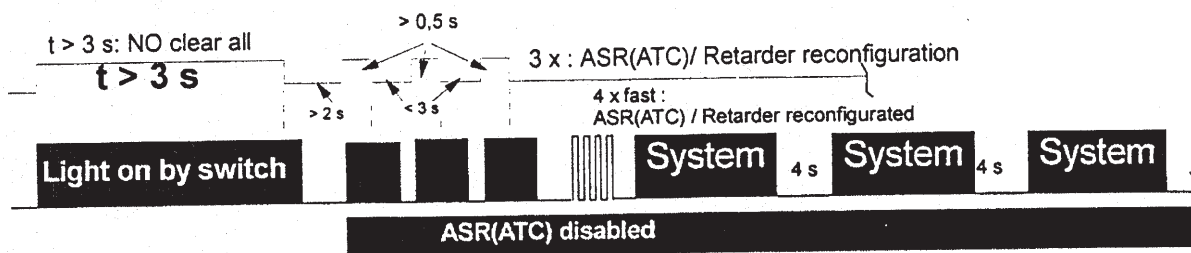

5) DYNOTESTER FUNCTION:

For certain dynotester it is necessary to disable ASR/ATC to allow higher speed difference between driven and steering axle. By activating system mode ASR/ATC can be disabled. With WL Blinkcode ECU's ASR(ATC) lamp is permanently on indicating ASR(ATC) disabling.

To prevent dangerous situations caused by brakeforce in case of ignition off/on or powersupply interupts, ASR/ATC is disabled as long as there are speed differences after ECU reset. For indication the ASR/ATC lamp is permanently on until ignition is switched off/on.

6) BLINKCODE LIST

First faultcodepart (FC.a)	Second faultcodepart (FC.b)
1 NO FAULTS	1 NO FAULTS
2 ABS MODULATOR 3 SENSOR AIR GAP 4 SENSOR SHORT / OPEN 5 SENSOR ERRATIC / TIRE SIZE 6 SENSOR TONE RING	1 RIGHT FRONT 2 LEFT FRONT 3 RIGHT REAR 4 LEFT REAR 5 RIGHT THIRD 6 LEFT THIRD
7 SYSTEM FUNCTION	1 DATA LINK 2 ASR(ATC) VALVE 3 ENDURANCE BRAKE (THIRD BRAKE RELAY) 4 WARNING LAMP 5 ASR(ATC) CONFIGURATION 6 ASR(ATC) PROP/DIF LOCK/STOP VALVE 7 BRAKE SIGNAL
8 ECU	1 POWER SUPPLY LOW 2 POWER SUPPLY HIGH 3 INTERNAL FAULT 4 CONFIGURATION ERROR 5 GROUND

7) FAULTCODES / REPAIR INSTRUCTIONS

2. n	Check modulator wires. Inlet(EV) or outlet(AV) or common wire is permanently or temporarily broken or shorted to plus respectively ground.
3. n	Amplitude of sensor signal is too low. Check bearing play, polewheel run out, push sensor to polewheel. Check sensor wiring and connectors for intermittent contact. Other possible reason: gear engaged at slippery conditions. 16 sec. slip duration.
4. n	Check sensor wiring. Open circuit, short circuit to plus respectively ground or between sensor wires IG/IGM is detected
5. n	Check sensor wiring and connectors for intermittent contact. Check toothed wheel for damages. Check for mismatch-fault of another sensor. Pneu or number of polewheel teeth are different.
6. n	Check polewheel for damages/missing teeth/run out. Use WABCO sensor probe. Replace polewheel if not checked o. k. If additional airgap faults are stored, adjust airgap.
7-1	ECU with PROP : Check wire and speedometer signal. C3/B7 signal calibration, check tyre sizes. Gear switch signals neutral or is manipulated. Electronic engine control: Check wiring respectively other ECU's Excessive slip / dynotester ? One axle was much faster than other?
7-2	Check wire. Output wire is interrupted or grounded or shorted to battery supply.
7-3	Check wire. Output wire is interrupted or grounded or shorted to battery supply. ECU with SAE J1922 resp. SAE J1939: Check other ECU's. No access to the link
7-4	Check wire and bulb. Was blinkcode switch activated longer than 16 s?
7-5	Check wires resp. parameter setting. Diff-brake valve without engine control is detected or CAN, PWM, PROP are detected while selfparameterizing is disabled.
7-6	Check wire. Output wire is interrupted or shorted to ground or battery supply.
7-7	Check brake sensor wiring. Input wire is interrupted or shorted to ground or battery supply.
8-1	Check supply wire and fuse. Supply voltage is temporarily too low
8-2	Check alternator and battery. Supply voltage too high for more than 5 sec.
8-3	Replace ABS(ASR) electronic if fault detection repeats.
8-4	No modulators connected or wrong ECM or wrong parameterized
8-5	Check ECU ground wires and common modulator wires

BLANK

38. SERVICE ELECTRIC EQUIPMENTS FOR USER CIRCUIT DIAGRAM

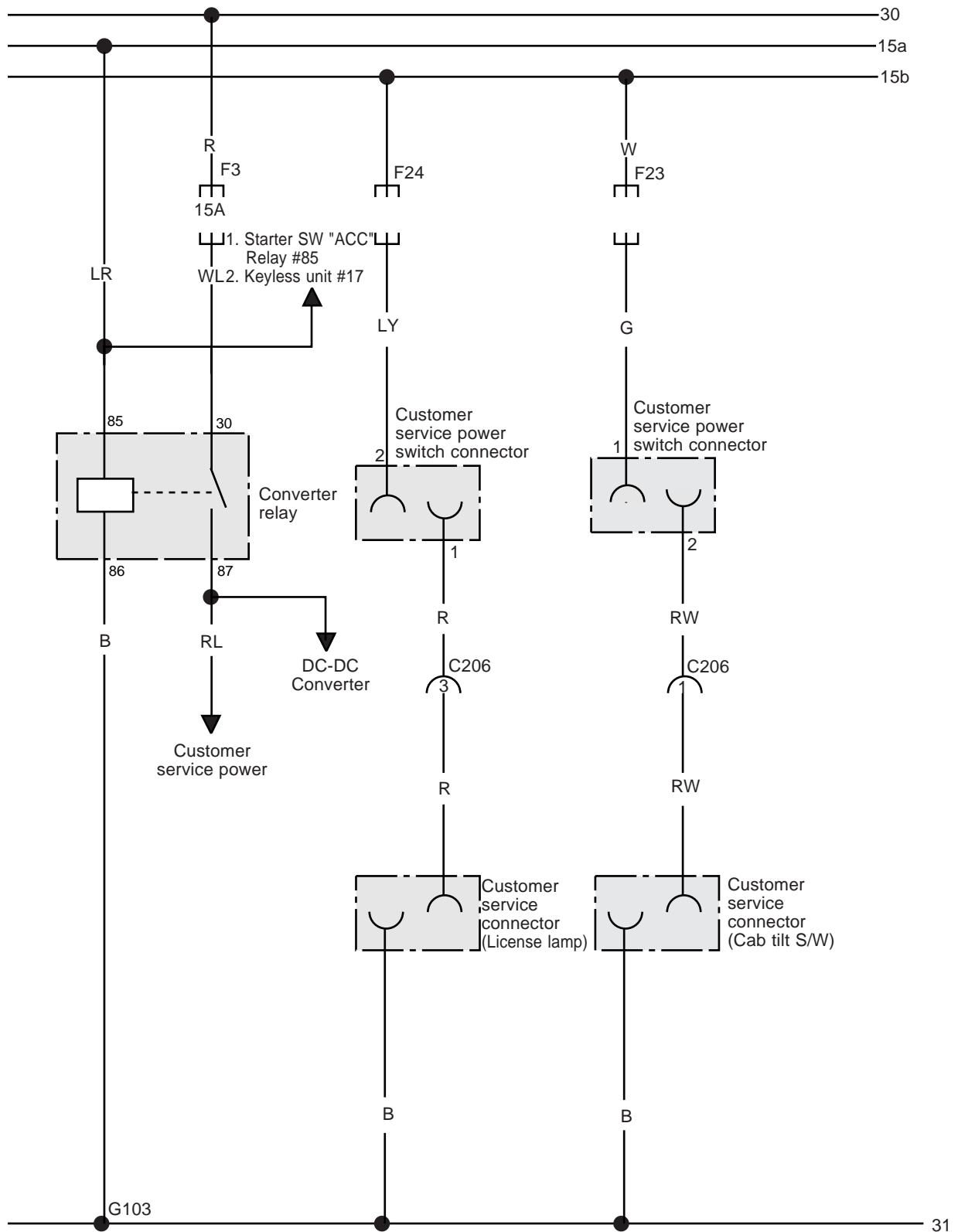

1) CONNECTOR AND PIN NUMBER

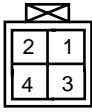

C206, 4pin

Dash-frame harness
(Based on dash harness)

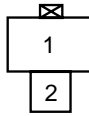

Customer service S/W connector
(Based on dash harness)

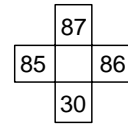

Converter relay
(Fuse relay box)

39. DE12TIS ECM POWER, RACK SENSOR, RPM SENSOR CIRCUIT DIAGRAM

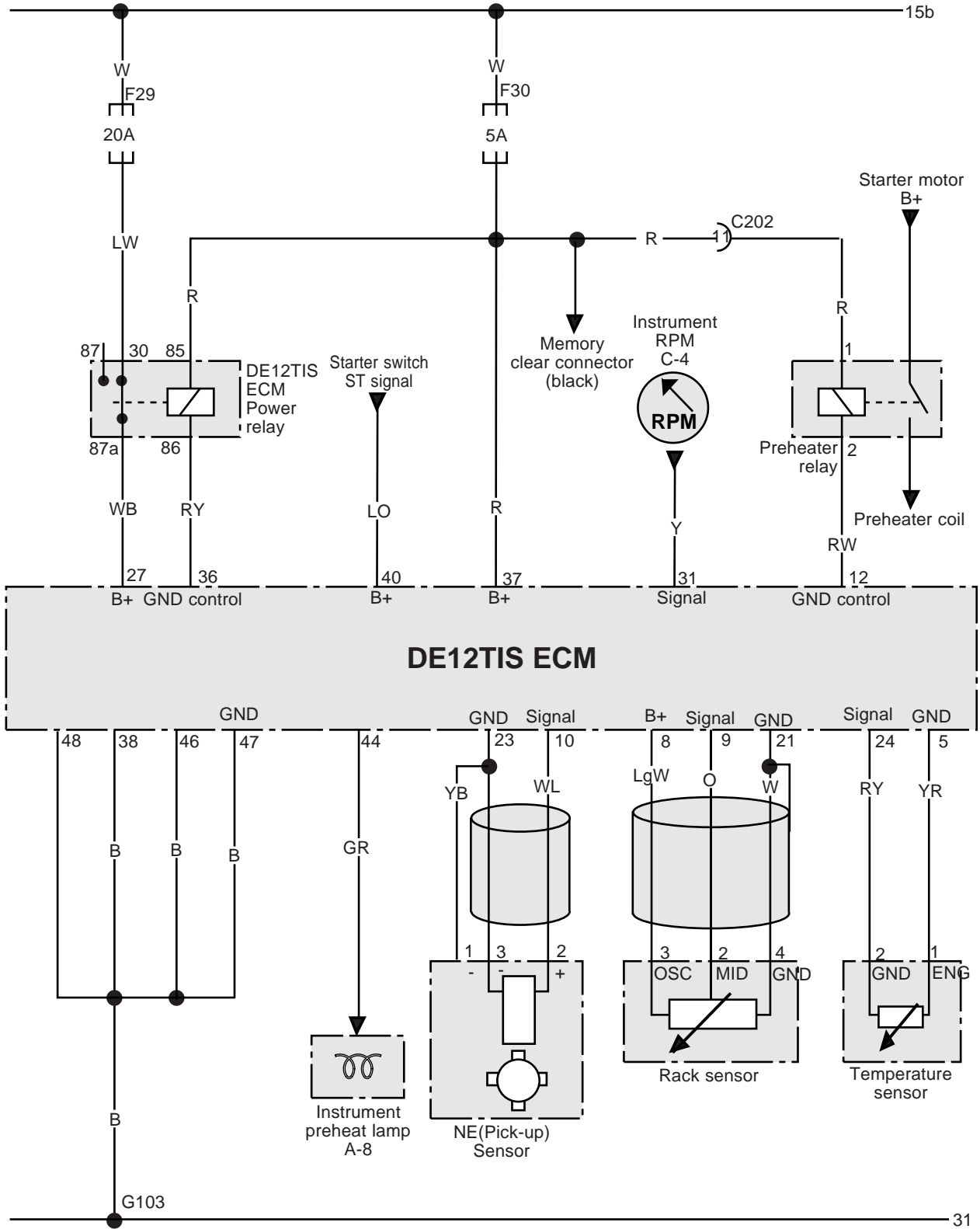

1) CONNECTOR AND PIN NUMBER

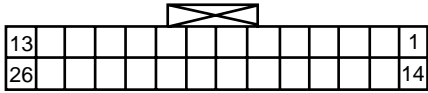

DE12TIS ECM Frame harness connector

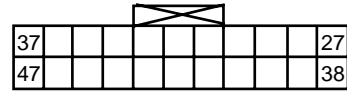

DE12TIS ECM Dash harness connector



Temperature sensor connector
(Based on dash harness)

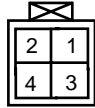

Rack sensor
(Based on frame harness)



NE(pick-up) sensor connector

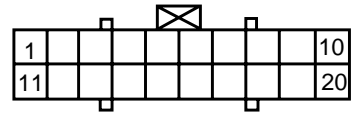

Instrument C (White)
(Based on dash harness)

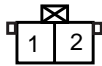

Airheater relay
(Based on frame harness)

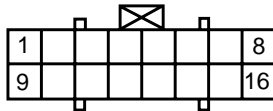

Instrument A (White)
(Based on dash harness)

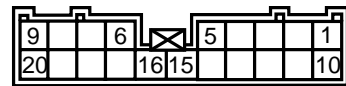

C202, 20pin
(Based on dash harness)

40. DE12TIS DIAGNOSTIC, PREST SENSOR AND ACTUATOR CIRCUIT DIAGRAM

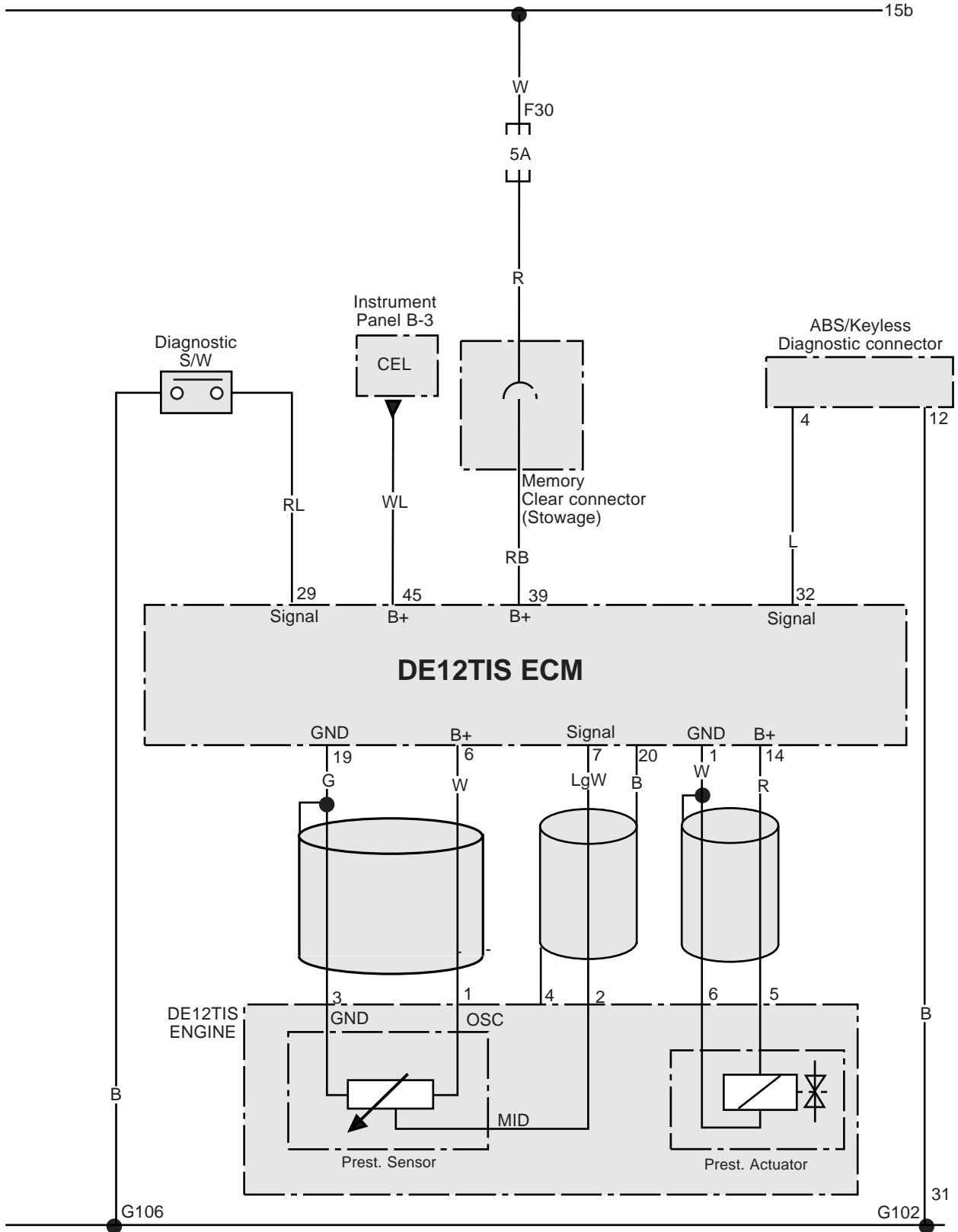

1) CONNECTOR AND PIN NUMBER

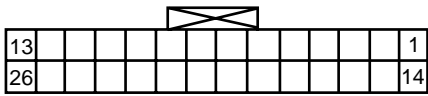

DE12TIS ECM Frame harness connector

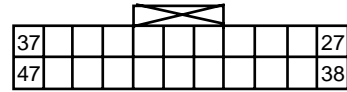

DE12TIS ECM Dash harness connector

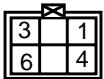

Prest. actuator connector

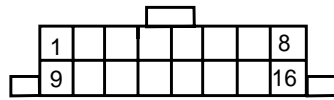

Diagnostic connector
(Based on dash harness)

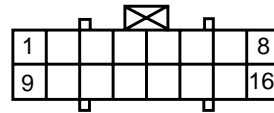

Instrument B
(Based on dash harness)

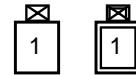

DE12TIS Memory clear connector

41. INSTRUMENT SYSTEM CIRCUIT DIAGRAM
41-1. INSTRUMENT SYSTEM FOR DE ENGINE CIRCUIT DIAGRAM

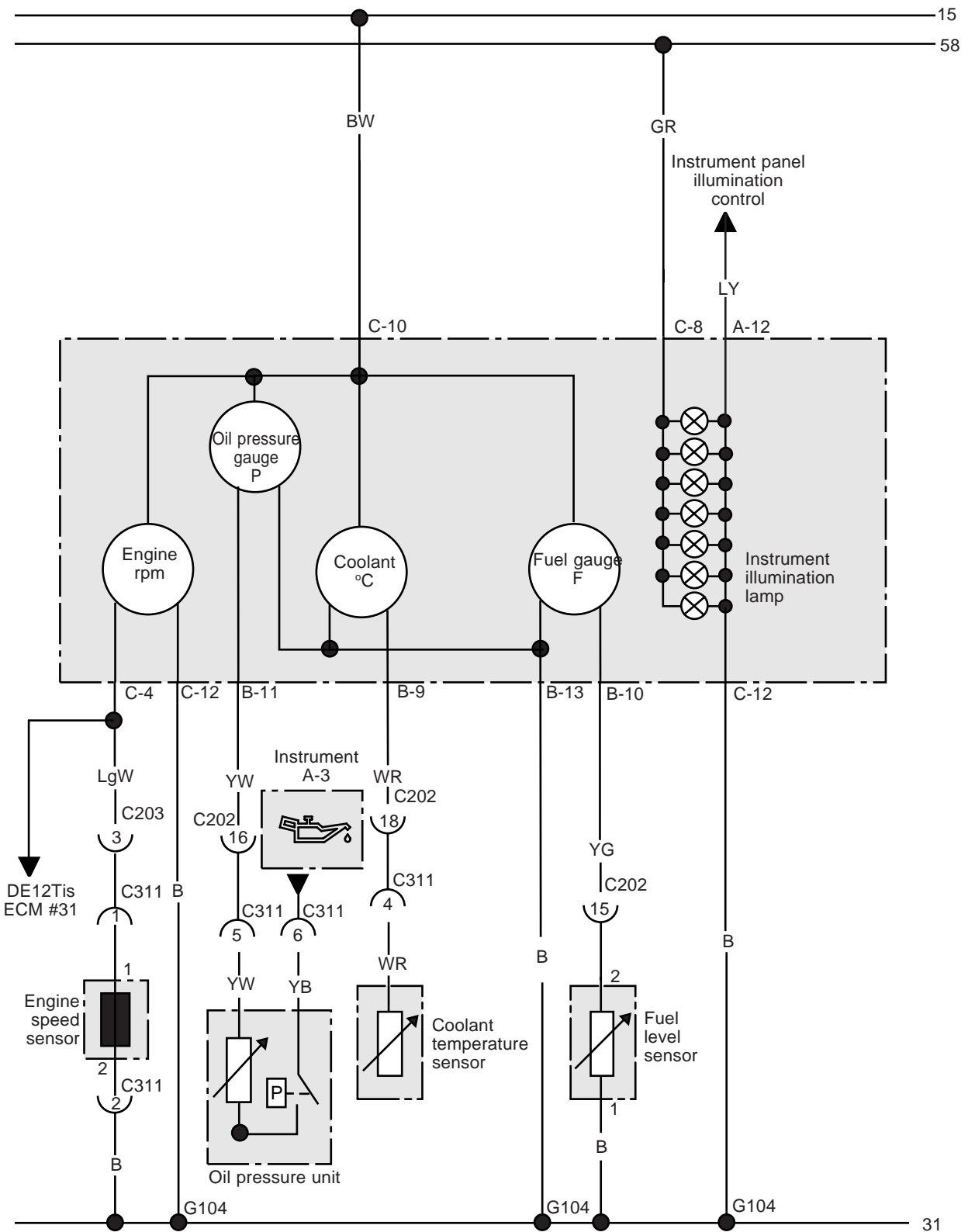

1) CONNECTOR AND PIN NUMBER

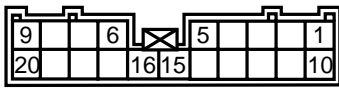

C202, 20pin

Dash-frame harness
(Based on dash harness)

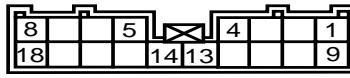

C203, 18pin

Dash-frame harness
(Based on dash harness)

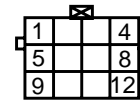

C311, 12pin

Frame-engine harness
(Based on frame harness)

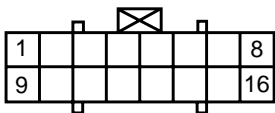

A

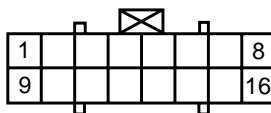

B(Black)

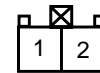

Fuel level sensor
(Based on frame harness)

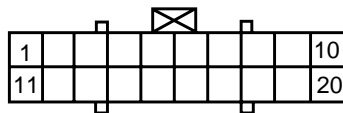

C

Instrument connector

2) LOCATION OF PARTS

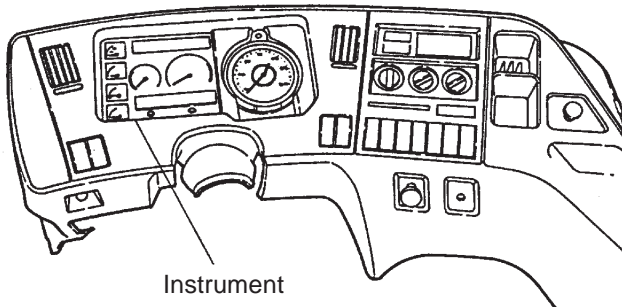

Instrument

I.P panel

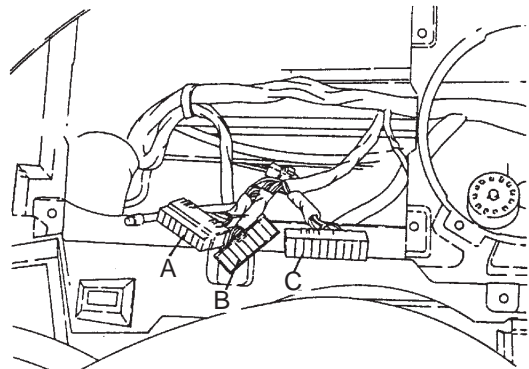

EL073

Instrument connector

41-2. INSTRUMENT SYSTEM FOR DV ENGINE CIRCUIT DIAGRAM

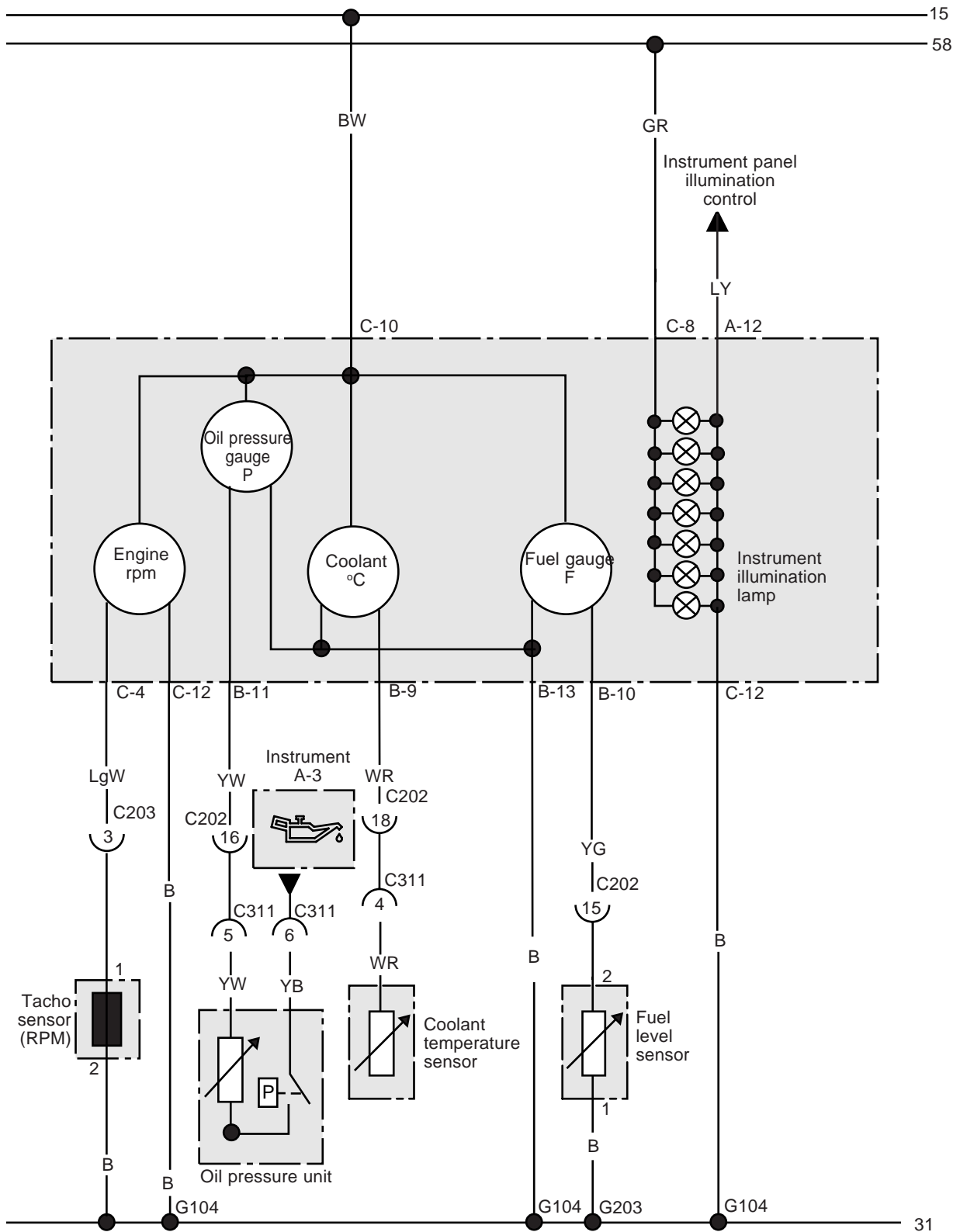

1) CONNECTOR AND PIN NUMBER

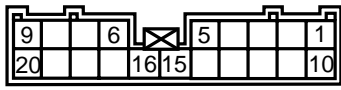

C202, 20pin

Dash-frame harness
(Based on dash harness)



C203, 18pin

Dash-frame harness
(Based on dash harness)

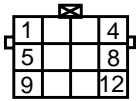

C311, 12pin

Frame-engine harness
(Based on frame harness)

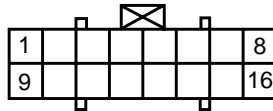

A

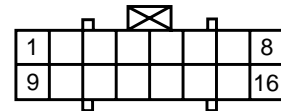

B(Black)

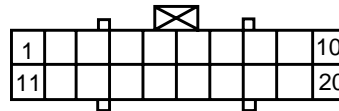

C

Instrument connector

2) LOCATION OF PARTS

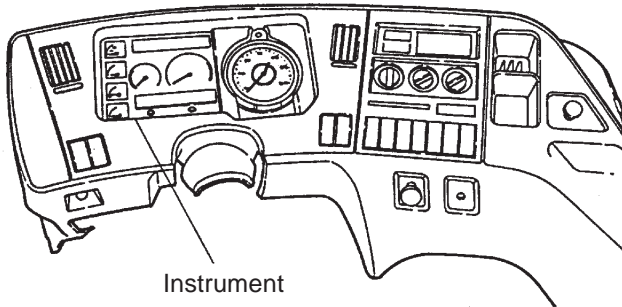

Instrument

I.P panel

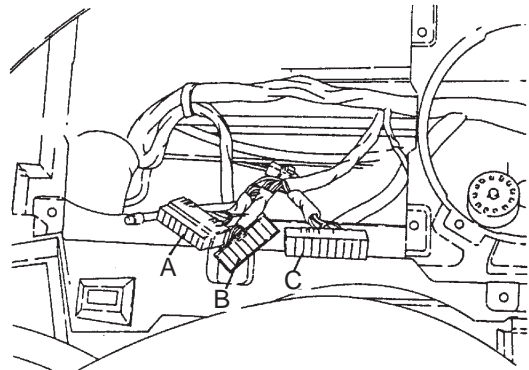

EL073

Instrument connector

41-3. INDICATOR LAMP OF INSTRUMENT CIRCUIT DIAGRAM (PREHEAT, LIFT AXLE, CAB TILT LAMP ETC.)

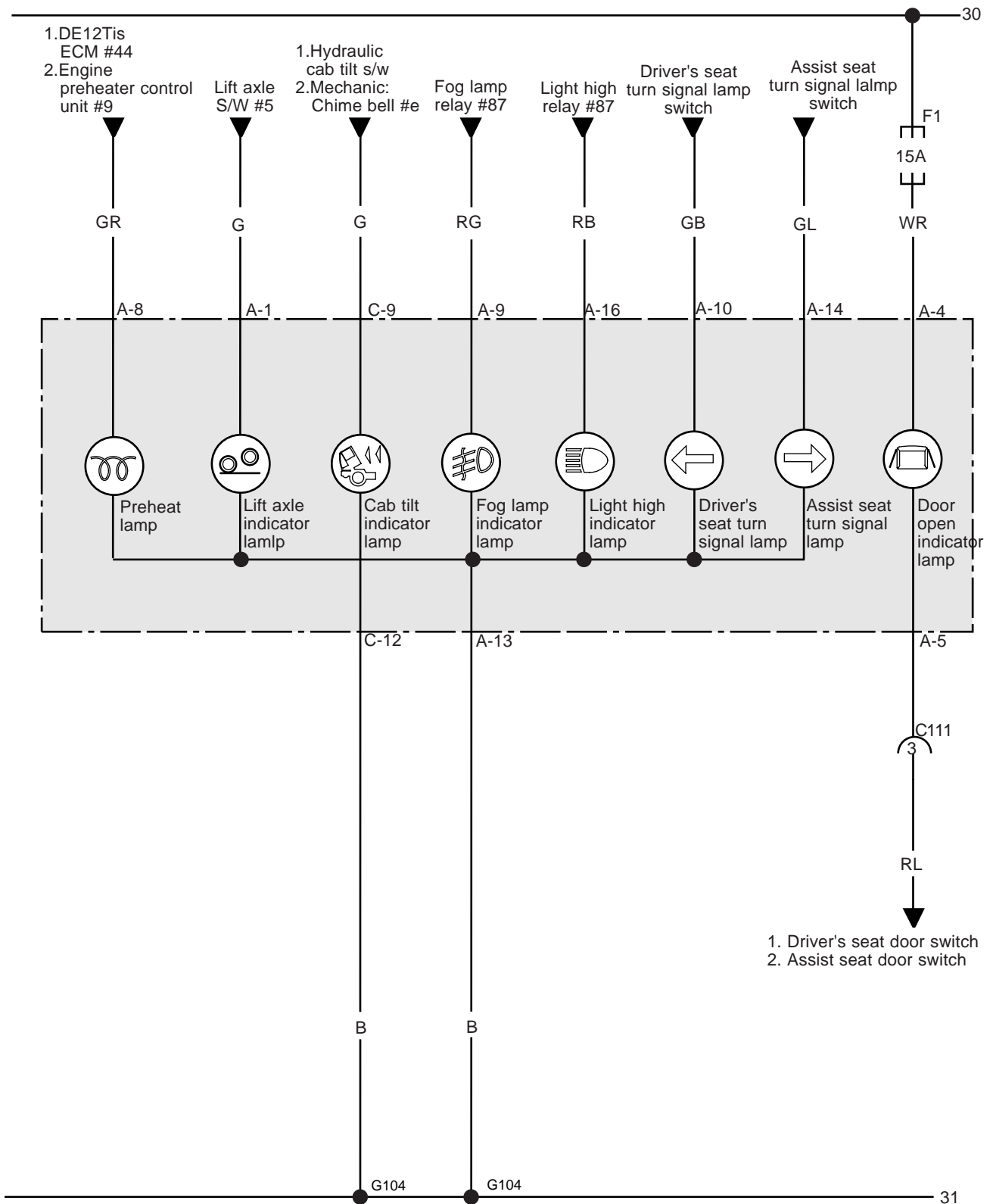

1) CONNECTOR AND PIN NUMBER

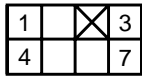

C111, 7pin

Dash-Roof harness
(Based on dash harness)

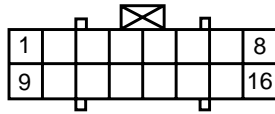

A

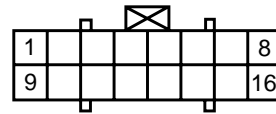

B(Black)

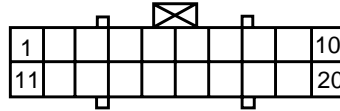

C

Instrument connector

**41-4. INDICATOR LAMP OF INSTRUMENT CIRCUIT DIAGRAM
(PTO LAMP, DIFFERENTIAL LOCK LAMP ETC.)**

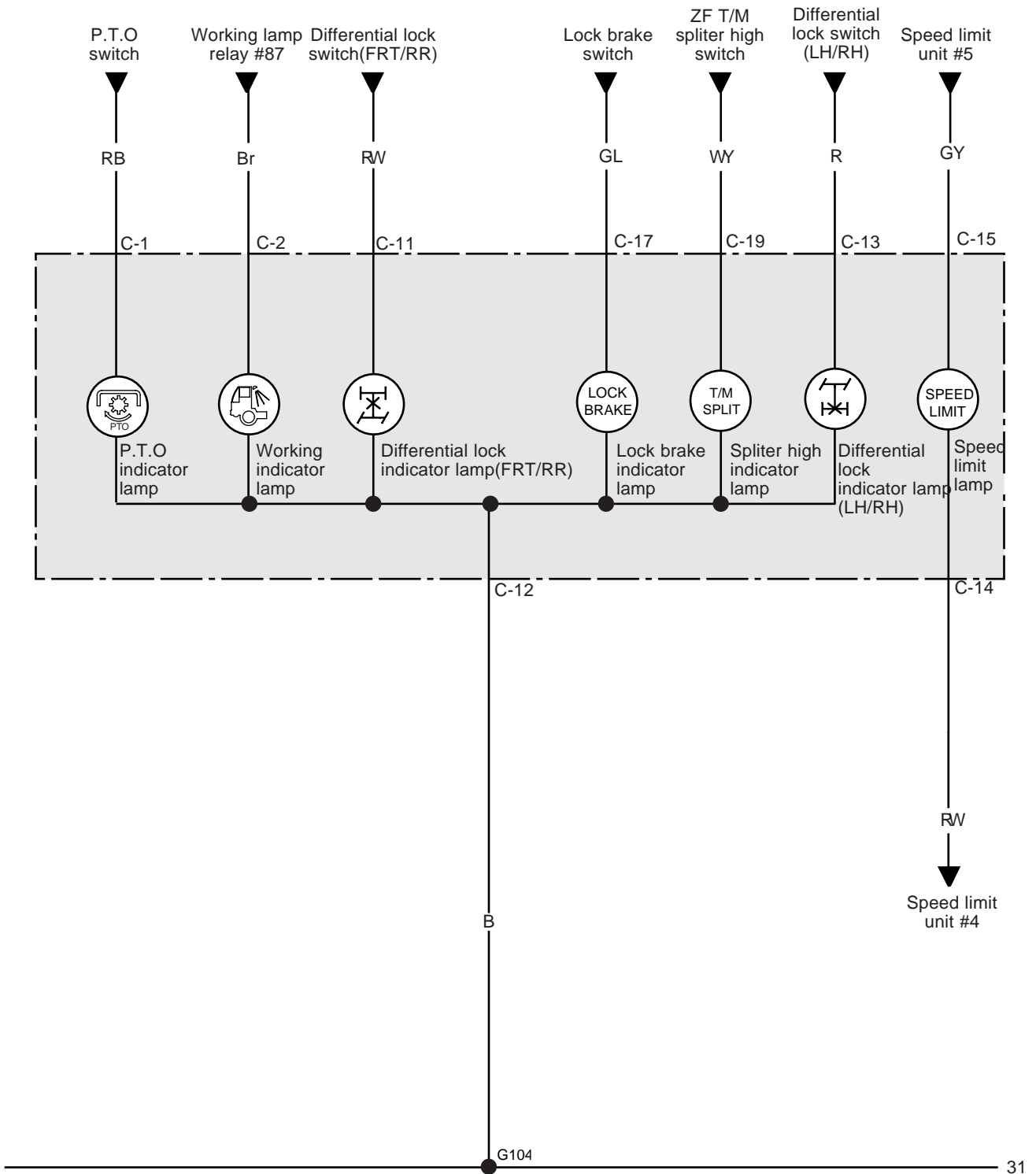

41-5. SWITCH AND WARNING LAMP CIRCUIT DIAGRAM (EXHAUST BRAKE, CHECK ENGINE, ABS/ASR, TRAILER BRAKE LAMP)

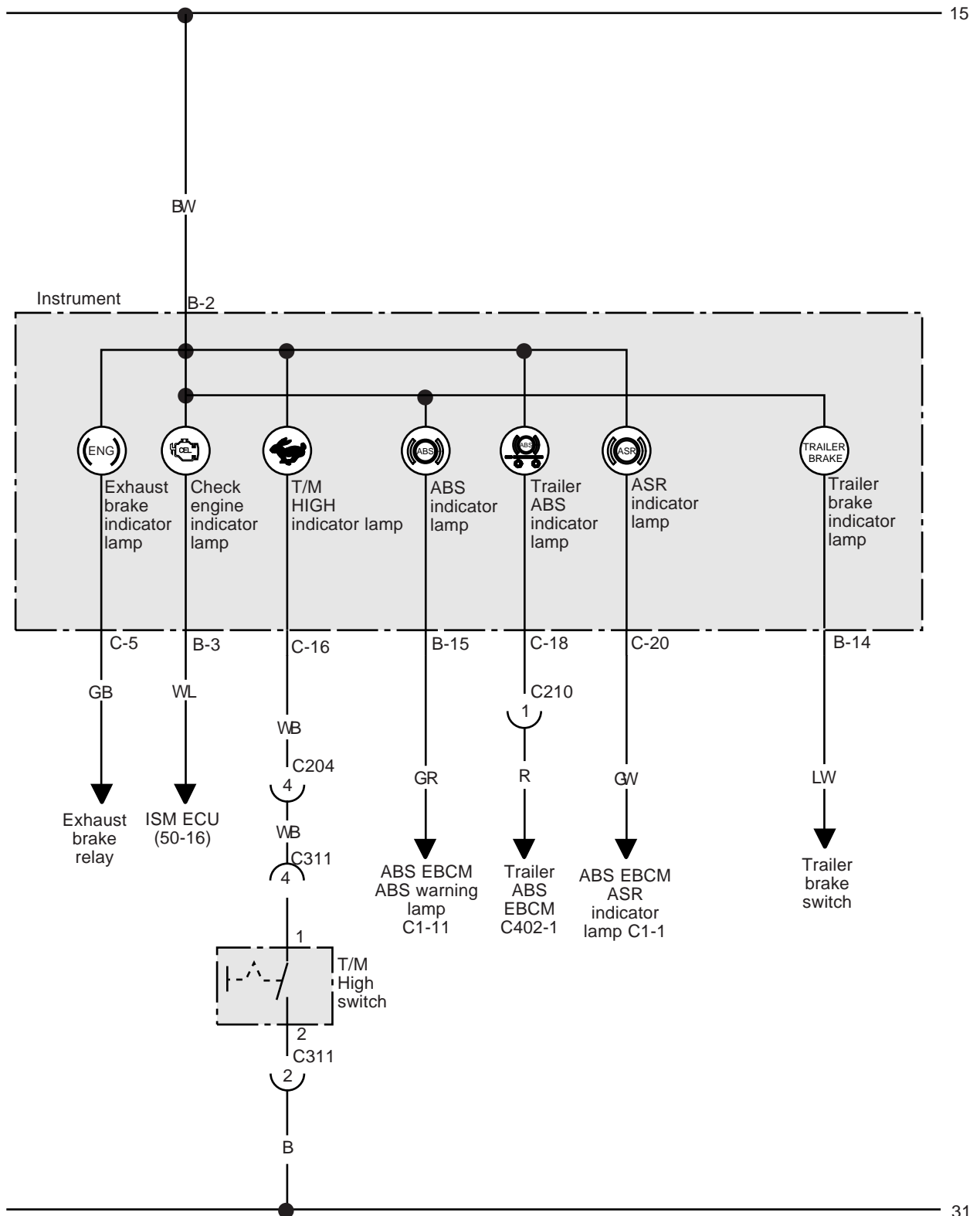

41-5-1. SWITCH AND WARNING LAMP CIRCUIT DIAGRAM(FOR AOH)

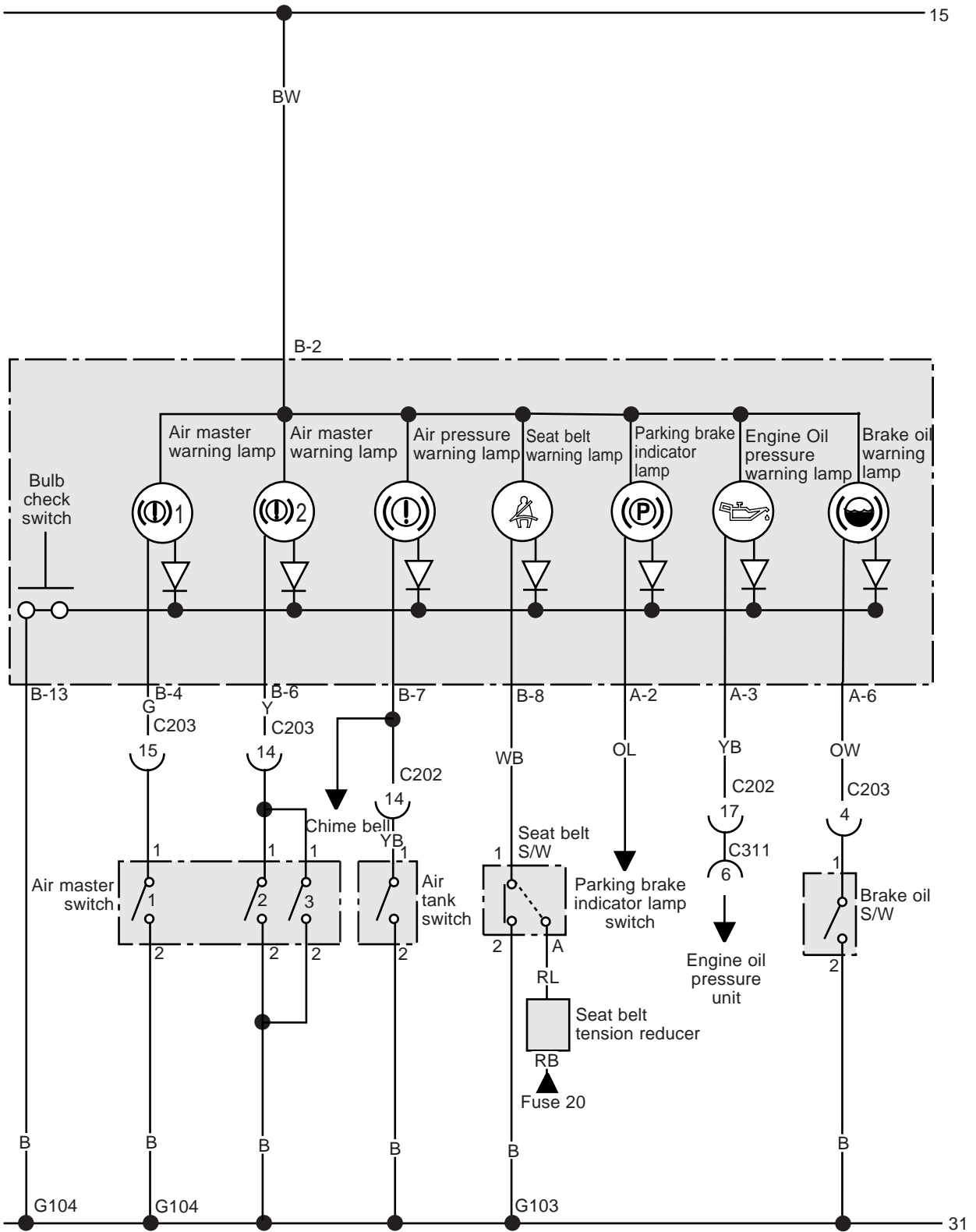

41-5-2. SWITCH AND WARNING LAMP CIRCUIT DIAGRAM(FOR FAB)

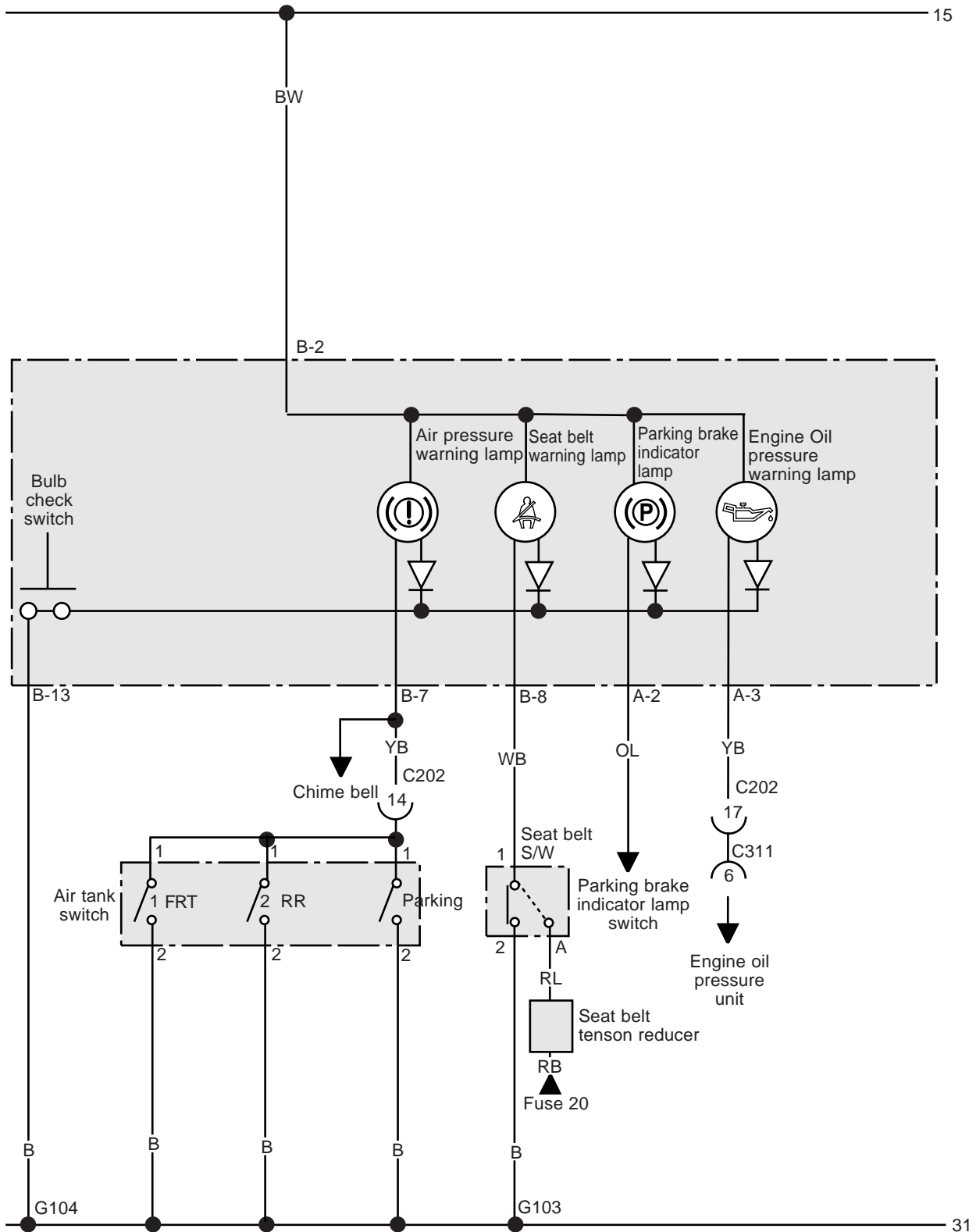

41-5-3. SWITCH AND WARNING LAMP CIRCUIT DIAGRAM

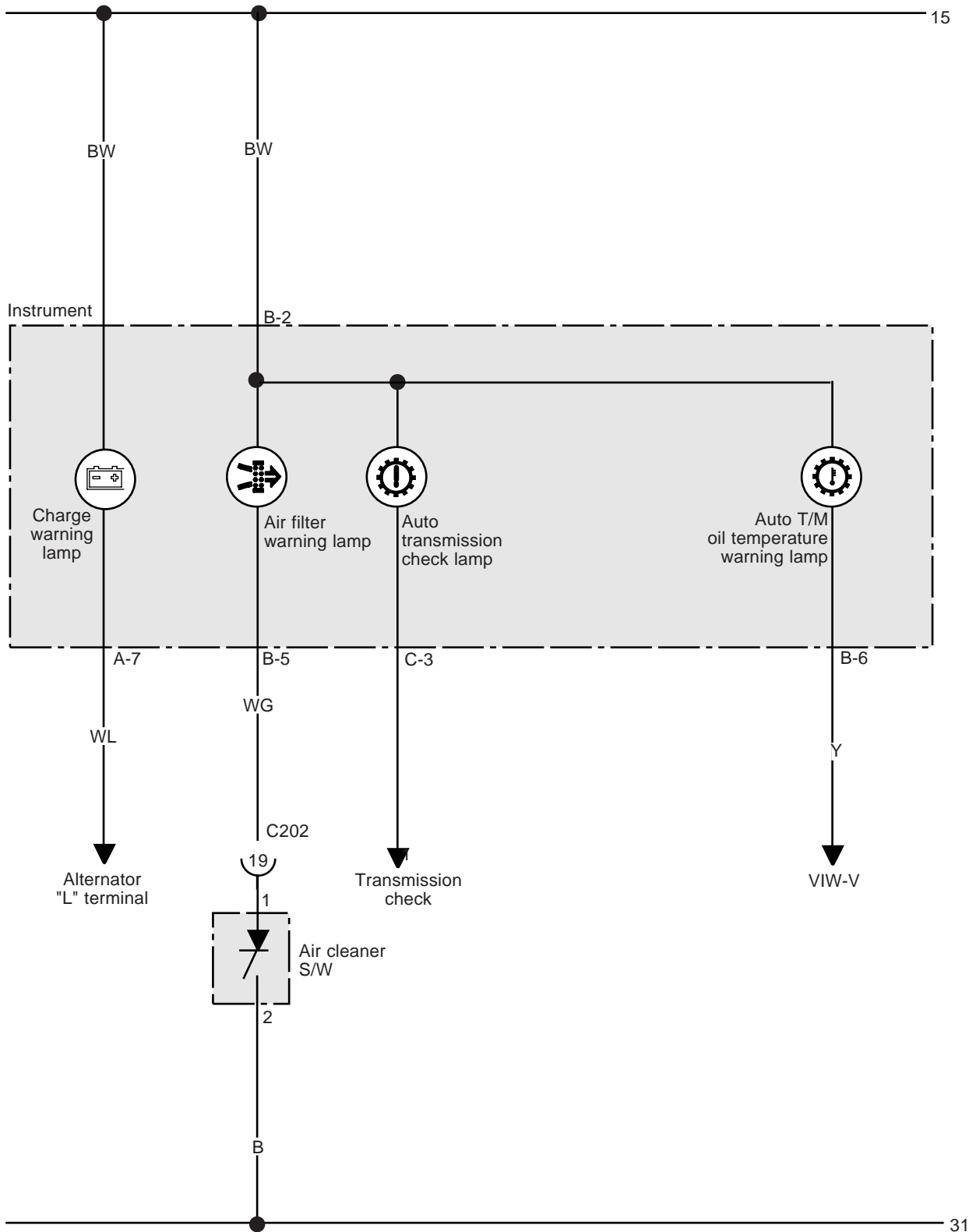

BLANK

42. HANDS FREE KIT CIRCUIT DIAGRAM

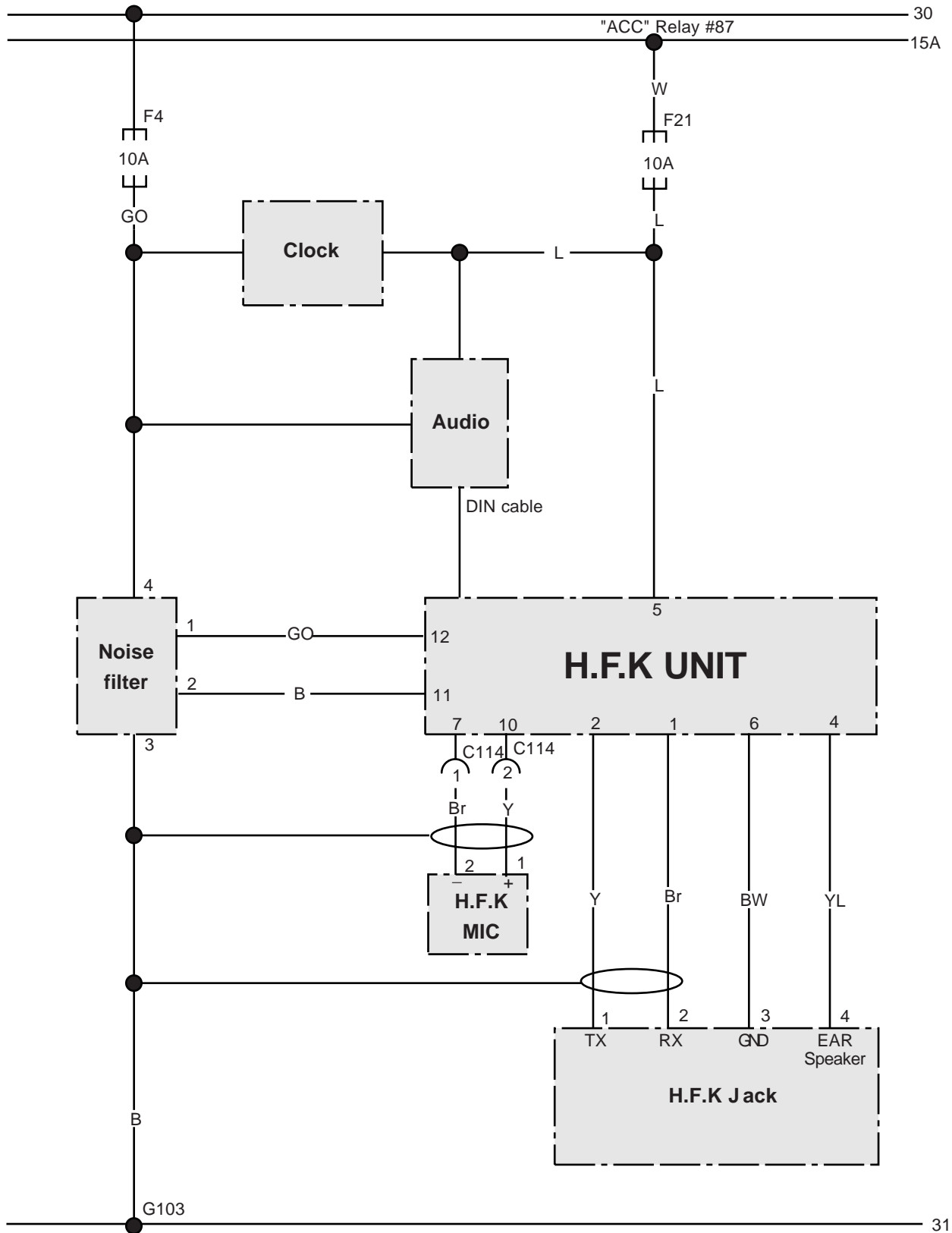

1) CONNECTOR AND PIN NUMBER

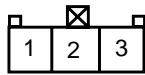

C114, 3pin

Dash - Root harness
(Based on dash harness)

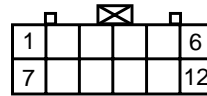

H.F.K unit
(Based on dash harness)



H.F.K jack
(Based on dash harness)

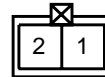

H.F.K MIC
(Based on roof harness)

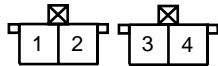

Noise filter
(Based on dash harness)

43. ENGINE SPEED CONTROL SYSTEM(E S C S)

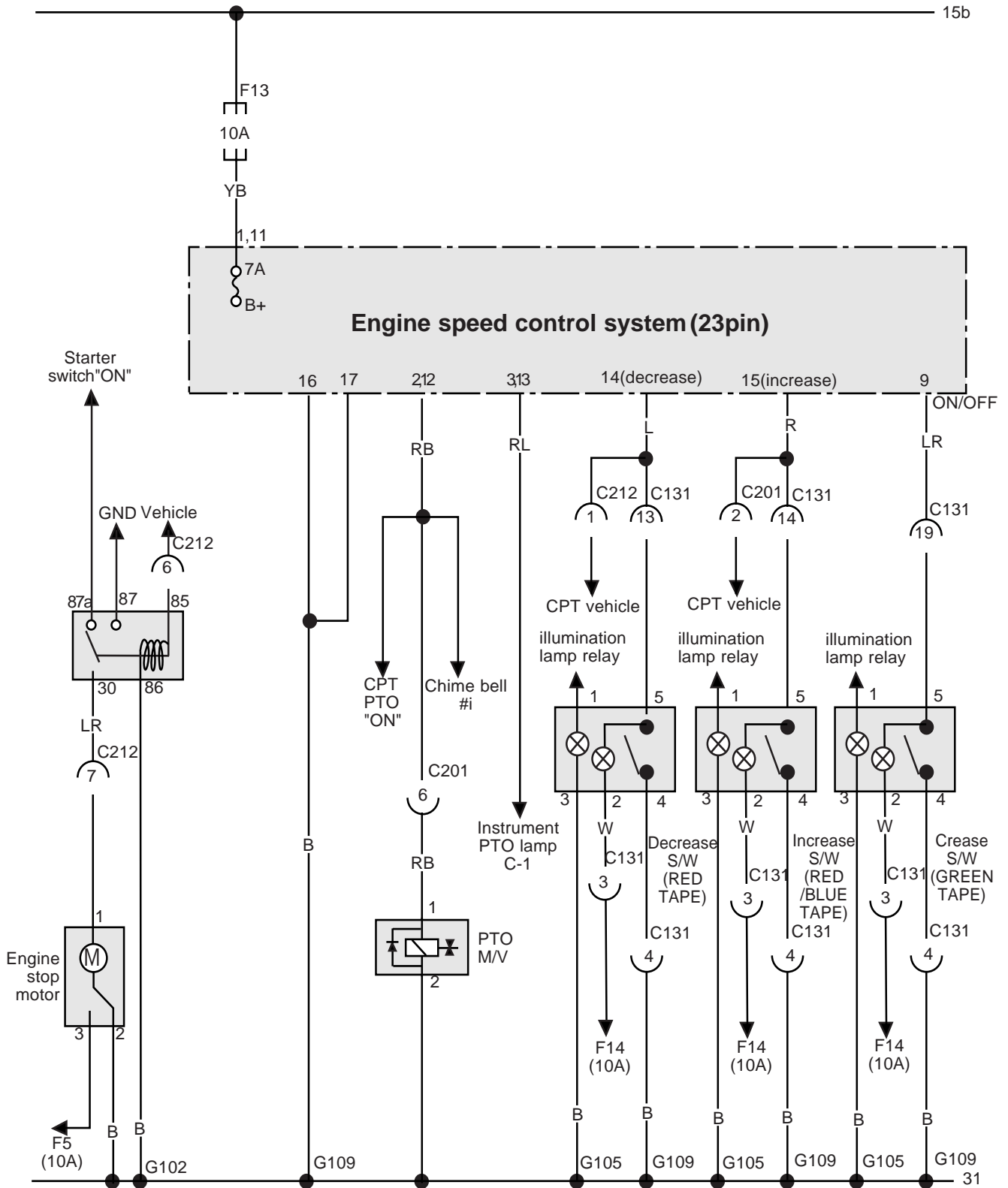

BLANK

43-1. ENGINE SPEED CONTROL SYSTEM (E S C S)

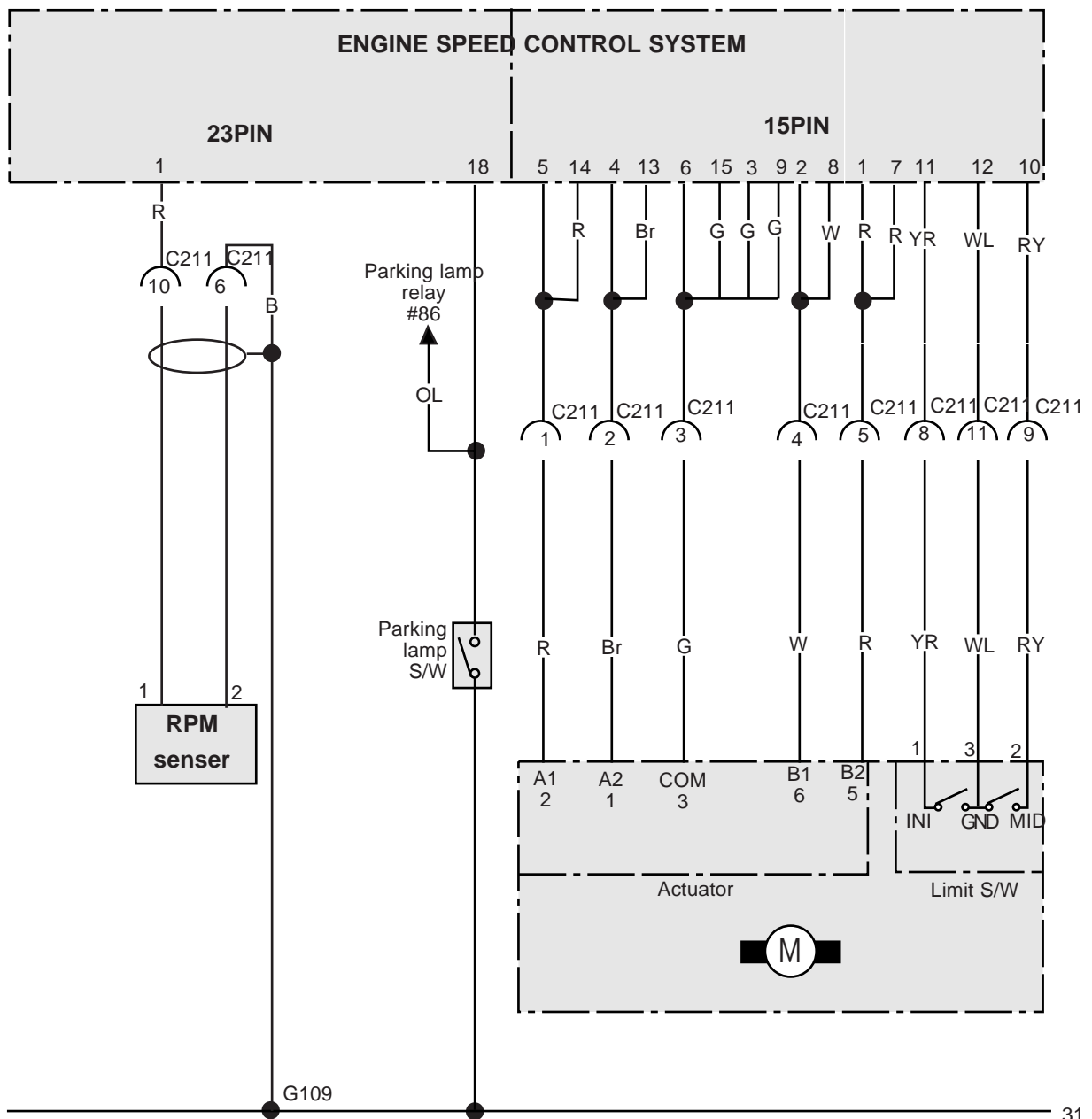

1) CONNECTOR AND PIN NUMBER

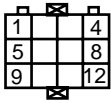

C211

Dash - Frame harness
(Based on dash harness)



C212

Dash - Frame harness
(Based on dash harness)

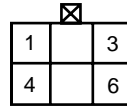

Actuator-motor

(Based on frame harness)

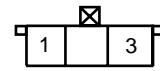

Actuator-limit S/W

(Based on frame harness)

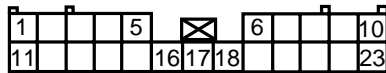

23pin

ESCS ECU connector
(Based on dash harness)

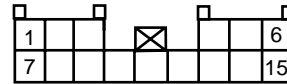

15pin

ESCS ECU harness
(Based on dash harness)



Neutral S/W
(Based on engine harness)

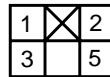

PTO/decrease/increase S/W
(Based on dash harness)

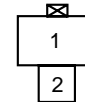

Engine stop S/W

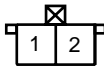

RPM sensor/PTO M/V
(Based on frame harness)

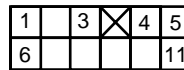

Exhaust combination S/W
(Based on dash harness)

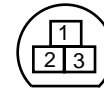

Engine stop motor
(Based on frame harness)

44. OIL COOLER CIRCUIT DIAGRAM (ALLISON AUTO TRANSMISSION)

44-1. AUTO TRANSMISSION OIL COOLER CIRCUIT DIAGRAM.

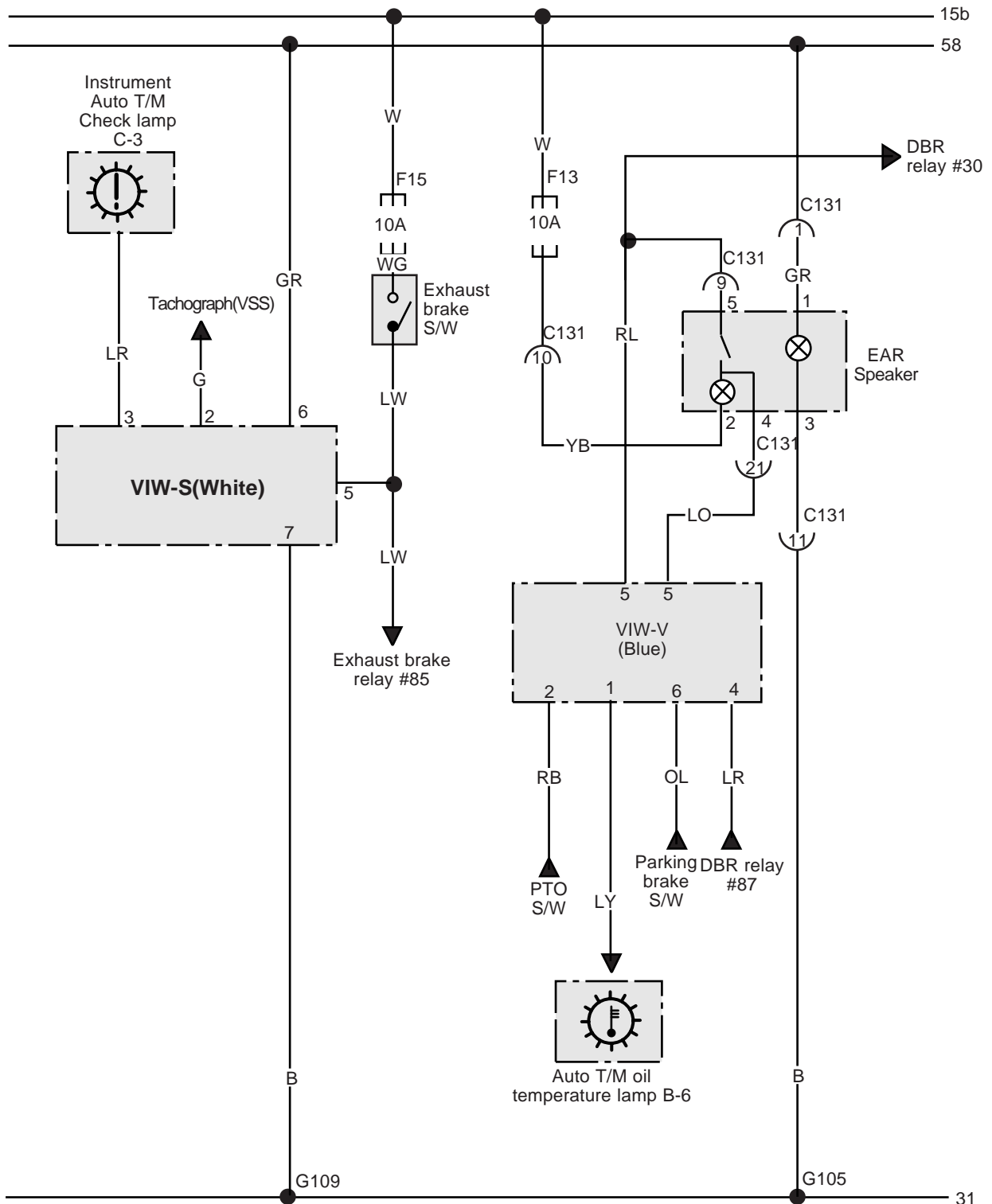

1) CONNECTOR AND PIN NUMBER

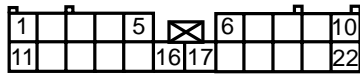

C131, 22pin

Dash - Switch harness
(Based on dash harness)

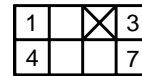

VIW-S

(Based on dash harness)

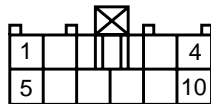

VIW-V

(Based on dash harness)

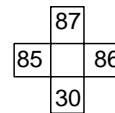

Exhaust brake relay

44-2. AUTO T/M OIL COOLER CIRCUIT DIAGRAM

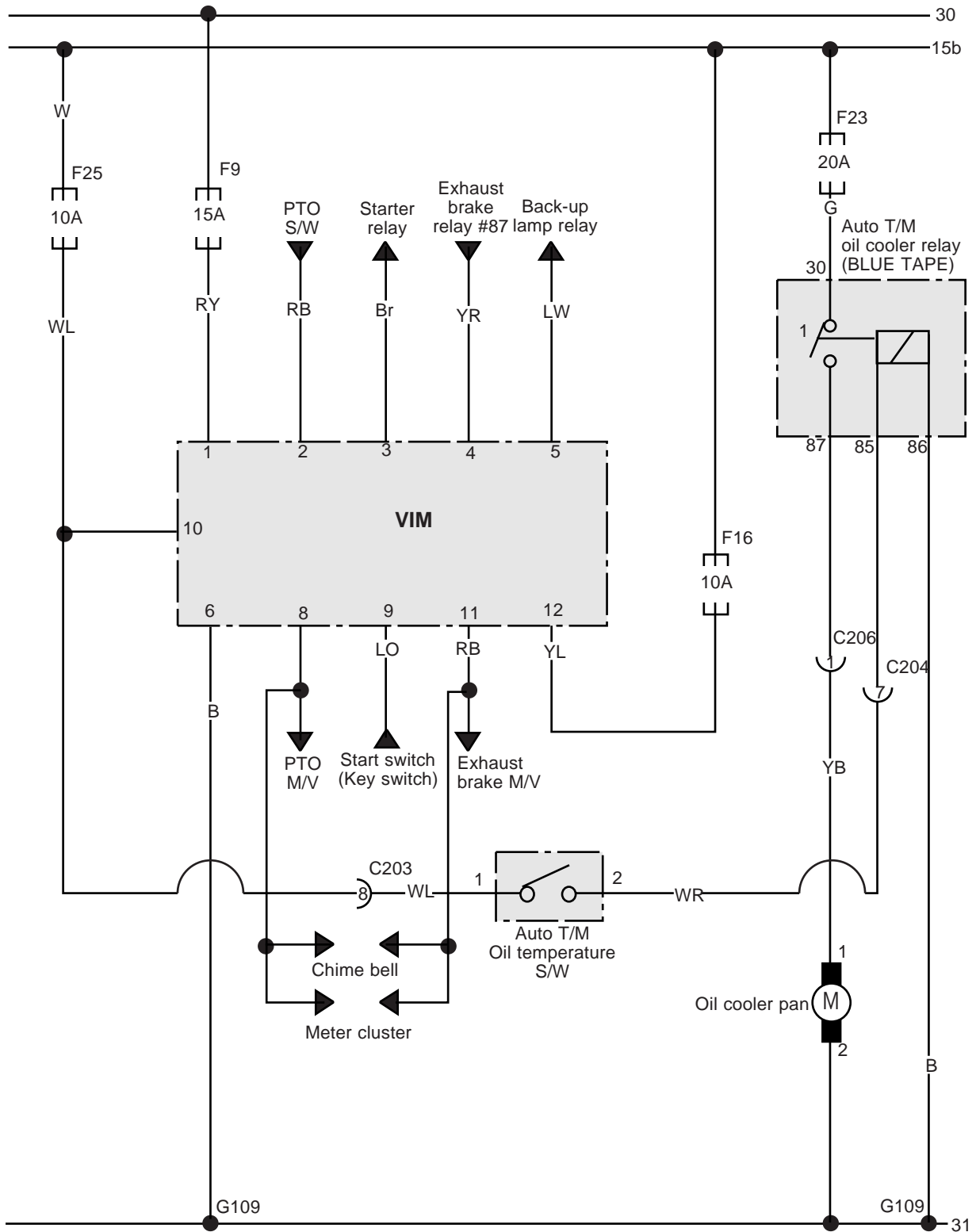

1) CONNECTOR AND PIN NUMBER

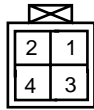

C206, 4pin

(Based on frame harness)

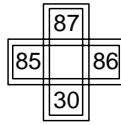

T/M oil cooler relay
(Based on dash harness)

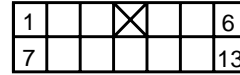

VIM
(Based on dash harness)

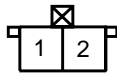

T/M oil temperature S/W
(Based on frame harness)

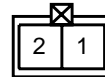

T/M oil cooler
(Based on frame harness)