

Truck 14000 S



AGRALE

www.agrale.com.br

📱📺📷 [agraleSA](#)



AGRALUB



PARTS &
SERVICES



WARRANTY

Truck 14000 S

Generated on 17/07/2022 12:05:18

ENGINE - MWM MAXXFORCE 4.8 / CUMMINS ISB 4.5L	
No. of Cylinders/Displacement	4 - 4748 cm / 4 - 4460cm
Maximum Power	190cv (140 kw) a 2200rpm / 207cv (152 kw) a 2300rpm
Maximum Torque	720 Nm a 1200-1600 rpm / 760 Nm de 1400-1800 rpm
Aspiration	Sobrealimentado com dois estgios de turbo / Sobrealimentado com turbo aftercooler
ELECTRICAL SYSTEM	
Tension Battery Alternator	24 V
TRANSMISSION - EATON FS 5406 A	
Clutch External Diameter	Orgnica - Monodisco a seco c/ acionamento hidraulico assistido a ar
External Diameter	365 mm
No. of Gears	6 a frente/1 a ré
AXLE	
Front axle	SIFCO 6.0
Front	Viga l em ao forjado
Rear axle	MERITOR 19-235
Standard ratio	4,56 / 6,36 :1
THEORETICAL PERFORMANCE	
Maximum Speed	106 km/h / 105 Km/h (NS) 99 Km/h / 98 Km/h (OPC)
Gradeability (GVW)	60,9% / 67,2% (NS) 67,1% / 74,4% (OPC)
TIRES	
Dimensions	275/80R22,5 (NS) 1000x20 com câmara (OPC) 275/80R22,5 (p/ caçamba) (OPC)
WHEELS	
Dimensions	7,50" x 22,5
CHASSI	
Type	Escada em LNE 38 - Perfil "C" Parafusado
Front Suspension	Molas parabólicas progressivas e Barra estabilizadora
Rear Suspension	Molas semi-elípticas progressivas de duplo estágio e Barra estabilizadora
Shock Absorbers	Telescópicos de dupla ação

BRAKES	
Service Brake	Tambor/ "S CAM" Pneumático Assistido Eletronicamente (ABS/EBD/ATC) com regulagem automática
Engine Brake	Eletro-pneumático/Tube de escape
Parking Brakes	Spring brake 30
STEERING	
Type	Hidráulica
Turning Circle	14,4 m / 16,5 m
SUPPLY CAPACITY	
Fuel Tank (Diesel S50)	210 L(opc. 300, exceto para EE 3.560mm)
Urea Tank (Arla 32)	35 L
WEIGHTS AND CAPACITIES	
Curb weight	5.140/5.290kg
GVW - Gross Vehicle Weight	14.000 kg
GVW with 3rd axle (installed by others)	NA
Payload	8.860/8.710Kg
MTC - Maximum Traction Capacity	27.200 kg
Maximum Load of Front Axle	5.000 Kg
Maximum Load of Rear Axle	9.000 Kg
FEATURES	
24V/12V Converter , Air deflectors (front columns), Automatic Brake Adjuster, Clutch servo pneumatic cylinder, Cruise Control, Digital tacograph, Engine Brake, Fog Light, Forced ventilation and defroster , Headrest , Kit Hydraulic Tilt Cab, On-Board Computer in the cluster, Rear Stabilizer Bar, Urea tank cap with key	
OPTIONALS	
Blind spot mirror (front and right), Calibration and Cleaning Kit, Catch-hands ceiling, Catch-hands doors, DRL - Daytime Running Light, Electric Window, Fuel Tank - 300 lt, Heating System , Kit - Sleeper berth, Metallic Colors (Silver, Gray, Brown), Net storage (rear panel), Port-soap, Rear Axle with Simple Reduction, Solid Colors (Yellow, Green, Blue), Storage box (dashboard), Wide angle (two sides)	

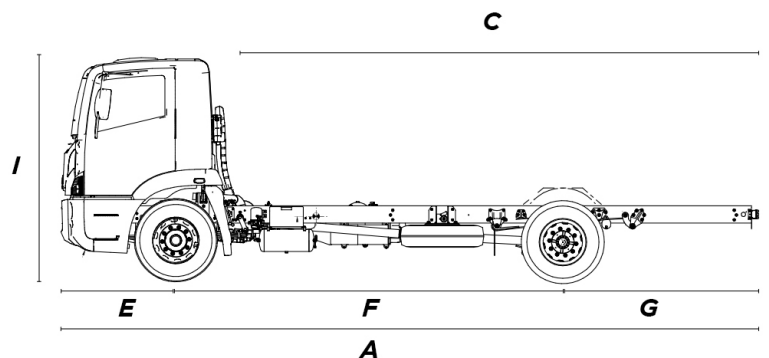

A	Comp. Total	8680 mm
B	Altura Cabine	2800 mm
C	Comprimento livre aplicações	6320 mm
D	Altura Mínima Solo	245 mm
E	Balanço Dianteiro	1430 mm
F	Entre Eixos	4800 mm
G	Balanço Traseiro	2365 mm
H	Largura Espelho à Espelho	3000 mm
I	Altura Total	2800 mm



This literature is for the product information and i products with characteristics or different optional the Commercial Proposed celebrated by the legal