

HD9

chassis 6x6

66.38 / 66.42 / 66.44 / 66.48 / 66.54

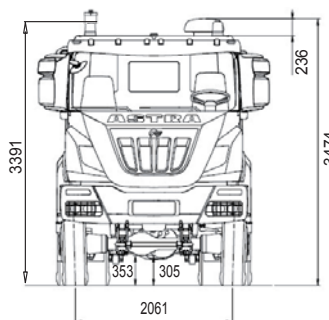
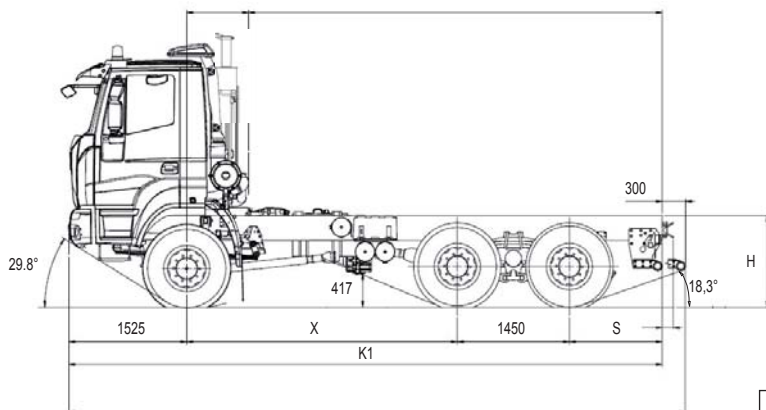

ON REQUEST	
■	RHD VERSION (opt. code 962)
■	LONG CAB VERSION (opt. code 200; opt. code 272)
wheelbase ≥ 3800 mm	



DIMENSIONS (mm) short cab (Tyres 13R22,5 156/150G)

X	K1	M max (*)	S	H		TURNING DIAMETER (wall to wall)
				unloaded	loaded	
3500	7675	5350	1200	1252	1189	17400
3800	7975	5650	1200			18300
4100	8275	5950	1200/1500/1900			19300
4500	8675	6350	1200/1900/2500			20600

(*) M max.: indicative value to be confirmed by bodybuilder.



WEIGHT (kg)

X	Distribution net weight (*)			Max. technical weight			
	1st axle	2nd+3rd axle	Net weight	1st axle	2nd+3rd axle	Gross Vehicle weight	Gross Combination weight
3500	5365	4938	10303	8000	32000	40000 (2)	104000
3800	5409	4929	10338	8500(1)			
4100	5447	4919	10366	9000(2)			
4500	5503	4921	10424	10000(3)			

(*) Weight including oil, fuel, spare wheel, driver Kg.75

(1) With tyres 1st axle 385/65R22,5160J or 365/85R20166G. Other tyres available, subject to the Astra technical office approval.

(2) HD9 66.48 and HD9 66.54 only at max speed 50 km/h. Michelin/Pirelli tyres. Higher speeds are allowed with load reductions subject to the Astra Technical office approval.

(3) 10,000 kg optional: see description on the following pages 10 t.



ENGINES

CURSOR 13 turbo intercooler **euro 3** diesel injection/cycle with electronic unit injection pumps. Single block head, four valves per cylinder, light alloy pistons. Total displacement: 12.882 cm³. Bore for stroke: 135 x 150 mm. 6 in-line cylinders. Water cooling. Viscostatic cooling fan. Dry air filter with safety cartridge. Vertical muffler

	66.38	66.42	66.44	66.48	66.54*
Model	IVECO F3B	IVECO F3B	IVECO F3B	IVECO F3B	IVECO F3B
Max. power (EEC)	280 kW (380 HP)	309 kW (420 HP)	324 kW (440 HP)	353 kW (480 HP)	397 kW (540 HP)
Corresponding rpm	1.900		1.900		
Max. torque (EEC)	1.800 Nm (183 kgm)	1.900 Nm (194 kgm)	2.100 Nm (214 kgm)	2.200 Nm (224 kgm)	2.350 Nm (240 kgm)
Corresponding rpm	1.000-1.440				1.000-1.690
Turbine	WG Waste Gate		VGT variable geometry		

*Requires additional engine radiator, for extremely hot climate (>42°C).



GEARBOX

Manual ZF Ecosplit 4 technology gearbox with servoshift, 16 synchronised forward speeds + 2 reverse:

ZF16S2220TO: HD9 66.38/HD9 66.42 / HD9 66.44

ZF16S2520TO: HD9 66.48/HD9 66.54

On request:

ZF16S2320TD: HD9 66.38/HD9 66.42/ HD9 66.44/ HD9 66.48

ZF ASTRONIC 16AS2601OD: HD9 66.44/ HD9 66.48/ HD9 66.54

ALLISON HD4700: HD9 66.44/ HD9 66.48/ HD9 66.54 (wheelbase>4100mm)

		Speed [kph] calculated at maximum power rpm																			
		Gears																			
		1	2	3	4	5	6	7	8	9	10	11	12	13	14	15	16	RM	RM		
ZF 16S2220TO - ZF 16S2520TO	Gear ratios	16.41	13.80	11.28	9.49	7.76	6.53	5.43	4.57	3.59	3.02	2.47	2.08	1.70	1.43	1.19	1.00	15.36	12.92		
	Rear axle ratio with transfer 1:1.0	3.793	7.5	8.9	10.9	13.0	15.8	18.9	22.5	27.0	34.1	40.7	49.5	59.2	72.0*	85.9*	103*	122.7*	8.0	9.5	
		4.229	6.7	8.0	9.7	11.7	14.2	16.9	20.2	24.2	30.6	36.5	44.4	53.1	64.6	77.0*	92.4*	110.0*	7.2	8.6	
		5.009	5.7	6.8	8.2	9.8	11.9	14.3	17.1	20.4	25.8	30.8	37.5	44.8	54.6	65.0	78.0*	92.9*	6.0	7.2	
		5.558	5.1	6.1	7.4	8.9	10.8	12.9	15.4	18.4	23.3	27.8	33.8	40.4	49.2	58.6	70.3*	83.7*	5.4	6.5	
		6.095	4.6	5.6	6.8	8.1	9.8	11.7	14.0	16.8	21.2	25.3	30.8	36.8	44.8	53.4	64.1	76.3*	5.0	5.9	
		6.588	4.3	5.1	6.3	7.5	9.1	10.9	13.0	15.5	19.6	23.4	28.5	34.1	41.5	49.4	59.3	70.6*	4.6	5.5	
	Gear ratios	16.41	13.80	11.28	9.49	7.76	6.53	5.43	4.57	3.59	3.02	2.47	2.08	1.70	1.43	1.19	1.00	15.36	12.92		
	Rear axle ratio with transfer 1:1.6	3.793	4.7	5.6	6.8	8.1	9.9	11.8	14.1	16.9	21.3	25.5	31.0	37.0	45.0	53.7	64.4	76.7	5.0	6.0	
		4.229	4.2	5.0	6.1	7.3	8.8	10.6	12.6	15.1	19.1	22.8	27.8	33.2	40.4	48.1	57.8	6	8.8	5.5	3.4
		5.009	3.5	4.2	5.1	6.1	7.5	8.9	10.7	12.8	16.1	19.3	23.4	28.0	34.1	40.6	48.8	58.0	3.8	4.5	
		5.558	3.2	3.8	4.6	5.5	6.7	8.0	9.6	11.5	14.6	17.4	21.1	25.3	30.7	36.6	43.9	52.3	3.4	4.1	
6.095		2.9	3.5	4.2	5.1	6.1	7.3	8.8	10.5	13.3	15.8	19.3	23.0	28.0	33.4	40.1	47.7	3.1	3.7		
6.588		2.7	3.2	3.9	4.7	5.7	6.8	8.1	9.7	12.3	14.7	17.8	21.3	25.9	30.9	37.1	44.1	2.9	3.4		

(*) Max speed 90 km/h. Other speeds available, subject to the Astra technical office approval.



P.T.O.

On request:

Gearbox	ZF16S2220TO ZF16S2520TO	Max. torque Nm.	Application
P.T.O.	Ratio		
ZF NH/1b	0,91/1,09:1	1000	For tipping unit pumps, pumps for cranes, ecc..
ZF NH/1c	0,91/1,09:1	1000	For tipping unit pumps, unit pumps for concrete, pumps for cranes, ecc..
ZF NH/4c	1,17/1,40:1	430	For tipping unit pumps, ecc..
ZFN221/10bpl+N353/1c	1,75/2,09:1+0,91/1,09:1	560+600	double PTO for concrete pumps

ZF NMV 221 Power take-off (ratio 1,55:1) max available torque 1300 Nm for concrete pumps (only for 380, 420 and 440 HP and wheelbase >3800mm).

ZF NMV 221 Power take-off (ratio 0,98:1) max available torque 2000 Nm for concrete pumps (only for 380, 420 and 440 HP and wheelbase >3800mm).

Power take off at flywheel (ratio 1,29:1) max available torque 900 Nm for concrete mixers (only for 380, 420 and 440 HP and wheelbase >3800mm).

PTO Chelsea for Allison gearbox HD4700.



CLUTCH

Single dry plate, diameter 17".

Pull type engagement with diaphragm spring.

Hydro-pneumatic power steering engagement control, with driven disc wear recovery slave cylinder.

On request: Ceramic clutch 17"



TRANSFER

Mechanical with two ratios. It consists of a series of helical spur gears, mounted on three propeller shafts, engaged with each other.

Differential can be locked by pneumatic control.

Transmission ratio: 1:1 - 1:1,6

Front/rear torque distribution ratio: 1:4,0



AXLES

FRONT:

Steering cast iron type; with double reduction, central with bevel pinion-crown, lateral by means of epicyclical assembly in wheel hubs.

On request:

Front axle simplex or duplex wedge type Kessler.

Kessler front axle:

Version	Weight on 1 st axle	Available axle ratio	Pneus
HD9 K	8 t @90 Km/h	5,01; 5,384; 5,866; 6,28	13 R22.5; 12.00 R20; 14.00 R20

REAR:

Two drive axles in tandem with double reduction, central by bevelled pair and final by epicyclical group in wheel hubs.

The intermediate axle is fitted with distributor that distributes torque between the two axles Lockable differential with pneumatic control from driver seat. The tandem is anchored to the chassis by silent block mounted torque arms.

On request:

Rear-axle ratio 1:3.793

Rear-axle ratio 1:4.229

Rear-axle ratio 1:5.009

Rear axle ratio 1:5.558

Rear-axle ratio 1:6.095

Rear-axle ratio 1:6.588

10t FRONT AXLE G.V.W. 10t

On request: Front axle simplex or duplex wedge type Kessler and Gross Weight 10,000 Kg. Parabolic springs 5 leaves 24x90 mm.

Hydraulic power steering ZF 8099 with variable ratio 1:22.2/1:26.2. Tyres combination subject to approval of Astra Technical Office. Axle ratio 1:6.33. Maximum speed 70 Km/h.



SUSPENSIONS

FRONT

Parabolic leaf springs with bushings, 4 leaves 24x90 mm, with shock absorbers and standard stabiliser.

On request:

Reinforced conventional springs. 10 leaves 15x90 mm.

Reinforced parabolic springs, n° 5 leaves 24x90 mm.

REAR

Parabolic springs, swivelling on central pin: 4 leaves 40x100 mm, supplemented by torque bars and stiffening brackets.

On request:

Stabiliser bar on 2nd axle.

Stabiliser bar on 3rd axle.

Extra-reinforced conventional springs, 10 leaves 25x100 mm.



TYRES

FRONT: 13R22,5 156/150 G Single tubeless

REAR: 13R22,5 156/150 G Twin tubeless

Spare wheel on the chassis.

Other Possible combinations:

TYRES	ASSEMBLY	
	FRONT	REAR
13 R 22,5 156/150G		
12 00 R 20 156/150G	S	D
315/80 R 22,5 156/150G		
365/85 R 20 164G	S	
13 R 22,5 156/150G		
12 00 R 20 156/150G		D
365/80 R 20 160K		
385/65 R 22,5 158K	S	
315/80 R 22,5 156/150G		D
395/85 R 20 168G	S	
525/65 R 20,5 173F		S
16 00 R 20 173G	S	S
16 00 R 20 163G	S	
24 R 20,5 176F		S

S single

D double

Other tyres available, subject to the Astra technical office approval.



PNEUMATIC SYSTEM

Two-cylinder 630 cc compressor , APU (Air Processing Unit) that includes: regulation valve set at 10.3 bar, drier, 4-way safety valve, pressure reduction valve for parking circuit and services. 3 air tanks, capacity 30 litres + 2 with 20 litres. ABS system and EBL (Electronic Brake Limiter)



CHASSIS

Special steel with high elasticity limit, two flat and parallel side members width 820 mm., C section 320x90x10mm, cross members riveted to the frame.

Steel front bumpers with headlamp protection grids, front manoeuvring hook, rear underrun bar, steel fuel tank capacity 300 litres.

On request:

Extra long underrun bar for concrete mixer.

Front bumper climbing step.

Rapid attachment for compressed air for tyres'inflation.

Rear underrun bar in set back position.

Rear manoeuvring hook.

Rear automatic towing hook.

Rubber mudguards on 2nd and 3rd axle.

Side windlass for spare wheel



STEERING

Hydraulic power steering ZF 8098 with variable ratio 1:22.2/1:26.2.

Steering linkage with self lubricating floating joints.

Height and inclination mechanical adjustable steering wheel.





ELECTRICAL SYSTEM

Voltage: 24 V
 Alternator generator 90 A - 28 V (2520 W).
 Accumulators: 2 in series, 160 Ah.
 Starter motor 24 V 5,5 kW.
 Mechanically controlled electrical circuit breaker.
 1 electrical joint 7-pole(ISO 7638) for trailer ABS(if applicable).
 1 electrical joints 15-pole(ISO 12089-4091) for trailer lighting (if applicable).
 Electrical provision for bodybuilders.
 Provision for diagnostics.
 Provision for radio/cb (without speakers)
 Glow plug for cold start.

On request:

170 Ah accumulators;
 160 Ah tropicalised accumulators;
 170 Ah tropicalised accumulators;
 Reverse alarm;



CAB

White cab built in galvanized pressed steel with hydraulic tilting up to 60°. Cab suspension with 4 helicoidal springs with coaxial shock absorbers and integrated dampers, anti-roll bar and end-of-stroke pads. Tinted electric door windows. Mechanical rear view mirrors, wide angle mirrors and front view mirror. Internal panels completely washable and fireproof. Compressed air quick coupling for cab cleaning. 4-speed ventilation and heating system with air recirculation system. Air suspended 3-way adjustable driver seat with seat belts. Mechanical passenger seat with seat belts.

On request:

Air conditioning with anti-pollen filter
 Cab rear window.
 Car radio RDS, CD.
 Car radio RDS, CD, MP3 Bluetooth technology.
 External sun visor.
 Extra colour cab: to be specified in the order.
 Heated and electric powered rear view mirrors.
 Long cab for wheelbase >3800mm with interior equipment (seats and beds) on request.
 Remote controlled and centralized closing of doors.
 Roof hatch.
 Rotating lights on top of the cab.
 White engine hood with central mask in IC575 colour



SERVICE DATA(I)

Engine oil sump and filters	28
Gearbox oil: ZF 16S2220TO/ZF 16S2520TO	13
Power steering oil	8,5
Cab tipping oil	1
Clutch circuit oil	0,5
Integral PTO oil	3
Intermediate axle with final red. oil	27
Rear axle with final red. oil	16
Cooling system water	33
Diesel	300



INSTRUMENTATION

Dashboard and ergonomic instrument board contain the function buttons and the identification commands.

Indicator lights: engine oil low pressure, alternator charging low, main beam lights, side lights, engine warm-up, rear fog light, hazard lights, tractor turn indicators, trailer turn indicators (if applicable), rotating lights, cab lifted, axles differential locked, differential lock, front brakes air pressure low, rear brakes air pressure low, trailer brakes air pressure low (if applicable), parking brake engaged, splitter (reduction on), slow speeds (1-4/9-12), power take-off on (if applicable) air filters clogged, power steering oil level low, rear view mirrors heated (if applicable), ABS, trailer ABS (if applicable), main steering circuit failure, steering auxiliary circuit failure.

ASTRA Veicoli Industriali

Via Caorsana, 79
 29122 Piacenza (Italy)
 Tel. ++39-523/5431
 Fax ++39-523/59.17.73
 www.astraspa.com

DEALER

Characteristics and equipment are subject to changes without prior notice.



Technical data and general specifications - validity to be checked according to each individual country.